









The Art of Falconry

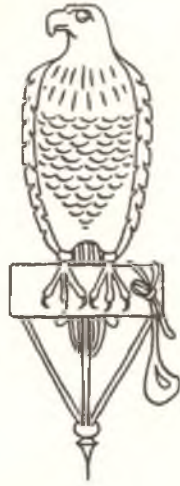

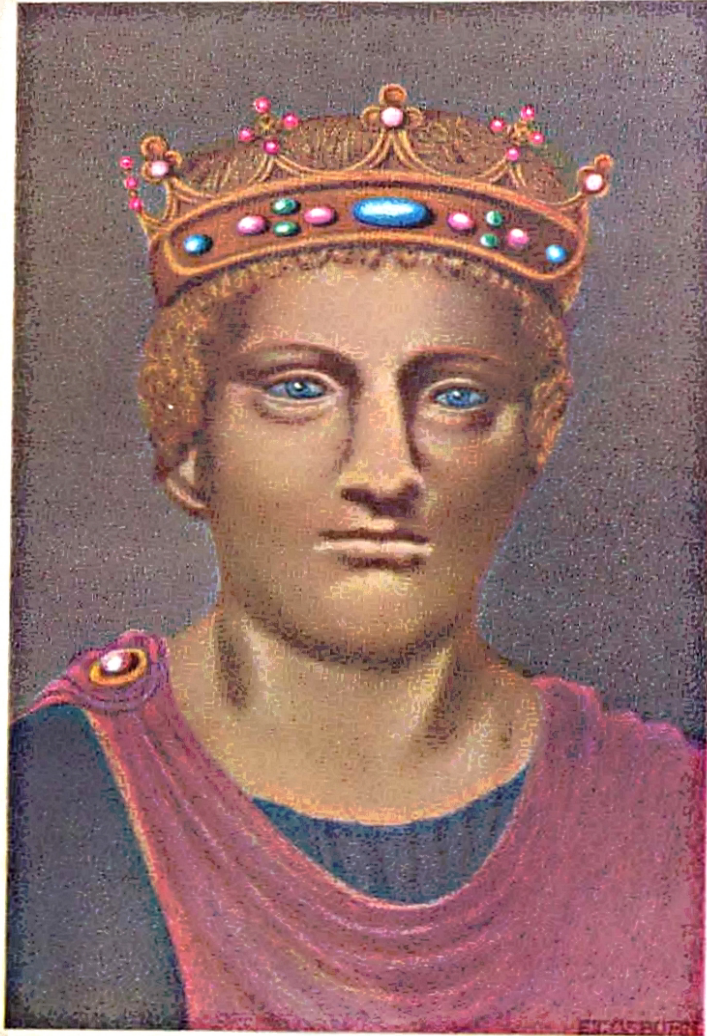

Emperor Frederick II of Hohenstaufen

Portrait prepared from the cast of a bust that stood formerly
over the Capua Gateway, by O. T. Osborn



THE ART OF
alconry

being the
*DE ARTE VENANDI
CUM AVIBUS*

of
FREDERICK II
of Hohenstaufen

Translated and Edited by
CASEY A. WOOD
&
F. MARJORIE FYFE

CHARLES T. BRANFORD COMPANY

Boston 16, Massachusetts

London: Geoffrey Cumberlege
Oxford University Press

*Copyright 1943
Stanford University Press*

Reprinted 1955

*Charles T. Branford Company, Boston, Mass.
Geoffrey Cumberlege, Oxford University Press, London*

*By Arrangement with
Stanford University Press*

To
Eliza Graham Wilson



Itaque palam est, quod ars venandi cum avibus & ars est,
& ceteris venationibus nobilior, & dignior, & ideo prior.

De Arte Venandi cum Avibus, Book I, Cap. I, 1248

I have bought me a hawk and a hood, and bells and all,
and lack nothing but a book to keep it by.

BEN JONSON, *Every Man in His Humour*, 1598

Et tout ainsi qu'on ne scauroit lire sans congoistre les
lettres; de mesme on ne peut estre Fauconnier sans cog-
noistre les Oyseaux, ce qui est le principe de cest art.

CHARLES D'ARCUSSIA, *La Fauconnerie*, 1589

CASEY A. WOOD

1856-1942

All that thy seasons bring, O Nature,
is fruit for me!

All things come from thee, subsist in thee,
go back to thee.

MARCUS AURELIUS,
Book IV, sec. 23

Foreword

WHEN I learned that Dr. Casey A. Wood was making a study of the eyes of birds, I realized that I had met up with an unusual man. When Dr. Wood noted that birds could see things that he could not see, he wanted to know why. Wanting to know why was the mainspring of much of his life. Skilled and successful as a practitioner of medicine, he early in life began to show those side interests which are often more determining than anything else in developing a man's career. Not only was he interested in research of a fundamental sort, but he particularly enjoyed looking back into the past and discovering through literature just what had been known in the years gone by and how it became known. His interest in good books and in old and classical treatises developed him into a collector of unusual acumen and of real distinction.

It was a very natural thing in the later years of his life for Dr. Wood to make a study of the art of falconry, since the falcon depends on eyesight far more than the ordinary animal or bird. I cannot help thinking of the intense pleasure he must have had in turning the pages of old books and gathering together the material for this present volume. The falcon as a hunter goes far back into human history. It was just the sort of topic that Casey Wood relished.

Those who love birds, enjoy hunting, or are interested in the relation of man to domesticated animals and birds will appreciate this book, Dr. Wood's last production in a long, useful, and active career in medicine, research, and literature.

It is sad that Dr. Wood's death, on January 26, 1942, prevented him from having the rare pleasure of holding in his hand this book of his own creation. No one delighted more than he in these studies of birds.

RAY LYMAN WILBUR

STANFORD UNIVERSITY, CALIFORNIA



Casey A. Wood



TABLE OF CONTENTS

	PAGE
FOREWORD, by <i>Ray Lyman Wilbur</i> —with portrait of CASEY A. WOOD . . . <i>preceding</i>	vii
TRANSLATORS' INTRODUCTION	xxxv
MANUSCRIPTS AND EDITIONS OF THE <i>DE ARTE VENANDI CUM AVIBUS</i>	lvii
THE CASTLES AND HUNTING LODGES OF EMPEROR FREDERICK II, <i>by Cresswell Shearer</i>	xcv
THE ART OF FALCONRY, by <i>Emperor Frederick II of Hohenstaufen</i>	3
GENERAL PROLOGUE TO THE <i>De Arte Venandi cum Avibus</i>	3
BOOK I. THE STRUCTURE AND HABITS OF BIRDS	5
Chapter I. Falconry Is an Art More Noble Than Other Forms of Hunting	5
Chapter II. Of the Division of Birds into Waterfowl, Land Birds, and Neutral Birds	7
Chapter III. Of the Division of Birds into Raptorial and Nonrap- torial Species	9
Chapter IV. Of Waterfowl: When and How They Seek Their Food	15
Chapter V. Of the Exodus of Waterfowl to Their Feeding Grounds	16
Chapter VI. Of the Order in Which Birds Depart for Their Feeding Grounds	17
Chapter VII. Of the Return of Aquatic Birds to Their Water or Swamp Refuges	18
Chapter VIII. Of the Positions Assumed by Birds When Asleep or Awake on or in the Water	18
Chapter IX. How Land Birds Seek Their Food and Why Owls Hunt Their Prey at Night	19
Chapter X. Of the Flight of Land Birds to Their Feeding Grounds, Their Return, and Their General Condition	21

	PAGE
Chapter XI. Of Neutral Birds: How and When They Obtain Their Food	22
Chapter XII. Of Various Foods Consumed by Neutral Birds . . .	22
Chapter XIII. Of the Excursions of Certain Neutral Birds	27
Chapter XIV. Of the Visits of Neutral Birds to Their Feeding Grounds and Their Order of Flight	27
Chapter XV. Of the Return of Neutral Birds to Their Usual Dwelling Places and Their Conduct There	27
Chapter XV-A. Of Rapacious Birds, Their Excursions and Methods of Securing Food, and of Its Kind; Also of Their Return to the Eyrie	28
Chapter XVI. Of the Migration of Birds to Escape the Cold	31
Chapter XVII. Of Which Birds Migrate and at What Season	32
Chapter XVIII. Of the Reasons Why Birds Migrate	32
Chapter XIX. How Birds Prepare for Migration	33
Chapter XX. Of the Seasons and Weather That Favor Migration . .	34
Chapter XXI. Of Early and Late Departure in Bird Migrations, and of Their Flight Formations	39
Chapter XXII. Of Localities Whence Migrations Start, and of Halting Places on the Journey	40
Chapter XXIII. On the Winter Quarters Chosen by Migratory Birds and the Reasons for That Choice	40
Chapter XXIII-A. Of the Return Journey of Birds to Escape from Southern Heat and to Build Their Nests	42
Chapter XXIII-B. Of How the Migration of Birds Compares with Their Return	44
Chapter XXIII-C. Where to Find Migratory and Indigenous Birds . .	44
Chapter XXIII-D. Of the Mating of Birds	45
Chapter XXIII-E. Of Coitus in Birds	49
Chapter XXIII-F. On the Nesting of Birds	49
Chapter XXIII-G. Of the Laying and Incubation of Eggs	52
Chapter XXIII-H. Of the Care and Feeding of Nestlings	53
Chapter XXIII-I. Of the Functions of Avian Organs	56
Chapter XXIV. Of the Eyes of Birds	59
Chapter XXV. Of Avian Ears	60
Chapter XXVI. Of the Nostrils, the Mandibles, and the Shoulders . .	60

Table of Contents

ix

	PAGE
Chapter XXVII. Of the Wings of Birds	64
Chapter XXVIII. Of the Dorsal Region	70
Chapter XXIX. Of the Hips	70
Chapter XXX. Of the Tail	70
Chapter XXXI. Of the Oil Gland (<i>Perunctum</i>)	71
Chapter XXXII. Of the Breast or Thorax	71
Chapter XXXIII. Of the Sides or Flanks of Birds	72
Chapter XXXIV. Of the Toes and Feet	73
Chapter XXXV. Of Avian Claws and Talons	75
Chapter XXXVI. The Internal Organs of the Bird	76
Chapter XXXVII. Of the Trachea and Bronchial Tubes	78
Chapter XXXVIII. Of the Lungs	78
Chapter XXXIX. Of the Diaphragm	78
Chapter XL. Of the Esophagus	78
Chapter XLI. Concerning the Stomach	79
Chapter XLII. Of the Liver	79
Chapter XLIII. Of the Kidneys	79
Chapter XLIV. Of the Testes and the Ovaries	79
Chapter XLV. Of the Plumage of Birds in General	79
Chapter XLVI. Of the Colors of Avian Plumage	80
Chapter XLVII. Of the Contour Feathers	81
Chapter XLVIII. Of the Down	82
Chapter XLIX. Of the Wing Feathers	83
Chapter L. Of the Number of Flight Feathers in the Wing	83
Chapter LI. Of the Arrangement of the Flight Feathers	84
Chapter LII. Of the Number of Tail Feathers	89
Chapter LIII. Of the Position and Form of the Tail Feathers	90
Chapter LIV. Of Modes of Flight in Birds	91
Chapter LV. Of Avian Means of Offense and Defense	95
Chapter LVI. Of the Localities in Which Birds Seek Shelter	97
Chapter LVII. Of the Moults of Birds	97
 BOOK II. OF FALCONS USED IN HUNTING, THEIR FURNITURE, CARE, AND MANNING	105
Author's Preface	105

	PAGE
Chapter I. The Definition of a Bird of Prey, and the Reason for This Designation	107
Chapter II. Why the Female Bird of Prey Is Larger Than the Male	108
Chapter III. Of the Behavior of Birds of Prey During the Nesting Season	110
Chapter IV. Of the Localities Chosen by Raptores for Their Eyries	111
Chapter V. Of Hawks (<i>Accipitres</i>)	112
Chapter VI. Of the Ovulation of Birds of Prey	112
Chapter VII. Of the Brooding Season	117
Chapter VIII. Of the Small Feathers, Down, and Flight Feathers of Birds of Prey	117
Chapter IX. Of the Feeding of Raptorial Fledglings by Their Parents	117
Chapter X. How the Female Falcon Trains Her Offspring to Hunt	117
Chapter XI. How and Why Falcons Expel Their Young from the Eyrie	118
Chapter XII. Of the Residence Chosen by Young Birds While in the Land of Their Birth	118
Chapter XIII. When Birds of Prey Go Forth to Hunt for Food . .	118
Chapter XIV. Of the Migration of Birds of Prey	118
Chapter XV. Of the Season of the Year Chosen by Predatory Birds for Migration	119
Chapter XVI. Of the Localities from and to Which Birds of Prey Migrate	119
Chapter XVII. Of the Return of Birds of Prey to Their Eyries, and of the Conditions under Which the Journey Is Made	119
Chapter XVIII. How to Recognize Falcons by Their Form and Plumage, and How to Select the Best	119
Chapter XIX. Of the Gerfalcon	120
Chapter XX. Of the Plumage of Gerfalcons	121
Chapter XXI. Of the Finest Plumage in Gerfalcons	121
Chapter XXII. Of the Saker Falcon	121
Chapter XXIII. Of the Plumage of Saker Falcons	121
Chapter XXIV. Of Peregrine Falcons	122
Chapter XXV. Of Brown, Reddish, and Fawn-Colored Peregrine Falcons	124

	PAGE
Chapter XXVI. Of Undesirable Plumage in Peregrine Falcons . . .	124
Chapter XXVII. Of the True (Gentle or) Noble Falcons	124
Chapter XXVIII. Of Lanner Falcons	127
Chapter XXIX. On Sparrow Hawks	127
Chapter XXX. Of the Differences between Nestlings and Branchers	128
Chapter XXXI. On the Methods of Capturing Falcons, and of Their Care and Feeding	128
Chapter XXXII. How to Reach the Eyrie	129
Chapter XXXIII. Of the Enclosures for Falcons and of Their Feeding	129
Chapter XXXIV. Of the Number of Meals and Hours of Feeding for Falcons	135
Chapter XXXV. Of the Best Hours for Feeding Hunting Birds . .	136
Chapter XXXVI. Of the Hack House for Eyases and Its Uses . .	136
Chapter XXXVII. Of the Seeling of Falcons	137
Chapter XXXVIII. Of Jesses and How They Are Fitted	138
Chapter XXXIX. Of the Leash, Its Preparation and Its Uses . . .	139
Chapter XL. Of the Swivel, Its Uses and Method of Fastening . .	140
Chapter XLI. Of the Falcon's Bell	140
Chapter XLII. How to Carry a Falcon on the Hand	143
Chapter XLIII. How to Catch Branchers and Other Wild Falcons .	144
Chapter XLIV. Of the Localities Where Falcons Are Captured . .	145
Chapter XLV. Of the Seeling of Falcons Caught Wild	146
Chapter XLVI. Of Methods of Carrying Falcons and Holding Them on the Fist	149
Chapter XLVII. Of Falconers and Their Qualifications	150
Chapter XLVIII. Of Classes of Falconers and of the Aims of the True Falconer	151
Chapter XLIX. Of Training a Falcon to Stand on the Fist, and of Other Steps in Manning	157
Chapter L. Of the Perches and Blocks on Which Falcons May Rest .	160
Chapter LI. Of the Use of Various Stools and Perches	162
Chapter LII. Of the Unrest and Bating of Seeled Falcons	169
Chapter LIII. Of the Training of the Seeled Falcon through the Senses of Taste, Hearing, and Touch	170

	PAGE
Chapter LIV. On the Taming of Falcons by the Gradual Restoration of Eyesight	171
Chapter LV. Of the Manning of Sighted Falcons	173
Chapter LVI. Of Various Forms of Bating	175
Chapter LVII. On the Causes of Bating	178
Chapter LVIII. On the Signs and Symptoms of Bating	178
Chapter LIX. How to Avoid Unrest and Bating in Falcons	179
Chapter LX. On the Position of Sighted Falcons on the Perch	182
Chapter LXI. Further Remarks on the Taming of Sighted Falcons Held on the Fist	184
Chapter LXII. Of the Taming of Falcons on Foot and on Horseback	189
Chapter LXIII. How to Carry a Falcon Out of and Into the Mews through a Doorway	189
Chapter LXIV. Where the Falcon Should Be Taken for Her First Airing	189
Chapter LXV. When the Falconer Should Carry the Falcon Back to the Mews	190
Chapter LXVI. How a Falcon Replaced in the Mews Becomes Restless and Bates Frequently	190
Chapter LXVII. On Some Remedies for Restlessness and Bating	190
Chapter LXVIII. On Sprinkling the Falcon with Water	190
Chapter LXIX. On the Falcon's Bath	191
Chapter LXX. On the Taming of Falcons on Horseback, and of the Most Suitable Hours for This Training	193
Chapter LXXI. The Falconer on Horseback and His Equipment	194
Chapter LXXII. On the Transport and Surroundings of Untamed Falcons When on a Journey	195
Chapter LXXIII. On Transporting Falcons through Various Regions	201
Chapter LXXIV. Of the Unrest and Bating of Falcons Whether on the Fist or on the Perch	202
Chapter LXXV. Further Remarks on Remedies for the Falcon's Unrest and Bating	202
Chapter LXXVI. On the Faulty Carriage of a Falcon on the Fist; Its Signs and Symptoms	203

	PAGE
Chapter LXXVII. On the Training of the Falcon by Means of the Hood	205
Chapter LXXVIII. Of the Forms, Manufacture, and Uses of the Falcon's Hood	206
Chapter LXXIX. Of the Proper Place for and Manner of Hooding the Falcon	207
Chapter LXXX. On Objections to the Hood on the Part of the Falcon and How to Deal with Them	208
BOOK III. ON THE USE OF THE LURE; ON TRAINING FALCONS TO FLY IN A CAST; ON EDUCATING GERFALCONS TO FLY AT CRANES; AND ON HOUNDS USED IN FALCONRY	225
Author's Preface	225
Chapter I. On the Lure Made of Wings of the Crane	225
Chapter II. On Various Classes of Falconers Who, Reprehensibly, Do Not Use a Lure	227
Chapter III. On the Method of Luring with a Live Bird	228
Chapter IV. The Emperor's Method of Luring	229
Chapter V. On the Use of the Creance in Luring	230
Chapter VI. Of How to Approach a Falcon Standing on the Lure	231
Chapter VII. On Feeding a Falcon on the Lure; and on How to Lift Her from It for Repeated Practice Flights	232
Chapter VIII. On the Choice of a Locality for the First Outdoor Trials with the Lure	237
Chapter IX. Of the Weather and Hours Suitable for Luring; and of Further Particulars Concerning the Use of the Lure	238
Chapter X. Of Final Instructions for Practice with the Lure, before the Falcon Is Released from the Creance	239
Chapter XI. Of Luring the Falcon on Foot without the Creance	241
Chapter XII. On Luring the Falcon on Horseback, and on Certain Precautions to Be Observed	241
Chapter XIII. How Falcons Are Lured in Britain	243
Chapter XIV. On Falcons Who Refuse to Come to the Lure	244
Chapter XV. On the Characteristics of Proper Flight; Also on Signs of Injury or Fatigue in Falcons	244
Chapter XVI. On Testing Falcons to Be Flown in a Cast	246
Chapter XVII. How to Teach Falcons to Co-operate When Flown in a Cast; and on the Use of the Hare-Train and the Make-Falcon	248

	PAGE
Chapter XVIII. On Falcons Flown in a Cast Who Crab While Standing on the Quarry	250
Chapter XIX. On Hunting with the Gerfalcon and on Various Conditions That Affect Her Flying Powers	250
Chapter XX. On the Gerfalcon's Preliminary Education in Hunting, and on the Use of a Hare-Train	252
Chapter XXI. On Flights of Gerfalcons at Small Birds; and Other Pertinent Considerations	256
Chapter XXII. On Entering a Gerfalcon to the Crane-Train, and on the Preparation of That Device	257
Chapter XXIII. The Education of the Gerfalcon with the Crane-Train	258
Chapter XXIV. How to Teach a Falcon to Recognize the Call of the Crane; and on Other Matters Pertaining to the Train	261
Chapter XXV. The Use of a Walking Crane in the Education of the Gerfalcon	262
Chapter XXVI. On Entering a Gerfalcon to a Captive Flying Crane; Also How to Post Assistants	262
Chapter XXVII. On the Value of the Train in the Education of the Gerfalcon	266
Chapter XXVIII. On Hounds Used in Falconry	267
BOOK IV. CRANE HAWKING WITH GERFALCONS AND OTHER FALCONS	273
Chapter I. On Cranes and Their Feeding Habits	273
Chapter II. On the Seasons Best Suited to Crane Hawking in Various Regions	274
Chapter III. On the Proper Weather for Crane Hawking	276
Chapter IV. Of the Hours of the Day When Gerfalcons May Be Flown at Cranes	277
Chapter V. Of the Districts That Are Best Suited for Crane Hawking	278
Chapter VI. Of the Number of Cranes to Which a Novice Falcon May Be Entered	279
Chapter VII. On the Equipment Suitable for a Falconer Hunting Cranes	280
Chapter VIII. On How the Mounted Falconer Separates Two or Three Cranes from a Flock	281
Chapter IX. On the Signs That Cranes Will Remain Quiet While the Falcon Is Being Slipped	282

Table of Contents

XV

	PAGE
Chapter X. On the Posting of Assistants on an Open Plain Free of Obstacles, Either on a Quiet Day or When a Breeze Is Blowing .	283
Chapter XI. Of Posting Assistants on a Plain Where There Are Impediments to the Hunt, Both in a Breeze and When the Air Is Quiet	284
Chapter XII. On Posting Assistants on a Hillside under Various Conditions of Wind and Terrain	285
Chapter XIII. On the Position of the Falconer in a Breeze on a Plain without Obstacles	285
Chapter XIV. On the Post of the Falconer in a Breeze on a Plain with Obstacles	286
Chapter XV. On the Position of the Falconer on a Hillside That Presents No Obstacles, on Either a Windy or a Quiet Day . . .	286
Chapter XVI. On the Position of the Falconer on a Hillside with Obstacles and on Either a Windy or a Quiet Day	287
Chapter XVII. On Certain Precautions to Be Observed in Slipping a Gerfalcon at Cranes; Also on the Use of Hounds	288
Chapter XVIII. On Encircling the Cranes on Horseback before Slipping the Falcon	288
Chapter XIX. On the Nature of the Assistance to Be Given a Gerfalcon When Flying at Cranes	289
Chapter XX. On the Gerfalcon That Binds to Her Quarry	290
Chapter XXI. On the Gerfalcon Unable to Bind to Her Prey, and on the Proper Treatment of That Condition	293
Chapter XXII. On the Reasons for a Falcon's Inability to Bind to Her Quarry and on the Methods Used to Correct These Defects .	294
Chapter XXIII. On Entering the Gerfalcon to Fly Singly at Cranes; and of the Use of a Make-Hawk	296
Chapter XXIV. On Entering Two Novices Simultaneously to Cranes	298
Chapter XXV. On the Various Modes of Flight Displayed by Falcons Entered to Standing Cranes	299
Chapter XXVI. On the Various Modes of Flight Displayed by Falcons Entered to Cranes on Passage	300
Chapter XXVII. Of Shirkers and the Treatment of Their Infirmities	303
Chapter XXVIII. Of Cowards and How to Deal with Them . .	306
Chapter XXIX. How Other Species of Falcons Compare with Gerfalcons and with Each Other as Hunters of Cranes	309

	PAGE
BOOK V. HERON HAWKING WITH SAKERS AND OTHER FALCONS	317
Chapter I. On the Education of Sakers by Means of the Heron-Lure and the Heron-Train	317
Chapter II. On the Feeding of Herons Kept for Use in the Train .	317
Chapter III. On Flying Sakers at the Heron-Train	318
Chapter IV. On the Seasons When Herons Are Found in Various Regions; and on Their Nesting and Feeding Habits	320
Chapter V. On the Best Season for Educating a Saker to Hunt Hérons	323
Chapter VI. On the Weather and the Hours of the Day Best Suited to Heron Hawking	324
Chapter VII. Of Localities Suited to Heron Hawking	325
Chapter VIII. On Driving Away Birds at Which a Falcon May Check	325
Chapter IX. On the Number of Herons at Which a Falcon May Properly Be Flown; and on Posting Assistants at the River . .	326
Chapter X. On General Precautions to Be Observed in Slipping a Falcon and in Putting Up Herons	326
Chapter XI. On the Utility of Dogs in Heron Hawking	328
Chapter XII. On Heron Hawking at the River	329
Chapter XIII. On the Treatment to Be Accorded a Falcon That Has Captured Her Prey	330
Chapter XIV. On Certain Risks in the Use of Trained Hounds . .	330
Chapter XV. On the Reasons Why a Falcon May Fail to Capture a Heron	336
Chapter XVI. On the Behavior of a Saker That Fails to Capture Her Prey; and What the Falconer Should Do under Various Circum- stances	336
Chapter XVII. On Special Correctives for a Falcon's Improper Be- havior	338
Chapter XVIII. On the Utility of a Make-Falcon	339
Chapter XIX. On How to Fly a Novice with a Make-Falcon . . .	340
Chapter XX. On Four Characteristic Modes of Flight Exhibited by Falcons Flown at Herons	342
Chapter XXI. On Heron Hawking with Sakers Swift in Flight, but Fearful of Watery Areas	342
Chapter XXII. On Heron Hawking with Sakers Slow in Flight, but Having No Fear of Water	344

	PAGE
Chapter XXIII. On Heron Hawking with Sakers That Are Both Swift and Fearless	345
Chapter XXIV. On the Environment Desirable and on the Precautions to Be Observed When Flying a Saker That Is Both Slow and Timid over Water	345
Chapter XXV. On Special Hazards Caused by Wind and Unfavorable Terrain When Flying Falcons at Herons on the River . .	346
Chapter XXVI. On How to Test the Flying Powers of a Fine Falcon	348
Chapter XXVII. On Flying Sakers at a Heron on Passage	349
Chapter XXVIII. On the Flight of Eyases Entered to Herons . .	350
Chapter XXIX. On the Flight of Branchers Entered to Herons . .	351
Chapter XXX. On the Special Attention to Be Given Individual Falcons	352
Chapter XXXI. On How Other Species of Falcons Compare with the Saker and with Each Other as Hunters of Herons	353
BOOK VI. HAWKING AT THE BROOK WITH THE PEREGRINE FALCON	363
Chapter I. On Flying Peregrines at Waterfowl, and on the Lure Made of the Wings of Mallard Drakes	363
Chapter II. On Various Types of Peregrines and How to Select the Best	364
Chapter III. On Calling a Peregrine to the Lure; on Teaching Her to Like It and to Heed Her Master's Voice	365
Chapter IV. On the Dangers of a Hurried Education with the Lure; and on the Premature Employment of a Peregrine in Hawking .	366
Chapter V. On Reasons Why the Falcon May Not Be Attracted by the Lure	366
Chapter VI. On Training the Peregrine to Wait On; and on the Weather and Hours Preferred for That Exercise	369
Chapter VII. On the Best Environment for Waiting On; and on the Obstacles to Be Avoided	370
Chapter VIII. On Eight Modes of Behavior of Falcons Sent Up to Wait On	372
Chapter IX. On the Education in Waiting On Required for a Superior Peregrine	373

	PAGE
Chapter X. How to Correct the Flight of Falcons Who Fly Low in Waiting On	379
Chapter XI. How to Correct the Flight of a Falcon Who Flies Low and Goes to Perch Near By	380
Chapter XII. On the Education in Waiting On of a Falcon Who Goes at Once to Perch Close at Hand	381
Chapter XIII. On the Falcon That Flies Off after Waiting On at a High Pitch	381
Chapter XIV. On Two Classes of Falcons That Wait On at a Low Pitch and Then Fly Away	382
Chapter XV. On Falcons of the Least Valuable Class Who Do Not Wait On but Fly Away to Perch at a Distance	383
Chapter XVI. On the Seasons, Hours, and Weather Best Suited to Hawking at the Brook	384
Chapter XVII. On Various Localities Where Hawking at the Brook May Be Practiced	385
Chapter XVIII. On the Modes of Flight Exhibited by Peregrines Hawking at the Brook; and of the Environment and Routine Required for Testing Falcons	386
Chapter XIX. On Falcons That Rake Away before Ducks Are Put Up	388
Chapter XX. On the Causes of a Falcon's Raking Away, and on Those That Have the Most Serious Results	389
Chapter XXI. How to Determine the Cause of the Falcon's Raking Away	391
Chapter XXII. How to Recover a Nomadic Falcon	391
Chapter XXIII. On the Modes of Flight of Birds That Cause a Falcon to Rake Away	393
Chapter XXIV. On the Distress Caused a Falcon by the Interference of Other Birds	394
Chapter XXV. On Signs of Distress in a Falcon; and How the Falconer Must Act to Prevent Her Raking Away	398
Chapter XXVI. How to Put Up Quarry for a Falcon Waiting On	400
Chapter XXVII. On the Various Fashions in Which Peregrines Stoop at Ducks over Water; on Capture of Their Quarry, and on Their Proper Reward	401
Chapter XXVIII. On Falcons That Capture Ducks Away from the Water; and on Their Treatment	402

Table of Contents

xix

	PAGE
Chapter XXIX. On Falcons That Fail in the Stoop to Capture a Duck, and on Their Subsequent Behavior and Treatment . . .	404
Chapter XXX. On the Danger of Flying a Falcon in the Presence of an Avian Species at Which She Has Previously Checked and on Which She Has Made a Meal	408
Chapter XXXI. On Falcons That Have No Taste for Ducks; and on the Falconer Who Has Mistaken Some Other Object for a Duck .	409
Chapter XXXII. On Ducks That Rise of Their Own Accord . . .	411
Chapter XXXIII. On Falcons That Fail to Capture Quarry Returning to Its Watery Refuge	412
Chapter XXXIV. On Encouraging the Return of a Falcon That Has Raked Away	413
Explicit, with Great Seal of Frederick II of Hohenstaufen	415
 APPENDED MATERIAL	 417
THE MEWS, ITS FURNITURE AND ACCESSORIES	419
DISEASES OF AND ACCIDENTS TO HAWKS, AND THEIR TREATMENT	425
METHODS, ANCIENT, MEDIEVAL, AND MODERN, FOR THE CAPTURE OF FALCONS AND OTHER BIRDS OF PREY, by <i>Captain R. Luff Meredith</i>	433
FALCONRY IN MODERN TIMES, by <i>Walter Schlüter</i>	451
COINS AND MEDALS DEPICTING FALCONS AND FALCONRY, from the Collection of <i>Hugh D. Knight</i>	471
NOTES ON THE ST. GORGON STATUE, by <i>Gordon Washburn</i>	473
A SHORT ACCOUNT OF THE HOHENSTAUFEN AND NORMAN ANCESTORS OF FREDERICK II AND OF HIS DESCENDANTS	475
NOTES ON THE PORTRAITS OF EMPEROR FREDERICK II AND OF HIS SON MANFRED .	503
 FAVORITE BIRDS OF THE CHASE PROBABLY WELL KNOWN TO THE EMPEROR	 507
 ANNOTATED ROSTER OF BIRDS THAT ARE MENTIONED, DEPICTED BY, AND WERE PROBABLY FAMILIAR TO EMPEROR FREDERICK II	 531

	PAGE
AN ANNOTATED BIBLIOGRAPHY OF ANCIENT, MEDIEVAL, AND MODERN FALCONRY	559
GLOSSARY AND INDEX	611
COMBINED LATIN-ENGLISH AND ENGLISH-LATIN GLOSSARY OF WORDS, TERMS, AND EXPRESSIONS PECULIAR TO ANCIENT, MEDIEVAL, AND MODERN FALCONRY . .	613
GENERAL INDEX	631



LIST OF ILLUSTRATIONS

	PAGE
PLATE 1.—Portrait of Frederick II <i>Frontispiece</i>	iii
PLATE 2.—Casey A. Wood <i>preceding</i>	vii
PLATE 3.—Folio 1 ^r from the Vatican MS. Pal. Lat. 1071, with portraits of the Emperor Frederick II and of King Manfred with his falconers	xxxix
PLATE 4.—Folio 3, Bibliothèque Nationale MS. Fr. 12400, showing the Emperor receiving his falconers	xxxii
PLATE 5.—Folio 5 ^r of the Vatican MS. Pal. Lat. 1071, with King Manfred shown as a falconer	xxxiii
PLATE 6.—Portrait of King Manfred receiving the Bible prepared for him	xxxiv
PLATE 7.—Two specimens of the Augustales of Frederick II	xliii
PLATE 8.—General view of Castel del Monte in Apulia	xliv
PLATE 9.—The Emperor's throne from the audience chamber of Castel Gioja del Colle	xlv
PLATE 10.—Loggia in the courtyard of Castel Gioja del Colle near Bari	xlvi
PLATE 11.—Incipit from the Bologna Codex of the <i>De Arte Venandi cum Avibus</i>	liii
PLATE 12.—Incipit from the Mazarine MS. 3716, showing Royal Falconer mounted	liv
PLATE 13.—Incipit from the Valencia MS. 402, showing initial and decoration	lv
PLATE 14.—Lower section of the first folio of the Vatican MS. Pal. Lat. 1071	lvi
PLATE 15.—Folio 1 of the French translation in the Bibliothèque Nationale (MS. Fr. 12400) illuminating the Translator's Prologue	lxiii
PLATE 16.—Incipit from the Geneva MS. Fr. (Petau) 170	lxiv
PLATE 17.—Incipit from the Württembergische Landesbibliothek MS. H.B. XI 34-c	lxv
PLATE 18.—Title page and page 1 of Marcus Velsler's edition of the <i>De Arte Venandi cum Avibus</i>	lxvi
PLATE 18a.—Title page and page 1 of the German translation of Velsler's edition by Pacius	lxvii
PLATE 19.—Incipit from the Vienna Codex of the <i>De Arte Venandi cum Avibus</i>	lxviii
PLATE 20.—Folio 35 ^v , Bologna copy of the <i>De Arte Venandi cum Avibus</i>	lxxvii

	PAGE
PLATE 21.—Incipit from <i>Le Livre de la Chasse</i> of Gaston Phebus, Comte de Foix (Geneva MS. Petau 169)	lxxviii
PLATE 22.—Incipit from a copy of <i>Le Livre de la Chasse</i> bound in with the Stuttgart Manuscript of the <i>De Arte Venandi cum Avibus</i>	lxxix
PLATE 23.—Folio 34, Bologna copy of the <i>De Arte Venandi cum Avibus</i> , showing change in script	lxxx
PLATE 24.—Map of southern Italy and Sicily showing the location of the Emperor's castles and hunting lodges	xci
PLATE 25.—Fortress of Lucera (1233)	xcii
PLATE 26.—Plan of the Emperor's Saracen camp at Lucera	xciii
PLATE 27.—Remains of the entrance portal of Frederick's palace at Foggia	xciv
PLATE 28.—Main portal of Castel del Monte	xcix
PLATE 29.—View of an upper-floor room at Castel del Monte	c
PLATE 30.—Plans and section of Castel del Monte, Apulia	ci
PLATE 31.—The Castle of Lagopesole	cii
PLATE 32.—A falcon's nest with three eggs, taken on one of the towers of Castel del Monte, 1938	cvii
PLATE 33.—Near view of Castel del Monte, erected in 1240	cviii
PLATE 34.—Bronze ram, from the entrance to the Emperor's Castle at Syracuse, Sicily	cix
PLATE 35.—Remains of Frederick's "Parco per Uccellagione" at Gravina in Apulia	cx
PLATE 36.—Three views of falconers and their charges (in color)	facing 3
PLATE 37.—Folio 2 of the French translation of the <i>De Arte Venandi cum Avibus</i> (Bibliothèque Nationale MS. Fr. 12400)	11
PLATE 38.—Folio 6 ^r from MS. Fr. 12400 with drawings of birds	12
PLATE 39.—Folio 4 ^v from Vatican MS. Pal. Lat. 1071, containing drawings of birds.	13
PLATE 40.—King Manfred portrayed as a falconer (Bibliothèque Nationale MS. Fr. 12400)	14
PLATE 41.—Portal of the Cathedral at Bitonto (1200)	23
PLATE 42.—Courtyard of Gioja del Colle, a favorite hunting retreat of the Emperor	24
PLATE 43.—Palace at Gioja del Colle, built for the Emperor's falcons and falconers	25
PLATE 44.—Fish hawk, or osprey	26
PLATE 45.—Folio 15 from the Vatican Codex showing birds in migration	35
PLATE 46.—Folio 16 from the Vatican Codex with flying ducks, geese, and storks	36
PLATE 47.—Page from the French manuscript with flying ducks, geese, and storks	37
PLATE 48.—Page describing and illustrating birds' crests	38
PLATE 49.—Adult hobby (<i>Falco subbuteo</i> , Linnaeus)	47

	PAGE
PLATE 50.—Adult female merlin (<i>Falco aesolon</i> , Tunstall)	48
PLATE 51.—Page from the Vatican Codex showing variations in birds' heads (folio 18)	65
PLATE 52.—Drawings from folio 29 ^v (Vatican Codex) to illustrate the discussion of birds' beaks and the sounds they produce	66
PLATE 53.—Lower portions of Vatican MS. folios showing illustrations of text on birds' necks and shoulders	67
PLATE 54.—Illustrations showing variations in shape of birds' beaks (Vatican MS.) . .	68
PLATE 55.—Folio 20 ^v , Bibliothèque Nationale MS. Fr. 12400, discussing the return of birds from feeding grounds	85
PLATE 56.—Page illustrating the discussion of birds' legs and feet (folio 26, Vatican Codex)	86
PLATE 57.—Folio 43 from Vatican Codex showing how birds protect their young . . .	87
PLATE 58.—Page discussing self-defense of birds (Bibliothèque Nationale)	88
PLATE 59.—Intermewed eyas peregrine, "Lady Mary"	101
PLATE 60.—Robert Cheseman, falconer of Henry VIII of England	102
PLATE 61.—Philip the Handsome of Burgundy and his falcon (ca. 1550)	103
PLATE 62.—"The Hawk," engraving after E. Landseer	104
PLATE 63.—Hawk in plumage of advanced age, Reichsfalkenhof, Germany	113
PLATE 64.—Section of the Outdoor Refuge, Reichsfalkenhof, Germany	114
PLATE 65.—Hawk on the high perch, Imperial Japanese Falconhouse	115
PLATE 66.—Falcon and falconer from the Imperial Japanese Falconhouse, 1936 . . .	116
PLATE 67.—The French illuminator's idea of the falcon's mews and bath	125
PLATE 68.—Page showing falconers leaving and entering the mews	126
PLATE 69.—Page from the Vatican Codex showing falconers preparing food for their birds (folio 59 ^v)	131
PLATE 70.—Two falconers coping the talons of a hunting-bird, and designs for making and tying a jess (Vatican MS. Pal. Lat. 1071)	132
PLATE 71.—Accouterments of a hunting falcon	141
PLATE 72.—Hawk's furniture, including purses and patterns for making the hood . .	142
PLATE 73.—Common form of block perch for weathering falcons	147
PLATE 74.—One of many types of the padded cadge for perching falcons	148
PLATE 75.—Sixteenth-century noble in falconer's regalia with falcon on fist	153
PLATE 76.—Six-foot wooden figure of St. Gorgon, with falcon	154
PLATE 77.—Lateral view of the statue of St. Gorgon	155
PLATE 78.—Part of a folio showing falconer swimming to the rescue of his bird . . .	156

	PAGE
PLATE 79.—Drawings showing the high perch; and the recently captured falcon wrapped in a sock	165
PLATE 80.—Spraying the falcon; handling and feeding the falcon	166
PLATE 81.—The block perch for hacking falcons and the bow perch for hawks	167
PLATE 82.—The lanner (after Gould)	168
PLATE 83.—Examples of low perches from folio 54 of the Vatican Codex	185
PLATE 84.—The high perch from a page of the Vatican Codex (folio 92 ^v)	186
PLATE 85.—Falconers demonstrating the incorrect method of holding the falcon when mounting a horse, from the Bibliothèque Nationale MS. Fr. 12400	187
PLATE 86.—Unfinished miniature in the Vatican Codex showing a falconer in the act of mounting (folio 98)	188
PLATE 87.—Hawking costume of a young nobleman of the reign of Henry III (1250)	197
PLATE 88.—Falcon's hoods, sixteenth century	198
PLATE 89.—Elector Clemens August of Cologne and his favorite falcon	199
PLATE 90.—The Mogul Emperor Jahangir and a favorite falcon	200
PLATE 91.—Hoods and their arrangements	209
PLATE 92.—Adult male Norway falcon (after Brodrick)	210
PLATE 93.—Adult male sparrow hawk	211
PLATE 94.—Greenland falcon. Adult tercel	212
PLATE 95.—Doorway in the courtyard of Castel del Monte	221
PLATE 96.—Fragment of the original twelfth-century ceiling of the Cappella Palatina	222
PLATE 97.—Group of pillars in the cloister of the Cathedral of Monreale	223
PLATE 98.—General view of the terrain surrounding Castel del Monte	224
PLATE 99.—Reichsfalkenhof of the German Falkenorden	233
PLATE 100.—Outdoor shelter for falcons, Reichsfalkenhof, Germany	234
PLATE 101.—"Mushroom" refuge for hunting-birds in the Reichsfalkenhof	235
PLATE 102.— <i>Falco peregrinus anatum</i> , "Lady"	236
PLATE 103.—Upper-floor room, Castel del Monte, considered to be Frederick's bedroom	253
PLATE 104.—Antique casket decorated with hunting scenes	254
PLATE 105.—Doorway and arch of Castel del Monte showing mixed architectural styles	263
PLATE 106.—Tomb of Roger II, king of Sicily and grandfather of Frederick II	264
PLATE 107.— <i>Hierofalco hoeboelli</i> , adult male	271
PLATE 108.—Greenland falcon, <i>Falco candidans</i> , Gmelin	272
PLATE 109.—"Casting Off the Falcon." A Ridinger print	291
PLATE 110.—Two lateral panels of the Great Fountain in Perugia	292

	PAGE
PLATE 111.—“The Fair Huntress Phyllis,” from an engraving by August Vind . . .	301
PLATE 112.—Persian falconer, from a drawing in the Bibliothèque Nationale . . .	302
PLATE 113.—Female adult saker, <i>Falco saker</i>	313
PLATE 114.—Barbary falcon (after Brodrick and Salvin)	314
PLATE 115.—Adult male hobby	315
PLATE 116.—Female merlin, immature	316
PLATE 117.—Episcopal throne in the cathedral at Canosa	331
PLATE 118.—Cathedral of Bitonto (1200)	332
PLATE 119.—Façade of the Cathedral of Trani, showing details of bronze doors . . .	333
PLATE 120.—Norman apse of Palermo Cathedral, where Frederick II of Hohenstaufen is buried	334
PLATE 121.—Mature female peregrine, <i>Falco peregrinus</i> , var. <i>Calidus</i>	359
PLATE 122.— <i>Falco peregrinus</i>	360
PLATE 123.—Iceland falcon	361
PLATE 124.—Female peregrine, “Diane”	362
PLATE 125.—Initial letter of the Incipit of Book VI, <i>De Arte Venandi cum Avibus</i> , Bo- logna Codex MS. Lat. 419 (717)	375
PLATE 126.—“The Return Home.” Hawking in the fourteenth century	376
PLATE 127.—“Duck-Hawking in the Seventeenth Century.” Print by Howitt . . .	377
PLATE 128.—“A Heron Hunt in 1750.” From the collection of the Landgraf of Hessen- Cassel	378
PLATE 129.—Portion of the Palazzo Reale in Palermo	395
PLATE 130.—Castel Trani, now a prison	396
PLATE 131.—Emilio Caggiano’s statue representing Frederick II of Hohenstaufen, on the façade of the Royal Palace in Naples	405
PLATE 132.—Abbey of the Holy Trinity at Venosa, birthplace of Horace	406
PLATE 133.—Drawings showing falconers spraying and carrying their birds	421
PLATE 134.—The falcon’s mews and bath, from a page of the Vatican Codex	422
PLATE 135.—Folio 92, Vatican Codex, illustrating the causes of bating	423
PLATE 136.—Illustrations showing behavior of falcons properly and improperly carried	424
PLATE 137.—Portable high perch with apron; padded cage for perching falcons . . .	429
PLATE 137a.—Modern high perch with apron or curtain	430
PLATE 138.—Proper method of handling falcons to prevent bating, illustrated in the Vatican MS. Pal. Lat. 1071, folios 89, 89 ^v	435
PLATE 139.—Illustration of falcons’ nests. Vatican MS. Pal. Lat. 1071 (folio 49 ^v) . .	436

	PAGE
PLATE 140.—Copy of the preceding plate in Bibliothèque Nationale MS. Fr. 12400, (folio 80)	437
PLATE 141.—Falconers lowering a man over a cliff to rob a falcon's eyrie	438
PLATE 142.—Trap-noose for capturing falcons; diagram showing arrangement for capturing migratory birds of prey	443
PLATE 143.—Stationary trap for the capture of falcons; diagram showing shape and size of a simple avian trapping cage; plain net for catching birds of prey	444
PLATE 144.—Box-cage trap for falcons; one of numerous modifications of the Dho-gaza device for catching hawks	445
PLATE 145.—Device for capturing falcons; general design of Demeritt hawk trap; simple trap for the capture of birds of prey	446
PLATE 146.—Map of Valkenswaard and vicinity	454
PLATE 147.—Karl Mollen of Valkenswaard, Holland	454
PLATE 148.—A favorite falcon of the Landgrave of Hesse-Cassel	455
PLATE 149.—"Falconers Fleming of Barochan, Anderson, and Harvey." From an old print	456
PLATE 150.—Transport for falcons and their equipment	457
PLATE 151.—Weathering space for falcons at hack, Reichsfalkenhof, Germany	458
PLATE 152.—Exhibit of rare books and pictures of the British Falconers' Club at the International Exhibition, Düsseldorf, 1936	463
PLATE 153.—Portion of Falconry Exhibit, McGill University, Montreal, 1939	464
PLATE 153 <i>a</i> .—Portion of the Falconry Exhibit at Montreal, 1939	465
PLATE 154.—Coins and medals depicting birds of the chase and falconry scenes	466
PLATE 155.—Medals depicting falconry scenes	467
PLATE 156.—Coins and medals depicting falcons and falconry	468
PLATE 157.—Coins and medals depicting falcons and falconry	469
PLATE 158.—Coins and medals depicting falcons and falconry	470
PLATE 159.—Frederick II of Hohenstaufen, from a seventeenth-century Italian print	477
PLATE 160.—Crown of Constance of Aragon, first wife of Frederick II	478
PLATE 161.—Tomb of the Empress Constance of Sicily, wife of Henry VI, and mother of Frederick II	479
PLATE 162.—The Emperor Frederick II enthroned. From the Exultet Rolls of Salerno	480
PLATE 163.—Twelfth-century mosaic in the Church of the Martorana, Palermo	489
PLATE 164.—Hunting scene in the chamber of Roger II, Royal Palace, Palermo	490
PLATE 165.—Abbey of the Holy Trinity at Venosa	491

	PAGE
PLATE 166.—Remains of a laurel-crowned stone head found near Castel del Monte; damaged bust (probably) representing one of Frederick's favorite falconers	492
PLATE 167.—Page from the Manesse Manuscript at Heidelberg	499
PLATE 168.—Statue of Conradin, or Conrad the Young	500
PLATE 169.—Second view of the statue of Conradin, by Thorwaldsen	501
PLATE 170.—"Il Falconiere," painting by Tranquillo Cremona	502
PLATE 171.—Mature female saker (after Brodrick)	511
PLATE 172.—Immature female hobby (after Brodrick)	512
PLATE 173.—Goshawk, immature female (after Brodrick)	513
PLATE 174.—Sparrow hawk (after Bowdler Sharpe)	514
PLATE 175.—Golden eagle (<i>Aquila chrysaetus</i> , var. <i>canadensis</i>) owned by H. H. Ivor	521
PLATE 176.—Golden eagle (second view)	522
PLATE 177.—Hunting eagle, Reichsfalkenhof, Germany	523
PLATE 178.—Intermewed female goshawk, "Tamar," six-year-old eyas, 1937	524
PLATE 179.—Title page of <i>Latham's Falconry</i>	533
PLATE 180.—A Byzantine royal portrait, illustration on a folio of the Vatican Codex MS. Graec. 695	534
PLATE 181.—Tomb of the Emperor Frederick II of Hohenstaufen in the Cathedral at Palermo	535
PLATE 182.—Portrait of Asaf Khan, Minister of Shah-Jehan (seventeenth-century)	536
PLATE 183.—Corner tower of the Fortress of Lucera, rebuilt by Charles of Anjou in 1281	545
PLATE 184.—Church of SS. Nicolo e Cataldo, Lecce, said to have been founded by Tancred	546
PLATE 185.—Vestibule of the Palace of La Zisa, Palermo, built by William I	547
PLATE 186.—Tomb of Bohemond, Prince of Antioch, at Canosa in Apulia	548





Translators' Introduction



PLATE 3.—Portraits of Emperor Frederick II (upper figure) and King Manfred and his falconers (shown below) from the *De Arte Venandi cum Avibus* (Vatican MS. Pal. Lat. 1071, fol. 1^v). To be compared with Plate 37 (p. 11).

la besoingne de cest art. et par
 ce nous prions a chascun noble ho
 me qui par droite noblesce se do
 it entendre et occuper en cest li
 ure que il le face lire et appre
 nre par aucun sage de plusieurs sci
 ences. Et me pardonne ce que te
 ai moins dit. Car come li ars
 art ces propres mos et ces pro
 pres paroles li com li autre art.
 et nous ne triuissans en gramai
 re paroles de l'art couuenable
 en toutes choses. Nous mesmes
 es celles qui miez nous sembler
 estre propres et prochaines a ce
 que nre entencion seust estre
 entencions. Donques la matie
 re de cest liure li est li ars de chac
 al oustans des parties dou que il
 liure vne si est en contemplati
 on en sachant. La quelle est dite
 theorique. L'autre li est en ouure
 qui est nommee pratique. De
 techies il ia une partie de la ge
 neral contemplation. tant de ce
 les choses qui appartenent a la
 theorique come de celles qui re
 gardent la pratique. Les au
 tres parties de l'espaual conside
 ration sont de celles mesmes

choses. Nostre entencion est ma
 nifester en cest liure les choses
 qui appartenent et sont de la
 chose des oustans. ninsi es elles
 sont et acertaines d'art rame
 ner des quelles choses nous nor
 onques ne science ne art jusques
 a. La maniere d'art et auant est
 par prose par probleme et par ex
 ecucion. la maniere de l'execucion
 est plusieurs. et en partie il de
 uise. En partie il desire. En partie
 il assigne les conuenances qui
 succedent de cest art. et les dis
 tences au li des choses de quoi
 il traite en cest liure et si sont
 autres manieres les quels nous
 enseuons li com il appara en
 liure. Et auchoins est ions de
 grant noblesse en qui s'ours
 et ameres de sapience et apela
 di. nels augustes frederis secons
 empereur de roine de iblm. et
 de ceille roys. Li profit qui iuet
 de cest liure est grants. car li no
 ble et li puissant qui sont auan
 sonner selonc les gouuernemens
 des choses dou monde par lus
 de cest art entremetront a la
 fois totes a lor aires et li poure



PLATE 4.—The Emperor receiving his falconers, Bibliothèque Nationale MS. Fr. 12400,
 fol. 3. Compare with Plate 14, p. lvi.

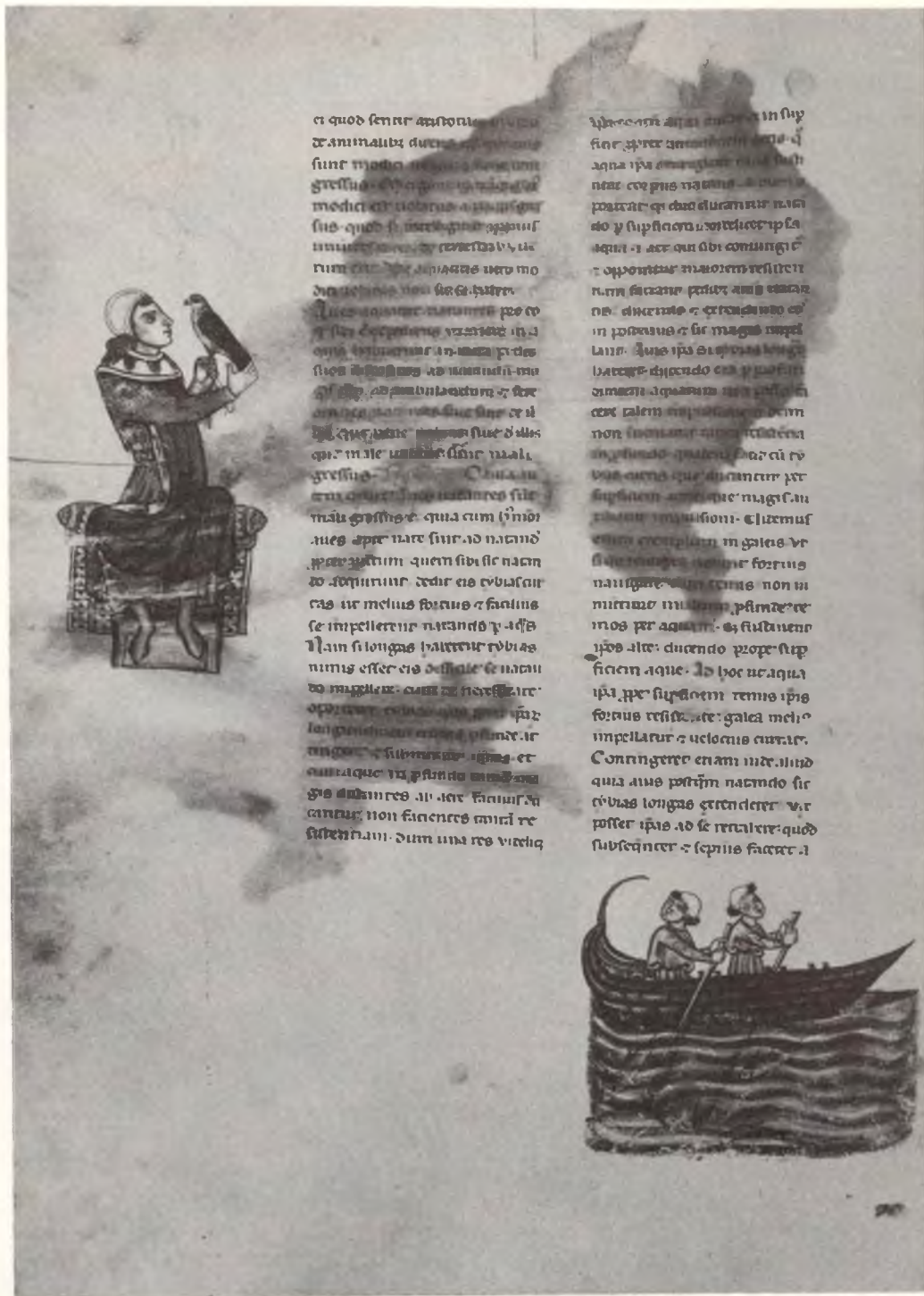

PLATE 5.—King Manfred (above) as a falconer, beside the text of the first of his additions to the *De Arte Venandi* (fol. 5^r of the Vatican MS. Pal. Lat. 1071). Compare the costume with that on the corresponding figure in the French translation, Plate 40 (Bibliothèque Nationale MS. Fr. 12400).



PLATE 6.—Portrait of King Manfred receiving the Bible prepared for him (Biblioteca Vaticana, Lat. 36, fol. 522). The figures of the men presenting it recall so strikingly those of the Vatican Codex that they may well have been drawn by the same hand.

TRANSLATORS' INTRODUCTION

ALTHOUGH the "noblest of arts" reached its climax in the Middle Ages, it was known and practiced many centuries earlier in Far Eastern lands. *Ex oriente lux*. In the very cradle of our race was first established the curious custom of training birds of prey to capture other animals for sport and food. Indeed, it was coeval with the shadowy advances of so-called civilization; it was born in and emerged from the mists of remote antiquity. There is evidence to prove, for example, that falconry was familiar to the peoples of China, ancient India, Assyria, Sumeria, and the other provinces of Babylonia, Egypt, and Persia thousands of years before Rome came into existence.

Consequently the Emperor Frederick II, if not the earliest, the most brilliant and most versatile exponent of the art of educating birds for the chase, occupied historically, one might say, a place much more toward the decline rather than at the rise of the aristocratic sport of catching birds by means of birds.

As Abram points out in his masterly monograph,¹ the sport pre-eminently associated in our minds with the Middle Ages is hawking. And, indeed, it owed its existence to conditions of life then prevailing; for in the days when there were only feeble and clumsy guns, or none at all, the only chance of bringing down birds which flew out of the range of arrows was to send falcons after them. To say that people were fond of hawking would be far too mild a way of expressing their feelings; they had quite a passion for it, and valued

their hawks more than anything else they possessed. "I axe no more gods [goods] of you for all the servyse I shall do you whyll the world standyth, but a goss-hawke," writes John Paston to his brother.

As a preface to a rendering into English of the *De Arte Venandi cum Avibus* by Emperor Frederick II, it is important to observe that that remarkable man's many and varied accomplishments were not confined to his avian discourses and discoveries.²

It must be borne in mind that, despite the constant demands made on him by administrative, political, military, and other engagements, the Emperor never forgot the absorbing recreations inherent in the pursuit of falconry (which he styled the noblest of sports) and his other bird studies. It would indeed be difficult to decide, for instance, which occupied most of his waking hours, his (and other people's) falcons or his plans of campaign. For example, he failed disastrously in one important engagement because he made the mistake of indulging in a day of sport with his birds instead of pressing the siege of a fortress—evidently one cannot serve simultaneously both Mars and St. Hubert. Some writers believe this devotion to the practice of falconry to have been a hereditary trait—that the sport had been introduced into Italy by one of Frederick's grandparents, the famous Barbarossa.

Frederick II of Hohenstaufen, Holy Roman Emperor, King of Sicily and Jerusalem, was the son of the Emperor Henry VI. He was directly descended, through his mother,

² The reader is further referred to other sections of the present work where a number of the subjects of this Introduction are more fully treated.

¹ A. Abram, *English Life and Manners*, p. 230 (*vide* the "Paston Letters").

Constance of Sicily, from Roger I, Norman ruler of Sicily, himself a son of Tancred de Hauteville. It may here be said, parenthetically, that under these Norman kings the arts of peace, manufactures, agriculture, architecture, and other cultural pursuits flourished, and that Sicily and southern Italy increased thereby in national prosperity and European influence.

Frederick's political career, punctuated as it was by disputes and claims attending his German, Italian, and Oriental interests, furnishes one long account of sieges, battles, crusades, wars, and intrigues of a religious, social, and geographical character, waged chiefly with the Pope and with numerous other European and Eastern potentates, the details of which have no place here. As we are mostly interested in his avian relations, we may appropriately refer to him as a stormy petrel flying over mid-Europe and the Near East during his brief but ever active life. He died at the early age of fifty-six, one of the most versatile and interesting men of medieval times. Contemporary opinion of him is expressed in the phrase, *stupor mundi et immutator mirabilis*.

Frederick had more than a mere bowing acquaintance with at least six languages. Judged by modern standards he was licentious and luxurious in his manners but catholic and cultured in his tastes. His wives and concubines were kept in seclusion after the Oriental fashion, and a harem with eunuchs was maintained at his huge Apulian Castle at Lucera.

Among the numerous tributes to the memory of this gifted pioneer is the pronouncement of Cresswell Shearer, in his *Renaissance of Architecture in Southern Italy*, that to the Emperor "belongs the credit of being the first in modern times to attempt the establishment of a civilization based on rational principles. In important respects he forestalled our present-day culture. Mathematics, natural history and philosophy were

his favourite studies. His absorbing passion was falconry, and his book on this subject has long been recognized as the first zoölogical treatise written in the critical spirit of modern science. Next to falconry came his devotion to architecture, considered in his day as the practical application of geometry. Some three hundred years before the Italian Renaissance he was the first to revive sculpture and classical architecture."

Hitti rightly claims³ that Frederick's greatest single contribution to learning (often ignored by writers) was the founding of the University of Naples in A.D. 1224—the first in Europe to be definitely established by charter. He also considers the spirit of investigation, experimentation, and research which distinguished the court of Frederick as the commencement of the Italian *New Life*. Italian poetry was certainly first nurtured by Frederick's entourage—the Emperor himself being something of a poet. Music and letters also began to blossom in Sicily, largely under Arabic, Byzantine, and Provençal influences, while the output of both copied and original manuscripts of Sicilian and Italian origin on many subjects became abundant.

Although it was not until the works of Dante (1265–1321)—especially his *Divine Comedy*, together with the labors of Petrarch and Boccaccio—appeared that the Tuscan tongue was definitely established as *the* Italian language; yet several well-known poems were previously written in the vernacular Tuscan by poets attached to Frederick's court. This fact inclines certain authorities to bracket the Emperor's name with that of Petrarch as the *fontes verae et origines* of the *lingua italiana*.

The dicta of the late Professor Charles H. Haskins, undoubtedly the best recent judge of Frederick's literary qualifications, may be accepted. He says: "The reign of the Em-

³ Philip K. Hitti, *History of the Arabs* (Macmillan, 1917).

peror Frederick II holds an important place in the transition from medieval to modern culture. Much has been written of the cosmopolitan, intellectual life of his court, of its school of poetry, as the cradle of Italian vernacular literature and of the philosophers who linked it with the older world. To many it has seemed that under Frederick, 'the first modern man upon a throne,' rather than in the days of Petrarch, the real beginning of the Italian Renaissance is to be sought."⁴

Law and medicine, especially the latter, also felt not only his reviving but his greatly improving influences. He regulated the ancient school of medicine at Salerno and, among other reforms, initiated a registration of physicians.

Perhaps Erik Nordenskiöld furnishes the best (brief) review of Frederick's chief activities: "Italian in his upbringing, half oriental in his habits and mode of thinking, he gathered around him learned men from the East and West. He had Aristotle's writings translated from the Greek into Latin. Frederick's treatise on falconry is far more than a dissertation on hunting; in a lengthy introduction he gives an account of the anatomy of birds, in which he not only displays a knowledge of Aristotle's anatomical works but is also able to point out inaccuracies in his statements; further, he describes avian habits, the excursions of migratory birds, etc.

"The translation of Aristotle's biological and zoölogical treatises, that Frederick caused the learned Michael Scotus to make for him, was, perhaps, the most enduring of his reformatory aims, being, in fact, the work upon which the scientists of the later Middle Ages in general based their studies."⁵

Unfortunately Frederick lived during the period of ecclesiastic reaction in the thirteenth

century, and after his death his priestly opponents eradicated most of the cultural as well as much of the material progress he had achieved; for example, the dissection of human bodies was again prohibited and physicians were obliged, as before the Emperor's time, to rely for their human anatomy and physiology on classical traditions.

We can readily understand the hostility of the dominant church toward an Emperor who was at best only a lukewarm adherent of the Roman faith. With considerable truth he had been called the "baptized Sultan of Sicily," for in his official life and personal habits he was half-Oriental—kept a harem and supported dancing girls imported from the Orient. Moreover, he consorted with Arab and Hebrew philosophers from Baghdad and Syria, whose flowing robes and long beards were a familiar sight at his court.

Frederick II further maintained close relations with the world of Islam and Jewry by commercial and other transactions, discussing with these Oriental scholars numerous religious dogmas, mathematical problems, astronomical puzzles, geographical and cartographical queries, and astrological questions, to the neglect of Christian solutions of these enigmas, many of which he openly declared to be unsatisfactory. He was, in fact, a rationalist philosopher, as free of fanaticism and prejudice as it was possible for any man to be who breathed continually the all-pervading philosophic air of the thirteenth century.

Frederick was not only learned in all the departments of systematic medieval ornithology but also a good general zoölogist. Mention is often made of his portable menagerie, which formed part of his personal equipment. This collection was increased in size and variety from time to time as opportunity occurred. Imitating a practice observed in Egypt, he experimented with eggs to test the statement that they could be incubated by means of the sun's rays alone. He received

⁴ "The *De Arte Venandi* of the Emperor Frederick II," *English Historical Review*, July 1921.

⁵ Erik Nordenskiöld, *The History of Biology* (see the Bibliography).

from one of the Sultans a wonderful planetarium, showing the combined motions of the sun and moon, and sent in return a white bear and an albino peacock.

At the same time a nephew of the celebrated Salah-ad-Din, the Sultan Al-Kamil Muhammad, presented the Emperor with a giraffe, which, with other occupants of his traveling menagerie, accompanied him all over Europe. The sight of this fabled, long-necked beast astonished the good people of Italy and Germany quite as much as Frederick's return donation of the white bear and the albino peacock amazed and delighted the inhabitants of Damascus.

Undoubtedly the best reviews of falconry under the Emperor Frederick II are to be found in the erudite essays of the late Charles H. Haskins. His paper in the *English Historical Review* (July 1921) leaves little to add as a preface, and we make no apology for a wide use of it in this translation.

He opens the discussion by drawing attention to the strange omission from previous accounts of the Emperor's extraordinary activity of body and mind shown in his principal literary product, the *De Arte Venandi cum Avibus*. Even Hampe⁶ devotes only two pages to this monograph, the greater part of which he had not read.

Haskins furnishes an outline of the requirements for a complete text of Frederick's magnum opus: The whole manuscript should be carefully examined not only by a zoölogist but also by a falconer in relation both to its forerunners and to our present knowledge of practical and theoretical ornithology. Even after observing these essential preliminaries it will be difficult to assign the work to its final place, chiefly because the medieval portion of the literature of the subjects mentioned has been as yet insufficiently examined. In a footnote Haskins tells us that the principal study

⁶ Karl Hampe, *Kaiser Friedrich II in der Auffassungen der Nachwelt* (1925).

of this material has been made by Werth in his *Altfranzösische Jagdlehrbücher* contributed to the *Zeitschrift für romanische Philologie*, XII (1888), pp. 146-91 and 281-415, also XIII (1889), pp. 103-4, but without throwing any new light on the work of Frederick; and the German scholar entirely overlooks the Vatican manuscript of the *De Arte Venandi*.

The manuscripts which form the chief basis of the present translation are in six books, there being two distinct editions of the work—a two-book edition (which appears in both written and printed states), and the six-book edition known only in manuscript. For a more detailed record we refer the reader to our account in the section, "Manuscripts and Editions of the *De Arte Venandi cum Avibus*," which follows.

It is quite clearly established not only that Frederick wrote the *De Arte* with his own hand or by direct dictation but also that, as he himself tells us, it belongs more especially to the mature years of his reign and was written after thirty years of preparation for the task. In 1241 he was still gathering material for this chef-d'œuvre. The work can therefore be assigned chiefly to the years between 1244 and 1250, probably nearer the later date because of its unfinished character and the revision required and given it by Manfred after his father's death. Baron Pichon does not think that Manfred ever revised the remaining four books of the complete edition. On the other hand, all extant two-book scripts and prints may properly be called the Manfred Edition.

Haskins thinks that if the marginal colored figures found in the Vatican Codex were added chiefly under King Manfred's supervision, the original plan, *qua* illustrations of the text, was conceived by the Emperor; perhaps the actual work of the artists—the composition and drawing indicate the employment of more than one illustrator—was carried on

with the collaboration of both the King and the Emperor. It must not be forgotten that, as Haskins and Shearer both point out, Frederick was himself something of a draftsman and with his own hands had designed the celebrated towers of Capua. He was in consequence well equipped to supervise, draw, and color the two-book miniatures. While authorities differ as to the artistic merits of the larger figures (the seated portraits of the Emperor and King Manfred), there is no doubt about the zoölogical value of the avian figures.

The imperial author, in writing and compiling the *De Arte Venandi*, utilized several sources of knowledge, among them works on natural history, treatises on falconry, and, last but not least, his own observations, experiments, and personal inquiries. The most important literary source available for his purposes (in the twelfth and thirteenth centuries) was Aristotle's nineteen books on animal life, his *De Animalibus Historia*, his *De Partibus Animalium*, and his *De Generatione Animalium*. Frederick's references to zoölogical authority are almost entirely confined to Aristotle, whom he generally mentions by name.

He quotes Pliny once and only once. He also refers to the eyes of birds from a *Liber Animalium*, which was probably Avicenna's commentary on Aristotle, as the quotation does not occur in the latter's works but is found in the Canon, *Oculi sunt instrumenta visus, de quibus quare sint duo, quare in prora capitis locati, et quare altius instrumentis aliorum sensuum, et quomodo constant ex tribus humoribus septem tunicis dictum est in libro animalium* (Bologna MS., fol. 19, col. 1, ll. 43-47).

In one passage he cites the Aphorisms of Hippocrates. In another is a citation of the pseudo-Aristotelian *Mechanica* (Bologna MS., fol. 22, col. 2, ll. 7-11), which, as it happens, had hitherto been noted neither in Me-

dieval Latin, nor in an Arabic version of that work. It is likely that it was the translations from the Arabic of these treatises made by Michael Scot⁷ for the Emperor that the latter had read and from time to time consulted.

In passing, it may be said that Frederick's account of avian migration, mostly based on his personal observations of bird flight, is much more ample and satisfactory than that furnished by Aristotle. A number of passages in the *De Arte* could be quoted where the author, while aware of Aristotle's views on certain subjects, is not in agreement with them. The Emperor respects the Macedonian as a learned literary man but thinks he relies too much on hearsay and tradition and had little practical experience with birds—especially with birds of prey. This critical attitude is one that Frederick habitually assumed and maintained toward "all things in heaven and earth, both gods and men," and it may be traced in all the transactions of his short life.

Some of the influences of his crusade in 1238 are discernible in the pages of the *De Arte*. He brought with him from Syria and Arabia expert falconers and their hawks and spent many of his leisure hours in learning from them the secrets of their form of falconry—a sport that he regarded as the most worthy and noblest of all outdoor recreations.

A brief, introductory summary of the main subjects treated in and illustrated by the outstanding first two books of the *De Arte* now seems to be in order.

The hawks chiefly used by imperial followers of falconry were the gerfalcon, saker, peregrine, lanner, goshawk, and sparrow hawk. Frederick was acquainted with the employment of other birds for sporting purposes, but he regarded the foregoing list as comprising the most practical and valuable for his purposes. The eagle, for example, is

⁷ A copy of Scot's translation of Avicenna's *De Animalibus* is preserved in the Library of the University of Michigan.

too heavy to be carried about on the fist, and consequently is valueless in hunting other birds.⁸

The description given by Frederick of the capture of hawks for training purposes is very brief. He merely states that they are taken in nets—which sounds as if he intended to speak more fully on the subject in another chapter. As soon as it is taken, the captive, he says, should be put in a “sock” or enveloped in a linen bandage, then treated like an eyas.

The experiments of Frederick and the advice dependent on his experiences read about as one finds them in modern books on falconry. Falcon eggs, hatched under hens, as well as eyases taken very early from the nest, produce birds of little value as hunters. They should be left in the nest as long as possible. The parent birds are always the best trainers of young falcons as future sporting material. During the training and manning period, they should be well fed; otherwise the health of the feathers will suffer from “hunger traces.” Eyases should be given food twice a day (morning and evening). During the first stage of their education they must be allowed complete liberty within doors; but, meantime, nobody should be allowed near them except their keeper. When fully grown they are taken (in the evening) by candlelight to have the needle points of their talons coped, their jesses and bells attached, and their eyes seeled (*de ciliatione seu bluitione ipsorum*), as described in Book II, chapters xxxvii and xlvi.

The Emperor writes at length on the furniture and other devices employed in training the hunting falcon. These, as at present, include leash, jesses, bell, and swivel (*de longa, de jactis, de campanella et de tornetto*); and they are described in about the same terms as

⁸ Thuanus (see the Annotated Bibliography, below) divides the birds commonly used by medieval falconers into two classes, long-winged hawks-of-the-lure (*Loraria seu Pinnariae*) and short-winged hawks-of-the-fist (*Pugilares*).

one finds in modern textbooks. The bell, however, was sometimes attached, not to the bird's leg, but to one or more caudal feathers, the quills of which had to be perforated for the purpose; the Emperor (Book II, chapter xli) is opposed to the latter practice.

He also mentions the (now obsolete) drawer (*tiratorium*), the creance, and the lure and tells how to prepare them for actual use, also the drum (for “raising” wild fowl) and the “dead lure,” made from the skin of a crane, heron, or hare.

If we judge from early pictures, the short leash, now used with the goshawk and other small hawks, was not employed by most medieval falconers; and this explains why it is not described in the Emperor's otherwise finished list of hawk's furniture and apparel.

The falconer's bag (*bursa seu carneria*) is employed to carry the lure and the hawk's food. It is attached to his belt (*ad cingulum*). The falconer's glove (*chirotheca*) should be of large size—*amplum ut cito posset indui et exui*—and of thick leather (*de corio grosso*).

The Emperor describes three forms of the hawk's perch: the *high perch* (*pertica alta*), placed in a chamber of the mews but well out from the wall; the *low perch* (*pertica ima*), high enough, however, to prevent the bird's tail feathers from touching or rubbing on the floor or ground; and the *block* (*sedile*), made of either wood or stone in the form of a pyramid. Upon the (outdoor) block hawk hawks were placed; the high roost was used for, or intended to accommodate indoors, mostly seeled birds.

As the illustrations indicate, and since he has failed to describe it, the Emperor does not appear to have been acquainted with the screen or curtain, of canvas or similar material, attached to the high perch—an important adjunct which in a modern equipment of the hawk's house hangs from the whole length of the perch—to enable the bird to regain her stance by climbing on it back to

the roost after "bating" or flying from the perch; otherwise she would be left helplessly dangling in the air. He does, however, allot considerable space to the means taken to prevent a falcon from twisting her leash around the perch.

In taming and training hunting birds, both seeling and the hood (*capellum*), for completely or partially blinding the captives, are uniformly adopted, although there are falconers who, following an ancient practice, deal only with fully sighted birds. Frederick says that the seeling of hawks is a recent and cruel device, while, as for the employment of the hood (or cowl), he much prefers it as being effective and more humane than ciliation. He claims that it was he who, in imitation of Oriental falconers, first introduced the hood into Europe (*vide* Book II, chapter lxxvii).

The Emperor discusses the proper method of carrying the hawk on the fist, i.e., by holding the jesses (or short leash) between the fingers, exactly as is done at the present day, but he disagrees with those who direct that the bird be carried always on the same hand. He believes (Book II, chapter xlii) that it is better to hold the falcon sometimes on one fist, sometimes on the other, according to the direction of the wind.

After the jesses are in place, the recently caught falcon should be carried around almost continuously and without being fed, for twenty-four hours. Then the bird, fatigued by this exhausting treatment and more or less tamed thereby, is given a cold ration (*tiratorium*) in the shape of a fowl's leg.

The first lesson in training is to teach the bird to jump to the falconer's fist. When this is accomplished, and when the captive is no longer alarmed by the approach of its keeper and has grown accustomed to the noise made by men and domestic animals, it is gradually unseeled, as fully explained in Book II, chapter lxxviii.

A favorite prescription of the Emperor for

quieting restless falcons is to sprinkle them frequently with pure cold water, by spraying them with mouthfuls of fluid; but the falconer's mouth must be carefully cleansed before the operation. This use of the cold douche has been continued by falconers to the present day.

When fully tamed, the bird is carried outdoors to the fields, first on foot and eventually on horseback. Meticulous directions are given by our author as to the proper time and manner in which these directions are to be carried out; indeed much space is given to the conduct of the falconer in all his relations with the hunting birds in his charge.

Frederick regarded the office of falconer as important, one not to be lightly undertaken, because its duties are manifold and exacting and call for rare qualities of body and mind.

The final four books of the *De Arte* are replete with many interesting items touching the generalized experiences of the author, though few personal or particular references are given. Indeed these sections throw additional light on the modern, up-to-date qualities of Frederick's scientific mentality. Though the plan of the four books is elaborate and scholarly in its subdivisions—*divisivus et inquisitivus*—they are always practical, the result of the writer's own experience and observation; there is little speculation, and very little verbal digression. Nor is he dogmatic in expressing his opinion; whether he approves or disapproves, he gives his reasons for his conclusions. For example, in discussing (Book III) the use of the various kinds of lures he gives his preference to the form fashioned with crane's wings, but he mentions also the use of doves in Arabia, of hens in Spain, and of a pig covered with hare's skin in the "Island of Armenia." Falconers afield in England do not shout (as in Italy) when using the lure. The Emperor asked the reason for this silence, but got no explanation except that of "ancient custom."

Haskins ends his valuable and extensive review of the four books with quotations from a surviving fragment of a register (*vide* Böhmer-Ficker, *Regesta Imperii*, Nos. 2857, 3082) for a few months of 1239-40, several of which we believe worthy of repeating. In this diary forty entries are made concerning falcons, mentioning by name fifty of Frederick's falconers, including Master Walter Anglicus and his famous son, William. "Thus in November he [Frederick] writes from Lodi to his superintendent of buildings in Sicily thanking him for information about the haunts and nests of herons which the Emperor longs to see for himself. From Cremona he sends to his falconer Enzo for a report on his falcons, how many there are and in what condition, especially about those captured in Malta and touching the wild ones taken during the season. He orders another assistant to await him with hawks at Pisa, while he sends to Apulia for two hawks just brought by the emissaries of Michael Komnenos. After Christmas he sends for two sacred falcons—the one called 'Saxo' and another good bird."

Although in Book IV of the *De Arte* he remarks that winter is not a good season for hunting cranes, the Emperor writes in January to his falconer, Sardus, from Gubbio (in the modern province of Perugia), that he is capturing many fat cranes whose legs he is preserving for him. He adds that the falconer should come at once to take part in that noblest of sports, the hunting of cranes with gerfalcons, which Frederick describes at length in his fourth book. Shortly after, he sends dogs and falcons back to the south (where, in March, he trains additional birds) and gives further orders for the payment of wages and the assignment of equipment to his falconers. In February he concerns himself with the moulting of his falcons, distributing them during this trying period among his barons. In May we find the Emperor in

the Capitanata, whence he dispatches nineteen falconers to Malta for birds. When he needs live cranes for training falcons he orders the justiciars of Terra di Lavoro, Bari, and the Capitanata to have as many caught as possible and to send them for distribution among the royal residences.

The foregoing record is a mere fraction of Frederick's ceaseless activities. They are, as Haskins says, only glimpses of the Emperor's daily occupations and show his passion for falconry, pursued in the midst even of urgent concerns of state, not merely at intervals of relaxation. They illustrate the devotion of the ideal falconer, who is represented in the *De Arte* as desiring, first of all, not so much fame nor a plentiful supply of food for the table, but to own the best of hunting birds. The successful falconer, says Frederick, cannot be careless nor lazy, because his art demands much study and much labor. It is with pride in his mastery of this sport in its higher aspects and not as a mere boast that he says, in the preface to his monograph, *nos semper dileximus et exercuimus*.

At the risk of multiplying needlessly the encomiums bestowed upon the *De Arte Venandi* as a complete work on medieval falconry and ornithology, one must cite the commentary of George Sarton (*Introduction to the History of Science*, Vol. II, pp. 575-79). Sarton says, in part: "The text as compiled by Frederick himself seems to have been already completed by 1248, when it was lost in a defeat he suffered before Parma. A revision of the first two books, prepared by his son Manfred (born *ca.* 1232; king of Sicily 1258-1266), is the main source of the printed editions. It was translated into French before the end of the century. The complete treatise is very large; 589 pages in the Mazarine manuscript. The work is based on Aristotle, but also to a large extent on Oriental examples [observed by the author himself in the Far East, derived chiefly from Arabic books, or



PLATE 7.—Two specimens of the Augustales of Frederick II, gold coins struck at Brindisi and Messina after the year 1232. The upper coin is unique, both in design and in dimensions, since it is smaller in diameter and thicker than any other example known. Its weight is the same.

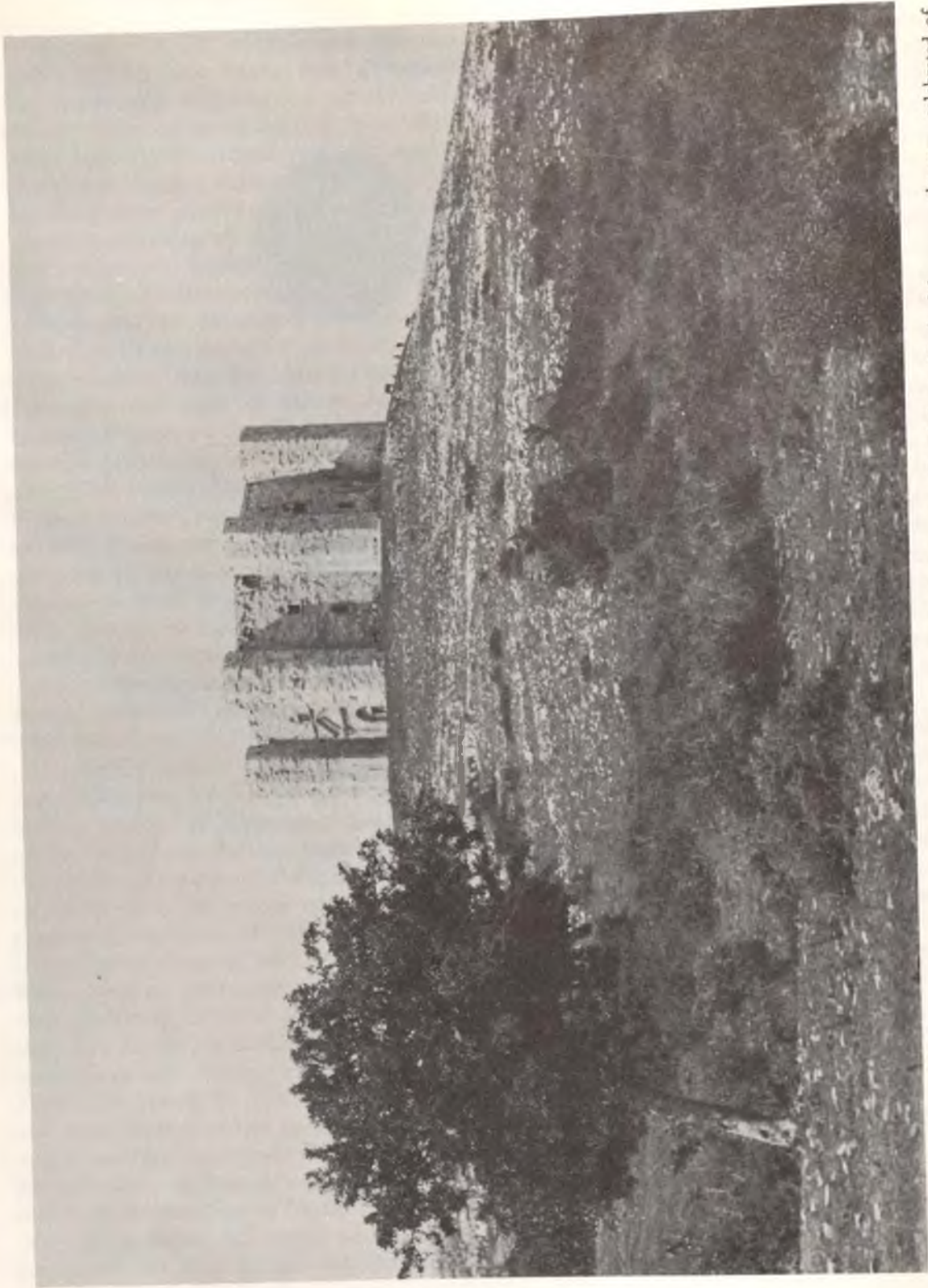

PLATE 8.—General view of Castel del Monte, Apulia, or, as it was known in Frederick's day, Castel Santa Maria del Monte, the most celebrated of all the Emperor's hunting seats. It is built on a height of the Murge Hills, some nine miles from the nearest town of Andria, in a particularly lonely situation. Until a few years ago, in the almost total absence of a proper roadway for wheeled traffic, it was a very arduous excursion to visit the castle.

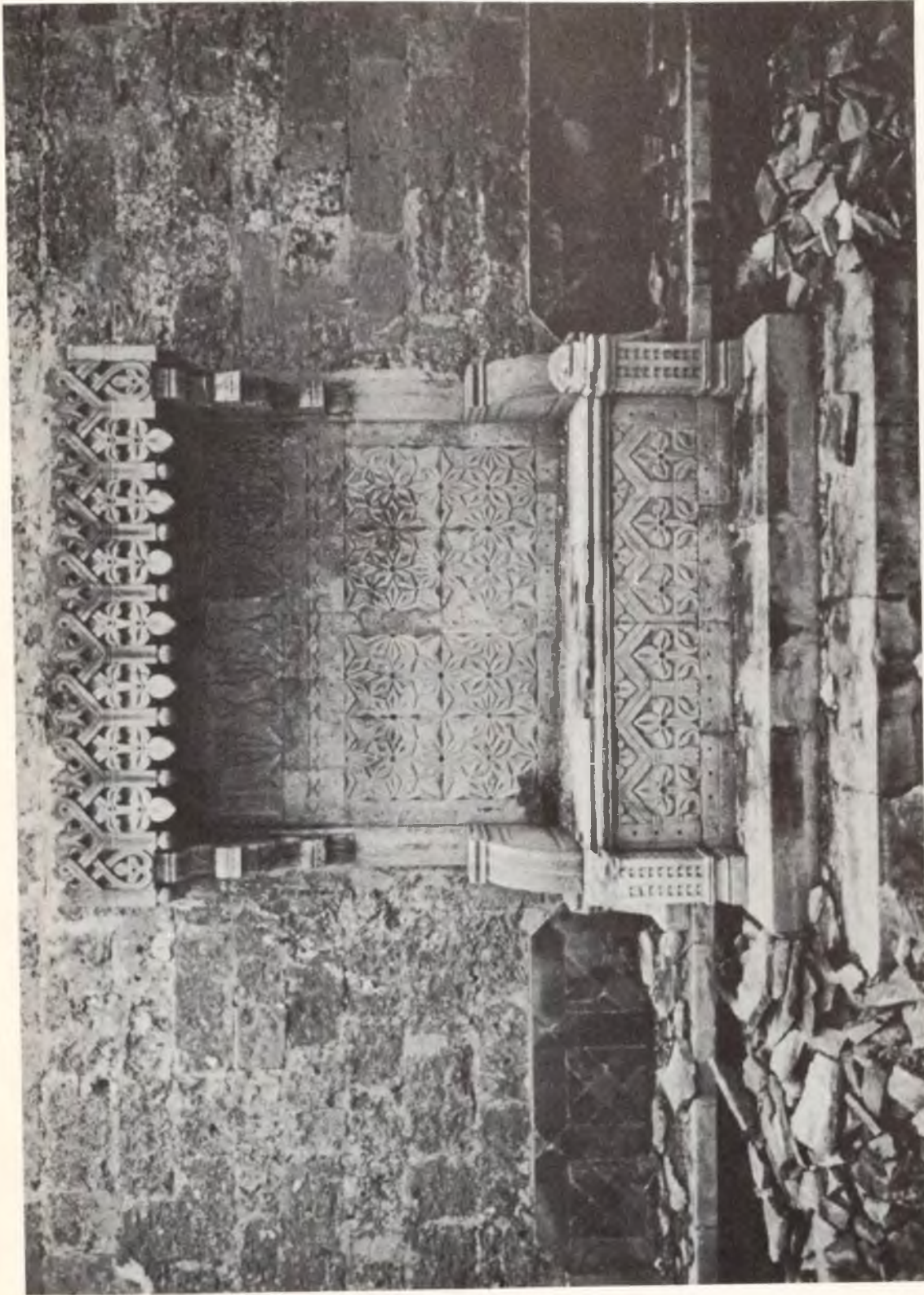

PLATE 9.—The Emperor's throne from the Audience Chamber of Castel Gioja del Colle, showing remarkable Sassanid patterns on the front. There is a row of Iceland falcons carved high on the back.

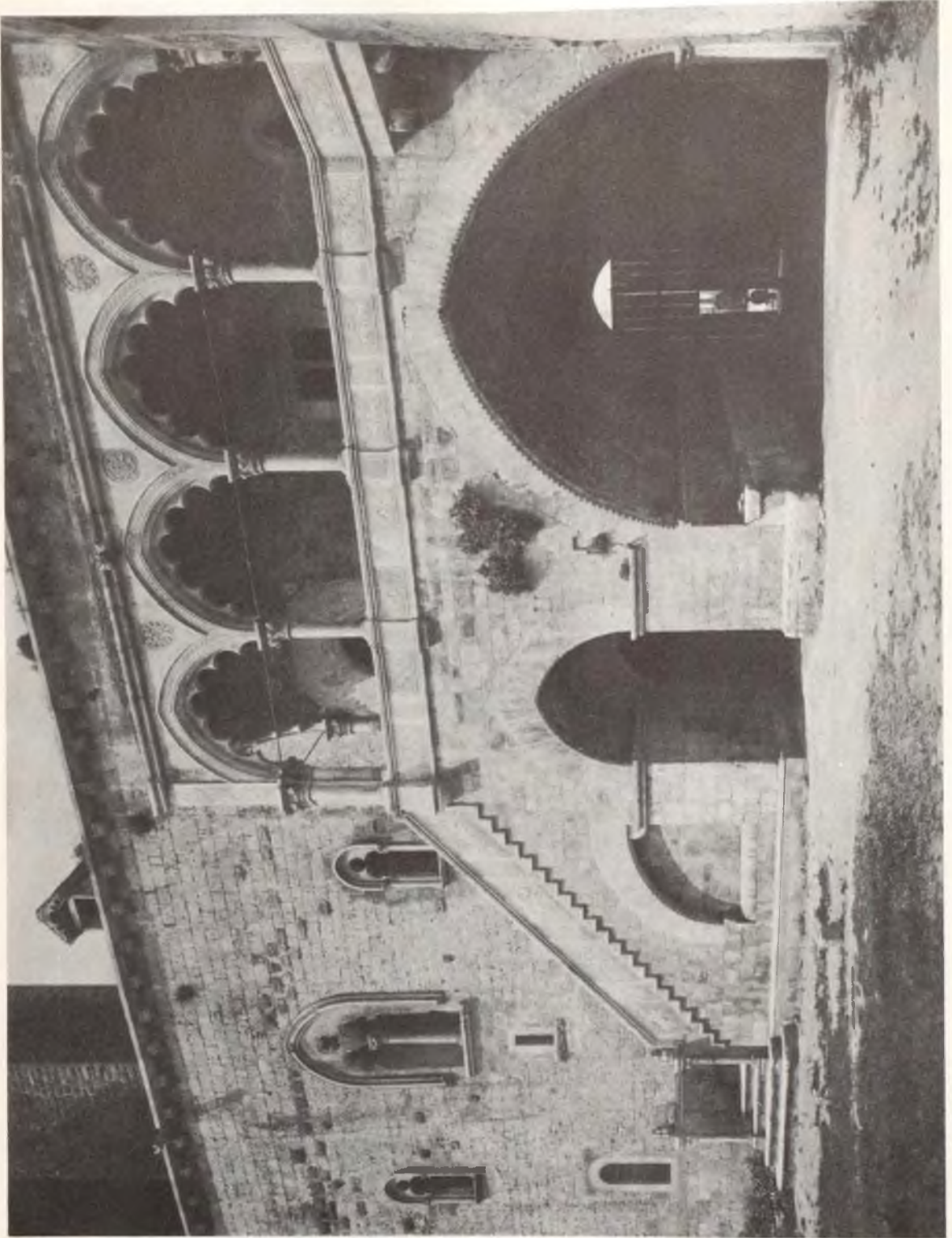

PLATE 10.—Loggia in the courtyard of Gioja del Colle near Bari. Freely restored.

obtained from Muslim falconers brought with him to Italy.] The monograph is very methodical and technical, the work of a man of science and a sportsman. It is divided into *six books* as follows: (I). Praise of falconry, zoological introduction, anatomy and habits of birds, and especially of birds of prey. (II). Rearing, feeding and seeling of falcons; necessary falconry implements, including hoods. (III). Various kinds of lures and their use, training of dogs for hunting with falcons. (IV). Hunting of cranes with gerfalcons; habits of cranes and gerfalcons; comparison of gerfalcons with other falcons. (V). Hunting of herons with the sacred falcon. (VI). Hunting of water birds with the peregrine falcon. Book I contains a number of facts on the anatomy of birds which had not been previously recorded, i.e. pneumaticity of the bones; the form of the sternum, structure of the lungs and of the rump glands. Remarks on the mechanical conditions of flight and on bird migrations were quite new. Frederick observed, imitated and improved the Arabian practice of equipping birds with hoods (Book II, chapter lxxvii). He made experiments on the artificial incubation of eggs, and to decide whether vultures find their food by sight or by smell. Much of this research work reveals a scientific spirit of the first order. His traveling menagerie included elephants, dromedaries, camels, panthers, lions, leopards, gerfalcons, white falcons, bearded owls and monkeys—even a giraffe, the first to appear in Europe. Frederick's genuine love of science is further revealed by the questions which he submitted to Michael Scot and Ibn Sab'in. He also loved to explode superstitions by means of experiments or by an exhibition and application of simple common sense, e.g., with regard to the generation of the bernacle geese. He tried to put a stop to the madness of the Crusades and to reconcile Christendom and Islām."

Frederick's treatise on falconry was in-

tended to be entirely scientific and general; hence we find him discussing few dramatic details, telling no hunting stories, and making few references to living men or to places. If he made any exception to this rule it was in favor of his beloved Apulia (in southeastern Italy), where, in maturer years and in company with his favorite and then full-grown son Manfred, he probably wrote most of the *De Arte*. There, in magnificent hunting lodges, he kept many of his falcons and made most of his experiments—he tells us that pelicans were called *cofani* in Apulia.

He makes at least one definite reference to his Apulian estates where his favorite castles were built. One of these had a tower built as a mews without lower windows, so as to make it semidark for falcons: *In quadam regione Apulie plane que dicitur Capitanata in tempore reditus gruum capte sunt, etc.*

Only a deep and wide examination of Arabian scientific literature can afford more than conjectures about its effect on the beliefs and philosophy of Frederick, especially upon his conception of science in general.

He followed Idrisi's geographic divisions into climates, the third, fourth, fifth, and sixth of which (corresponding mostly to our subarctic temperate and subtropical regions) he calls *nostræ regione*. Mention is made of *Britannia que vocatur Anglia*; and in speaking of the home of the gerfalcon, he says it is situated between Norway and Greenland: *in quadam insula que est inter Norvegiam et Gallandiam et vocatur theutonice Yslandia [Iceland] et latine interpretatur contrata seu regio glaciei*. The seasons he fixes by the transit of the sun through the zodiac. His knowledge of mathematics was almost profound; at any rate he understood the nature of tangents and the figure *quam geometre dicunt pyramidalem*.

Haskins maintains that "his terminology and arrangement, as in the introductory matter and the prologue to the second book, show

training in the philosophical methods of the age. *Legitur in pluribus libris philosophorum*, we read at the beginning of Chapter 2, Book II, on the relative size of male and female birds of prey, but his discussions of humours and complexions show the influence is not merely, as Niese [*Historische Zeitschrift*, CVIII, 510] says, of physiognomic writers but of the whole physiological tradition of the period."

Reference has already been made to the chapters of Albertus Magnus on falcons, hawks, and sparrow hawks appended to the *De Arte Venandi cum Avibus* in the Vatican manuscript and in both printed editions of the two-book series by Marcus Velsler and Schneider.⁹ The present translators regard these as an unwarranted, indeed a meddling, addition of unknown date. Haskins and other learned commentators fail to criticize or to attempt to explain its insertion. Although probably both the Emperor and King Manfred were acquainted with the writings of Albertus Magnus, they do not quote him; and while the latter naturalist refers to Frederick's status as a falconer, it is unlikely that he ever saw the *De Arte* manuscript. The fact is that the learned Count von Bollstadt (neither a good falconer nor a practical naturalist) during his voluntary retirement (in a Dominican monastery at Cologne) from his Episcopal See of Regensburg decide to write a commentary on Albertus Magnus. The result was incorporated in the Vatican manuscript. So far as their value in falconry and medieval ornithology is concerned they are inferior in all respects to the writings of both Manfred and Frederick. At best, the Albertus Magnus section can be regarded only as a contemporary description of certain birds of prey and their employment in falconry of which probably Frederick took little or no

⁹ These chapters are entitled: "Albertus Magnus *De Falconibus, Asturibus, Accipitribus, ex libro ejus XXIII, De Animalibus.*"

notice and from the publication of which he certainly benefited not at all; indeed, Harting¹⁰ regards the work as a crude compilation from various sources, which shows the author to have been imperfectly acquainted with his subject.

It is highly probable—there being no evidence otherwise—that the Bollstadt matter was added to the *De Arte* books by some scribe or other opportunist without the knowledge or consent of either King or Emperor. It was an unpardonable act, although doubtless well-intended.

Frederick has no good word to say about existing treatises on the noble art of falconry. He stigmatizes them as incorrect and badly written (*mendaces et insufficienter compositos*) and as discussing only small portions of the subject (*particule aliquot*).

Haskins has made a doubtful list of the authors probably available to Frederick. He says: "this earlier literature in Latin and the Romance vernaculars is known to us only in fragmentary and confused form: the letters to Ptolemy and Theodosius, the book of the enigmatical King Dancus, the puzzling references made by Frederick's contemporaries, Albertus Magnus and Daude de Pradas, to King Roger's falconer, William, and to 'the book of King Henry of England.'"

"It is sufficient for us to point out that Frederick draws little or nothing from the known works of these authors, all of them brief and confined to a summary account of the various species of hawks and falcons and to precepts respecting their training and diseases. Even King Roger's falconer, whom Albertus Magnus quotes through the intermediary of Frederick, is not mentioned in the manuscripts of the *De Arte* so far examined. All these writers might have been useful, primarily in relation to the treatment of [avian] diseases, but that part of Frederick's

¹⁰ James Edmund Harting, *Bibliotheca Accipitraria* (London, 1891).

monograph, if ever written, has not so far been discovered."

In addition to importing expert falconers from the Orient, Frederick also had their writings translated for his personal use. The most important of these works is that of the Arab falconer, Moamyn, entitled *De Scientia Venandi per Aves*. It was translated by the Emperor's interpreter, Theodore, and edited by Frederick himself (1240-41) during the siege of Faenza, near Bologna. In the preface to this work the Arabic author maintains that hunting is the only distinctive recreation and amusement: *In quantum enim sunt reges non habent propriam delectationem nisi venationem*.

Moamyn's popular treatise, of which many copies and editions have survived, is divided into five books—the first three devoted to birds of prey, in most part to their diseases and to the treatment of the same in the shape of prescriptions—so that the contents of the work have little in common with the *De Arte Venandi*.

Another monograph of the same character—of Persian origin, the Arabic version dated *ca.* A.D. 1200—is the book of Yatrib (Gatriph or Tarif), which was translated at the same time as the Moamyn work and probably as the result also of the Emperor's interest in it. It contains seventy-five chapters. The author preferred as a hunter the sparrow hawk; but this manual does not appear to have been utilized by Frederick.

Not only did the Emperor keep watch of his Saracen falconers, but he tested their methods and in some instances improved on them. As Haskins notes, he applied this same spirit of investigation to many questions in ornithology—for instance, to the nests of vultures and cuckoos, to the intelligence of cranes and ducks, and to the popular fable of the hatching of barnacle geese from trees or barnacles. He said that this last-named legend originated in the ignorance of writers about the

nesting places of the geese, which were always remote and hidden from the average observer, and from their never having seen the eggs, nests, or fledglings of these water birds.

Indeed the Emperor was that *avis rarissima* of the thirteenth century, a man who insisted upon seeing and hearing for himself. Quoting chapter and verse, Haskins notes that he investigated legends by demanding and sending for the evidence, favorable and unfavorable, respecting any theory or hypothesis. He brought up children in isolation to test the faculty of speech, and he cut open men to observe the process of digestion. If facts were not available, he drew no certain conclusions. Thus *fides enim certa non provenit ex auditu*.

Summing up what he has already said, Haskins remarks that although a keen sportsman the Emperor was not the man to lose himself wholly in the mere joy of falconry. His mind required that he be kept busy, his questions answered, and his knowledge not only extended but put in order.

It is true that the lessons taught in the *De Arte (scientia huius libri)* are essential for the falconer; but the monograph is, as we have shown and as the reader will discover for himself, much more than a mere manual of practical instruction.

The translators are deeply indebted not only to their eminent collaborators but to numerous other friends, among them: Sir Lynden Macassey, London; Dr. Arnold Klebs, Nyon, Switzerland; Dr. Gerhard Lomer, Director of Libraries, McGill University, and his assistants; Dr. A. E. H. Swaen, University of Amsterdam; His Eminence Cardinal Tisserant (formerly Librarian of the Vatican Library) and his assistants; His Eminence Cardinal Mercati, former Prefect of the Vatican Library; Dom A. M. Albareda, Prefect of the Vatican Library; Professor Jean Strohl, University of Zürich; Mr. T. A. M. Jack,

Editor of the *Falconer*; Professor Kenneth Scott, Western Reserve University; Dr. Gordon Washburn, Director of the Buffalo Fine Arts Academy; Mr. Don MacKinnon, Toronto, Canada; Mr. F. C. Sawyer, Librarian of the British Museum (Natural History); Mr. S. Wood, Library Assistant, Royal College of Surgeons; Mr. H. R. Ivor, Erindale, Ontario, Canada; Professor Dr. Felix Peeters, University of Brussels; the Directorate of the *Deutscher Falkenorden*; Alan Wood, Toronto, Canada; Dr. W. Hoffmann, Librarian, Württembergische Staatsbibliothek, Stuttgart; Mlle Braunstein, of the Société des Amis de la Bibliothèque Nationale, Paris; M. Jean Lailier, Conservateur de la Bibliothèque Mazarine, Paris; Dr. Christ, Curator of the Manuscript Division, Preussische Staatsbibliothek; Dr. Holter, Curator of Manuscripts, National Bibliothek, Vienna; Dr. Erwin, of the Munzkabinet, Kunsthistorische Sammlungen, Vienna; Mr. Sheridan Talbot, American Consul, Valencia, Spain; Monsignore Pelser, Vatican Library; Mr. J. W. M. van der Wall, Wasenaar, Holland; Dr. Max Meyerhof, Cairo, Egypt; Dr. Lynn Thorn-dike, Columbia University; Mr. Alfred B. Maclay, New York City; Dr. R. M. Bond, Santa Barbara, California; and Dom A. Wil-mart, Vatican Library. For many of the excellent photographs of the Vatican, Bologna, and Bibliothèque Nationale manuscripts we are indebted to Miss Adele Kibre.

Had it not been for the encouragement of the late Professor Charles H. Haskins of Harvard this work never would have been undertaken and the translators wish to acknowledge their gratitude and indebtedness to him for permission to make extensive use of his studies on Frederick II and the *De Arte Venandi cum Avibus*.

We wish also to thank Dr. George Sarton

and the Carnegie Institution for their permission to quote from the *Introduction to the History of Science*, and Mrs. Gertrude Slaughter and the Macmillan Company for consenting to the use of a passage from the illuminating account given of the Emperor and his work in *The Amazing Frederic*. And to Alfred A. Knopf, Inc., we are grateful for permission to quote from L. B. Eyre's translation of *The History of Biology* by Erik Nordenskiöld.

And, finally, the junior translator wishes to express her very deep appreciation of and gratitude for the valuable assistance rendered so freely and patiently by the staff of the Stanford University Press in the preparation of this volume.

While this translation does not attempt to cover every form of reference to falconry, and merely lists in the Annotated Bibliography most of the collections of poems on the subject, yet very little poetry relating to falconry has been quoted. At this point we include one example of such verse:

*A Lady Laments for Her Lost Lover, by
Similitude of a Falcon*¹¹

Alas for me, who love a falcon well!
So well I loved him, I was nearly dead:
Ever at my low call he bent his head,
And ate of mine, not much, but all that fell.
Now he has fled, how high I cannot tell,
Much higher now than ever he has fled,
And is in a fair garden housed and fed.
Another lady, alas! shall love him well.
Oh, my own falcon whom I taught and rear'd!
Sweet bells of shining gold I gave to thee
That in the chase thou shouldst not be afraid.
Now thou hast risen like the risen sea,
Broken thy jesses loose, and disappear'd,
As soon as thou wast skilled in falconry.

¹¹ Thirteenth-century sonnet by an unknown poet, translated by Dante Gabriel Rossetti.



Manuscripts & Editions
of the
"De Arte Venandi
cum Avibus"

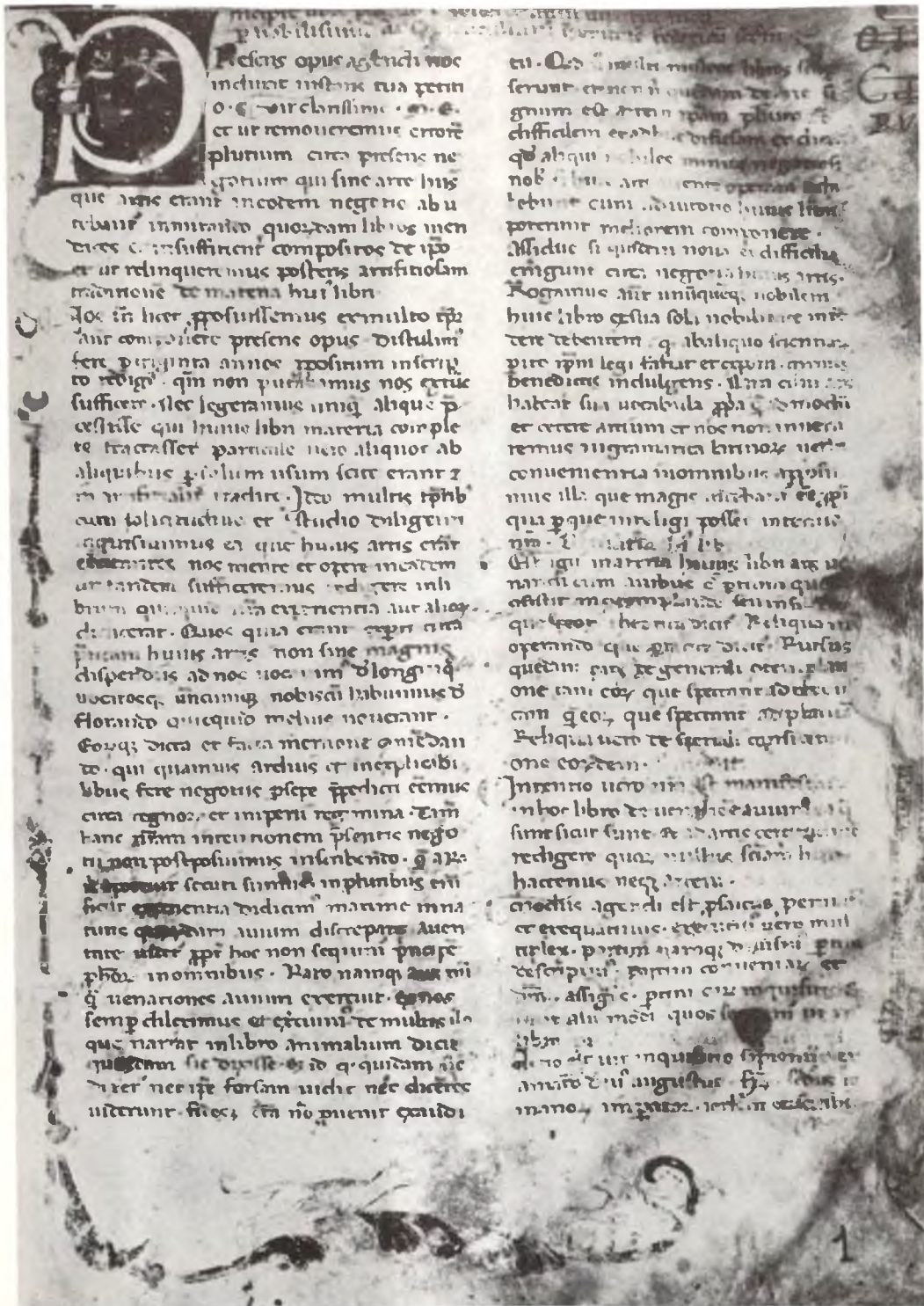

PLATE 11.—Incipit from the Bologna Codex, MS. Lat. 419 (717), of the *De Arte Venandi cum Avibus*



PLATE 12.—Incipit from the Mazarine MS. 3716 of the *De Arte Venandi cum Avibus*. Above is shown the royal falconer mounted and followed by hunting-dogs, and below the arms of the House of Anjou-Sicily.

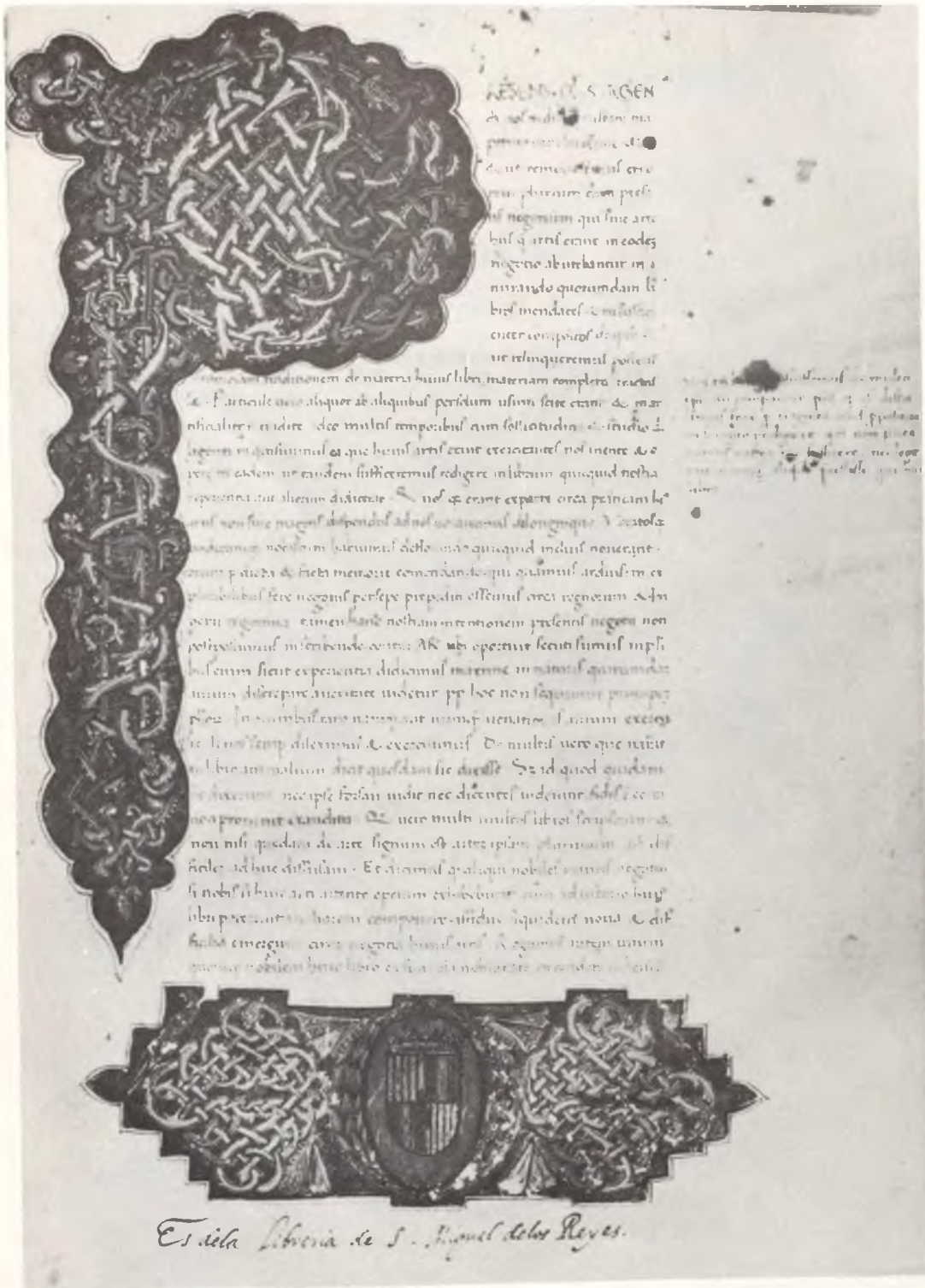

PLATE 13.—Incipit from the Valencia MS. 402 (fifteenth century) of the *De Arte Venandi cum Avibus*. Note the elaborate illumination and the coat of arms of the House of Aragon-Sicily.



PLATE 14.—Lower section of the first folio of the Vatican MS. Pal. Lat. 1071, of the *De Arte Venandi cum Avibus*. Authorities differ as to whether or not this picture properly represents the Emperor. It is reminiscent of the figure of Virgil shown on the frontispiece of Simon Martin's Ambrosiana manuscript. Compare with Plate 4, p. xxxii.

MANUSCRIPTS AND EDITIONS OF THE *DE ARTE VENANDI CUM AVIBUS*

HASKINS¹ and other authorities have pointed out that the manuscripts and prints of the *De Arte Venandi cum Avibus* of Frederick II of Hohenstaufen fall into two main groups, and can be bibliographically and conveniently catalogued in that manner. Reversing the order in which it is customary to list them (for reasons which will later appear), we catalogue, first, those manuscripts that belong to the six-book version, then the codices and prints of the two-book form.

I

SIX-BOOK MANUSCRIPTS

1. Bologna, University Library, MS. Lat. 419 (717)
2. Paris, Bibliothèque Mazarine, MS. 3716
3. Nantes, Musée Dobrée, MS. 19
4. Valencia, University Library, MS. 402
5. Rennes, Bibliothèque de Rennes, MS. 227
6. Oxford, Bodleian Library, MS. Digby 152

II

TWO-BOOK MANUSCRIPTS

7. Rome, Vatican Library, MS. Pal. Lat. 1071

¹ Charles H. Haskins, "The '*De Arte Venandi cum Avibus*' of the Emperor Frederick II," *English Historical Review*, July 1921, pp. 334-55. This is undoubtedly the best review of our present topic; it should be consulted by all students of Frederick II.

8. Vienna, National Bibliothek, MS. 10948
9. Paris, Bibliothèque Nationale, MS. Fr. 12400
10. Geneva, University Library, MS. Fr. (Petau) 170
11. Stuttgart, Württembergische Landesbibliothek, Codex H.B. XI 34-a
12. Paris, Bibliothèque Nationale, MS. Fr. 1296

PRINTED TEXTS

13. Velsler edition (Latin), Augsburg, 1596
14. Pacius translation (German), Onolzbach, 1756
15. Johann Gottlieb Schneider edition (Latin), Leipzig, 1788-89
16. Schöpffer translation (father and son), (German), Berlin, 1896

1. Bologna, University Library, MS. Lat. 419 (717), parchment, 144 folios (numbered at some late date), 200 x 270 mm. in two columns of 47 lines each. Thirteenth century, with red and blue initials throughout. There are unnumbered chapter headings. Each of the two prologues and the six books begins with a miniature initial. The upper edges of the pages have been slightly trimmed. Above the two columns of the first page is written the heading: *Incipit libri prologus de venatione avium rapacium facti per nobilissimum ac sapientissimum imperatorem Federicum secundum*. The first column begins with the words, *Presens opus agendi nos*

induxit instans tua petitio, Vir clarissime M. E.—a dedication to which further reference will be made in this discussion. The last three pages of this manuscript contain prescriptions for the treatment of maladies of horses, and were inscribed in a hand of a date later than that of the work itself. The book is bound in parchment of the eighteenth century, and was formerly in the library of Count Cornelius Pepoli, who acquired it (according to a letter of a friend bound in the book) toward the end of that period.

The eight illuminations that introduce the prologues and the books proper are appropriate to the subject matter. On folio 1 the letter *P* carries a miniature of a kingly figure in a green tunic and red mantle. He is pictured on horseback, carrying a falcon on his fist. The grotesque scroll, which extends to the bottom of the page, includes a running greyhound in pursuit of a stag. On folio 2^v there is depicted a second mounted figure of a king. The initial of the preface to Book II, an *O* (fol. 35), bears a small, regal bust-portrait. The scroll of this page embodies the figure of an archer aiming at a bird in flight. The verso of folio 35 has, at the beginning of Book II, the design of a falconer feeding a falcon. The initial of Book III (fol. 70) shows the figure of a falconer bearing a hawk. He wears a close-fitting cap with a chin strap similar to those worn by the falconers in the illustrations of the Vatican Codex (No. 7 on our list). Book IV, on hunting cranes with the gerfalcon, begins appropriately with a miniature representing a falcon seizing a crane. At the beginning of Book V (fol. 107) we are shown a falcon mounting in pursuit of a heron. The last illustration, the somewhat larger miniature of Book VI (fol. 125^v), repeats the motif of a mounted king carrying a falcon, this time beside a stream from which ducks are rising. We shall have more to say later concerning this manuscript, when we shall also discuss the script or scripts. The

work closes with the words, *Explicit liber cum quibus venantur.*

2. Paris, Bibliothèque Mazarine, MS. 3716. Latin. Early fifteenth century, parchment, 589 pages, quarto, single column. The work is introduced with the words: *Presens opus agendi nos induxit instans tua petitio, vir clarissime M. S.* The explicit is the same as that of the Bologna Codex. The manuscript is well preserved and is written in a fine humanistic Italian hand of the early fifteenth century.

Besides the beautifully foliated and floriated scrolls at the beginning of each chapter (to which are added on page 1 the figures of cherubim playing musical instruments), there are seven finely executed, miniature initials illuminating the manuscript. On page 1, a mounted falconer, carrying his hunting bird on his left hand, is accompanied by two hounds. At the bottom of this page, in the center between the foliations, there is a quartered coat of arms, surmounted by the crest of Anjou-Sicily and held by a couchant, helmeted lamb. The helmet is crowned with plumes, from which rises a cupid drawing his bow. Placed on either side of the cupid are large initials, *G* and *V*. The miniature on page 7 consists of a charming landscape depicting a watercourse on which, in the foreground, ducks are resting. In the distance rises a castle-crowned hill, while overhead falcons are flying. At the beginning of Book II (p. 140) there is a full bust of a man carrying a falcon. Book III has (p. 281) an initial letter *I* illuminated with a second bust of a falconer and his bird. The initial of Book IV (p. 355) presents a second landscape, showing a stream, a grove of trees, and a castle. By the water a crane is standing, with its beak pointed upward at a falcon descending. At the beginning of Book V (p. 432) there is a third water scene, wherein are shown a heron and a falcon in deadly combat. Finally, in Book VI (p. 517) there is still another view

of the stream and castle, this time with ducks both on the water and rising from it, while a falcon is poised overhead.

This volume was given to the Mazarine Library by the antiquarian Leblond, who acquired it about the year 1789. Of its earlier history we have no record.

Upon careful comparison with the Bologna manuscript (No. 1, above) there is no doubt in our minds that, although it may not be a direct copy from that work, it is very closely related to it. One need go no further than the prologue to be convinced of the common origin of the two manuscripts. In column 2 of folio 1 of the Bologna Codex we find the passage: *est igitur materia hujus libri ars venandi cum avibus cujus partium quedam consistet in contemplando seu in si . . . o que theorica dicitur, reliqua in operando que practica dicitur*. Three or four letters have been blotted out by stains on the vellum. In the Mazarine text the words *seu insi* come at the beginning of the last line of page 2. The scribe has left the remainder of the line blank, beginning anew, at the top of page 3 (after a short space left free for a word or two), with the words *que theorica dicitur*. And on folio 7^r of the Bologna manuscript the second from the last paragraph ends abruptly: *alie vero confuse et sine ordine, modo sole, modo cum aliis, ut*; then begins a new paragraph: *Loca vero adque exeunt sunt diversa*. In the Mazarine text, on page 31 there is a break after *ut* and then, without beginning a new paragraph or sentence, come the words *loca vero*, etc. Numerous examples of this sort could be cited; a few will be mentioned when discussing other copies of the manuscript; but an examination of the two texts reveals no material differences that cannot be accounted for as scribal errors or emendations.

It is strange, however, that no one has recorded the fact that in Book V of the Mazarine text the pages have been placed

out of order, probably when the work was last bound. To make confusion worse confounded, the pagination is of a date later than that of the binding. The pages, after 482, should be read in the following order: 487, 488, 485, 486, 483, 484, 493, 494, 491, 492, 489, 490, 495, 496, etc. Another unrecorded peculiarity of this manuscript is that in Book VI there are long passages missing. On page 541, before the paragraph at the bottom of the page that begins *Sequitur dicere*, there is missing a passage that is found in the Bologna manuscript (from fol. 130, col. 1, l. 19, to fol. 130^v, col. 2, l. 29). And in similar fashion there are all the following lacunae: page 546 (Bologna MS., fol. 132, col. 1, l. 42, to fol. 132^v, col. 1, l. 30); page 552 (Bologna MS., fol. 133^v, col. 1, l. 20, to fol. 134, col. 2, l. 16); page 559 (Bologna MS., fol. 135^v, col. 1, l. 15, to fol. 135^v, col. 2, l. 23); page 560 (Bologna MS., fol. 136, col. 1, l. 23, to fol. 136, col. 2, l. 5); page 565 (Bologna MS., fol. 137, col. 1, l. 25, to fol. 137, col. 2, l. 16); page 567 (Bologna MS., fol. 137^v, col. 1, l. 40, to fol. 137^v, col. 2, l. 34); and on page 575 (Bologna MS., fol. 139^v, col. 2, l. 39, to fol. 140^v, col. 2, l. 20). In addition to these passages there is a break in the context of the Mazarine manuscript after page 572, which ends with the words *in aliquo non falconibus novitiis*; at this point two folios are missing whose text can be found in the Bologna MS., from fol. 138^v, col. 1, l. 44, to fol. 139, col. 2, l. 34. This last lacuna can be accounted for by the simple loss of the folios; but the rest must be ascribed either to careless copying, which seems strange when one considers the careful work on the rest of the manuscript, or to the fact that the book was prepared from a manuscript from which a number of folios were missing. It is not a case of "lost" folios in the Mazarine Codex itself, since the lacunae all occur in the middle of the page. If this supposition is correct, then the Mazarine text

was not transcribed from any copy of the *De Arte* now known to exist.

3. Nantes, Musée Dobrée, MS. 19, fifteenth-century Italian, 280 x 195 mm., 275 pages on paper.² Bound in green morocco. Edges marbled and gilt. There are three guard pages, two of which are parchment.

This copy of the *De Arte Venandi cum Avibus* was purchased by Baron Jérôme Pichon in 1837 from the Florentine bookseller Molini, and it is his account of the manuscript, published in the *Bulletin du Bibliophile* (16^me Série, 1864, pp. 885-900), that furnishes most of the information we have regarding this work. Pichon compared his volume with that in the Mazarine Library, but the record of his findings is not sufficiently exact and detailed to permit us to establish its relationship to the Bologna Codex and others. For instance, Pichon's examination of the Mazarine Codex did not reveal the errors in binding nor the lacunae of Book VI.

Upon the death of the Baron his collection was sold, and on April 18, 1869, the manuscript was purchased by Giraud de Savine (for the sum of 1,550 francs) for Thomas Dobrée, a collector of Nantes, whose library passed to the Museum that now bears his name. Professor Haskins was unable to trace this valuable volume further than the sale to De Savine, and it was only through the kind assistance of the Office de Documentation of the Société des Amis de la Bibliothèque Nationale, in Paris, that we were able, in January 1940, to ascertain the existence and present whereabouts of the manuscript described by Pichon. It was then too late to arrange for it to be photographed, because it had been removed from the Museum and placed in safe keeping for the duration of the war.

Pichon tells us that this codex contains, also, the remedies for equine ailments found in the Bologna text, and, in addition, a Latin

² Pichon says 261 pages.

translation made for Frederick II of the treatise on falconry by the Arab Moamyn as well as a Latin translation of another treatise on falconry by a Persian author (G. Persicus). Pichon thinks this last individual may be Guillinus or Guicennas, who is mentioned by Tardif. The volume contains also a censored letter addressed to the Emperor Theodosius by the physician, Grisophe, on how to treat ailing falcons. The explicit reads: *Explicit hic liber, scriptor sit crimine liber.*

The first nine pages of the manuscript contain a table of contents, and a dedication reading as follows: *Cum preambulum ad omnia scibilia, summe necessarium est, Hestor et mi princeps tuis virtutibus merito deificande, hac enim ratione moveor presentem hanc tabulam huic tuo operi summopere delectabili inscribere, ut per ipssam valeas omnia in ipso contenta brevibus horis contemplari et reperire.*

The letter C of this dedication is highly ornamented and frames the portrait of a very young man wearing a red toque and a green costume. At the bottom of the same page, in the center of a green and gold wreath, and between two irons for the cauterizing of birds, set up as trophies, there is a portrait of a youth in a lilac robe wearing a toque of the same red as that of the young man. He is holding in his hand a green book and is evidently intended to represent its author, whereas the youth at the top of the page is the owner. Pichon informs us that these preliminary pages are indited in a hand similar to that of the corpus of the text but that it is not contemporaneous; neither the ink nor the paper is the same; moreover these pages are not impregnated with sandarac, as are those of the rest of the book. Finally, over the Prologue to the *De Arte* are written the words: *Ad divum Astorem Manfredum secundum Faventie dominum.*

Baron Pichon informs us that Astore Manfredi II was Lord of Faenza, jointly with his brother from 1417 until 1447, and alone

until his death in 1468. These dates coincide with the probable age of the manuscript; but the dedication, according to the account in the *Bibliophile*, is probably addressed to the grandson of Astore II, Astore III. The latter was assassinated by Cesare Borgia, who robbed him of his estates. This would account for the youth of the figure in the initial *C* and the terms of the dedication.

Frederick's prologue in this manuscript is addressed to *vir clarissime M. S.*, as is the Mazarine text. It is further pointed out that in the chapter on jesses, in the phrase, *ut quedam tricatura nodosa ex HAC autem formam replicationis sic venient ista due foramina intra sese*, etc., the word *HAC* (found in the Vatican MS.) is missing in both Pichon's manuscript and the Mazarine text. In both instances a blank space has been left. This same lacuna occurs in both the Valencia and the Rennes texts; but in the Bologna text there is no indication that anything is missing.

We shall show later that the Rennes text is a copy of the Mazarine volume and that the Valencia Codex is very closely related to the Bologna text. A close examination of the Dobrée manuscript might lead to further interesting information regarding the relationship of the different copies of the *De Arte Venandi*.

4. Valencia, University Library, MS. 402, parchment, 238 folios, 27 lines, single column, 329 x 211 mm.; early fifteenth century. Elaborately decorated initials in gold, blue, and red interlaced cords. At the bottom of the first page is the coat of arms of the House of Aragon-Sicily, the family descended from Manfred's daughter, Constance, through her marriage with Peter II of Aragon.

Of the history of this copy of the *De Arte* we know nothing, and it was only through the very great kindness of Mr. Sheridan Talbott, United States Consul at Valencia, that we were able, in 1940, to secure our

photographic reproduction of the manuscript at a time when the Spanish Civil War had made it impossible to buy in Valencia the materials necessary for the preparation of such a copy.

Blue and red capitals are used throughout the manuscript. In the dedication the second initial has been obliterated, and all that can be made out is *vir clarissime, M.*

A guard sheet carries the inscription (in an eighteenth-century hand): *Thoma de Capua liber de avibus et de arte aucupandi atque etiam de Theorica hujus artis*. Since Thomas of Capua was titular Cardinal of Santa Sabina (Rome) in 1212, Legate in Lombardy, and died in 1243, he was a contemporary of the Emperor; but one wonders what evidence led to the erroneous attribution of this work to him by the writer of the inscription. A note at the bottom of the page reads: *Es dela Libreria de S. Miguel delos Reyes*.

Careful examination of the Valencia text and comparison with the Bologna manuscript lead one to the conclusion that it is a copy of the older manuscript. There are none of the lacunae of the Mazarine text, and the only differences are of a minor nature and may be ascribed to scribal emendation. It must be noted that the order of two pairs of folios has been reversed in binding, viz., folios 214 and 215 and folios 219 and 220.

5. Rennes, Bibliothèque de Rennes, MS. 227, 404 numbered folios, written on paper in a cursive hand. It is without illustrations. The text runs from folio 1 to folio 387^v; then there is one blank folio followed by a table of contents covering fifteen pages. This table is in no way related to those of the two-book forms. The Rennes manuscript is a direct copy of the Mazarine text, since in Book V the scribe copied the pages that are out of order in the older manuscript without noticing any discrepancy. No breaks appear in the writing that would correspond with the interrupted argument of the text. The

parts that are missing from Book VI of the Mazarine copy are lacking here also, with the exception of that portion which corresponds with the two folios lost between pages 572 and 573 of the older manuscript. This passage is found in the Rennes text, beginning at the bottom of folio 373 and extending to the top of folio 376. There is, consequently, nothing to be learned from this manuscript that throws any light on the original form of the *De Arte Venandi cum Avibus*.

6. Oxford, Bodleian Library, MS. Digby 152, fourteenth century. This manuscript, as Haskins says, is the remnant of a treatise on falconry the third book of which dealt with (or probably borrowed from) the subject of Frederick's second book. At the beginning of the fourth book (all that remains), the author says: "we have related in our foregoing third book of this work the means by which birds of prey are captured. One method is by the use of nets, and another without them [i.e., from the nest]. And we have told how, once caught, they are to be fed and taught to stand on the fist; also how they are manned, both with and without the hood. We have shown how they are to be carried about, both on foot and on horseback, and how they are to be placed on the perch [also on the stool] and how they are to be taken up, etc." The author then continues: "In this our fourth book we relate how birds of prey are taught to leave the fist and are slipped to fly at quarry. And since falcons cannot accomplish the purpose of the chase without leaving the hand of the bearer, and yet may not be released from the fist to pursue the hunt unless they have previously been taught not to fly away from their master—that is, to be willing to wait for him, or else to return to him—it is necessary, first of all, to tell how they may become accustomed to do this, to which end, etc." There follow what are sometimes direct quotations from Frederick's Book III and at other times

simply summaries of his material. The fragment ends with the words: *Item aves cum quibus venari debemus ad hoc sunt boni necesse est ut habent potentiam et audaciam, ad hoc autem ut habent potentiam exigitur ut sint sani et bene tractati et ut habeant audaciam requiritur quod habeant voluntatem (habent autem) voluntatem non habebunt si male tractati sunt, quoniam ex . . .* (Digby 152, fol. 54^v). See the Bologna Codex, fol. 80^v, col. 2, and also Book III, chapter xix, third paragraph, of this translation.

We come now to the group of two-book manuscripts which contains the two most famous and beautiful codices of the imperial author's work, as well as others derived from them. Into this class fall also the various prints.

7. Rome, Vatican Library, MS. Pal. Lat. 1071, thirteenth century, parchment, 111 folios, 360 x 250 mm., inscribed in beautiful Italian Gothic, in two columns. A single hand probably wrote the entire manuscript with the exception of folio 74, which appears to us the work of a different scribe. To support this theory is the fact that folio 74 has been turned over in binding, so that its verso faces the verso of folio 73. The codex contains approximately 900 marginal illustrations, nearly all in color, of birds, animals, falconers, perches, and other falconry equipment. The chapters are rubricated, and the whole work is foliated, but by a later hand. As far as page 103 the leaves are paginated in Roman numerals.

The first folio of the manuscript is badly damaged, and the margins are torn. This makes it very difficult to read the dedication, but Haskins and others have deciphered it as follows: *Pre[sens opus ag]gredi nos induxit et insta[ns tua pe]titio, fili Karissi[me Man]fride*. Not only do water stains obscure the greater part of the text of the first and second pages, but there are two holes in the parchment that obliterate other portions. The

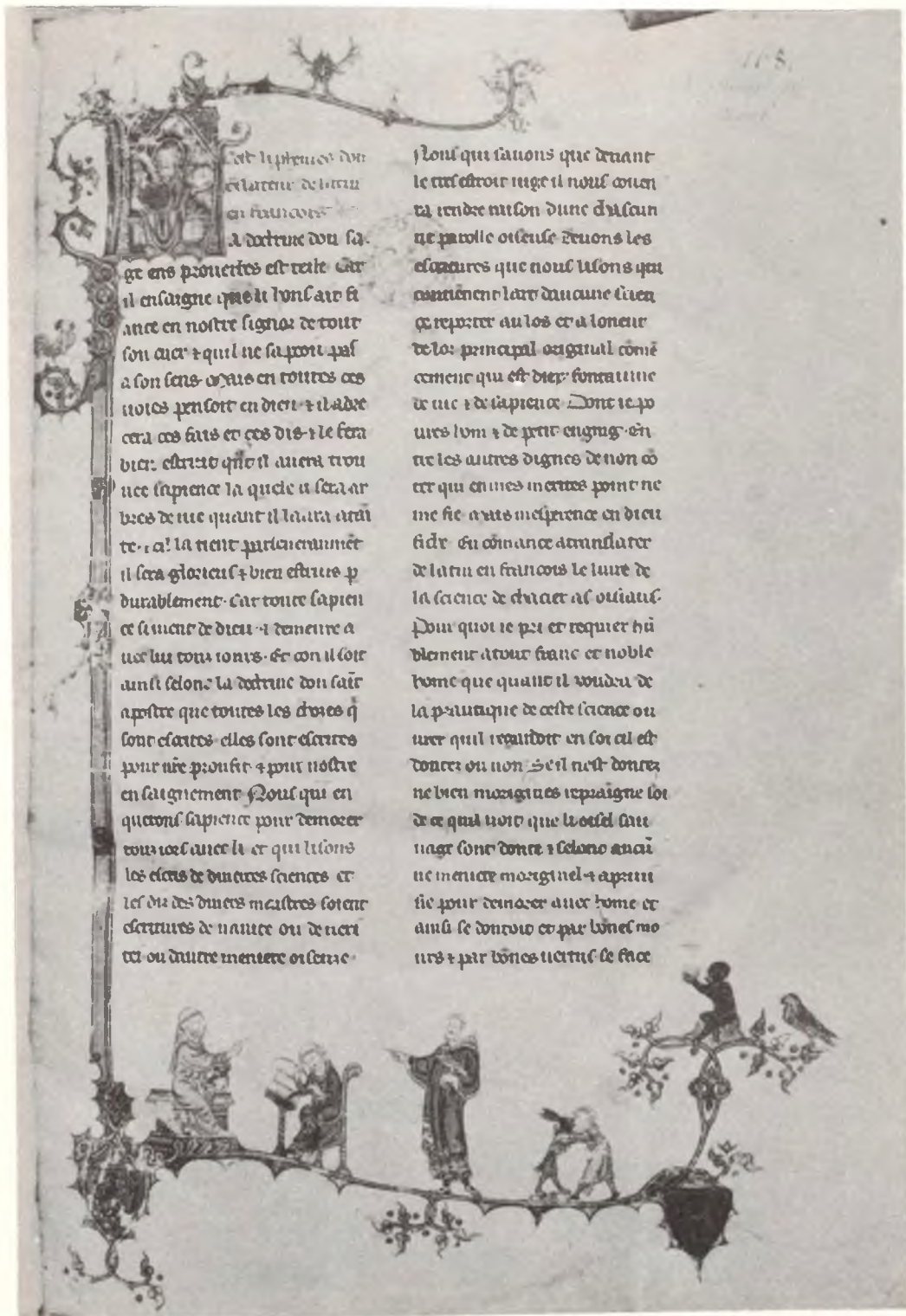

PLATE 15.—Folio 1 of the French translation of the *De Arte Venandi cum Avibus* in the Bibliothèque Nationale (MS. Fr. 12400), showing the illumination of the Translator's Prologue.



PLATE 16.—Incipit from the Geneva manuscript, Fr. (Petau) 170, fifteenth-century copy of the *De Arte Venandi cum Avibus*. (Photo by Molly.) Compare with Plate 17 opposite.



La doctrine du
 fructe es prouer
 bes est telle car
 l'en seigne a
 l'homme att fiance en
 nre seigneurie de tout
 son cuer et quil ne se
 cupisse pas a son sens
 Mais en toutes ses

loires pense a dieu et
 il adrefcra ses fais
 et ses bis et le fera bie
 instruit quant il a
 uia trouuee sapiee
 laquelle luy sera vnn
 arbre de vie quant il
 saura attante et sic
 la tient per fueram

PLATE 17.—Incipit from the Württembergische Landesbibliothek MS. (H.B. XI, 34-c).
 Late fifteenth-century copy of the French translation of the *De Arte Venandi
 cum Avibus*. To be compared with Plate 16.

RELIQVA
L. LIBRORVM
FRIDERICI II.
 IMPERATORIS,

De arte venandi cum avibus,
 CVM MANFREDI REGIS
 additionibus.

Ex membranis vetustis nunc primum edita.

ALBERTVS MAGNVS
 DE
 Falconibus, Asturibus, & Accipitribus.



AVGVSTÆ VINDELICORVM,
ad insigne pinus.

Apud Ioannem Prætorium,
 Anno M D XCVI.

Cum privilegio Cesaris perpetuo.

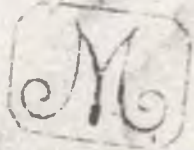

L.
DIVI AVGVSTI
FRIDERICI SECVNDI
 ROMANORVM IMP. HIERSA-
 SALEM ET SICILIAE
 REGIS,

De arte venandi cum avibus,
 Liber primus.

PROLOGVS PRIMI LIBRI,
quæ legi potuit.

.....
 & vt remoueremus errorem plurimum circa præ-
 sens negotium, qui sine arte habentes quæ artis
 erant, in eodem negotio . . . imitando
 quorundam libros mendaces & insufficienter
 compositos de ipso: & vt relinqueremus pos-
 teris artificiosam traditionem de materia hu-
 ius libri. Nos tamen, licet proposuissimus ex
 multo tempore componere præsens . . .
 vlimus fere per . . . propositum . . .
 . . . quoniam non putabamus nos ex tunc
 sufficere, neq; . . . quædam inquam
 quem præcelsisse qui huiusmodi materiam co-
 plere tentasset, particula vero iniquior ab ali-
 quibus per solum vsuta, sicut erant & martifi-
 cialiter tradita; Imò multis temporibus cum
 sollicitudine diligenter Inquisuimus ea quæ
 huius artis erant, exercitantes nos in ea . . .
 in eadem, vt tandem sufficeremus redigere in
 librum quicquid nostra experientia aut aliorum
 didi-

A

[LXVI]

PLATE 18.—Title page and page 1 of Marcus Velsler's edition of the
De Arte Venandi cum Avibus, 1596.



PLATE 18a.—Title page and page 1 of the German translation of Velser's edition of the *De Arte Venandi cum Avibus*, by Johann Erhard Pacius.



LIBRI TITVLVSTA

lis est.

Liber Diui Augusti Friderici Secundi
Romanorum Imperatoris Hierusalem et
Siciliae Regis. De Arte Venandi
cum Avibus.

Quod Ars Venandi cum Avibus Dignior est
caeteris Venationibus.

Cum autem Ars Venandi cum Avibus pars sit
artis venandi simpliciter: Et Ars venandi sim-
pliciter per vires alias partes habeat. Et cum omnes
partes artis venandi per Venationem deducantur
in Actum: Primo videndum est quid sit Ars
Venandi, et quid Venatio, et quae partes artis
Venandi, quatenus praetermissis alijs omnibus ad-
praesens. de sola arte Venandi cum Avibus sic di-
catur. Ars Venandi est collectio documentorum
quibus sciunt homines ad opus suum deprehen-
dere animalia non domestica, Vi, vel inqum o-
Venatio autem in se aucta est, quam motus aut
exercitium, quae eo studio fiunt ut huiusmodi
animalia capiuntur. Partium autem artis
Venandi, alia est, quae cum Interventibus Invenitur



PLATE 19.—Incipit from the Vienna Codex of the *De Arte Venandi cum Avibus*.

water stain has penetrated beyond the fortieth folio, but after the twentieth only small portions of the writing itself have been rendered illegible.

On the first page of the manuscript, below the text, there is depicted (in outline drawing and uncolored) a laurel-crowned figure (in profile) of a man seated and holding a falcon on his left fist. The right hand and index finger are extended toward a second man, who kneels before him, also carrying a falcon. As S. A. Luciani has pointed out in his most illuminating article³ on the *De Arte* manuscripts, the profile of the seated figure recalls that of the Emperor as represented on the augustals. The verso of the first folio is decorated with two crowned figures, the upper of which is evidently that of the Emperor. He is shown seated on a throne, robed in blue with a violet tunic and wearing a large yellow crown and a jeweled *loros*, which passes under his yellow girdle. At his feet a falcon rests upon a stool. In his right hand the Emperor holds a lily stalk with three flowers—probably a symbol of the orb. The lower figure (shown full-face, as is also the upper one) is that of a younger man who wears a red mantle and a blue tunic; he is crowned (with a less pretentious diadem) but wears the *loros* and girdle to denote his kingly state. He carries a scepter surmounted by a fleur-de-lis. At the feet of this second royal personage (who probably is Manfred, to whom the manuscript is dedicated) kneel two falconers carrying their charges. One of them has attached to his belt the wing of a fowl, to be used as a tiring, whereas the second attendant holds in his hand a chicken leg intended for the same purpose.

On folio 5^v there appears one more enthroned figure, uncrowned and wearing a close-fitting cap with a chin strap such as is worn by many of the falconers depicted in

the second book of the manuscript. This last personage bears a falcon, and is probably intended to represent Manfred in the role of falconer, since it appears on the page containing the first of several passages added by Frederick's son to the text of the *De Arte*. There are no other figures in the book that can be identified as portraits. The many falconers depicted in the second book may have been drawn from life, for certain types are continually recurring, but it is not possible to identify them in any way with known individuals.

It is, however, the remarkable execution of the drawings of bird life that renders this precious manuscript unique. To quote Haskins: "There are in all more than nine hundred figures of individual birds, not only falcons in various positions, with their attendants and the instruments of the art, but a great variety of other birds intended to illustrate the general matter of the first book. Brilliant in coloring, the work is accurate and minute, even to details of plumage, while the representation of birds in flight has an almost photographic quality which suggests similar subjects in modern Japanese art. Whatever degree of Saracenic influence the treatment may show, these illustrations rest upon a close and faithful study of bird life, and thus form an essential part of the work which they accompany."

As Gertrude Slaughter⁴ writes: "How fascinating are the sketches! He drew eagles, owls, storks, turtledoves, larks, parrots, pheasants, vultures, as well as pelicans, swans and every other waterbird. He drew them accurately, to illustrate the text, and also with artistic appreciation although they are only rough sketches [*sic*]. And he amused himself by putting in quite unnecessary scenes that enliven the whole thing and take the reader

³ *Archivio Storico per La Calabria e La Lucania*, Anno III, Fasc. II (Rome, 1933), pp. 153-78.

⁴ *The Amazing Frederic* (Macmillan, 1937), p. 291. Quoted by special permission of the Macmillan Company, publishers.

with him into the country. There is a fox watching birds, with a delightful expression of tail and countenance; there are men in boats hunting and fishing, with fish in the water beneath them. There is a boy who has left his red tunic on shore and is swimming through green waves, his white cap still on his head, and another boy climbing a tree for birds' eggs. There is even a picnic scene, with cooking going on over a fire."

While sharing Mrs. Slaughter's enthusiasm for these wonderful illustrations, it should be pointed out that Frederick himself could not have been their creator, since this manuscript was not in existence during his lifetime. Nor are her interpretations of the scenes depicted entirely correct. The first boat scene is intended as an illustration of the passage by King Manfred (Book I, chapter iv) in which he compares the legs of ducks to the oars of a galley; and the second drawing shows how a migrating bird takes refuge from a storm on the mast of a ship. The boy swimming across an unfordable body of water, after leaving his tunic on the shore, is going to the rescue of his falcon, who has brought down quarry on the far side. The boy (or man) climbing a tree is looking for falcon's nestlings, not eggs; and the picnic scene is an illustration of the manner in which a falconer makes a milk-and-egg mixture on which to feed his hunting birds. In fact, throughout the book the drawings and paintings are, without exception, illustrations of the text at the points at which they occur. There are in all 170 human figures, 915 birds (including falcons), 12 horses, 36 other animals, besides numerous fish in ponds, falcon's leashes, hoods, perches, baths, and other equipment clearly and exactly drawn; birds' nests are shown in trees and on crags and towers, as well as in the mews. As we have already indicated, there are depicted a rowboat, a sailing ship, a falconer swimming, and men preparing food and caring for the falcons in

various ways. The operations of seeling them, blunting their claws, feeding, bathing, and spraying them, placing them on and lifting them from their perches, and, finally, carrying them about on horseback are all exactly illustrated.

The task of illustrating the manuscript was never completed. The drawings on folios 94 to 100 inclusive have not been colored, and certain pages are left blank. The manuscript ends abruptly on folio 111^v, which is torn at the edge and badly stained. The last unfinished sentence reads: *Item si duobus falconibus quos contingit aliquando simul super unam manum portari . . .*

The Vatican Codex has bound with it Albertus Magnus' *De Falconibus, Asturibus, et Accipitribus*, an addition made, probably, during the years of its wanderings in Northern Europe.

The manuscript is the original of all others in the two-book group. The differences between it and those in the six-book class will be discussed later. Between 1290 and 1300, as we shall see, it was translated into the French of the period and its illustrations were copied by Simon d'Orleans for the Lord of Dampierre and his wife, a grandniece of Frederick's second wife. This fact indicates that the manuscript had been carried to northern France soon after Manfred's death in 1266. In 1596 the Codex was the property of the Very Learned Joachim Camerarius, Physician of the Republic of Nuremberg, who loaned it to Velsler (*q.v.*) to make the first printed edition, published at Augsburg. In the sixteenth century, also, a Latin manuscript copy (the Vienna MS.) was prepared. At about the turn of the century this Codex became a part of the Palatine Library at Heidelberg. In 1623 it was sent, with the rest of that collection, to the Vatican Library as the gift of the Elector of Bavaria, thus completing more than three hundred years of wandering.

8. Vienna, National Bibliothek, MS. 10948. A sixteenth-century copy, on paper, of the Vatican Codex, and the only other Latin manuscript in this group. It is a volume of 220 single-columned (23-24 lines) and numbered folios, 202 x 208 mm., in an embellished, cursive German hand. It is bound in parchment. The edges of both covers are tooled in a small gold-chain pattern with palm-leaf designs in each corner. The initials "P. E. F." adorn the center of the front cover. On the upper portion of the back are two labels. The upper one bears the partially erased inscription, *Imp. Friderici liber de Arte Venandi cum Avibus Cod. Mst. Philos Lat. No. (?)*, written in the hand of Lambecius, the Librarian of the Imperial Collection, indicating that the manuscript has been the property of that Library since the middle of the eighteenth century.

The heading of the manuscript reads: *Libri Titulis Talis est, Liber Divi Augusti Friderici Secundi Romanorum Imperatoris, Hierusalem et Siciliae Regis, De Arte Venandi cum Avibus, Quod ars venandi cum avibus dignior est caeteris venationibus*. The text proper begins with the phrase, *Cum autem ars venandi cum avibus pars sit artis venandi simpliciter*. In other words, this copy begins with folio 2 of the Vatican Codex, a circumstance which is probably due to the fact that a large part of its folio 1 was illegible even at that date. As further evidence of its close relationship to the Vatican copy, it must be noted that the first page of this manuscript bears a faithful and detailed reproduction of the two royal figures and the two falconers with their birds that illustrate folio 1^v of the original codex.

The Vienna copy of the *De Arte Venandi cum Avibus* is neither accurate nor complete. The end of Book I, chapter ix, after the passage *nec istud praedari de nocte faciunt pro eo quod sicut asserit Aristot. de nocte vident et de die non vident*, is omitted entirely. Al-

though the water stain obscures much of the page of the Vatican copy (fol. 10^v) containing this sentence, it is strange that the scribe made no attempt to reproduce the large portion which is legible. The same is true of a great part of the next chapter, which, in the Vatican Codex, is contained on folio 11. Sometimes a space is left; sometimes no indication is given of a lacuna. The long gap at the beginning of Book I, chapter xxiii, caused by the loss of several folios from the Vatican Codex, is not even indicated. Occasionally an attempt has been made to fill in missing words, but not always with success. Moreover, the scribe takes the liberty, now and then, of altering certain passages; e.g., the Vatican MS., fol. 110^v, reads *Omni etiam falconi qui portantur cum capello minus nocetur a vento quam sine capello. Hoc accidit quoniam omnia falco postquam impositum est sibi capellum distringit alas et plumas suas ad se ex qua districtione ventus minus potest sublevare falconem de super manum quando portatur*, whereas the Vienna MS. reads *et hoc accidit quoniam falco cum sibi impositum est capellum distringit alas et plumas suas ad se unde falconem minus sublevare potest ventus quando portatur super manum*. Other similar alterations of the text might be quoted, but to little purpose, since this manuscript is a copy of the Vatican Codex and it therefore can throw no light on the origins of the two-book group. It reveals nothing that cannot be discovered in the Vatican Codex itself concerning the Emperor's original plan for the *De Arte Venandi cum Avibus*.

9. Paris, Bibliothèque Nationale, MS. Fr. 12400. Parchment, 186 folios (13 x 9 inches) in two columns, with illustrations. This is a French translation made about 1300. It is written in a beautiful Gothic script, and begins with a "Translator's Introduction," commencing *La doctrine dou sage en proverbes est teile. Car il ensaigne que li hons ait fiance*

en notre signor de tout son cuer et quil ne saproit pas a son sens, mais en toutes ces vois pensoit en dieu, et il adrecera ces fais et ces dis, etc. Continuing, on folio 1^r, we find these words: *cest œuvre haute et grief a exposer ai je envaie se sachent tuit et entreprise a translate de latin en francois a la requeste et a la petition de tres noble baron mon dous signor jehan chevalier descendu de tres noble lignie nei de sante racine signor de dampierre et de st. disier et a la reverence de ma douce dame Ysabel dame de ces meismes leus descendue de tres hautes saintes lignie de roys et a lonor de tres noble damoiseil Guillaume lor fil et a la grace de tres noble damoiselle jehanne de Woingnouri, madame jone.*⁵ . . .

Baron Jerome Pichon, in his account of this manuscript, gives us the following information regarding its translator's patrons: Jean II, Lord of Dampierre, was a nephew of Guy de Dampierre, Count of Flanders. He died in November 1307. Isabeau de Brienne-Eu, his wife, was the daughter of Jean de Brienne and Beatrix of Chatillon. She was, thus, the grandniece of Yolanda of Brienne, also called Isabella, second wife of Frederick II, who died in 1228. Yolanda's brother, Alphonso, grandfather of Isabel of Dampierre, was Chamberlain of France and died in Tunis in 1270. He had been educated partly at the court of Frederick, and it is possible the Vatican manuscript fell into his hands at the death of Manfred and was sent by him to France.

In fixing the probable date of this translation, as Pichon points out, it is important

⁵ "It is my desire that all may know that this important work—a difficult one to expound—has been translated from Latin into French at the request and petition of the very noble baron, my gentle lord, John, Knight, descended from the very noble line of holy origin, the Lord of Dampierre and of St. Disier, and is dedicated also to the reverence of my sweet lady Ysabel, Mistress of the same domains and descended from the very high and holy line of kings, and to the honor of their son, William, the young nobleman, and to the grace of his wife, the noble lady Jeanne de Woingnouri."

to note that the "William" of the dedication must have been very young at the time, because he and his wife are given the titles *Damoisel* and *Damoiselle*, respectively, indicating that the young nobleman had not yet become a Chevalier. The dedication was written, therefore, in the early years of their marriage. Since their son (also Jean) was of an age to marry and to negotiate concerning the emoluments owing him, on the occasion of his wedding, by the inhabitants of Vignory in 1319, the marriage of his parents is placed by Baron Pichon as not later than 1295, perhaps even earlier. This fixes the date of the translation in the last ten years of the thirteenth century, but not later.

The last page of the manuscript is signed: *Simon d'orliens anlumineur d'or anlumina se livre si.*

Page 1 of the codex is illuminated with a miniatures letter *L*, depicting an enthroned, haloed figure, with the right hand raised in blessing and the left holding a large globe. At the bottom of the page a seated monk is shown, dictating to a scribe, who sits working at a desk, and beside whom there stands an elderly man carrying a falcon. His right hand, like that of the monk, is held out with pointed forefinger. These figures and that of the miniatures *L* are bound together by an illuminated scroll, to which are added other figures—a cock, a bat, two children, a rabbit, and a second falcon. Two identical shields form a part of the decoration at the bottom of the page. The shields are gold, with lion sable, charged with a lambel, i.e., the arms of the cadets of the House of Dampierre, which became possessed, through marriage, of the Countship of Flanders. The manuscript ends with these words: *ancor se de ii faucons les queilz il avenra aucune fois estre portes sus une main li i est perdu il sera plus tost racouvrez e ces chose soufisient qui sont dites du tirour du chapel e des autres chose en present.* This ending is sufficient evi-

dence that at the time the Vatican MS. was copied (in translation) the last pages were already missing. In its original state this fine codex had a ten-line explicit inscribed in red, which is now all but completely erased. The only legible words therein are the last, *Deo Gratias*. The signature we have already mentioned.

The "Author's Prologue" begins: *Tres chers fils Manfroi, ta requeste et ta petition*. This folio has an illuminated *T*, the vignette of which depicts an elderly king, bearing in his left hand a fleur-de-lis scepter, while his right hand and index finger are extended as if in admonition. He is seated on a bench against a scrolled background. Below, under a tent-like canopy, is seated a younger man (uncrowned) talking to a falcon on his fist; near him kneel three figures, two of whom also carry falcons. The style of these drawings is entirely different from the pictures of the Vatican miniatures. Folio 3 is illustrated by a group resembling the drawing on folio 1 of the Vatican manuscript—a crowned figure, carrying a scepter, enthroned beneath a baldachine, addressing two falconers (with birds) whose pose and equipment are identical with those of the original manuscript. But here again the style is that of the French artist.

Beginning with folio 6 of the French translation and folio 3^r of the Vatican manuscript, the illustrations representing birds are identical. At times it was necessary, owing to lack of space, for the artist to alter the order and arrangement of the bird figures; but close comparison of the two manuscripts shows that none of the drawings in the older work have been omitted by the copyist. Indeed, where certain figures in the original manuscript are obliterated by water stains and in the few cases where they are shown only in outline, the French artist has completed the drawings. He has even repeated some paintings and added others, such as the human-faced owl on folio 35^r. On folio 10, where the figure

of Manfred (Vatican folio 5^r) is reproduced, the young man is shown standing in half-profile, holding a falcon. Here again the style of dress is French. The rowboat at the bottom of this same page has acquired a sail and an additional passenger (a person of rank, perhaps Dampierre). The mast carries the Maltese cross and a pennant. On folio 28 of the translation (corresponding to the missing folios of the Vatican Codex, Book I, chapter xxiii) the translator omits the short opening of the chapter on the "Regions to which Birds Migrate," and has given instead a new heading, *Ci parolle des membres des oisiaux*, for the remainder of the matter contained in that chapter. This lacuna in the Vatican text seems to have been of an extremely early date.

The drawings of birds in this volume, although beautifully executed, are far less lifelike than those of the older manuscript. They have, none the less, drawn the favorable attention of a number of critics, notably G. Vitzthum, in *Die Pariser Miniaturmalerei des XIII Jahrhunderts* (Leipzig, 1907), pp. 228 f.

10. Geneva, University Library, MS. Fr. (Petau) 170. 152 folios; the first four, containing a table of contents, are missing. Two guard sheets at the beginning and end; 378 x 260 mm., written in two columns, bound in brown calf of the seventeenth century, marbled edges. Illustrated. This manuscript was once the property of Louis de Bruges, Seigneur de la Gruhuyse. It passed into the library of Louis XII of France, whose royal arms, bearing the fleur-de-lis, partially cover and replace the *ex-libris* of its first owner. On either side of Louis XII's shield are the floating ribbons of the original coat of arms bearing the words, *Plus est en vous*, flanked in turn by two mortars throwing bombs—further evidence of the Louis de Bruges ownership.

This is a copy of the French manuscript

in the Bibliothèque Nationale, but the illuminations and illustrations of the first folios of the latter codex have not been reproduced. The duck pond on folio 10 of this manuscript is the first illustration of the text and corresponds to the first drawing of wild life in the Vatican and Paris manuscripts (in each case a duck pond). From that point on, all the illustrations, with an important exception to be noted later, are copied from the Paris manuscript.

In this copy of the *De Arte* we encounter an inferior standard of execution and artistic achievement. The human figures, birds, and other animals are lifeless and poorly portrayed, and the coloring is inaccurate. There are also a few omissions, chiefly of those drawings where architectural features form a part of the illustration. A very important addition has, however, been made to the manuscript, viz., the frontispiece, the artistic execution and value of which are vastly superior to the illustrations of the textual corpus. It is the work of a Flemish artist, drawn with great vigor and good perspective. Hippolyte Aubert, in his account of the Petau collection of manuscripts in the Geneva Library,⁶ to which this codex belongs, remarks that the figures therein may be portraits. He points out, however, that the chief personage depicted is probably not intended to be Louis de Bruges, since it does not resemble the known portraits of that prince, but is, rather, an imaginary representation of the imperial author. This is the portrait of a prince seated in a large hall of typically Flemish architecture, surrounded by a dozen or more ladies and gentlemen, as well as by a number of falconers holding hawks and accompanied by dogs. The central picture is framed in a continuous landscape, which breaks up into a series of outdoor scenes in

⁶ *Notice sur les Manuscrits Petau conservés à la Bibliothèque de Genève* (Hippolyte Aubert, Paris, 1911).

which appear many and varied figures of both domestic and wild birds.⁷

In the middle of the eighteenth century, this volume was lent by its owner, Ami Lullin, to M. Huber-Alléon, who added to it the interleaved sketches that now form part of the volume, i.e., the head of a lion, a horse, and five hawks—one of them a hooded falcon.

11. Stuttgart, Württembergische Landesbibliothek, Codex H.B. XI 34-a. This manuscript forms the second part of a volume entitled *Französische Jagdschrift*, the first portion of which is composed of a copy of the work of Gaston Phebus, Comte de Foix, *Traité de Vénérie* (folios 3 to 98). The second part is entitled *Frederic II, Empereur d'Allemagne, Traité de la Science de Chasseur aux Oiseaux* (folios 99 to 297). Two folios are lost between those numbered 293 and 294; and at the end the work breaks off abruptly at a point near the conclusion of the last chapter. The whole manuscript (with the exception of folios 1, 2, 298, and 299, which are on paper and are a late addition) is executed on parchment (345 mm. x 245 mm.). Only folio 2^v has any inscription, and that is an "owner's mark." The binding of the volume is cardboard covered with brown leather. The back is of leather. The book has also a thick paper wrapper dating from the beginning of the nineteenth century.

The only illustrations in the volume are the two full-page miniature frontispieces. They are of special interest because they are evidently copies of the title pages in the two similar manuscripts of the Petau collection. Moreover, the chirographies of all four manuscripts resemble each other closely. There

⁷ A second book of the Petau collection (No. 169), *Le Livre de la Chasse* of Gaston Phebus, Comte de Foix, bears the same royal crest, the same erasures, ribbons, and mortars, and gives other evidence of identical provenance. The frontispiece, a hunting scene, is very similar in style to that of the manuscript in which we are interested, although it seems to us less well executed. This work will be referred to again in connection with the Stuttgart manuscript of the *De Arte Venandi*.

is no alteration in style, or in the poses of the figures in the Stuttgart volume, although the execution is somewhat stiffer and the proportions and perspective fall short of the excellence attained in the Geneva manuscripts. This is especially obvious when one compares the two *De Arte* frontispieces. When all these factors are taken into consideration, the four manuscripts appear to be the work of the same studio, or school, and to have been executed at about the same date.⁸

Clues to the original (still unidentified) owner of the Stuttgart volume are found in the shield on folio 3 and the initials "E. C." inscribed on the collar of the hound in the frontispiece (fol. 99). The book came later, as a gift, into the possession of Prince Karl von Loewenstein-Wertheim; for on the second folio we find the words, "A Charles, Prince de Loewenstein-Wertheim, Conte de Rochfort, 1744." A leather label attached to the back of the paper wrapper bears the letters, "MS LTUM DE VANAT. I. KARL F.Z.L.W." Dr. W. Hoffmann, Librarian of the Württemberg State Library, gives it as his opinion that the codex came to that institution as a gift from a member of the Loewenstein-Wertheim family to King Friedrich I of Württemberg about 1810.

12. Paris, Bibliothèque Nationale, MS. Fr. 1296. This is a (second) French translation of the second book of *De Arte Venandi cum Avibus*. It is entitled *Livre de l'instruction des Oiseaux de proie faucons, espreviens, laniers, autoirs et plusieurs autre*. This work contains, on folios 22^r to 24, the portion missing in the Vatican Codex between folios 58 and 59.⁹ If the translation was made from the Vatican Codex and is not a modernized copy of the Paris manuscript, then we must ascribe the loss of these folios from the origi-

⁸ In *Die Flämische Buchmalerei* (1925), pp. 137, 199, M. Winkler ascribes the illustrations of the Stuttgart volume to Master König-Edwards IV. This would place the date of the volume about 1479.

⁹ Book II, chapter xxxiii.

nal to a period after 1482 and before 1596, because the manuscript bears the signatures (on the last page) of Pierre II and Marie de Luxembourg, father and daughter, who died in 1482 and 1546, respectively.¹⁰ Furthermore the Velsler edition, which lacks the material contained in these folios, was published in 1596.

The first page of the present treatise bears the signature, *Jac. Aug. Thuani*, indicating the subsequent ownership of the volume by the celebrated historian and bibliophile, Jacques Auguste de Thou. Its possession by him is indicated also on page 458 of Volume II of the catalogue of his library, printed in 1664: *Instruction des Oiseaux de Proye de l'Empereur Frederic II, in folio*. The volume bears catalogue numbers Codex Colb. 2177¹¹ and Regius 7458.¹²

This rounds out the list of twelve manuscripts known at present to students of the *De Arte Venandi cum Avibus*. It is, perhaps, a complete one as far as the two-book edition is concerned. The earlier manuscripts of the six-book group had no remarkable illuminations or illustrations to attract the attention of students and were consequently not so well known. It seems to the present translators not beyond the realms of possibility that other early six-book codices of Frederick II's great work on falconry may be discovered in some of the smaller libraries in Italy or Spain.

Besides these manuscript copies of the *De Arte Venandi cum Avibus*, there are four printed texts, a copy of the first of which the translators have been fortunate enough to secure. As in the case of all the manuscripts (with the exception of the Dobrée manuscript in Nantes), we have photographic copies of the other prints.

¹⁰ See Pichon, *Bulletin du Bibliophile et du Bibliothécaire. Seizième Série* (Paris, J. Techener, 1864), p. 898.

¹¹ Colbert.

¹² Royal Library or (now) Bibliothèque Nationale.

13. The Velser edition (1596), entitled *Reliqua Librorum Friderici II, Imperatoris, De Arte Venandi cum Avibus cum Manfredi Regis Additionibus Ex Membranis vetustis nunc primum edita. Albertus Magnus de Falconibus Asturibus et Accipitribus, Augustae Vindelicorum ad insigne pinus. Apud Joannem Praetorium Anno MDXCVI, cum privilegio Caesaris perpetuo*. The title page has engraved in the center a pine tree and scroll bearing the words, *Honos Erit Huic quoque Pomo*. The work is dedicated to Ferdinand, son of Charles, Archduke of Austria (Hope of the Germans). In the dedication Johann Velser correctly ascribes the *De Arte* chiefly to Frederick II, son of Henry, grandson of Ahenobarbus (Barbarossa), and adds: *Manfredus enim filius post patris demum mortem, obstetricis in eo munere functus est*.

In the "Address to the Reader," Velser says that he received the autograph parchment manuscript from the Very Learned Joachim Camerarius, Physician of the Republic of Nuremberg. He tells us that the many lacunae in the text of this edition are due to defacement and age of the original text. The latter, he remarks, contains many illustrations of birds and other objects which cannot easily be reproduced; even if they could be reproduced, he fails to see what great value they would be to the reader. One illustration of a different nature he gives, viz., a young man of regal aspect, shown in a sitting posture. This portrait he believes to be that of Manfred, since the existing portraits of Frederick show him bearded. Following this introduction there is reproduced across two pages a woodblock print of the lower miniature of folio 1^v from the Vatican Codex.

This printed edition includes, also, an index with numbered chapters (supplied by Velser). Then follows the text of the first two books of the *De Arte*, in which the lacunae correspond exactly with the illegible portions of the Vatican Codex. There are

typographical errors and a few added words; yet, on the whole, the work is a faithful reproduction of the original text. Velser includes in this edition the *De Falconibus, Asturibus, Accipitribus, Ex libro ejus XXIII De Animalibus* of Albertus Magnus, with a numbered index of chapters, bound in with the Vatican manuscript of the *De Arte*. The volume closes with a poem in blank verse on three pages under the following heading: *Ne istae etiam vacarent pagellae, fabulam de initio rei accipitrariae, eleganter excogitatem, ex secundo libro Hierocosphiouy incerti auctoris, visum subjungere*.

14. Pacius, a German translation, Onolzbach, 1756. This is entitled: *Friederich des Zweiten, Romischen Kaisers übrige Stücke der Bücher von der Kunst zu Beitzen, Nebst den Zusätzen des Königs Manfredus aus der Handschrift heraus gegeben. Albertus Magnus von den Falcken und Habichten. Uebersetzt von Johann Erhard Pacius, Diaconus und Rect. zu Gunzenhausen*.

This is a beautifully printed, small octavo volume, dedicated to the Margrave and Prince of Onolzbach (Ansbach), at whose command the translation was undertaken. After a "Foreword to the Reader" (in which he relates the difficulties of the translation and the fact that he is translating from Velser's edition), the Reverend Pacius begins his work with the translation of Velser's "Dedication" to Prince Ferdinand and of his "Remarks to the Reader." The woodcut of Manfred and the two falconers is then reproduced. There follows a translation of the entire Velser text, including the poem on the origin of falconry. The translator supplies also a topical alphabetical index, covering thirteen pages, and, finally, on nine pages, a German glossary of falconer's terms.

15. Johann Gottlieb Schneider, Leipzig, 1788-89. This edition is published in two folio volumes. The work is dedicated to Frederick William II, King of Prussia and Elector

neri ab alio. Alii in struendo manu
 suetudine exire d' manu artificis
 et ad eum manu redire. Alie in doc
 do eis ut sciat exire illas aues qd
 artifex uult & quomodo uult
 exire & p se solam no exirent. A
 ut n' uo in. Alie in struendo ad ue
 nens no utpacti. eis ia arte do
 cio. p' h'is que fut & alie ope
 nes n' modici utiles ad p'p'ri
 s. in oseruado. ues utpactes in
 sanitate qd opus qd ab eis req
 rit h' artifex in p'ficiant & alie
 i curando exotias.

Ordi qui auctores p' d' oebz i. arte
 ipi & scdm h' doctrina uroz teta
 tui h' libri p'ntet p' ordine opo
 quas dymus p' naq; e. acquirere
 re qua aduinitu d'mere & man
 suetudine & sic de certis quod totu
 p'ntetur pluuus in quantu que
 q; tenetur sui locu sortita d'ent
 Instrumta aut p' que artifex iop
 ouib; suis oca hanc. mtem suam
 sui matiam confect h'ac m'nto is
 me. fut d'ua. na. quea. s' ingren
 do. ues utpactes. sic regia. liquet
 et h' ai quib; capiut. cu. nub; &
 m'p'ia. qm. capiut utpactes ubi
 gra. cu. m'p'ia. falcones. qd'ann
 fut id'medo. u. aduinitu. ut ma
 leolu. lacti. & longa. secula. ouem
 outa. & h' queam. s' in manu
 oficiat. uo. detitio. ut id. qd. dr. tra
 toriu. apella. tui. h' uictoria. &
 similia. queam. i. uictu. ipi
 exire d' manu & ad manu redire
 ut id. qd. filer. & s' u. op'ia. dr.
 loyru. cu. d'ub; & s' in. d'ub; & a
 lu. cu. quib; reuocant. ad. h' oem.
 quea. in. docedo. ipi. ut. sciat. cap
 auca. quia. uult. artifex. & quom
 uult. sciat. id. qd. dr. t'ina. siue. fut
 d' grue. sui. de. syrone. sui. de. alia. a
 ue. siue. de. posse. leporina. impleta
 palis. & s' u. m'ia. que. h'ecant.
 ad. t'ina. queam. uult. s' u. i. u. m'

do eis id docens ad capiendu. aues ut n
 p'ntu. p'ntans. a. rotheca. d' u. d' u. a
 & h' queam. i. oseru. do. lam. is. & qn
 mutat. pen. ut. d' u. a. que. dr.
 muta. & pluu. i. ae. et. m'ite. median
 rum. qd'ann. ma. u. do. exotias. ut
 rpe. medicane. & ual. i. necessaria. ad. d'
 eu. ipi. medianas. de. singulis. h'oz
 i. s' t' u. d' i. ubi. ouerent. ;

De diuersitate madorum per quos
 habentur falcones. et quomodo te
 nendi sūt. & nutriendi. ;



Sequitur dicere modos p
 quos h'ntur falcones. mo
 di. aut. s' quos h'nt plures
 sunt. unus. modus. e. qn
 d' u. de. m'go. alius. mod
 est. qn. ia. exierunt. u. d' u. et. capiunt. ai
 certis. instrumtis. ad. huc. n' m'ia. elon
 gati. a. m'go. t'ius. modus. e. qn. capiut
 tur. t'p. aut. p' u. qn. s' fugientes. h' r
 gus. mutat. se. & transeit. d' regioe. u
 na. i. alia. quintus. modus. e. quando
 capiut. t'p. u. u. qn. s' h' o. r. u. d' u. ad
 loca. n. a. u. i. t' u. s' u. s' u. e. u. n. r. e. c. e. s. s. e. n. t. u. r
 ut. d' u. i. e. p' t' u. s' u. s' u. e. qn. a. r. t. u. s' u. s' u. e.
 mod. e. qn. s' t' u. s' u. e. h' e. m. u. s' u. e. capiunt. in
 regioib; i. quib; reuocant. ad. h' yema
 dy. & t' u. m' illo. qui. transeit. qua
 it. illos. qui. reuocant. capiut. s' u. r. i. & a. l. i.
 q. mutat. una. muta. ul' pluri. ;

est qn ia exierunt u. d' u. et capiunt ai
 certis instrumtis. ad huc n' m'ia elon
 gati a m'go. t'ius modus e qn capiut
 tur t'p. aut. p' u. qn. s' fugientes. h' r
 gus. mutat. se. & transeit. d' regioe. u
 na. i. alia. quintus. modus. e. quando
 capiut. t'p. u. u. qn. s' h' o. r. u. d' u. ad
 loca. n. a. u. i. t' u. s' u. s' u. e. u. n. r. e. c. e. s. s. e. n. t. u. r
 ut. d' u. i. e. p' t' u. s' u. s' u. e. qn. a. r. t. u. s' u. s' u. e.
 mod. e. qn. s' t' u. s' u. e. h' e. m. u. s' u. e. capiunt. in
 regioib; i. quib; reuocant. ad. h' yema
 dy. & t' u. m' illo. qui. transeit. qua
 it. illos. qui. reuocant. capiut. s' u. r. i. & a. l. i.
 q. mutat. una. muta. ul' pluri. ;

Alii uo qui h'nt a m'go. h'nt simili plu
 r'ibi. mo. u. i. modus. e. qn. capiut
 t' oua. d' m'go. & sub. m'ntunt. u. u. l. ; do
 methas. ad. eu. i. l. u. d' u. s' u. e. i. s' u. e. m'go.
 qn. a. u. s' u. e. d' u. s' u. e. p' u. a. ul' m' u. l. l. u. a.
 l' o. r. y. s' u. e. m' u. l. l. a. t. e. n. e. e. p' p' o. l. u. d' u. s' u. e.
 Ali. mod. e. qn. ipi. exiut. d' m'go. n' h' u.
 tes. pluu. i. a. s' u. e. p' e. n. a. s' u. e. a. l. i. q. u. i. u. s' u. e. ad
 u. o. l. u. d' u. s' u. e. t. e. n. t. u. m' o. d. u. s' u. e. i. l. l. a. q. a. m' u. t. u.
 l. a. m' u. d' u. s' u. e. i. d' u. s' u. e. m' u. s' u. e. s' u. i. c. o. p. o. r. u. s' u. e. h' r.
 g. y. s' u. e. a. l. i. mod. e. qn. l. a. m' u. d' u. s' u. e. d' e. d' e. r. u. t.
 u. i. q. u. a. n. t. u. s' u. e. n' o. s' u. e. i. n. u. a. t. e. s' u. n. t. p' e. n.
 n' e. & p' l. u. m' e. q. u. a. n. t. u. s' u. e. n' o. s' u. e. a. t. o. s' u. e.
 d' i. u. a. r. u. d' e. l. a. m' u. d' u. s' u. e. & p' l. u. m' u. s' u. e. s' u. i. m' l.
 m' y. r. i. s' u. e. a. l. i. u. s' u. e. modus. est. qn. l. a. m' u. l.

PLATE 20.—Folio 35^r of the Bologna copy of the *De Arte Venandi cum Avibus*, showing the initial of Book II, chapter i. Note how the decorative scroll forms an integral part of the design, and compare with that of fol. 1, Plate 11.



PLATE 21.—Incipit from *Le Livre de la Chasse* of Gaston Phebus, Comte de Foix (Geneva MS. Petau 169).



Dieu nom et en
 l'homme: &
 de dieu ara
 teur et sent.
 & toutes ch
 ses et du benoit son filz ie
 su crist et du saint esprit
 & toute la sainte trinite
 et de la vierge marie et de

tous les sains et saintes
 qui sont en la grace de
 dieu. le gascon qui la grace
 de dieu surnomme sebus
 Conte de forz seigneur de
 bearne qui tout mo' tere
 me sus delite par chaci
 al en trois choses Cest al
 sanow sune si est en armes

PLATE 22.—Incipit from *Le Livre de la Chasse*, bound in with the copy of the *De Arte Venandi* in the Württembergische Landesbibliothek, Stuttgart. (See Plates 16 and 17.)

per nutritionem et humorum copiam. **P**rima capillorum et pilorum quae rumpuntur aut resindunt restaurat quantum fuerit perditum. et amplius cum pronuntiata successione vaporum generatio ipsorum in determinata longitudine suscipiat. plumis uero et penis ideo accidit sic. cum enim determinata habeat quantitatem si cordantur non restaurat et quod deperdit. quare cum contingat cordatioe usque ad radicem processu temporis proterendi. sine substituentur aliter. ceteris quae omnino plumis et penis. quae sunt insufficienti muneri ob imperminitates aere. et praesens inuolubus ad uolandum. & cetera.

Singulis uero annis mutantur plumagium. cum uis sit sufficiens ut annuimodo contingat quod aues non rapaces a naturam suae principio mutantur pueri sunt complecti et perfectae et adsumunt aliud plumagium quod perfectat et complecti proportionaliter et eo termino in quo corpus ipsius a uis complecti et hoc plumagium secundum deponit et mutatur iterum incompleto eiusdem primi anni. sic est uidere in fraganis. pidiabus et cornicibus et plumbicibus. quae primo deponunt plumagium bis. Aues uero rapaces primo anno deponunt et renouant plumagium suum semel. Causa autem pro qua primo anno semel accidat mutatio plumagium rapacibus et non rapacibus bis sumi ex eo quod dictum est in capitulo de plumagio. scilicet quod non rapaces quibus imbecillitas plura nocumta quae rapacibus indigentur plumis et penis. praesens cum quibus et nocumta fugerent et escam sibi acquirerent maxime illis quibus parentes non fecerit escam. et quibus carentibus huiusmodi naturae quae rapaces onerant eis penes aere debiliores in et moliores perfectiores. et a corpore. carente uero aere a corpore in maiore foetore. et pro copia nutritionis. pueri plumae et penes magis insufficientes. et tunc copiam

ut malis tantum dicitur et non substituitur alias firmiores. pro hoc quod huiusmodi in se solidior et uis seade sufficiens et tunc copiam usque; aere a plenitudine anni et tunc pro abundantia huiusmodi deponit huiusmodi plumagium secundum et succedit tunc quod sufficit durare penes. Rapacibus uero quibus; non uiminet cor nocumta; sunt sic aere non quod non uiminet. non onerantur plumis et penes. uelociter in. praesens; penitent. In onerantur firmiores et duriores perfectiores. praesens aere pro quod sufficit durare et tunc copiam usque; aere a plenitudine anni. et ideo sicut solum uis plumagium primo anno. Sigul uero. annis succedentibus; semel mutat plumagium in rapacibus quod non rapaces. praesens praesens. et tunc in quo mutatur caput

Sed aut in quo incipit mutatur plumagium multo pro primo est uer. In uere naque; habundat huiusmodi. huiusmodi; praesens superfluitates de quibus; sic plumagium et conueniens fit multo plumagium in uere; quibus; succedit et tunc in quibus uelociter. et frigore et praesens et tunc crescit et firmat penes. tunc quod sufficit tunc tunc quod facit aues in. in praesens tunc ad loca aere tunc huiusmodi. si in alio tunc quod in uere et tunc ouis; mutatio plumagium quae ad modum dictum est super de partu anni. Quae tunc alia aues quae molitatur mutat in capite et huiusmodi praesens mutationum. Accidit praesens naturam praesens in diuisis praesens. In naque; huiusmodi mutat in capite plumagium suum. anno completo in praesens. sicut praesens naturam suae. sic accidit aere in tunc tunc tunc. et huiusmodi. in huiusmodi; quibus; uis; aere a plenitudine; aere in sui renata incipit praesens; desiccat et hoc tunc opum accidit ex motu superiorum et diuisis praesens huiusmodi in ma. agit. In uero mutatur plumagium. Praesens autem mutatur plumagium duplex est. alii est ordinatus. alii in ordinatus. ordinatus uis est quod non sicut deponit multe penes huiusmodi aere susti

of Brandenburg. The first volume constitutes a second Latin edition of Velser, omitting that editor's "Dedication" and "Foreword to the Reader," as well as the index. After a short "Translator's Dedication," there follows a long Latin introduction by Schneider in which the very learned editor gives an account of the studies made by him in preparation for his task of editing and commenting upon the *De Arte*, which he carried on with considerable skill as a zoölogist. However, as Baron Pichon has pointed out, it seems strange that Schneider should excuse himself for not consulting other possible copies of the *De Arte Venandi cum Avibus* and for not supplying more information about the work and its author because of his residence away from great libraries. Still, Pichon was himself unaware of the existence of the Vatican text (from which the Velser edition was prepared) and was acquainted only with those manuscripts reposing in Paris libraries and his own copy, purchased in Italy. He knew of the existence of Rector Pacius' translation and rightly conjectured that it was taken from Velser.

Volume I of Schneider's work contains the twenty-third book of the Albertus Magnus treatise but omits the poem with which Velser filled the last pages of his publication. There are no illustrations in Volume I.

The second volume (1789) of Schneider's work is entitled: *Ad Reliqua Librorum Frederici II Imperatoris et Alberti Magni Capita Commentarii quibus non solum avium imprimis rapacium, naturalis, set etiam seculi tertii et decimi Litteraria Historia illustratur. Cum auctario Emendationum atque annotationum ad Aeliani de Natura Animalium Libros, Auctor Jo. Gottl. Schneider, Saxo. Lipsiae.* It contains a "Foreword to the Reader," followed by careful notes on the *De Arte Venandi cum Avibus*. These latter annotations are concerned chiefly with the identification of the birds and other animals of the first book and with their structure.

Then come notes on Albertus Magnus, followed by a catalogue of "Authors on Falconry," as well as a Latin-German vocabulary of falconry, remarks on the flight of raptorial birds, on variations in avian structure, and on the moulting of land and water birds, and by emendations to the text. A section is given, also, to corrections of and to other remarks on Aelian. Schneider supplies six copper-plate engravings of bird structure, with an explanation thereof, and an account of various species of birds of prey. The second volume closes with an index.

16. The last printed version of the *De Arte Venandi* known to us appeared under the title, *Des Hohenstaufen Kaisers Friedrich II, Bücher von der Natur der Vogel und der Falkneri*, etc., folio, Berlin, 1896. This translation is the work of the two Schöpfers, father and son, and contains many valuable and helpful notes.

The Bologna and Vatican manuscripts were used as the chief sources of this present English translation. All important differences as to the material contained in them have been noted in the course of the work; they may be summarized as follows:

The Vatican text contains the first two books only, but with additions by Manfred that, in the original text, are marked by the words: *Rex*,¹³ *Sunt et alias rationes quas Manfredus Rex Siciliae*,¹⁴ and *Addidit Rex*,¹⁵ as well as the first thirty chapters of Book II, the addition of which is explained in chapter xviii of that book. There are other, shorter, unmarked passages that were added to Frederick's work by Manfred, or by his scribe; these, also, we have indicated in the course of our translation. There are, it must be remembered, passages in the Bologna text that

¹³ Vatican MS., fol. 5^v (Book I, chap. iv); fol. 38 (chap. liv); fol. 80 (Book II, chap. liii); fol. 89 (chap. lix); fol. 90^v (chap. lx); fol. 96^v (chap. lxix).

¹⁴ *Ibid.*, fol. 36^v (Book I, chap. liii).

¹⁵ *Ibid.*, fol. 38 (Book I, chap. liv).

are entirely lacking in the Vatican Codex; and these, too, we have noted. Among them we find the passage on birds of prey in Book I, chapter iii, the end of chapter vii, and a portion of chapter viii. In chapter ix of the Bologna manuscript, as well as the Vatican manuscript, there is a passage that is repeated later in chapter xv-A of the former codex. This repetition is fully noted in footnotes to those chapters. Shortly after the beginning of chapter xxiii of the Vatican text some folios are lost from that manuscript (after fol. 16), the subject matter of which is contained in about six folios of the Bologna text and forms the greater part of chapter xxiii, the whole of chapters xxiii-A, xxiii-B, xxiii-C, xxiii-D, xxiii-E, xxiii-F, xxiii-G, and xxiii-H, and the beginning of chapter xxiii-I, in this translation. In chapters xxiv and I, of Book I, there are two short passages that do not occur in the Vatican Codex; and at the end of the first book of the Bologna MS. there is a repetition of the beginning of chapter liv of that book. In Book II, chapter xxxiii, of the Vatican MS., a passage is missing. This defect is occasioned by the loss of a folio after folio 58. The text of that codex breaks off abruptly and shortly before the end of Book II. There are other minor differences, which are pointed out in the footnotes to this translation.

The Bologna Codex is the oldest of existing six-book manuscripts and may, in part, be one of a number of copies of the *De Arte* prepared during Frederick's lifetime. We know that a copy was lost during the siege of Parma in February 1248, also that Frederick sent a copy of his work to Manfred (from which the Vatican Codex was prepared); and it is quite possible that there were other losses.

Professor S. A. Luciani,¹⁶ who has given us an excellent account of this manuscript, says that the Bologna Codex has heretofore been ascribed to the fourteenth century be-

¹⁶ *Archivio Storico per La Calabria e La Lucania*, Anno III, Fasc. II (Rome, 1933).

cause of the promiscuous use of the two forms of the letter *d*, a characteristic of the Humanistic handwriting of that period. But, as Luciani points out, this is a peculiarity also of the script of the thirteenth century called by Piscicelli¹⁷ Latin-Gothic, and which the Rev. Philip Moore (whom we have consulted and who has given us valuable advice concerning the chirographies of this manuscript) prefers to call "perduring caroline minuscule." Moreover, on folio 34^v, column 1, at line 45 (i.e., near the end of Book I) the handwriting changes. Here the first script is succeeded by a second that, because of both its form and the type of its abbreviations, must (according to Professor Luciani) be called Lombard-Cassinese. He also believes that the chirography corresponds with the decorative detail of the manuscript, and that it follows the characteristics of the work executed at Monte Cassino and other monasteries connected with it, especially that of Santa Sofia of Benevento, where the style prevailed for about four hundred years. With this opinion, however, other authorities disagree, and, in our judgment, with good reason. Dr. Ullman¹⁸ has pointed out that "the most characteristic letter of Beneventan is *a*, shaped at first like *cc*, later like *oc* joined together." He also says that "the *r* is highly individual. It consists of a straight line extending slightly above and below the line, with a knobbed shoulder and a horizontal connecting stroke." None of these traits is found in the Bologna text. With regard to the scrolls of the illumination, their style would indicate a date not earlier than the second half of the thirteenth century. Upon close examination, however, it seems likely that in the first part of the manuscript, i.e., Book I, they form a subsequent addition to the original miniatures.

¹⁷ Piscicelli-Taeggi, *Paleografia artistica de Monte Cassino*, Latin (Montecassino, 1882).

¹⁸ B. L. Ullman, *Ancient Writing and Its Influence* (New York, 1932), p. 98.

Of the first script in the Bologna Codex, the Rev. Father Moore says: "The first script immediately struck me as caroline minuscule with certain modifications . . . the rounded 'd' and the joined letters, the 'g's and the final long 's' though the latter is found also in eleventh-century caroline minuscule." This authority feels sure that the script is not Humanistic (a hand based on the caroline minuscule of the tenth and eleventh centuries) because of these same modifications, which are never found in that script (especially the fused letters and the g's) Moreover, the latter script came to Italy only in the early fifteenth century. As we have said, Father Moore suggests that we call the script a "perduring caroline minuscule," and thinks it is probably not earlier than the second quarter of the thirteenth century (because of the fusing of the letters) but may be found as late as the middle of the fourteenth century. It is our belief that the loose form of the round s indicates an early date for this portion of the manuscript.

Concerning the second handwriting Father Moore says: "Of the two scripts the second can be more certainly dated. The final 's' of this script, the closed 'g's, the frequent use of the round 'r' all seem to indicate the second half of the thirteenth century. The other characteristics, though not conclusive in themselves are, nevertheless, found in writing of this period. In my opinion, therefore, it is most probable that this script dates from the second half of the thirteenth century; but I can't say positively that it does not date from shortly before 1250, or from shortly after 1300." He asks the following question: "Was the manuscript written consecutively from beginning to end, and the change of script made near the end of the first book, or was the manuscript originally written in the second script and then the first folios destroyed and later recopied in the first script?" We feel that the first hypothesis must stand, because

the change of hand occurs near the bottom of the first column of a page¹⁹ and it does not seem possible that the first script was written in after the second. Furthermore, the chapter and paragraph headings above the first script are written in the same hand as the second part of the manuscript; and, as we have already remarked, the scrolls at the beginning of Book I have the appearance of being added to the miniatures, whereas in all the subsequent books they form an integral part of the original design.

At this point it is well to discuss another question, one raised by Professor Luciani, and that is the dedication of the various manuscripts. The Bologna Codex opens with the words: *Presens opus agendi nos induxit instans tua petitio, Vir clarissime M. E.* In the Mazarine and Dobrée texts the opening words are the same, but the initials are *M. S.*; and in the Valencia manuscript the second initial is effaced by a blot on the parchment. Luciani suggests that the initials *M. E.* refer to Malik El-Kamil (or, as it may sometimes have been written, Elkamil), the Sultan of Egypt with whom Frederick had such friendly relations at the time of his Crusade in 1228 and later by correspondence after his return to Italy; and that it is quite possible the Sultan encouraged him in his proposed plan to prepare a work on falconry for the use of the Western world. We approve this suggestion. Malik El-Kamil died in 1238, and it may be that the present manuscript represents a start made before that date, carried to the point where the handwriting changes, and then for a time set aside.²⁰ It is also possible that a second copy of the still incomplete work was then dedicated to Malik-es-Salih, the son of El-Kamil,

¹⁹ See Plate 23.

²⁰ In the year 1240 a Latin translation of the Arabian Moamyn's work on falconry was being prepared by the learned Theodore for Frederick, who himself corrected it during the siege of Faenza in 1241, a circumstance that indicates the Emperor was still gathering material for his work.

with whom also the Emperor was on friendly terms.²¹ This would explain the *M. S.* of the Mazarine and Dobrée manuscripts, assuming these codices to be copies from a (now lost) codex made during Frederick's lifetime.

It is the opinion of the late Charles H. Haskins that the *De Arte Venandi* assumed its final form in the years 1248-50, "when Manfred was fully grown and the emperor sojourned in the neighbourhood of Apulia, to which the treatise especially relates." This would account for the decision to dedicate his treatise on falconry in its final form to Manfred. This young (illegitimate) son of Frederick II had for a long time been his father's favorite companion and shared his love of falconry. It would not be strange if his father gave him a copy of the *De Arte* inscribed to *Fili carissime Manfredi* and left to him all the notes he had made for the completion of his treatise.

If the foregoing suppositions are correct, then Frederick began his work sometime after his return from the East and had almost completed the first book before 1238, probably during the peaceful years 1230-35 spent in southern Italy, when Frederick was working on the Constitutions of Melfi (the *Liber Augustalis*) and building towns and castles. The following years were spent in affairs of state that included a long sojourn in Germany and northern Italy (1235-40), necessitated by the rebellious behavior of his son Henry, the Regent of Germany, and by trouble with the Lombard League and the Holy See. It is doubtful whether much actual work on the manuscript was accomplished during that period, but the spring of 1240 saw the Emperor again in southern Italy and especially at Foggia and Capua. Between that date and the attack on Faenza, Frederick probably took up his work once more, and it is possible that a

second manuscript (that dedicated to *M. S.*) was begun and the work carried to completion in its present form between that year and his death in 1250.

Just when the Bologna manuscript was completed it is difficult to say. It may have been before Frederick's death; but it seems to us more probable that it falls into a later period. As we have shown, it is very closely related to the Mazarine text (which bears the dedication to *M. S.*). It is possible that two or more early manuscripts were completed at about the same time.

Manfred undoubtedly undertook to prepare for himself a special, revised edition of his father's great work; but he, also, died before his task was completed, although his efforts resulted in the wonderful Vatican MS., Pal. Lat. 1071. The date of this last manuscript has been fixed for us by the fact that the notes added by Manfred are indicated by the notations *Rex, Rex Manfredus,* and *Addidit Rex.* Manfred was crowned in Palermo in 1258, and died in 1266. We must therefore ascribe the Vatican Codex to that period, when the court was in residence, chiefly, at Barletta. The chirography of the manuscript would corroborate this supposition, for the codex is written in a hand which Dr. Ullman refers to as "Rotunda," i.e., an Italian-Gothic hand of the thirteenth century. This chirography preserves many of the forms of the caroline minuscule.

As we have already remarked, the translators have compared the first two books of the Bologna text with the Vatican (or Manfred) manuscript; and, although it is possible (even probable) that the manuscripts known to us offer a complete review of the imperial author's work (as it remained at his death), yet we are quite sure that they do not present that great treatise in the form originally designed for it by Frederick. There are throughout the *De Arte* cross references to matter contained either in the book in which they oc-

²¹ Early in 1241 Frederick concluded a treaty with Malik-es-Salih through his envoys Richard, Duke of Cornwall, his brother-in-law, and Roger de Amicis.

cur or to material in another of the six books as we now have them. In addition to these, a third set of allusions refer to topics not fully, or even partially, treated in the present work and which Frederick evidently intended to include in his completed opus.

References of the first class are comparatively numerous; here are some of them: First, in Book I, when referring to the food and feeding of falcons, Frederick says, *Quorum ciborum maneries diximus in capitulo de diversitate ciborum avium*;²² and, of moulting, *Causa autem propter quam in primo anno semel accidat mutatio . . . sumitur ex eo quod dictum est in capitulo de plumagio*.²³ In Book II, when speaking of the manner of placing a falcon on the perch, he writes, *ponita longa per ambas anulos jactorum et notata circa ipsos eo modo qui dictus est in capitulo de longa*;²⁴ and, when discussing bathing, *et quo modo succuriri debeat diverberationibus quas fecerit dicitur in capitulo de mansuefactione falconi totaliter deciliatis et quo modo levandus est de sedilibus hujus falco semideciliatus haberi potest eisdem capitulis*.²⁵ In the same book, in the last chapter, concerning the hood, he writes, *et etiam contra frigus faciant cetera quam diximus fieri aliis portandis sine capello*.²⁶ In Book IV, on flying saker falcons with the wind, occurs the statement, *Quem ad modum jactandi non approbamus propter causas dictas in capitulo de modo jactus*.²⁷ In Book V there is a similar reference: *Unusquisque falco secundum manierem suam in loco et in tempore sibi con-*

venienti jactetur, ponatur hoc capitulum de modis volatum sacrorum ad ayrones.²⁸ And, finally, in Book VI we have the following reference: *Alias etiam occasiones propter quas minus libenter ad loyrum veniunt dicemus infra tractabitur de peregrinis falconibus quomodo venantur*.²⁹

Of the second class of cross references, there are numerous examples. In Book I are the following references to Book II: *De generibus autem dicitur in tractatu secundo et in ceteris hujus libri*;³⁰ and *de horum autem falconum et accipitrum modis plenius et evidentius manifestatur in secundo tractatu et in aliis in quibus nostra intentio per se super eos descendit*;³¹ again, referring to the nesting habits of birds of prey, *ut in tractatu de rapacibus dicitur plenius*.³² Also in Book I there is this reference to Book IV: *Grues habent tres deffensiones cum pedibus ut dicitur in tractatu de venatione*.³³

In the Preface to Book II we come upon the general remark, *In hoc tractatu secundo et in ceteris accedemus magis ad nostrum propositum*.³⁴ And in Book II, chapter xvi (found only in the Vatican Codex), there is a reference to Book I (chapter xxiii-A) when speaking of the return (migration) of birds, *secundum quod dictum est in generali capitulo de reditu*;³⁵ and one to Book IV, *Equus et qualis debet esse et quorum morum dicitur plenarie in tractatu de venatione girofalcis ad grues*.³⁶ This last reference is also found in the Vatican version,³⁷ although that manuscript does not contain a Book IV.

²² Book I, chapter xxiii-H (fol. 16^v), a reference to chapters ix, xii, and xv-A.

²³ Book I, chapter lvii (fol. 34), a reference to chapter xv.

²⁴ Book II, chapter li (fol. 47^v), a reference to chapter xxxix.

²⁵ Book II, chapter liv (fol. 51), a reference to chapters lvi-lix.

²⁶ Book II, chapter lxxx (fol. 68), a reference to chapter lxxii.

²⁷ Book IV, chapter xxix (fol. 105^v), a reference to chapter xiii.

²⁸ Book V, chapter vii (fol. 111), referring to chapter xx.

²⁹ Book VI, chapter v (fol. 128), referring to chapter xx.

³⁰ Book I, chapter iii (fol. 3^v).

³¹ Book I, chapter xv-A (fol. 8^v).

³² Book I, chapter xxiii-F (fol. 15).

³³ Book I, chapter lv (fol. 32).

³⁴ Bologna MS., fol. 35.

³⁵ Vatican MS., fol. 52^v.

³⁶ Book II, chapter lxxi (fol. 60, Bologna MS.).

³⁷ Vatican MS., fol. 98.

In Book IV there is a reference to Book I—*Quae segregate erant in ipsis regionibus congregantur in turmas ad redeundum ut dictum est in capitulo de reditu avium.*³⁸

In Book V there is an allusion to Book III—*ambo isti canes debent esse docti succurrere ut supra docuimus,*³⁹ and another to Book IV, *quando vero propter crassitiam distringi debet fame ut docetur in capitulo de macrifactione et pasci debet carnibus madefactis in aqua.*⁴⁰

In Book VI there are two references to Book II: *quod si faciat quia male tractus est per signa quae supra dicta sunt de falconibus male tractatis, odium quem habet in homine cognoscetur per signa que supra dicta sunt de falcone timente de homine;*⁴¹ and, in the same chapter, *doceatur ad impositionem capelli ut docuimus in tractatu de capello.*⁴² In this last book there is also one reference to Book III—*equitet circumeundo et faciat reliqua omnia que dicta fuerit in capitulo de loyratione falconum et pascat ipsum sicut dictum est in capitulo eodem.*⁴³

Of the references to subjects not in the *De Arte Venandi* as it has come down to us, five are to the book on *Falcons, Their Diseases and Injuries*, i.e.: in Book I, *ponamus . . . illa que necessarium est scire in tractatu nostro de egritudinibus;*⁴⁴ in Book II, *ad purgandum caput de malis humoribus ut patebit in tractu morborum,*⁴⁵ and *si non balnearent se acciderent plures morbi de nimis siccitate ut dicemus in tractu de morbis;*⁴⁶ in Book V, *si vero propter rupturam et malem mutationem pennarum quarundam accidet, corri-*

*gende erunt propter [per?] incisionem aliarum penarum in eis ut docetur infra;*⁴⁷ and in Book VI, *si vero propter infirmitatem hoc faciat quod cognoscetur per signa que dicentur in capitulo infirmitatis.*⁴⁸

In the category of cross references there are also those that speak of a "Book on Hawks": In Book II, chapter ii, there are the following words: *super hoc loquimur latius in libro de austure ubi loquimur specialius et diffusius dicentes de convenientiis et differentiis.*⁴⁹ And at the end of chapter xxviii, "On the Lanner Falcon," Frederick says: *Dictum de Falconibus secundum genus et de omnibus specibus ipsorum quibus homines usi sunt dicendum est de specibus accipitrum quibus utimur, videndum de austure et niso, sed quia intendimus specialem tractatu de eis facere exinde tacimus ad praesens.* This is followed by the heading to chapter xxix: *Dicto de forma et plumagio convenienti austorum saurorum et eorum qui mutati sunt dicendum est de sperverii.*⁵⁰ In chapter xxxiii the imperial author says: *de loco vero in quo nutriri debent pulli accipitrum secus est, ut dicitur in tractatu de accipitribus.*⁵¹ In Book III there is the following reference to the subject of moulting and the care of falcons while in the mews: *Et fiet eis omne id quod fieri existentibus in muta quod ad presens non dicemus, quoniam materiam nostram non dat modo nobis loqui de muta, sed dicemus infra quando dicemus de muta et de omni eo quod convenit mutationem.*⁵²

These quotations are ample evidence, not only that the *De Arte Venandi cum Avibus* in its six-book form is a single, separate treatise, but also that the Emperor had in mind an even more comprehensive monograph. For

³⁸ Book IV, chapter ii (fol. 89^v).

³⁹ Book V, chapter ix (fol. 111^v).

⁴⁰ Book V, chapter xvii (fol. 115^v).

⁴¹ Book VI, chapter xiii (fol. 131^v).

⁴² Book VI, chapter xiii (fol. 131^v).

⁴³ Book VI, chapter ix (fol. 130^v).

⁴⁴ Book I, chapter xxiii-1 (fol. 18^v).

⁴⁵ Book II, chapter lv (fol. 52).

⁴⁶ Book II, chapter lxix (fol. 58).

⁴⁷ Book V, chapter xvii (fol. 115^v).

⁴⁸ Book VI, chapter xi (fol. 131).

⁴⁹ Book II, chapter ii (Vatican MS., fol. 49).

⁵⁰ Vatican MS., fol. 57.

⁵¹ Bologna MS., fol. 36.

⁵² Bologna MS., fol. 81 (Book III, chapter xix).

instance, there can be no doubt that Frederick intended to include in his book a section on the diseases of falcons and hawks, which would doubtless have contained an account of common injuries to birds used in sport and a discussion of the important topic of moulting and its normal and abnormal manifestations.

The promises in Book I (made in both the Vatican and the Bologna texts) to discuss more fully in Book II the various species of falcons and hawks would seem to have gone unfulfilled if we accept Book II of the Bologna manuscript as Frederick's final edition of that portion of the work. It is here that Manfred's explanation of the insertion of the first thirty chapters of the second book comes to our assistance. In chapter xviii, Book II (*q.v.*), Manfred explains the finding of all the material contained in chapters xix to xxx, the greater part of which certainly belongs to Book II, as evidenced by the references to it in Book I. The royal editor, however, does not say whence he took the material in chap-

ters i to xvii; but it may safely be assumed that it was discovered *in quaternus et notulas libri istius*. As we have remarked in the footnotes to this translation, certain portions of these first chapters of Book II are mere repetitions of material dealt with in Book I, notably chapters iii, ix, x, and xi, which were included (in error) when Manfred's edition was prepared. Nor does chapter v, on "Hawks," belong in this part of the *De Arte*, to which we must add chapter xxix on "Sparrow Hawks." When these last two chapters are considered in connection with references to "a special treatise" on the subject, and especially with that at the end of chapter xxviii, there can be little doubt that it was Frederick's intention, when he had completed the portions of his work dealing with the description of long-winged falcons and their use in hunting, to add a parallel series of books covering the short-winged hawks, and to complete the work with a discussion of the diseases and injuries to which all hunting birds are subject.



The Castles and Hunting Lodges of
Emperor Frederick II

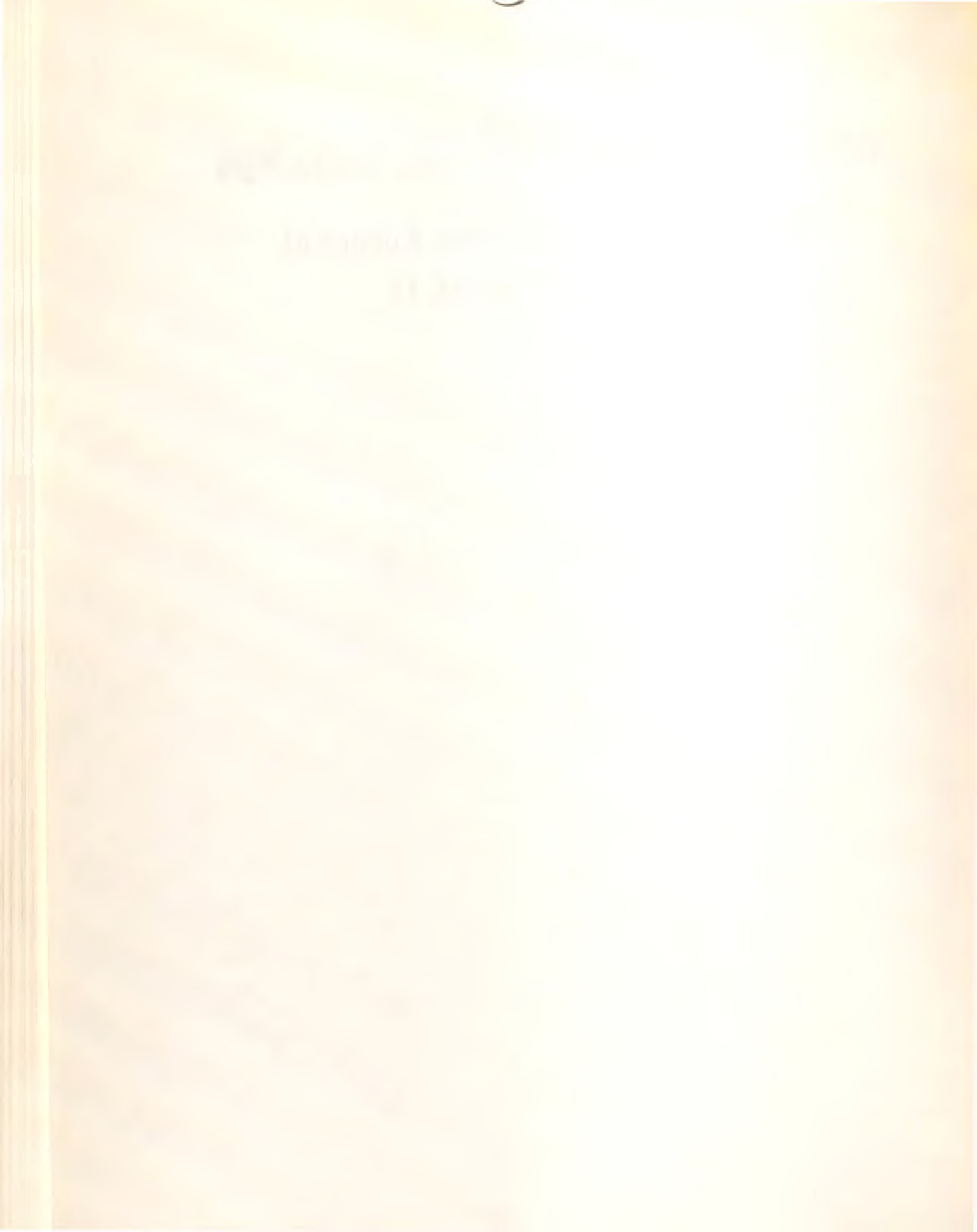



PLATE 24.—Map of southern Italy and Sicily, showing the location of the Emperor's castles and hunting lodges.



PLATE 25.—Fortress of Lucera (1233). It was capable of holding 10,000 troops.

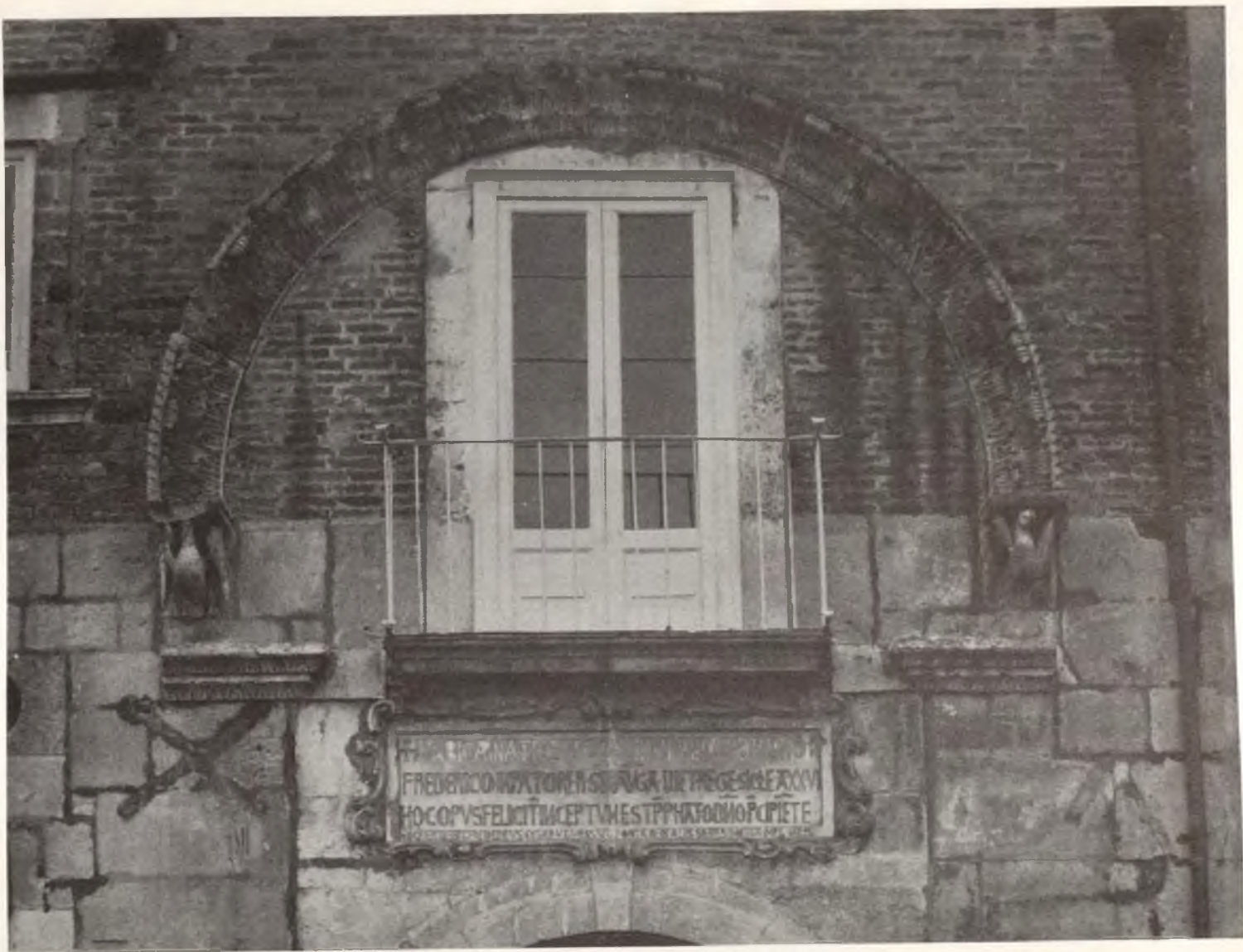

PLATE 27.—Remains of the entrance portal of Frederick's palace at Foggia, with a tablet giving the name of the architect, Bartholomeus, and the date, June 11, 1223.

THE CASTLES AND HUNTING LODGES OF THE EMPEROR FREDERICK II

By CRESSWELL SHEARER, M.A., F.R.S.

THERE is little doubt that next to falconry the principal interest of the Emperor Frederick II was architecture: like his grandfather, King Roger II of Sicily, he was an energetic builder. In his favorite province of Apulia he erected more than twenty big castles of which we have documentary record. Among these were Lucera, Barletta, Trani, Bari, Brindisi, Foggia, besides Castel del Monte, while it is said that during his lifetime he erected more than sixty fortresses in his widespread Empire. In connection with his larger castles it was his custom to build a number of minor dwellings, the *loca solationum* of his correspondence, the pleasure retreats to which he could retire at frequent intervals and forget the affairs of state in the pursuit of falconry, his lifelong absorbing passion.

In the vicinity of his palace of Foggia, where he spent so many of the later years of his life, we know the names of six of these hunting lodges. In its immediate neighborhood was his animal park of San Lorenzo, where he kept his menagerie—that menagerie which so impressed his German subjects when he visited their country, with its elephant, lions, camels, dromedaries, and hunting cheetahs trained to ride on horseback behind their keepers. According to the Florentine chronicler Villani it possessed a bird park for the training of his falcons.¹ Then there was Orta,

¹ This is probably the *parco delle uccellagioni al Pantano di Foggia in Puglia*, referred to by Villani in his chronicle. Villani, *Storia* (Florence, 1587), Vol. I, Lib. 6, p. 125.

Guardiola; while farther afield were Serracapriola, Apricena, and Belvedere (Gargano). In connection with his large castles at Syracuse, Augusta, and Catania in Sicily, we find a similar group of pleasure resorts, such as the *vivaio* of San Cusmano (where he had extensive fishponds), Cantaria, and Chindia (Targia). No doubt many of these were not only hunting boxes where he housed his falcons but extensive properties, the *aratiarum Curiae* of his letters, devoted to general farming and stock breeding, as well as corn culture. The second of these groups was connected with his introduction of the sugar cane into the island, the *Cannae mellite*; for the district inland between Augusta and Syracuse was found particularly favorable for its cultivation.² Archaeological research of the last forty years has been successful in locating many of these pleasure resorts, although in most cases only a few crumbling foundations now mark their former sites.

The Emperor seems to have been interested in all kinds of farming; we read of his vast herds of buffalo, of his 6,000 sheep in Calabria and his 500 cows in Sicily, of bees, pigs, goats, geese, pigeons, peacocks, and other livestock, that he sold in the markets; while we are told that his lands were planted with oats, millet, hemp, cotton, corn, vines, and olives, grown in suitable localities.

In the administration and the management of these country estates the Emperor seems to

² The principal town of this region today bears the name of Militello in memory of the Emperor's industry.

have often employed Cistercian monks,³ probably on account of their renown as the foremost agriculturalists of the time and their ability to read and write and so to keep properly written accounts, about which he was always very particular, frequently giving orders that these should be sent him. These clerics, however, never appear to have been entrusted with the care of his falcons.

One of the Emperor's constructions, his "Parco per Uccellagione" at Gravina, seems, by its name, to have been devoted alone to the care and the housing of his falcons. According to the Renaissance painter, Vasari, it was constructed in the year 1231. Some considerable ruins of this building remain and show that it was of modest proportions, measuring some 192 feet in length by 95 in width. It was formerly a two-story structure enclosing a small rectangular courtyard entered at one end by steps and a gateway surmounted by a tower. Today only the outer wall of the far end of the building still stands; but this clearly demonstrates, with its finely cut stonework and plan of construction, the craftsmanship typical of all the Emperor's buildings.

While Frederick's southern kingdom had a mixed population, in which Arab, Byzantine, and Latin elements predominated, thanks to the Crusades it was the general meeting place of all the Christian peoples of Europe. The Emperor worked hard to introduce some semblance of unity among these heterogeneous elements. In his celebrated Constitutions issued from Melfi in 1231, he was the first monarch in modern times to set up a uniform legal, financial, and administrative order in his kingdom. In medieval times every little community claimed the privilege of making and using its own laws. It is said that in

³ The Cistercians were the great farmers of the Middle Ages, being justly celebrated for their many innovations in agriculture and their success in the breeding of cattle, horses, and other livestock of the farm.

France at this date some sixty different legal codes were actually in use at one and the same time in different parts of the country.

Under Frederick's new unified administration, lay culture first made its appearance and obtained recognition, and practically all the high crown offices were taken from the hands of clerics and given to laymen—a most striking innovation—and, moreover, most of these were Italians and not foreigners. He immediately encountered the difficulty of finding a sufficient number of properly qualified laics to carry out his ideas; for in the thirteenth century the Church was the home of all trained intellect. It was to remedy this defect that the Emperor founded the University of Naples. In the preamble of the charter of this institution he states: "We propose to rear many clever and clear-sighted men, by the draught of knowledge and the seed of learning; men made eloquent by study and by the study of just law. We invite learned men to our service, men full of zeal for the study of *Jus* and *Justitia*, to whom we can entrust our administration without fear." It was the legal spirit that was to control the state, and its officials were to be lawyers.

Along with this reorganization of the commonwealth there went a complete overhaul of its economic foundations. By a series of monopolies of such commodities as salt, iron, steel, silk, and cereals, and by the imposition of custom duties on all commercial imports and the regulation of weights and measures, everything was brought under direct state control and taxation. In this regard Frederick's models were probably some of the Islamic caliphates; for he was in close touch with some of these, for whom he had great admiration, since they were far in advance of anything Occidental in matters of assessment and taxation. The person of the Emperor, however, was entirely outside this elaborate system of taxation and custom dues; and as he was the largest landowner and tradesman in

the kingdom, his profits under these preferential conditions were necessarily large. In part this monopolistic system had been developed by his Norman ancestors; but it underwent at Frederick's hand such elaboration and rigorous application that he was able to dispose of very ample revenues—revenues that greatly impressed his contemporaries and were the vain envy of his successors. It was the large profits of this system that furnished him with the means of undertaking such extensive building operations. There was something of the totalitarian ideal in the state he attempted to found, and much of his legislation seems to breathe a modernity that has not failed to intrigue historians for many generations.

Unfortunately for the Emperor, his southern kingdom was a fief of the Church; for his ancestors had conquered the land at the instigation of the Pope, and recognized him as their overlord. Even Frederick himself had admitted this claim when crowned King of Sicily at the early age of four years, and in attempting these reforms he was brought face to face with the interests of the Church.

The Pope had no desire to see a lay state made of his "Patrimony of St. Peter beyond the Tiber." The Emperor, as a consequence, spent the greater part of his life in conflict with one Pope after another, in an attempt to establish his independence of ecclesiastical authority, being also handicapped by the fact that his position as Holy Roman Emperor rested largely on Papal recognition and support.

In this struggle the strategic and political center of his kingdom rested no longer in Sicily but on the mainland of Apulia, and thither he early transferred his administration. This province is divided into three subdivisions—Terra di Otranto, Bari, and the Capitanata—only the last having any variety of scenery, with fine views of the mass of the

Apennines in the distance, and the high rocky promontory of Monte Gargano.

In the Capitanata the Emperor was in close touch with Rome and could also retain contact with the cities of middle and northern Italy, the chief scenes of his campaigns. Moreover, from the Capitanata he could easily command all the main roads to the south. But there seems to be something else that made him return winter after winter to this region; this was undoubtedly the facilities it offered him for his favorite sport of falconry, for he always kept his best falcons in the castles of this district. The open character of the countryside afforded him advantages not easily found in other localities.

To Lucera, in the center of the Capitanata, in 1224, he commenced transferring large numbers of his Sicilian Saracens, establishing them in a big camp, where they formed an ever ready army against whom all Papal anathemas were wasted—"a veritable thorn in the eye of the Pope," as the historian Matthieu Paris remarks. It was, however, at Foggia, some twelve miles south of Lucera, that he set up his headquarters; and there he seems to have spent much of his time and to have built a modest palace.⁴ This has disappeared, probably destroyed by the violent earthquakes that repeatedly leveled the town to the ground. A few fragments built into the wall of a house are all that mark the former site of the building.

It is certainly difficult to understand the Emperor's liking for the vicinity of Foggia. The town is noted for its almost African summer heat and its lack of rain; during some years rain falls only once in eight months; and its cold winters are proverbial. Moreover, the

⁴ That the palace cannot have been of any great size seems to be borne out by the fact that in the subsequent reign of Charles of Anjou, on the occasion of any state ceremonies taking place at the palace, orders had to be given to erect temporary quarters for the guests. Frederick seems to have been a firm believer in a small but efficient staff of servants.

country surrounding the city is fever-stricken, and until a few years ago all drinking water had to be brought from Naples.

To the resident of the fertile Neapolitan campagna, it is a strange sensation to cross the mountains and look down for the first time on the unending, flat plain (Tavoliere) of Apulia; its drab desolation takes one's breath away. Foggia is set down in the middle of a flat desert with dark, bare earth stretching in every direction as far as the eye can see. Only in the short winter season is the countryside green with grass. From the end of May till the beginning of November not a blade is to be seen; all is withered and burnt with the sun. In former years, during the winter months, vast flocks of sheep and cattle annually descended for grazing purposes from the mountains of the Abruzzi and northern Italy. The country is treeless, except for a few eucalypti planted at intervals along the banks of the small rivers. The tortuous courses of these streams are marked out for seven months of the year by dry gravel beds, with only here and there a muddy pool, fit breeding places of the malarial mosquito. The air of loneliness and desolation of the Tavoliere is equaled only by the great prairies of America.

In the twelfth and thirteenth centuries this southeastern part of Italy enjoyed unusual prosperity as the result of the Crusades, when a continuous stream of trade and commerce passed through all the coast towns of the district.

Frederick, during his residence in Apulia, seems to have rebuilt most of the towns, and many of the castles and cathedrals date from his time. This was the Golden Age of the province, when it enjoyed an importance and prosperity that it has never since attained. The Emperor's constructions in most cases still remain the centers of existing fortifications. At Barletta, Trani, Bari, Brindisi, and other ports, the walls of the great red towers

of the old Hohenstaufen buildings continue to defy the assaults of time, surrounded by the debris of later additions.

It was the Emperor's habit to retire during the hot months of July and August to the high mountains of the Basilicata where at Melfi, Palazzo San Gervasio, and particularly Lagopesole (at an elevation of over 2,070 feet) he could enjoy cool Apennine breezes during the evenings. At Lagopesole he commenced in the last years of his life to erect one of the largest of his castles, which today, after Castel del Monte, is the best-preserved of his buildings. It is, like most of the Hohenstaufen structures, a rectangular, oblong work enclosing two courtyards, measuring 307 feet in length by 193 feet in width. It is said to have been incomplete at the Emperor's death, and has undergone much alteration since then, one end being now a complete ruin. Its majestic, square keep has a certain Teutonic air about it in its square massiveness, that seems to fit in with the somewhat irregular plan of the fortress as a whole, suggestive of the German castle. It was the invariable summer residence of the Emperor's son, King Manfred, during his short reign and, after his death, of his successor Charles of Anjou. It has been the property of the Doria family for the last four hundred years.

In the Terra di Bari the land rises gradually as one leaves the coast, in a series of rolling downs—the Murgie hills—forming an advance guard to the Apennines proper. In places they attain an elevation of almost two thousand feet. Here, at one of the highest points, 1,770 feet above sea level, the Emperor started in 1240 to erect the most famous of all his buildings, Castel del Monte. At this period his finances were in a particularly depleted condition; yet this did not deter him from undertaking one of the most remarkable and for its size one of the most expensive buildings ever erected. It crowns a small, conical hill commanding magnificent



PLATE 28.—Main portal of Castel del Monte. It is all of highly polished breccia marble of a rich red. This portal is worthy of the best period of the Italian Renaissance, although antedating it by two hundred years.



PLATE 29.—An upper-floor room at Castel del Monte, the "Throne Room," or audience chamber (see Plan, Room 3, 2d floor). It shows the sets of triple columns supporting the Gothic vaulting. The walls of the rooms of the castle, up to the level of the horizontal molding, were formerly covered with thin sheets of highly colored marbles, while the floors were decorated with brilliant mosaics in which red, white, blue, and gold were the predominant shades. The door and window frames are of a light orange-colored breccia marble.

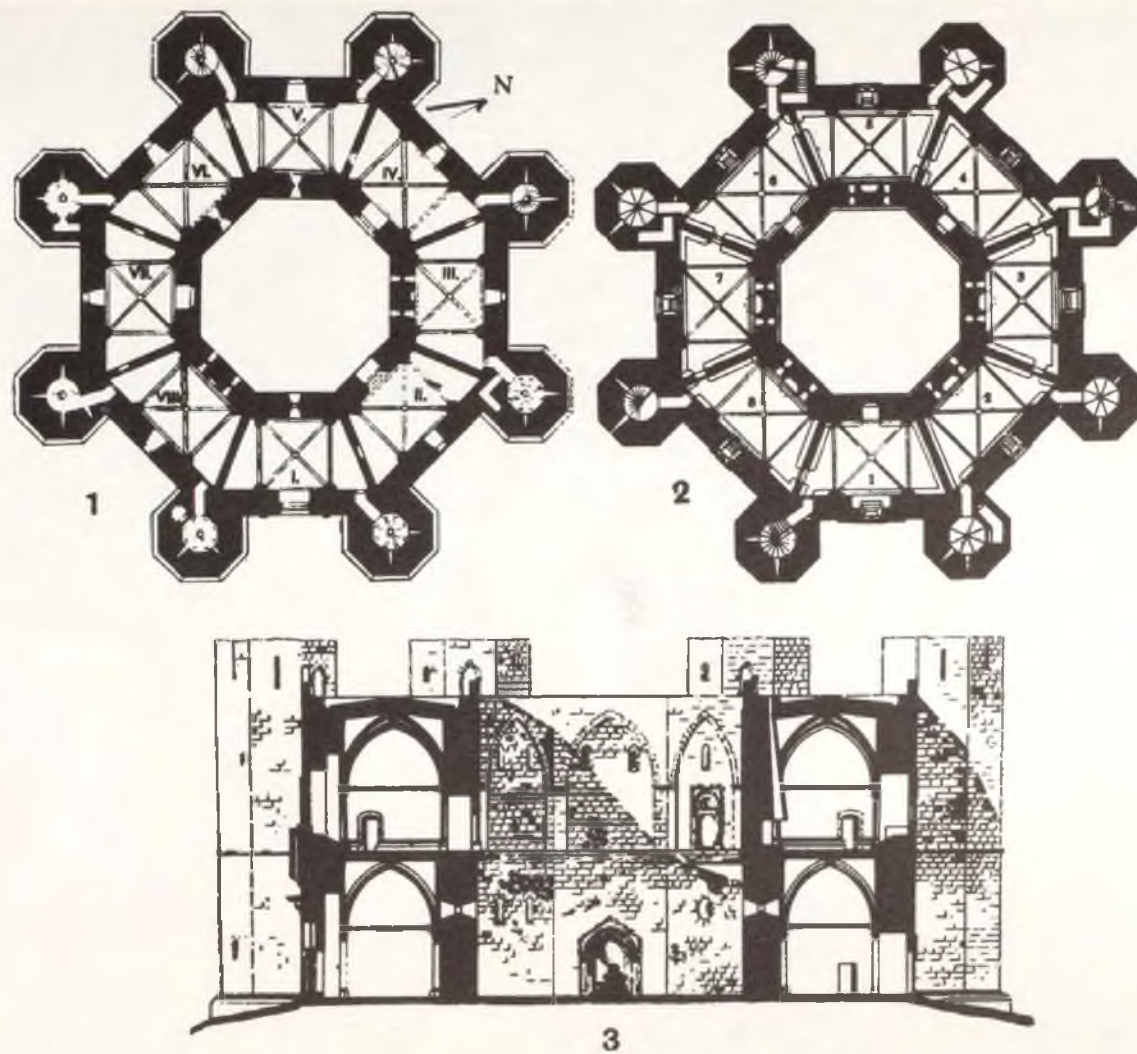

PLATE 30.—Plans and section of Castel del Monte (courtesy of Dr. Cresswell Shearer).
 1. Ground-floor plan. 2. Upper-floor plan. 3. Section.



PLATE 31.—The Castle of Lagopesole, one of Frederick's summer residences

views in all directions over the Tavoliere, and dominates the plain from Cerignola to Bari, and was fittingly called by the peasants "the spy" of Apulia.

The plan (it is unique) is that of a regular octagonal structure of two floors enclosing a small courtyard, with salient towers of the same shape at the corners. It was built throughout of a fine-grained stone resembling white marble, capable of taking a high polish. No wood was used in its construction except the doors, even the roof being stone-vaulted. There can be little doubt that the Emperor himself was the architect; for we find the same eight-sided towers in many of his other castles, as at Cosenza, Calabria, and Castrogiovanni, Sicily, as well as in his famous gateway at Capua. The top floor of his palace at Lucera also was eight-sided. It is, however, the conception of the building as a whole, its marvelous and perfect symmetry, and its unity of plan, combined with the masterly use of appropriate materials, that place it among the world's great buildings—in the small class that includes immortal creations like the Palazzo Strozzi, Brunelleschi's Chapel of the Pazzi, and Bramante's Tempietto.

It is of no great size, measuring only 180 feet in diameter from the corner of one tower to another, the courtyard being fifty-seven feet in width. There are eight rooms of moderate size on each floor;⁵ thus there was little accommodation for more than the Emperor's immediate attendants. In fact the castle was intended solely for his personal use as a hunting box, for his falconers and his birds, where he could forget affairs of state and devote his time to falconry. There is evidence that the tops of several of the towers were fitted up for housing his falcons, while other rooms

⁵ It follows from the geometrical plan of the castle that all its rooms are necessarily of the same size, measuring 36 by 19¾ feet. The second-story chambers, moreover, have their floor space further reduced by a marble seat projecting more than a foot from all four side walls.

formed columbaria or pigeon houses; for these birds formed a staple food resource in all medieval castles.

There was also an elaborate system of tanks in the towers where rainwater from the roof was caught and stored. Led down into the living quarters below by pipes in the walls, it was collected in a large cistern some twenty feet in depth beneath the floor of the courtyard. The center of this courtyard was occupied by an octagonal water basin (cut from a single block of stone), forming a fountain. This monolith has disappeared, but it was still in place at the end of the eighteenth century. A balcony ran around the courtyard at the level of the upper floor, probably for the convenience of attendants serving the various chambers. This structure also has disappeared, but one of the consoles that supported it is still in place. That the building was essentially a falconer's pleasure house is borne out by the fact that it was unprovided with a moat and drawbridge, being entered by a simple flight of twelve marble steps through a magnificent classical portal defended only by a portcullis. Its stout walls, seven and a half feet thick, have resisted the attacks of time for nearly seven hundred years, and are in places almost perfect. Many of the rooms have fireplaces, while the small tower chambers served as convenient dressing rooms, supplied with running water from the tanks above. Some of them are provided with washbasins and lavatories of an almost modern type, parts of which are still in position. The Emperor's bedroom on the upper floor (presumably Room 2², Fig. 2, Pl. 30) was appropriately furnished with two of these small retiring rooms. It was, however, the truly Oriental brilliancy of the interior decoration of the castle that must have filled the Emperor's guests with astonishment; the floors, the walls, the windows and doorjambs

⁶ In the plans of the castle, Roman numerals refer to ground-floor rooms, Arabic to upper-floor chambers.

were a blaze of highly polished, multicolored marbles and golden mosaics, the general effect of which must have been quite without parallel in Western art. If into these rooms we introduce a few figures of the Emperor's falconers dressed in all the radiance of their many-striped garments,⁷ we have indeed something worthy of the Arabian Nights' tales.

The ground-floor chambers are somewhat somber, lighted by rather small windows high on the outer walls but widely splayed internally. They were the quarters of the attendants, while the upper rooms were the living chambers proper. Only two of these ground-floor rooms were furnished with fireplaces,⁸ and these were undoubtedly kitchens, having square spaces probably formerly filled by small ovens built into the chimney flues for cooking food. The best-preserved room in the castle is one of these kitchens (Pl. 30, Fig. 1, Room VIII). It still retains part of its original mosaic pavement, and one of its corner towers has a spiral stair leading to the upper floor, while the other is fitted up with a sink and running water, evidently a wash-up scullery.

In making the round of the castle we notice that the usual precautions were taken—as was nearly always the case in all medieval buildings—of arranging the communications between one room and another in such a way as to make the sudden seizure of the castle by an enemy as difficult as possible. No two doors of an apartment were, as a rule, placed opposite one another; and different sets of offices never directly communicated.

On mounting the twelve entrance steps of the castle and passing through the main portal (with its portcullis), one enters a small entrance chamber with only one door (Pl. 30,

⁷ As depicted in the Vatican copy of the *De Arte Venandi cum Avibus*.

⁸ There are three fireplaces on the upper floor, making five for the whole castle. See also Plate 103.

Fig. 1, Room I). This leads into what was once an important room, evidently meant to impress the visitor with its elaborate door moldings and rich marbles of orange-red breccia (Pl. 30, Fig. 1, Room II). It was a waiting room or guardroom, having no further communication with the other apartments of the castle except through the courtyard. To reach the Emperor's living rooms on the upper floor it was necessary to cross the castle courtyard from this room, enter a second guardroom (Fig. 1, Room IV), cross this, and ascend by a spiral stair in the eastern corner tower and arrive finally in a third waiting chamber (Fig. 2, Room 4) on the upper floor, immediately adjoining the Emperor's reception or audience room (Fig. 2, Room 3; see Pl. 29). This last, with its magnificent triple-light window, was formerly the most richly decorated room of the castle. It had no communication with the towers. Today it is called the "Throne Room," although it is doubtful if the Emperor ever used the castle for the transaction of serious affairs of state—for we do not possess a single letter or document of the Emperor's that is dated from Castel del Monte.

The entrance to Room IV was undoubtedly the main route to the Emperor's private apartments; for over this door, under a marble baldachino, are the remains of a remarkably fine equestrian statue, probably that of the Emperor. The hood of the baldachino was cusped. The workmanship of the statue (in what remains of it) is astonishingly beautiful; the surfaces of the parts of the body and arms still in position are carved in clear imitation of the art of classical times. Frederick is represented as advancing on horseback, a veritable "triumphator," with a Roman *paludamentum* thrown round his shoulders, leaving most of his body exposed. Of further interest is the fact that the baldachino is of a type found only over the statues of saints and emperors in the

great Gothic cathedrals of France and particularly Germany. This type with a cusped canopy is seldom found in Italy, and is quite unknown in the South. Did the Emperor on his return from his eight years' stay in Germany bring with him northern craftsmen who worked for him at Castel del Monte?

It is possible to ascend by winding stairs from Rooms 1 and 4 to the roof of the castle, from which splendid views are obtained in all directions over the surrounding country. From this situation the visitor is even more impressed with the solitude of the castle, for he is disturbed only by the harsh cries of the falcons that circle ceaselessly round the building. Their nests continue to be built in the embrasures and crevices of the broken stonework. They seem to keep guard over the Emperor's great masterpiece; and who knows but these wild birds—the most important thirteenth-century occupants of the castle—may be a reincarnation of his undying will?

A long and vigorous controversy has been waged over the artistic influences revealed in Castel del Monte. It has been shown that certain of its features reappear on the famous baptistry pulpit of Nicola Pisano at Pisa, the admitted starting point (1266) of the Italian Renaissance in northern Italy. In documents dealing with this monument Nicola and his father are both mentioned with the cognomen *de Apulia*. Nicola, as a boy, may have worked for the Emperor at Castel del Monte. A beautiful head of classical workmanship, representing Bacchus crowned with vine leaves, forms the keystone of the vaulting in one of the ground-floor rooms and bears much resemblance to Nicola's craftsmanship.

The Emperor seems to have been a collector of antique sculpture. Still in place high on the wall of the courtyard of Castel del Monte is a fine Greco-Roman relief with figures in flowing drapery. In the course of the recent excavation at the bases of the

towers, parts of an exceptionally fine head (crowned with a chaplet of laurel or bay leaves) were brought to light. As it was found outside the castle, it may have been part of one of the busts that formerly decorated the gateway. Judged from what is left of the face it does not represent the Emperor, having sunken eyes and an expression much too mature. It may be a portrait of the Emperor's grandfather, Barbarossa.

In a recent restoration of the castle another bust has been found which seems to be that of a favorite falconer. Although it has suffered much damage and the face is badly disfigured, we can still make out that the hair is arranged in a thick roll at the back of the neck, and there seem to be traces of a tight-fitting cap that fastens under the chin with a strap. If this bust is compared with the figures of the falconers in the Vatican manuscript of the *De Arte Venandi*, the resemblance is striking. The face of the bust is broad and massive and, as far as any lineaments can be made out, it has a slight Arabic cast of feature. We know from the Emperor's letters that many of his falconers bore Saracenic names.

A third castle of the Emperor's, also intimately connected with his love of falconry, was that of Gioja del Colle (Jewel of the Hill), placed midway on the highroad connecting Bari with Taranto. According to Leandro Alberti⁹ it was built by Frederick. It is constructed in the usual Hohenstaufen manner, of rugged, rock-faced masonry, now turned a deep red by the hand of time. In the course of restorations carried out by its owner, the late Count Resta, some years before 1914, there were found astonishing quantities of the original Hohenstaufen decorations and furnishing of the castle, piled together in a great heap. These included all the parts of the Emperor's throne, now skillfully restored.

⁹ Leandro Alberti, *Descrittione di Tutta Italia* (Bologna, 1550), p. 218.

Internally the castle has been much altered at different times, so that it is difficult to be certain today of its original arrangement. The most remarkable room is the audience chamber, containing the Emperor's throne at one end. This throne is of interest for the unusual Sassanid (Persian) patterns carved on it, and for the fact that the back has a frieze of Iceland falcons cut in low

relief—a sad reminder of the Emperor's devotion to his favorite sport. In this room, guarded by his faithful Saracens, Frederick's body lay in state for the last time on Italian soil in the course of its journey from Fiorentino to the neighboring town of Taranto, where it was carried aboard ship and transported to Sicily for burial in the Cathedral at Palermo.



PLATE 32.—A falcon's nest with three eggs on one of the towers of Castel del Monte.
(Photograph taken through a window, by Dr. Shearer in 1938)



PLATE 33.—Near view of Castel del Monte, erected in 1240. The bare, stony character of the country is well seen in this picture. The masonry has suffered much from the rains and frosts of seven hundred years.



PLATE 34.—Bronze ram, from the entrance to the Emperor's castle at Syracuse, Sicily

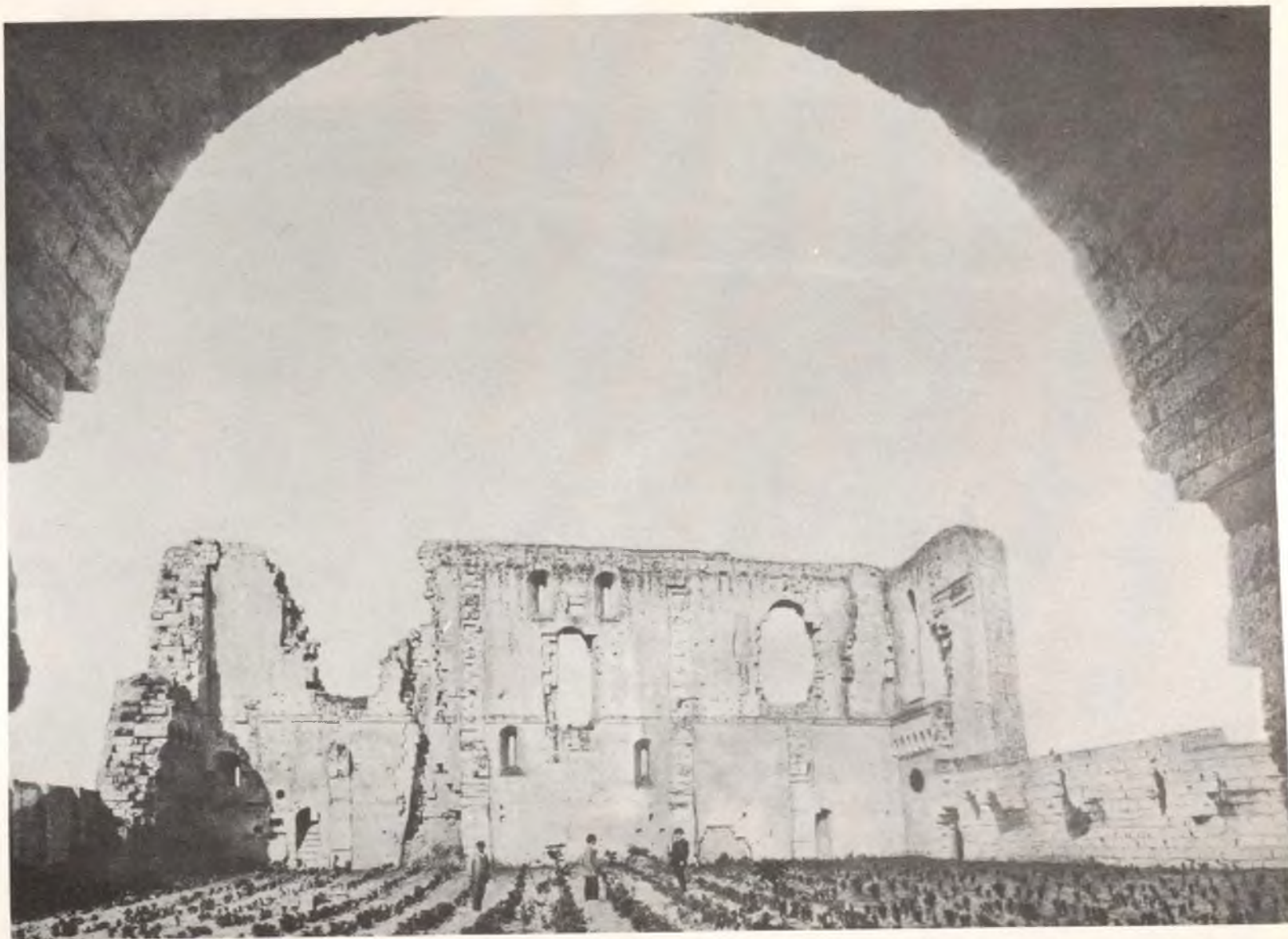

PLATE 35.—Remains of Frederick's "Parco per Uccellagione" at Gravina in Apulia, which was entirely devoted to the care and housing of his falcons
(Photo by courtesy of Dr. Cresswell Shearer)



The Art of Falconry

by

Emperor Frederick II
of Hohenstaufen







PLATE 36.—Three views of falconers and their charges, from the Vatican Codex of the *De Arte Venandi cum Avibus*: folio 74; folio 79; folio 76

GENERAL PROLOGUE

to the

De Arte Venandi Cum Avibus

by the

MOST NOBLE AND LEARNED EMPEROR

FREDERICK II'

YOUR urgent requests to undertake this present work, O most illustrious of men, M. E.,² prompts us to correct the many errors made by our predecessors who, when writing on the subject, degraded the noble art of falconry by slavishly copying the misleading and often insufficient statements to be found in the works of certain hackneyed authors. With the object of bequeathing it to posterity we now offer a true and careful account of these matters between the covers of this monograph.

We had proposed for a long time to present our theories in a work such as this, but deferred the task for nearly thirty years because we felt our insufficient experience and need of continued preparation. However, as time passed and we heard no report that any other writer had anticipated us and donated to the world a full account of such material

as we have been enabled to gather for the work, we finally decided to publish our own account of falconry. Certain branches of the art have, it is true, been explored by various other persons in the practice alone, and accounts thereof have been published, but with a lamentable want of mastery of the general topic.

We have investigated and studied with the greatest solicitude and in minute detail all that relates to this art, exercising both mind and body so that we might eventually be qualified to describe and interpret the fruits of knowledge acquired from our own experiences or gleaned from others. For example, we, at great expense, summoned from the four quarters of the earth masters in the practice of the art of falconry. We entertained these experts in our own domains, meantime seeking their opinions, weighing the importance of their knowledge, and endeavoring to retain in memory the more valuable of their words and deeds.

As the ruler of a large kingdom and an extensive empire we were very often hampered by arduous and intricate governmental duties, but despite these handicaps we did not lay aside our self-imposed task and were successful in committing to writing at the proper time the elements of the art. *Inter alia*, we discovered by hard-won experience that the deductions of Aristotle, whom we followed when

¹ In this English version of the *De Arte Venandi cum Avibus* the translators have followed the text and arrangement of the Bologna University MS. Lat. 419 (717), but have inserted in their proper places the additions and important emendations of King Manfred's work, i.e., the Vatican Codex, MS. Pal. Lat. 1071. In order to facilitate reference to the published editions of the *De Arte* we have preserved the chapter divisions of the Velsler edition in Books I and II. The chapter divisions of the last four books of the translation are our own and are based on the paragraph headings of the Bologna Codex.

² See the discussion of this "Dedication" on p. lxxxiii.

they appealed to our reason, were not entirely to be relied upon,³ more particularly in his descriptions of the characters of certain birds.

There is another reason why we do not follow implicitly the Prince of Philosophers: he was ignorant of the practice of falconry—an art which to us has ever been a pleasing occupation, and with the details of which we are well acquainted. In his work, the *Liber Animalium*, we find many quotations from other authors whose statements he did not verify and who, in their turn, were not speaking from experience. Entire conviction of the truth never follows mere hearsay.

The fact that many writers [on natural history] have written numerous works on diverse subjects with only a few scant references to falconry is, in our opinion, proof that the topic presents many phases that are difficult to discuss. We now offer the suggestion that those of our peers who have more leisure than we at their command and who are devotees of the art and find the present work an aid to its successful practice might well give us a complementary work clarifying such new and puzzling aspects of the subject as are continually arising in the practice of this gentle art.

We beg every nobleman who by reason of his rank should be interested in the contents of this work to order it read and explained to him by some master of the science. At the same time we crave indulgence for any ambiguity in our presentation of the subject. This art, like all other avocations, has its own peculiar vocabulary; and, inasmuch as the exact terms we require cannot be found in Latin grammars, we have substituted for them the terms that in our opinion best express our meaning.

Our main thesis, then, is *The Art of Falconry*; and this we have divided into two cardinal sections. The first contains the argument, by which we mean contemplative thought, or theory; the second illustrates practice, which portrays experimental action.

³ A not infrequent observation.

In addition, a third subsection contains a part of the argument and includes certain data pertaining to both theory and practice. Our purpose is to present the facts as we find them. Up to the present time the subject of falconry has been devoid of both artistic and scientific treatment.

The medium we have chosen for this monograph is prose, with prologue and text. The latter has many ramifications and analyses; among them will be found much descriptive matter, comparisons indicating similarities and differences, inquiries into causes, and numerous other lines of reasoning, all of which will be obvious to the reader.

The author of this treatise, the august Frederick II, Emperor of the Romans, King of Jerusalem and of Sicily, is a lover of wisdom with a philosophic and speculative mind.

The work called *The Art of Falconry* has manifold and far-reaching uses. The pursuit of falconry enables nobles and rulers disturbed and worried by the cares of state to find relief in the pleasures of the chase. The poor, as well as the less noble,⁴ by following this avocation may earn some of the necessities of life; and both classes will find in bird life attractive manifestations of the processes of nature. The whole subject of falconry falls within the realm of natural science, for it deals with the nature of bird life. It will be apparent, however, that certain theories derived from written sources are modified by the experiences set forth in this book.

The title of our work is: "The Book of the Divine Augustus, Frederick II, Emperor of the Romans, King of Jerusalem and Sicily, *De Arte Venandi cum Avibus*, an Analytical Inquiry into the Natural Phenomena Manifest in Hawking."

The subdivisions of the theme are clearly indicated; the Introduction precedes the text; generalities are discussed before taking up particulars, and natural phenomena are debated in their logical sequence.

⁴ The minor nobility.

BOOK I

THE STRUCTURE AND HABITS OF BIRDS

CHAPTER I

FALCONRY IS AN ART MORE NOBLE THAN OTHER FORMS OF HUNTING

SINCE falconry is undoubtedly a variety of the chase, and as the art of hunting has numerous branches, each with its peculiar practices, we might consider in what both the art of venery, with all its subdivisions, and the actual practice of hunting consist. Setting aside all else, we shall at the present time discourse mainly on falconry.

The art of hunting is the sum total¹ of experience by which men have learned to capture wild creatures of all sorts for their use by means either of force or of skill.

Hunting itself is nothing else but a form of bodily exercise and practices employed to capture animals. There are, in fact, three kinds of venery: that in which inanimate instruments are employed; that in which live animals are trained to catch other live animals; and that in which combinations of the first two are used.

The art of hunting with inanimate objects is a greatly diversified one and includes the employment of nets, snares, slings, bows, arrows, and numerous other instruments.

Examples of venery of the second class are seen in the use of such living animals as dogs, leopards, and other four-footed beasts, as well

as birds of prey. What birds are to be considered rapacious and what nonrapacious we shall shortly determine.

As we intend to confine the present work to hunting by means of birds, we shall now take up the employment for that purpose of trained raptorial birds and in this chapter give our reasons for believing it to be an occupation more worthy than other forms of hunting and explain why we select it for discussion.

There are many arguments that can be advanced to demonstrate the noble character of falconry, as the discriminating reader of this book will soon discover; and he will in this way learn more about the secrets of nature than if he followed other kinds of venery. It is true that the latter are more popular, because their technique is crude and easier to learn; falconry, on the other hand, is less familiar and does not commend itself to the majority because skill in it is difficult to acquire and because it is more refined.

Moreover, as regards other forms of hunting, which so many follow with enthusiasm, they are less noble because they depend merely upon the use of artificial implements, such as nets, snares, traps, hunting spears, javelins, bows, and slings, or they are carried on by means of four-footed animals, both tame and wild, such as various sorts of leopards, dogs, lynx (male and female), ferrets,² and other beasts.

On the other hand, the art of falconry is not

¹ *collectio documentorum.*

² *furectos.* Vide Martin, *The Record Interpreter.*

dependent upon such auxiliaries as artificial tools or four-footed animals but is almost entirely conducted with the aid of birds of prey that are indeed more noble instruments of the chase than inanimate objects or trained quadrupeds.

It is also true that it is far more difficult and requires more ingenuity³ to teach raptorial birds the stratagems of hawking than to instruct dogs or wild quadrupeds to hunt, because birds of prey are more afraid of man than are other birds or such four-footed animals as are used in the chase.

Moreover, raptorial species do not eat grain or similar food cultivated by man as do many other birds. As a result they do not associate with men and do not easily become domesticated. It is also well known that raptorial birds avoid man more than do other avian species and certain quadrupeds. Again, birds of prey frequent localities inhabited by man less than do the last-named animals. It may be added that wild and shy quadrupeds that shun mankind are difficult to tame and train for hunting and these difficulties are still more marked in the case of birds of prey. It is to be remembered, also, that the habitat of quadrupeds is limited to the earth's surface, their movements are not very rapid, and they generally run along in an upright position, whereas birds fly quickly through the air. Consequently the former are more easily brought under human subjection than are the latter, and they are readily caught by the use of force or are trapped by other means because they remain on the ground. Fully fledged birds, on the other hand, can be captured and trained only by finesse.

It is thus evident not only that the art of falconry presents greater difficulties but requires more unusual skill than do other forms of venery.

By means of this noble art most raptorial

³ *amplius difficultius et artificiosius.*

birds can be taught to hunt and capture even such birds as cranes, bustards,⁴ geese, and other large game birds⁵ that are bigger and heavier than those they capture alone in their wild state, as well as to take smaller quarry not only in their natural fashion but more often than is effected by other methods.

Although it is true that birds of prey display an inborn antipathy to the presence and company of mankind, yet by means of this noble art one may learn how to overcome this natural aversion, to win their confidence, and to induce them even to seek those they previously avoided.

By the proper exercise of falconry, raptorial birds are taught to tolerate the society of human individuals and their associates for hunting purposes, to fly after quarry, and to behave (without control) just as they would in their wild state. Any dabbler in venery can readily hold in leash or let loose dogs or other quadrupeds; but in the pursuit of falconry no tyro can so easily join in the chase, either to carry his birds or to throw them off at the quarry. Falcons and other hawks are rendered clumsy or entirely unmanageable if placed under control of an ignorant interloper. By using his hearing and eyesight alone an ignoramus may learn something about other kinds of hunting in a short time; but without an experienced teacher and frequent exercise of the art properly directed no one, noble or ignoble, can hope to gain in a short time an expert or even an ordinary knowledge of falconry.

Here it may again be claimed that, since many nobles and but few of the lower rank learn and carefully pursue this art, one may properly conclude that it is intrinsically an aristocratic sport; and one may once more add that it is nobler, more worthy than, and superior to other kinds of venery.

⁴ The manuscript, reading *bistardes*, is wrongly reported as *sistaroas* by Velser (p. 7); the latter was followed by Schneider, who defines *sistaroas* as "a big bird"!

⁵ *majores alterius maneriei.*

Let it then be the first one discussed. To other forms of venery, especially those patronized by the nobility, we shall return (our life being spared) when we have completed this present treatise.

CHAPTER II

OF THE DIVISION OF BIRDS INTO WATERFOWL, LAND BIRDS, AND NEUTRAL BIRDS

In this first section of our work we shall discuss those aspects of bird life it is necessary to understand before investigating the art of falconry. Birds, like all other animals, may be divided into various species in accordance with their sexual relations, their parturition, their methods of procuring food, their variations in residence at different seasons of the year (chiefly as a result of alterations in temperature), and their change in diet.¹

Consider, then, a general division of birds based on the different activities they employ in securing food, the great varieties of that food, the flights they make to localities both near and far in search of heat or cold, the variety of and support given them by their limbs, the peculiarities of their feathers, their art of flying, their contests, and their moulting. It is, therefore, quite obvious, in so far as our plan permits, that we, as practitioners of falconry who hunt with birds of prey, should discuss these avian traits so that we can better understand where, when, and how hunting birds can be taught to catch their prey. All that we do not include on the nature of birds can be found in Aristotle's book *On Animals*.

All birds may be divided as follows:

Waterfowl are birds that habitually live in or near aquatic areas and whose organs are so fashioned that they may remain for indefinite periods immersed in water.

Land birds are those that prefer a continuous life on land, an existence for which their bodies are especially constructed.

Neutral birds are those that may change from one habitat to another, from earth to water and vice versa, as shown both by their preferences and by their bodily structure.

Although Aristotle declares that every creature may be classed either as a water resident or as a terrestrial animal, and that only fish are truly aquatic, and includes under the term of land animals all those that progress both by walking and by flying, yet he does not make the mistake of classifying all winged creatures as birds. We, however, following the usage of falconry experts and adopting its terms, divide birds (in whose mingled constituents the lightest of elements predominate and who are the lightest and most agile of the winged inhabitants of the air) into water, land, and neutral birds; and of all these we shall give examples. We find that they may also be divided into various genera and these again into a number of species.

Water birds rarely leave and prefer to remain in the water.² They do not leave it in search of food or for other purposes except when they fly from one body of water to another or during their seasonal migrations. These species include mergansers, cormorants, swans, and those birds that Aristotle in his *Natural History* calls pelicans and which the Apulians dub "cofani."³ The last-named are as large and almost as white as swans; they have a long, broad beak that has a pouch attached that they open and shut like a fish-

² The mergansers make use of tall trees and terrestrial nests in which to raise their young: at any rate they prefer the land for this purpose. As for cormorants, their nests are found on trees or cliffs. Swans patronize islands and often make floating nests. Pelicans nest in canebrakes or among reeds. All the birds mentioned by Frederick II leave the water for various purposes.

³ One is struck by the evident reference to the pelican's pouch. It. *cofano*, a basket or small trunk; Lat. *cophinus*; Gr. κόφινος. See Book I, chapter xxxiv, p. 74.

¹ This is largely Aristotelian, or Stagirite, doctrine.

net.⁴ They also have a [swimming] web between their feet that extends to the hind toe; the latter condition is not found in other waterfowl with webbed feet.⁵

These and many others rarely leave aquatic areas. Others occasionally do so for the reasons aforementioned, as well as in search of food, and then return to it according to their natural impulses. This is the rule with some species of geese, ducks, and similar birds. Certain land birds visit bodies of water, but only for drinking and bathing, among them quail, partridge, pheasants, [common] bustards, and lesser bustards⁶ (that are like the former only much smaller). To this class belong also peacocks and birds like them.

Certain birds live most of the time on land but resort to water not only for drinking and bathing but also to secure their food, like aquatic fowl, returning to the land for rest. These include the sea eagles, which dive into the sea, rivers, and swamps to catch fish, after which they return to the cliffs and trees where they dwell. It is proper to class them with land birds because they are birds of prey and as such ought not to be called waterfowl.

Of neutral birds one may distinguish three types. Some of them (like the curlew) prefer water to land, in response to the demands of their bodily structure. Then there are others that have a changeable residence but seem to prefer land to water, such as plover, lapwings, and snipe. Of these, plover love the water

less than lapwings, and lapwings more than snipe. The latter more nearly approach the character of land birds than lapwings or plover, because, though both these birds often sleep on land, snipe slumber there more frequently. There are still other birds that remain as much in the water as on land, like the cranes, both large and small,⁷ also both kinds of storks, the white and the black. The latter are frequently seen wandering about, fishing in water and in swamps and other wet places, returning afterward to dry land.

Into these three classes (land, water, and neutral) are all birds divided.

It may be added that those neutral birds who spend the greater part of the time in the water are customarily called waterfowl by bird hunters and these as well as true aquatics are termed shore birds.⁸ Those neutral birds that follow their natural bent and live mostly on land are often called terrestrial; and both these and land birds may be styled field birds, or birds of the plain. Some of those species that live equally on land and water may be termed either land birds or water birds; but those neutrals that come twice a day to feed on dry land but return each time to an aqueous resort for safety and rest, although they frequent the meadows, are nevertheless to be classed as aquatic birds, since they most resemble true waterfowl in their habits and seek the water as a permanent place of refuge. Among such birds are the cranes. Those neutral birds, however, such as snipe, plover, and lapwings, that live in meadows but go to bathe and drink in the water and take refuge there when pursued by birds of prey, may well be called land birds; for, as will be observed in

⁴ The common white pelican, *Pelicanus onocrotalus*, changes from brownish to a light rose color after its third year, and looks white at a distance, especially when old and just before moulting.

⁵ The same palmated formations seen in pelicans occur also in common cormorants, darters, gannets, tropic birds, and frigate birds, that constitute a separate subgenus of *palmipeds* or web-footed birds.

⁶ The little or lesser bustard (*Otis tetrax*) is common enough in the Far East and in Southern and Southeastern Europe but is rare in the North. Frederick II gives these birds a nickname—*Anotes quae dicuntur campestris, quae similis sunt bistardis*—bustards being called by him *bistardae*.

⁷ Probably the "small" cranes were the young of adult birds and wore their nestling garb. They associated with older individuals; or they may have been "demoiselle cranes" (*Anthropoides virgo*) that occasionally visited Italy and are certainly smaller and more delicate than the common crane (*Grus cinerea*).

⁸ *aves de riviera*.

the chapter on bird defense, many land birds take to the water when chased by their raptorial foes, for example, the crows.

CHAPTER III

OF THE DIVISION OF BIRDS INTO RAPTORIAL AND NONRAPTORIAL SPECIES

Birds may be classified in still another manner—as raptorial and nonraptorial species.¹ We call raptorial all those birds who, employing their powerful flight and the special fitness of their members, prey upon any other bird or beast they are able to hold and whose sole sustenance is the flesh of such animals. These are the eagles, hawks, owls, falcons, and other similar genera. They feed only on their prey—never upon dead flesh or carrion (*carnibus cadaverum neque residuis*)—and are therefore called rapacious birds. Aristotle calls them “greedy-clawed” birds or sometimes “birds of the hooked claws”;² but this nomenclature seems to us unsuitable, since it is erroneous in so far as birds such as jackdaws, the larger swallows, and vultures have hooked claws and yet may not properly be called raptors, as they do not feed upon their own quarry.

[It was the habit of Aristotle and the philosophers to classify objects into positive and negative groups and to begin their discussions with the positive. Since it is our purpose to give special attention to raptorials, we shall first consider the nonrapacious (or negative) varieties; afterward we shall consider at length raptorial birds.]³

¹ The remainder of this paragraph (given here as it appears in the Bologna MS.) is missing entirely from the Vatican Codex. In its place there has been substituted the next paragraph (placed in brackets) which does not appear in the Bologna MS.

² *aves unguis rapaces et aliquando aves uncorum unguium*. Bologna MS., fol. 3.

³ Vatican Codex, fol. 4^v, col. 2. See footnote 1, above.

Nonraptorial species are those (whether aquatic, land, or neutral birds) that do not live entirely by robbery; in fact they cannot be regarded as true birds of prey if they subsist in part by plunder and partly on grains and fruit, like some ravens, crows, and magpies—less frequently certain species of vultures, and the so-called “bone-breakers” (*lammergeiers*)—also some ignoble eagles⁴ that never plunder other birds or quadrupeds but feed on dead bodies and scraps.

It is,⁵ therefore, evident that all birds may be included under the two categories of rapacious and nonrapacious, and that birds of prey differ from harmless species not only in their method of securing food, as is herein described, but also in many other ways, as, for example, in the form of their members, in their behavior, and in the thickness or sparseness of their plumage.

Among the characteristic forms of their organs may be mentioned: the beak, which in birds of prey is generally curved, strong, hard, and sharp; claws that are bent inward and are hard and needle-pointed; retracted eyes;⁶ a short neck, short legs, and the posterior toe of each foot very strong. The female is larger than the male. Not all of the foregoing is true of nonraptorial birds.

Functionally also they differ in that raptorials are more keen-sighted and have more acute hearing than other birds. They are strong in flight but walk badly. They dislike water and drink little, fly alone, and live long. They drive their young early from the nest and then abandon them; and this behavior is not that of nonrapacious birds.

⁴ *modus aquilarum ignobilium*, probably vultures other than the *Geier*. Schöpffer remarks that all the German eagles are predatory, and, although they do not eat carrion, they rob other birds.

⁵ The text from here to the sentences beginning “It is also to be noted,” on page 10, is entirely lacking in the Vatican Codex at fol. 4^v, col. 2, l. 30. It is found in the Bologna MS., from fol. 3^v, col. 1, l. 7, to col. 2, l. 31.

⁶ *oculos concavos*.

As to plumage, it varies among raptores; the first year after hatching (when they are called sorehawks [*saure*]) they moult only once, while other birds (generally) shed their feathers twice. The large quill feathers of the wings and tail are limited to a definite number; this is not true of other birds.

In numbers also the two classes differ, for there are fewer rapacious birds than nonrapacious; and there are no raptores among aquatic and neutral birds, but only among land birds, and even here they are few in number; so that all water and neutral birds and the greater part of land birds are nonrapacious.

Rapacious birds (which are universally warmer and drier than aquatics and neutrals) dislike water for two reasons, one active and the other passive. Since they have not members and plumage of a suitable form, they do not live in the water, nor can they do so, because they cannot continue to stand in deep water, lacking long legs like those of herons and cranes, nor can they swim about with ease, as their feet and toes are not webbed like those of geese, ducks, coots, and nearly all aquatic birds. Were a raptorial bird overturned, or submerged, in water her feathers and quills would be more inclined than those of aquatic birds to become soaked, so that she could hardly fly, and her claws would become so softened that she would be unable to wound or hold her prey. For these reasons, birds of prey dread remaining in the water, since they are extremely feeble in that element. There are certain birds, however, similar to eagles but smaller, that perch above bodies of water (or on high banks) and, when they perceive fish in the water, suddenly drop on them, draw them out alive, and feed on them. They are, therefore, called fish eagles. Their members and plumage are better adapted for this purpose than are those of other raptores.

The genera into which raptores are divided, and the species in each genus, will be

discussed more fully in another treatise⁷ and in other parts of this work.⁸ It is also to be noted that the same genera and species are given different names by diverse authors. Sometimes the same bird may have a variety of synonyms; and the same name applied to diverse birds that are so dissimilar that one cannot establish the true identity of a species simply by its name. In consequence of this multiplicity of terms, a description of the essential characters of individual birds is more difficult to furnish, whether they resemble or are different from another in the shape of the limbs, the movements they make, the way they feed, the care of their young, their mode of flight, and their style of defense.⁹ Let it, however, be remembered that, in general, their bodily conditions and their other peculiarities are due to definite causes.

Very different localities may possess the same species and genera not found elsewhere; or a single region may be the habitat of birds of a species found nowhere else; while, on the other hand, in one region may be seen a genus found elsewhere but of a different color, or varying in other respects, but which may be identified by the characters of its members, its feeding habits, and other essentials. Therefore when we give one example of a genus and speak of others as similar, it is not necessary to repeat all the identification marks, lest we be guilty of tiresome prolixity. Indeed there is a multitude of birds, aquatic, terrestrial, and neutral; and so many genera are in each class that it would take too long even to mention them. However, when birds presenting essentially the same (or entirely different) characteristics are encountered, they may be described as

⁷ Probably in the work on hawks that was often promised but was presumably never written. Cf. Schneider, pp. 75, 89, and 92.

⁸ At this point ends the passage missing in the Vatican Codex.

⁹ A difficulty not confined to medieval ornithology.

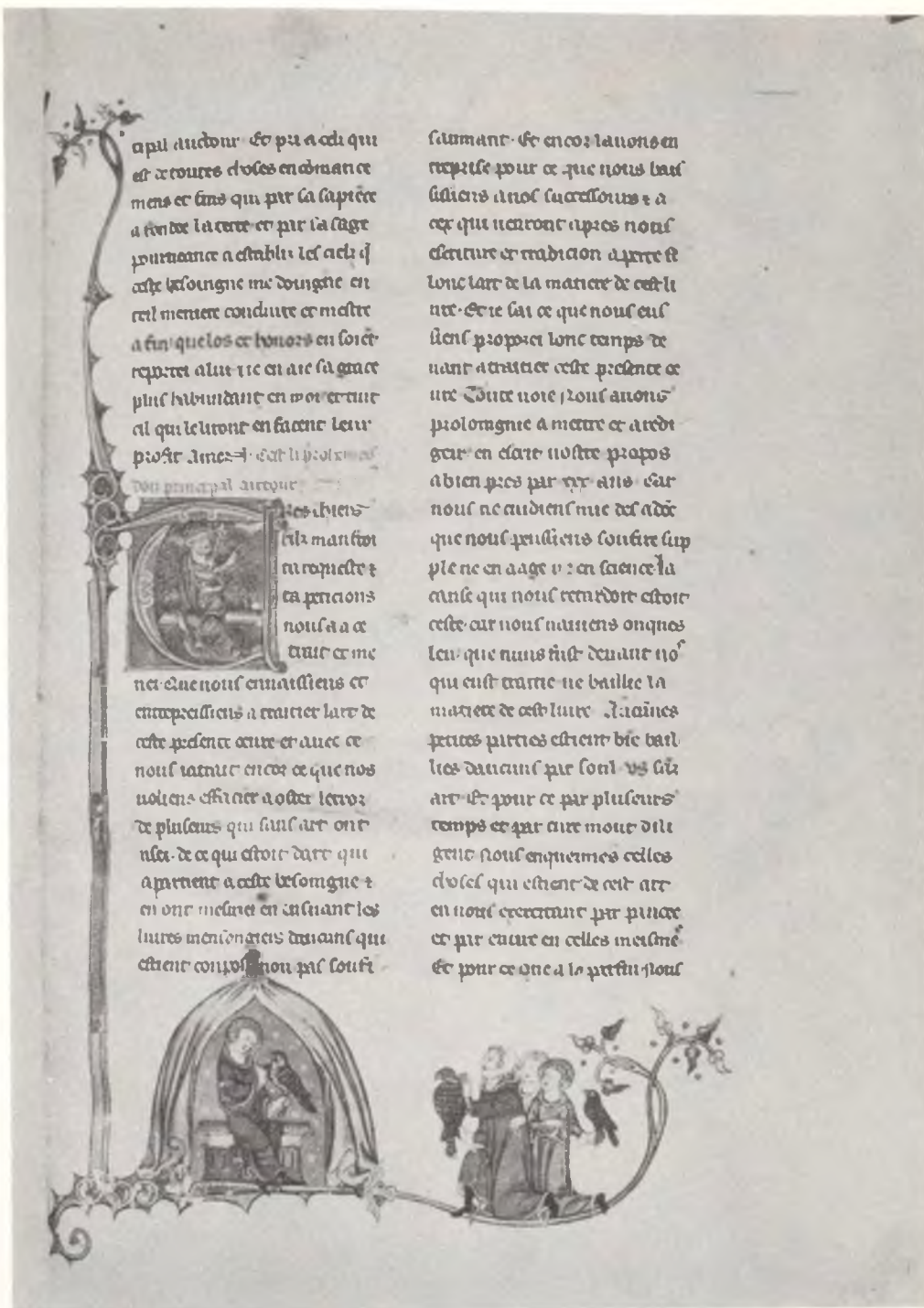

PLATE 37.—Folio 2 of the French translation of the *De Arte Venandi cum Avibus* (Bibliothèque Nationale MS. Fr. 12400). The two portraits in this miniature should be compared with those of Plate 3 (p. xxxi). Note the difference in the ages of the figures.



beste uolable et qui n'a par
 sus terre. Ne ne dit mie que con
 ce beste uolant soit oiseau.
 Toute noie par aucune a coul
 tumance que nous auons eue
 entre la chace des oiseaux. p
 aucune transsumption de par
 ler. nous auons eue entre
 les a quatriques et reueltes.
 les moens oiseaux. li quel se
 plus legier plus souuent me
 uent et demeure en l'air
 et ont signe en la queue
 on de lor matiere les hautes
 choses et les dantes des lig
 ces demant de roucel oel ch
 sel d'orons nous exemple en
 pour leuant l'admission des
 selonc loz diuices menieres
 et selonc loz diuices sembla
 ces. Des oiseaux de haue. Le
 demurent touz loz et i'auos
 qui ne ce departent pour ne
 pour uant ne pour autre
 chose. aus que rancque au
 cune fois elles se muent du
 ne paue en autre ou pour ce
 quelles muent loz leuz selonc

la mutation des tens. Ains
 con sont une meniere de haue
 et coibiaus de mer qui sont
 a pelet pluon et signe. et cil q
 Aristotes a pelet en luy des bel
 ces pellicans qui en puelle soe
 a pelet coillon. se sont oisels gris
 et blanc en la meure de rig
 des elles ont lonc et large bec
 de lor. le quel elles ont une pe
 lette qu'elles occurent et doent
 en pechant en meniere de aal
 se et ont dois de piez touz au
 tier. et li curs q'mue le doi dar
 tier as dois demantiers la que
 chose nauent point as autres
 oiseaux qui ont les piez heur
 aut. et li autre pou ou
 niant se departent des i'auos.
 li autre sont pas touz loz
 mansion ens i'auos. mais se
 departent pour les deuz. et
 desus d'icez cest a sauoir pour
 aller d'une paue en autre. p
 muer loz. et selonc la muta
 non de tens et en coe sen depur
 tent pour querir loz. uant
 et pour ce que loz nature te

PLATE 38.—Folio 6^r of Bibliothèque Nationale MS. Fr. 12400. To be compared with Plate 39. Note that, though the arrangement differs, the same birds are portrayed.



PLATE 39.—Folio 4^r of Vatican MS. Pal. Lat. 1071. Note the accurate drawing and close attention to detail of the various avian species, evidencing a more than common knowledge of the subject portrayed. Compare with Plate 38.

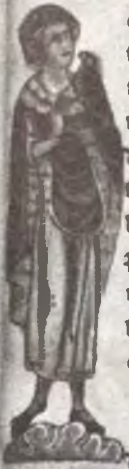

noer que pour aler et a bien
pres cur li oisel noant so-
ent de aiant qui bien volent
ou de aiant qui mal volent
sont de mauvais gres et de
petite cete

La
cause pour coi li oisel noant
sont de petite cete et de mau-
vais gres est car o celle me-
me doisiant soit nee et or
donnee a noer pour a querre
son uivre en noant nature
lor a donnees iambes courtes
pour ce que miez et plus fer-
ment et plus legierement el-
les hument les faues en no-
ant car celles cassent long-
ues iambes il lor fait trop
grief a harter que liane con-
de necessite il couvent li
iambes pour lor longuete
trop parfondement les fait
es labe enner et profundar
Et com les faues soient men-
es plus legierement on par-
fondelles pour ce quelles soit
plus long de leir elle fait
moins de resistance car on

parfont elle mesmes se moine
et gouerne et en la face par
dessus par la traction et a tou-
che de l'air par le quel liane est
demence elle soustient le cors
noant et com il couaigne q
ti d'ores soient menes en no-
ant par sul la face de liane
est a sauoir elle mesmes li-
ane et li ars qui li est couoms
et mis deuant facent plus gief
resistance al piez de l'oiseil noant
en conduisant et esdant p
durer lor piez en liane a recu-
lent et par deher pour miez
hurter li oisiant al anoir lo-
gues iambes en lor menant p
le parfont des iambes il ne por-
tent pas faue real tout ne real
impulsion car il ne troueront
pas li grant resistance on par-
font com il sont par les cour-
tes iambes qui sont menes p
sul la face de liane la quelle lor
ait miez a la impulsion et a
lor tout de ce uoient nous ex-
ample as galies car que le
gouuernour et li natmer vel



PLATE 40.—King Manfred portrayed (above) as a falconer (Bibliothèque Nationale MS. Fr. 12400). Note the marked alteration in style (when compared with Plate 5) (p. xxxiii), combined with complete fidelity of subject matter. Note also the addition of the mast and sail, as well as a third figure, to the boat.

belonging to the same or to a different genus, and this will be true even of birds not seen elsewhere and not previously identified.

CHAPTER IV

OF WATERFOWL: WHEN AND HOW THEY SEEK THEIR FOOD

In addition to the foregoing observations let us consider how aquatic birds secure their food. Their movements and methods are not alike in all instances because some of them swim well but fly with difficulty and, consequently, do not wander far from the water. This is specially true of cormorants but is not in agreement with the teaching of Aristotle, that those birds that are limited in flight are to an equal extent good pedestrians. Cormorants, it is true, do not fly with ease; yet they walk still worse. When applied to land birds this rule may in many instances hold good, but in the case of waterfowl with a limited flight range these swimmers have legs ill-adapted to walking, whether they fly well or badly.

[Addition by King Manfred:¹

The reason swimming birds have defective walking powers is that by nature their livelihood depends upon their ability to swim well, and for this purpose they have crooked tibiae, in consequence of which they move about better, with greater force and more ease, in the water. If they had long, straight tibiae it would be difficult for them to swim well, as their feet would extend too deep into the water—to levels that, lying relatively far from the air, are easily displaced and furnish little resistance, for one medium only is affected, namely, water at a low level. But near the surface, owing to the attraction of the air, the water offers resistance and the

body of the swimmer is better sustained; for it stands to reason that where two media, such as air and water, are in contact and opposed to each other they produce greater tension and better resistance to the extended feet of the swimmer, whose body is therefore more strongly propelled. Were these birds furnished with long legs, they would be unable to gain (through their movements in deep water, where there is little resistance) such a rapid forward motion as they are able to attain on the surface by means of their short tibiae. We have an illustration of this truth in the case of galleys. When their rowers wish to make speed they do not immerse their oars deep in the water but dip them on the surface. There is an additional reason for the swimming bird's short legs; if it were obliged, in order to make progress, to stretch long limbs backward, greater effort would be required to draw them in for a fresh propelling motion than is the case with short tibiae that are easily and quickly maneuvered. Nature has therefore provided this class of aquatic birds with short legs to facilitate swimming; but since such limbs render walking more difficult, as one sees in the case of dwarfs, it follows that these waterfowl are poor pedestrians.]²

Certain water birds both swim and fly well, yet they rarely leave the water; for example, swans, pelicans (called in Italy *cofani*), cormorants, and their relatives. Other birds, like water rails and their kin, do not swim or fly well, although they are true aquatic fowl. Others, e.g., the heron, cannot swim well but are good fliers, yet they do not wander far from wet localities.

Some waterfowl dive entirely under water to obtain their food; others immerse only the head and neck to the shoulders or to the middle of the body. Their food consists either entirely of aquatic produce, or it grows

¹ This passage, taken from the Vatican Codex, fol. 5^v, col. 1, to fol. 6, col. 1, is missing from the Bologna Codex.

² Here ends the passage by King Manfred, taken from the Vatican Codex.

on land alone, or it may be derived from both these sources. Pelicans, cormorants, and mergansers live exclusively on fish.

Aquatic birds that subsist on terrestrial products only seek their food in or near the water, like swans who feed on herbs, grains, and fruit that, owing to the weakness of their bills, they are obliged first to soften in water before they can swallow them. Others secure their food near or far from water, wherever they can most easily obtain it, like geese, that consume herbage in either planted fields or meadows. As regards those waterfowl that eat both aquatic and land products, some devour fish as well as terrestrial animals and aquatic reptiles. This is true of herons, who do not despise fish, frogs, snakes, or mice. Ducks may devour fish, herbage, fruit, and grains. From the foregoing it is clear that some swimming birds live on fish, like the divers, pelicans, and cormorants; others (the swans for example) reject these foods; while still other birds, who live on fish, like herons and their kindred, are not swimmers. Many others, such as the oyster catchers (or sea pie),³ are waterfowl that neither swim well nor eat fish.

CHAPTER V

OF THE EXODUS OF WATERFOWL TO THEIR FEEDING GROUNDS

Now that we have discussed the variety of food consumed by waterfowl, we must explain at what hours they set out to feed (that is, those that leave the water for that purpose); how often this departure occurs during the day; in what manner they fly to the feeding place; how they pass the intervening time and how they return home; in what order they fly back; what localities they visit; what decides them when to return to their aquatic resorts; and exactly how, mean-

³ *Modi picarum quae sunt aquaticae.*

time, they rest on the surface of the water itself.

With very few exceptions the exit of water birds from their usual resorts in search of food takes place during the daytime. Only those with moderate powers of movement and slight ability to fly, such as cormorants and coots, make this journey by night, and then solely because of their fear of birds of prey.¹

The return of aquatic birds from their hunting grounds is fairly definite; as a rule they leave home at sunrise and remain in their feeding resorts until the third hour,² sometimes earlier, sometimes later, sooner if it is a hot day, later if it is cloudy and cool. In some instances they rest on the home water until about the ninth hour,³ going out again to feed until sunset warns them to leave for a night's rest. These hours may vary with changes in temperature. Some birds, geese for example, pass the night away from their home resort (especially during moonlight), when they consume large quantities of herbage, which is collected by the aid of the moon when the nights are long, short days being insufficient to allow gathering a sufficient food supply.

It sometimes happens that flocks of both large and small geese, as they fly to and from their feeding grounds, are accompanied by domesticated individuals. Wild geese rarely become tame. Only a few tame geese continue as such; the majority eventually revert to the wild state, as it is more natural for them to follow their normal instincts despite any advantages gained by domesticity.

¹ Here Schöpffer says that cormorants and coots (*Fulica atra*) exchange resting places more by day than by night because they must see the fish upon which they rely for food. It is the ebb and flow of the tide that mostly regulates the coming and going of waterfowl, and this is pretty regular. He quotes Ferdinand von Droste's *Vogelwelt d. Insel Borkum* in support of this statement.

² About nine o'clock in the morning.

³ Three o'clock in the afternoon.

Other waterfowl and neutral birds do not leave their usual resting places during the night. They are generally those birds that feed on grain and roots which they cannot see at night even by the help of the clearest moonlight. Such are plover, lapwings, and cranes.⁴

Ducks, teal, and similar birds do not limit their hunt for food to any particular time but feed at all hours in and out of the water.

From the foregoing facts we may divide the bird's day into three spells, of which two are spent in their feeding grounds and the third in resting in their permanent resorts. They spend the entire night in repose upon the water; thence they make two journeys to and from the feeding grounds.

The manner of their departure from and their return to a habitat varies greatly. Many birds, when leaving a locality, join with others of the same species to form flocks that come back in the same order they left, that is, in two lines that form an angle. Seldom or never do we see among their number any individuals not of the same species; that is to say, geese always accompany geese, ducks flock with ducks, teal with teal, cranes with cranes, etc. [If by any chance these birds happen to mingle, they do it because they see others about to fly and are taken with a desire to be on the move; but they soon separate and rejoin their fellows.]⁵ There are, however, birds (lapwings, for example) that do not adopt any particular order in this flight but go and come as a medley, sometimes in

⁴ Schöpffer draws attention to the fact that the two first-named birds do not prefer "grains and roots" but subsist chiefly on "animal" food, meaning (we presume) mainly insects and worms. On brightly illuminated nights they are quite lively and go about hunting this sort of prey.

⁵ Not in the Bologna MS.; cf. Vatican Codex, fol. 7, col. 2. It is probably a short, unmarked addition by King Manfred.

⁶ That is, they swallow it whole and digest it afterward.

groups, sometimes singly. Such birds, both neutrals and land species that are not raptorial, eat greedily, swallow their food quickly and as they find it.⁶ They are not obliged in any fashion to prepare it in advance, whether it be grains, fish, winged or wingless insects, or worms. They eat in this manner because, were other birds living on the same food to see it, the latter would have no time to approach before it was safely swallowed; nor do such birds like to eat alone, but prefer to fly in flocks and to feed in the company of their own kind.

CHAPTER VI

OF THE ORDER IN WHICH BIRDS DEPART FOR THEIR FEEDING GROUNDS

Waterfowl and neutrals leave the water and fly to their feeding localities (as a rule) in the following order: First come the lesser geese, then the cranes, then the larger geese; [last of all fly the bernacles¹ and certain smaller kinds of geese that fly with them, called *blenectae*.²]³ After these geese come the other aquatic birds.

Their return occurs in the following order: the first to leave and plunge into their home waters are the bernacles and teal (*blenectae*), followed by the cranes and geese, and finally the remaining flocks.

The localities they choose for feeding vary greatly according to the character of the food, the season of the year, and the ease (or difficulty) of escape from birds of prey. Ducks and related species prefer pasturage during

¹ Improperly called "barnacle." See *Oxford English Dictionary*.

² Perhaps teal. Du Cange says only *Blenectae speciei quaedam anserum parvum apud Fridericum II*, thus throwing no light on what "little geese" the author had in mind.

³ This short passage appears only in the Vatican Codex, fol. 7, col. 1.

the wet season and particularly during the rainy days of September, October, and November. This period is chosen mainly because at that time the rain dislodges the seeds of plants, fruits of trees and shrubs, which the waters collect and carry to rivulets, the shores of streams, and other shallow collecting grounds where the birds congregate. These are the occasions and places they prefer and most often take advantage of to feed. Moreover, not only ducks and other water birds frequent these areas but also those that live on worms, which they dig out of the earth or find on the ground. It is mostly during the rainy season that in such places worms abound. Abandoning their burrows⁴ most vermes come to the surface to escape water, which is noxious to them. Also at that time, because of the water-softened top soil, it is easier for these creeping animals to come up than to dig deeper where the earth is hard.

CHAPTER VII

OF THE RETURN OF AQUATIC BIRDS TO THEIR WATER OR SWAMP REFUGES

The home localities to which waterfowl return may be lakes, ponds, swamps, or some of the longer or smaller streams, and other water-covered areas sometimes called flats;¹ but they prefer to swim about and plunge into some rocky and extensive body of water possessing islands and other advantages. Their home-coming takes place during the day, that they may guard against such wild animals as fish otters,² foxes, and birds of

⁴ *habitaculis.*

¹ *et cetera loca una collective aquarum quae dicuntur a quibusdam placere.* The word *una* is probably an error and may well be intended for *ima*.

² Schöpffer properly says that the fish otter (*Entra vulgaris*) may now and then catch birds for food but

prey. The last-named do not pursue waterfowl very much in the water, because swimmers can easily escape from them by diving. Even weak waterfowl more successfully defend themselves in this way than many other stronger birds that live away from water. Aquatic birds³ return to the water in the daytime for the purpose also of drinking and resting. This is especially true in summer. At night they remain standing in the water not only for protection against otters, foxes, wolves, and other wild animals that may harm them while sleeping but also that they may pass the night in peace, sleeping and resting.

CHAPTER VIII

OF THE POSITIONS ASSUMED BY BIRDS WHEN ASLEEP OR AWAKE ON OR IN THE WATER

During sleep swimming birds pass part of the time floating on the water, part of it near the shore with one or both feet on the bottom. Nonswimmers, aquatic birds or neutrals, keep either both feet on the ground under the water, or rest on one foot with the water up to the knee or above that point, depending upon its depth.

The larger number of water birds, like some land birds, when sleeping, turn round the head and rest it on the back between their shoulders. Indeed both swimmers and nonswimmers usually sleep on one foot, holding their heads on their backs below the shoulders so that the head as well as the cold and horny beak may be kept warm. This position not only provides warmth but prevents wetting the head (keeps it dry) and

only when very hungry and unable to secure his proper food, viz., fish.

³ The text to the end of this chapter, missing in the Vatican Codex, is from Bologna MS., fol. 5, col. 2.

thus avoids possible freezing of the parts in very cold weather. Disease in the head, called *gipsus*,¹ may easily set in from exposure to wet and cold.

Not only waterfowl but almost all other birds sleep on one foot in order that they may sleep lightly and be easily alarmed and readily awakened to meet approaching danger. Water birds asleep with one foot in the water readily sense any disturbance of the surrounding fluid and are thus warned of the approach of beasts of prey or other enemies. Since² water is liquid and its limits are ill-defined, it recedes from the point of disturbance with a circular motion that extends to the leg of the bird, who, feeling the motion, is instantly alarmed and put on guard. Moreover, a body that has several points of support stands more firmly and is more difficult to move than one resting less securely. Hence a bird resting on one foot only is easily roused. This, added to the fact that any person sleeping under threat of danger is easily disturbed, makes it doubly plausible that birds sleeping normally under these conditions will be quickly awakened.

[Addition by King Manfred:³

There are other reasons for the foregoing which Manfred, former King of Sicily, son of the divine, august, and imperial author of this treatise, appended when he ordered it read to him.

When birds are fatigued after their search for food they seek nocturnal rest by sleeping for a time first on one foot and then on the other, just as tired-out four-footed animals do.

There is in this connection another consideration—the feet of birds are almost en-

¹ Acute catarrh, i.e., inflammation of the cranial passages.

² The material from this point to the end of the paragraph not found in the Vatican Codex, is from Bologna MS., fol. 5^r, col. 1.

³ See Vatican Codex, fol. 8^r, col. 1, l. 6, to col. 2, l. 9.

tirely devoid of flesh, being composed mostly of bones, nerves, ligaments, skin, and horny substance (toenails) that in their nature lack warmth. Birds meet this defect by drawing them up alternately under their feathers to heat them.]

When a storm blows up during sleep, birds turn their breasts toward the wind, so that their feathers may remain smooth and not be ruffled, as they would otherwise be were the wind to come from behind, and so disturb them during their slumbers.

CHAPTER IX

HOW LAND BIRDS SEEK THEIR FOOD AND WHY OWLS HUNT THEIR PREY AT NIGHT

Land birds vary greatly as to their habits of moving from one place to another in search of food. Some are good fliers but poor pedestrians, like the larger swallows that Aristotle tells us often appear in the early spring, in the autumn, and occasionally during the summer, especially just before and shortly after a rainy season. They have weak and short legs but long, sickle-shaped wings, like those of falcons, that so interfere with their alighting on the ground (and with their progress there) that they with difficulty raise themselves from it to continue their flight. Consequently they are often noticed on cliffs and suspended in caves so that they may begin their flight from a height. All birds of prey fly well but walk badly, and the same is true of most harmless birds. One may assert that all birds that walk badly fly well, but the rule that birds that fly well walk badly is not without exceptions.¹

Some land birds with an unusual ability

¹ Aristotle claims this to be axiomatic, but Frederick II contradicts the statement. Grebes and divers (almost helpless on land) are also poor fliers.

to walk are flightless—ostriches for example. Others, like the generality of partridges, quail, land rails (called corn crakes), and pheasants, are good walkers but are only medium fliers.

Certain land birds take their food on the wing, others on the ground. Some (for instance, swallows and siskins) devour their prey in the air.² They catch such insects as flies, beetles, bees, wasps, and other flying insects but avoid devouring in the air those provided with stings, which might wound their digestive apparatus. Such insects are generally killed and prepared for deglutition either on the ground or while the bird is roosting on the branch of a tree so that they may be ingested without danger. Others that catch their food on the wing do not devour it in the air, because it is not ready to eat. They rest on the earth or on trees to kill their prey, to prepare and consume it. In this class are birds of prey. Almost all birds which capture other birds in the air usually come to earth or alight on trees to devour their prey.

Some species when seeking their food grasp it with their mandibles, taking it as it is found on the surface of the ground. They do not seek it by first scratching in the earth. Such birds are bustards, swans, and little bustards, who always eat herbs, grain, and worms. Others turn over the soil with their feet when they find no food on the surface. Among these are partridge, hens, pheasants, peacocks, and quail. Still others scratch with their feet and dig holes in the earth with their mandibles and eat any food they can find either above or below the surface. Such are especially jackdaws, crows, ravens (which are like small crows, only all black) as well as magpies and starlings. These birds and

² Why siskins (*sirone*) are associated (as examples of this habit) with swallows is strange, since the former rarely if ever act in this fashion. Flycatchers, the common thrush, and the nightingale would have been more appropriate.

others like them have, besides, many other methods of acquiring food.³

The common food supply of land birds is of great variety; some eat almost anything except meat, others subsist on flesh and other fare, some on flesh alone. Partridges, red-legged partridges, pheasants, peacocks, and francolins live chiefly on grain and the fruits of trees and shrubs, but they will eat also grasshoppers. This is likewise true of quail and similar fairly swift fliers, such as pigeons, turtledoves, and ringdoves (that are larger than the two first-named), as well as bustards and the lesser bustards, that in color, shape, and other characteristics resemble the larger species but are much smaller in size.

Some birds do not feed on grain, herbs, or fruit but swallow readily ants, spiders, and worms, like the woodpeckers.

Others, generally little species, prefer fruits, seeds, and small, living creatures that they find on trees, among weeds and on the ground; and there are birds that live indifferently upon all forms of food.

Ravens, crows, and magpies feed impartially on flesh and other kinds of provender; their meat pabulum may be the carcasses of animals killed and left by men, birds, and beasts. They rarely attack a living bird or any mammal unless it is very weak or crippled. When this kind of animal food is lacking they will eat grain, fruit, locusts, worms, beetles, and other food found either above or under ground.

Carnivorous birds may be divided into three classes. Vultures and lammergeiers (lamb vultures)⁴ never kill any animal for food, but live on carrion. Others prefer dead animals but sometimes kill for food, as do kites and the common eagle. Others, like the true falcons and hawks, devour only what

³ Here the Vatican text adds: *quae tediousius esset narrare ad presens.*

⁴ Probably the *Geier* when driven by hunger may attack for food small, live animals; but the stories about their carrying off human infants are mythical.

they themselves kill; they never eat a dead body.

After detailing the great variety of food consumed by land birds it remains to discuss their aerial habits—when and whither they ordinarily fly. The hours of their going and coming are not so definite as with water-fowl, which are almost without variation. Partridges, red-legged partridges, pheasants, and francolins, which have restricted powers of flight, leave their resting places at definite hours. Swift fliers, like the pigeons, prefer sunrise for departure and remain abroad until nine o'clock, when they return to their bushy or grassy retreats. But the weaker fliers, by reason of their infirmity and because birds of prey seek them on account of their delicate flesh, fear to remain the whole day feeding away from their usual resorts; so they seek food in the early morning near their resorts, and return from the fields about midday. After three o'clock, however, they again go forth for food and remain in the fields until sunset, after which they return to their resorts for the night and all is quiet.

In general it may be stated that birds hatched in trees and accustomed to roost there will choose at night an arboreal resort; just as those hatched among rocks, or bushes, or on the ground, return to them at night.⁵

Many land birds have no set time for ex-

cursions but fly off at irregular hours, early as a rule or in time to reach their feeding place, where they remain all day, flying about and feeding. They return about sundown, to spend the night safely and to rest. Such birds are magpies, various species of crows, jackdaws, starlings, vultures, and lammergeiers. Small land species, such as larks, wood larks, sparrows, and their kin also seek their food (if the weather is favorable) any time during the entire day. Unlike other land birds they have no fixed haunts, although they usually return to the place in which they were born or to one resembling it.

There are also birds who look for food all day long, particularly from nine until three o'clock, when they hawk flying insects, such as bees, wasps, and beetles. Good examples of these are the siskins.

CHAPTER X

OF THE FLIGHT OF LAND BIRDS TO THEIR FEEDING GROUNDS, THEIR RETURN, AND THEIR GENERAL CONDITION

Land birds fly to their feeding grounds in various fashions, many in flocks of a single species definitely arranged, while others are solitary. Examples of the former are found in turtledoves, pigeons, (particularly) starlings, and many others of the same type, who, even in their mating season and while brooding, do not avoid the society of others but are seen in flight with them. Birds of prey fly singly to their feeding places, but at the mating and breeding season the male pairs off with the female, just as do other birds. Some raptorial, for example a certain species of falcon, hunt their quarry in flight—locusts, grasshoppers, or beetles, for instance—which they grasp not with their beaks but with their talons and swallow them while still on the

⁵ An exception is the pheasant, which incubates on the ground but roosts at night, sometimes during daytime, in a tree.

At this point in the Bologna Codex (fol. 6^v, col. 1, ll. 1–20) there begins a passage referring to the habits of birds of prey which is later repeated as a part of a longer paragraph that deals with that topic. In the Vatican Codex the text here is partially illegible, but it clearly contains a portion of the repeated matter, as well as a passage almost entirely undecipherable that is not contained in the first Bologna passage but does appear in the longer passage mentioned, which is entirely missing from the Vatican manuscript. To solve the problem of arrangement, we have omitted at this point all the repetitious matter and have given the full text of the second passage as it stands in the Bologna Codex (fol. 7^v, col. 2, l. 23, to fol. 9, col. 1, l. 43). See also chapter xv-A, p. 28.

wing because they do not need to kill them¹ or otherwise prepare them for food. A number of rapacious species, especially young falcons, also seek this kind of food.

Certain land birds go abroad in flocks, like partridges, but not during the pairing season. Others, such as pheasants and quail, go about singly, except the young, that follow the mother. The small land birds fly in and about trees and shrubs, and close to the earth, for they find their food everywhere.

Vultures and their kindred keep a lookout from lofty crags or trees, on the watch for men who kill animals, or birds that fly to carrion, or wolves and similar wild beasts which hunt and kill quadrupeds. When they spy one or the other of these, they quickly spread their wings and gather around the dead body. When one of them sees any food, he at once pounces down on it; his companions, seeing him, follow the lead.

A vulture is not attracted to his carrion food by a sense of smell, although some writers maintain that he is, but relies on his eyesight.² We have ourselves many times experimented and observed that an assemblage of seeled vultures, whose noses were not stopped up, did not scent the meat cast before them. We have also made the observation that vultures, even when hungry, will not catch live birds and refuse to seize chickens when thrown to them alive and before their eyes but which they eat after they have been killed. They push their head and neck through any opening in the slaughtered carcass and feed on its interior; hence the heads and necks of most vultures are bare of feathers.

¹ The Emperor had in mind and evidently referred to the kestrel (*Falco tinnunculus*), and its near relative, the South European *Falco cenchris*, which are harmless birds and live to a large extent on insects.

² The Emperor came to this true conclusion by his own careful observations and experiments, which have been repeated often since his reign, and in modern times with similar conclusions.

CHAPTER XI

OF NEUTRAL BIRDS: HOW AND WHEN THEY OBTAIN THEIR FOOD

Neutral birds employ a variety of methods to secure their nutriment. Some of them run here and there, frequently changing their locality, digging food out of the earth or grasping it with their mandibles, like curlew, plovers, and lapwings. Others proceed more leisurely, not running but flying from place to place, not neglecting to dig in the ground with their bills, as do the cranes. Still others search with their beaks for reptiles that live under ground and for other animals upon which they can subsist; but they reject grains, herbs, and the fruit of trees and of herbs. Among the last-named are the black and white storks—neutral birds that are not swimmers, but are good fliers and often leave the vicinity of water to wander about on land in search of food.

CHAPTER XII

OF VARIOUS FOODS CONSUMED BY NEUTRAL BIRDS

Neutral birds consume the following varieties of food: Some avoid entirely food of aquatic origin, preferring such land products as grains, grass roots, and seeds of fruit trees, grass, and shrubs. Geese, for example, dig avidly for the roots of herbs, particularly of the plant called *Yari*.¹ Others subsist on worms they drag out of the earth and on those small creatures they find on the surface of the ground such as locusts, grasshoppers, beetles, and other insects (winged and wingless), which they seek about the plant life of

¹ Schneider translates this word *Serpentaria minor*, Aaron's Beard, a name given in English dictionaries to quite a different plant. We suggest, however, that Frederick II was referring to what in Italian is called *Iaro*, arum, or wakerobin—the American trillium.



PLATE 41.—Portal of the Cathedral at Bitonto (1200).



PLATE 42.—Courtyard of Gioja del Colle, "Jewel of the Hill," a favorite hunting retreat of the Emperor

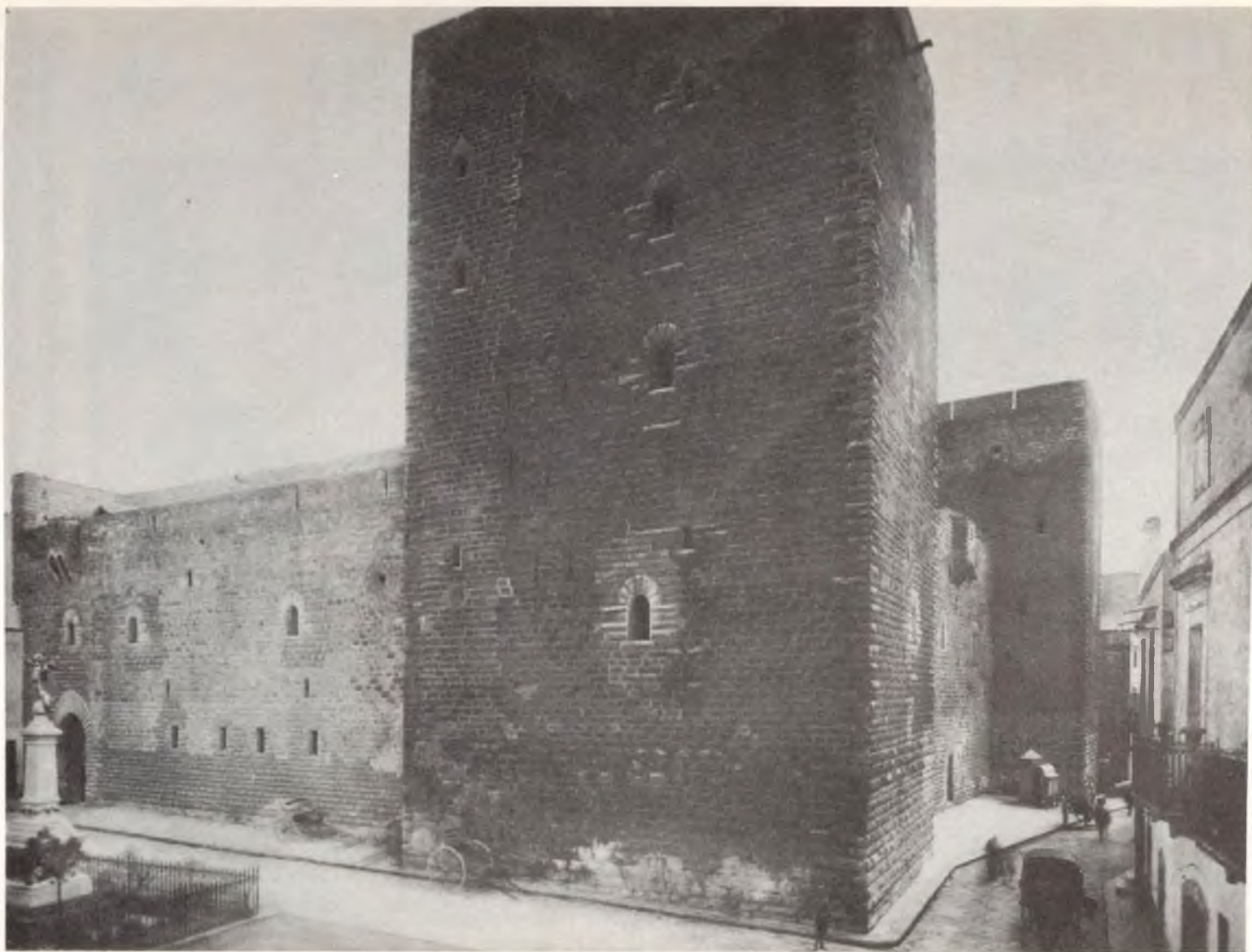

PLATE 43.—Palace at Gioja del Colle, one of the castles built largely to provide for the Emperor's falcons and falconers



PLATE 44.—Fish hawk, or osprey. A fine representation of a bird of prey in action

fields, bogs, and plowed land. Examples of these birds are curlew, lapwings, and plover, as well as other species that are armed with long beaks (such as curlews have) and gain their food by boring by means of it into soft soil. Snipe, however, live mostly on common beetles, grasshoppers, and scarabs (dung beetles). Others, like the storks, prefer fish, worms, such creeping animals as snakes, and those animals that walk, like lizards, frogs, mice, and members of the toad family, some of which are poisonous to men and many lower animals.

CHAPTER XIII

OF THE EXCURSIONS OF CERTAIN NEUTRAL BIRDS

Some of these birds leave their habitations at irregular periods, early or late, confining themselves all day to their favorite feeding locality—like curlew and lapwings. Some of them make such a change twice a day, i.e., those that, like cranes and waterfowl, have their resting places and shelter on the water and return to these resorts twice a day. Of the inland birds, storks make excursions twice a day to their feeding grounds, while some, for example snipe, do not venture this flight during daylight, for fear of birds of prey, but go abroad at night.

CHAPTER XIV

OF THE VISITS OF NEUTRAL BIRDS TO THEIR FEEDING GROUNDS AND THEIR ORDER OF FLIGHT

The manner in which certain neutral birds fly to their feeding localities varies. Some go in flocks, except when, as in the case of cranes,

plover, curlew, and lapwings, they have young ones; others, storks for example, on both the outward and the return journey, fly singly and alone; this is true also of snipe. Other birds fly off, without preserving any order, either separately or mixed with other species.

CHAPTER XV

OF THE RETURN OF NEUTRAL BIRDS TO THEIR USUAL DWELLING PLACES AND THEIR CONDUCT THERE

The halting places chosen by neutrals in their excursions vary greatly and depend upon the season of the year. As a rule they seek those localities where they believe food is to be found in greatest abundance and best suited to the species. In particular, as will be noted, the presence or absence of raptorial birds is always to be considered.

Few birds fail to return to some sanctuary where they can pass the night safe from beasts of prey; only lapwings sleep in the fields at night. Storks prefer towers, treetops, and other eminences; cranes seek aquatic sleeping places like true water birds. As a rule, birds patronize the same sort of resting place their mothers chose before them, as being the most secure in which to raise them as fledglings; and they, in their turn, seek those refuges that most closely resemble the maternal rendezvous. Some pass the night in fields, sleeping on the earth. These include certain kinds of small pigeons that have cocus-colored or yellow beaks. There are still others that, although they nest on the ground, roost in trees at night, like pheasants and hens. Neutrals sleep on one foot, like water and land birds (both the rapacious and the harmless varieties), as has been explained.

CHAPTER XV-A¹

OF RAPACIOUS BIRDS, THEIR EXCURSIONS AND METHODS OF SECURING FOOD, AND OF ITS KIND; ALSO OF THEIR RETURN TO THE EYRIE

Although we have already spoken of land birds, among whom are included birds of prey (we do not, indeed, consider any aquatic or neutral birds to be rapacious in the sense in which we have previously defined the raptores), we shall introduce here a chapter in which we explain the movements and performances of some raptorial species in securing their food, what they eat, their excursions after game and their return to their usual resorts. They all make certain special changes of locality and other operations that differ greatly from those of other land birds. In this way it will be better known where birds of prey are best obtained and what varieties of harmless species they are most easily taught to hunt.

The raptores are in general provided with stronger wings than nonrapacious birds. Many of them, by means of their rapid flight, are able to pursue for long periods their fleeing prey, which, when overtaken, they seize in their claws—wounding and tearing it—and finally beheading it by means of their mandibles. This is characteristic of both large and small falcons.

Some raptores, such as eagles and the large and small hawks, when they have succeeded, by their remarkable speed and great skill in flight (including, if need be, a long pursuit of the quarry), in seizing and retaining their

victim in their claws, force it violently down to earth.

Certain falcons, when they do not find small birds to catch on the wing, fly hither and thither hawking such food as locusts, grasshoppers, and beetles, all of which are caught not in the beak but with their talons and are consumed in flight. As it is not necessary for rapacious birds to kill this kind of food or to prepare it for consumption, it is a favorite pabulum while they are young and small. Immature birds hawk their food in the same manner as mature falcons.

Certain falcons hover on extended wings high in the air. They do not fly about hither and thither, but watch until they see some small animal on the surface of the earth, such as a mouse, lizard, or similar creature. Then they descend swiftly, seize and tear it with their claws. This is the habit especially of those birds called kestrels (*clisterelli*). Other raptores, such as the screech owl and other nocturnal birds of prey (*noctuarum*), secrete themselves by day and hunt at night.

There are still other methods and plans adopted by birds of prey in seizing their quarry of which we shall speak later and at greater length. It may here be said, however, that they all are sharp-sighted and fly high in order to see their possible victims at an immense distance.

This last group of raptores, consequently, look about from a great altitude and if they see any suitable prey, either on the earth or in the sky, rush at it; and if they perceive no other hawk pursuing quarry, they close in on their own victim. However, since they consider prey discovered and tired out by another hunter easier to catch, it is not unusual, when some other hawk has already seized an animal and is holding or carrying it off, for them to pounce on it and fly away with the quarry already captured. It is for this reason that a single hawk generally hunts alone and not in the territory of other rapacious birds.

¹ This chapter appears only in the Bologna and other six-book manuscripts. It contains a passage (later indicated, p. 30) that forms part of chapter ix (Book I) of the Vatican and other two-book editions but which is missing in that chapter of the six-book codices (cf. also page 21). It contains, also, a passage that is a repetition of part of chapter ix of the Bologna text (which we omitted in our translation) and which is later indicated.

As a result of this plan no bird can steal another's captured prey or rush in ahead and seize an already spotted victim.

Most raptores, including those that loot other birds' food, carry their prey to trees or to the earth, there to kill and prepare it for eating. Rapacious birds do not swallow their avian food quickly and quietly, no matter how hungry they may be or with what eagerness they have joined in the chase. They must first deplume and tear it to pieces, eating it little by little; and in so doing they must of necessity make violent movements. In consequence, other birds of prey, seeing a hunting bird carrying her prey, or catching sight of the feathers flying as she deplumes it and perceiving the nature of her task, may rush in on her and carry off the quarry. Therefore, through fear of losing her prey and of being herself interfered with or seized by a rapacious bird of some other species, she flies and hunts alone.

Although a bird of prey may attack a fellow hawk, it does so only when other quarry is not available. All birds of prey are afraid of attacking another raptorial and prefer to assail a harmless variety, since the former is armed with strong talons and beak. If a rapacious bird does attack another bird of prey, it is done only under the urgent impulse of hunger; and then a large bird usually attacks a smaller one, generally an individual of another species.

The avian nutriment of hawks and falcons is of great variety; although, as has already been stated, all rapacious birds prey and live upon any sort of bird or beast that they are confident of catching and holding. And in that connection it may be remarked that the larger raptores hunt somewhat larger animals than do the smaller birds of prey. The following differences in diet will be noted. Those larger rapacious birds that hunt and seize young deer and goats, and strangle hares, rabbits, and similar animals also seek as

food land birds, waterfowl, and neutrals, but prefer birds of medium size. They seldom take large birds and rarely or never the smaller avian species. In this class of raptores we find eagles, gersfalcons, and the larger hawks. Waterfowl are more to the taste of those falcons called peregrines that frequently feed on ducks and similar aquatic birds. Some hawks and noble falcons prefer such land birds as pheasants, partridges, guinea fowl, and most varieties of pigeons, ringdoves, francolins, and turtledoves. The lanners choose crows, magpies, and jackdaws. All these falcons and hawks, however, will be more fully and clearly described in a second treatise² and others to follow in which our own interest in the whole subject will disclose itself. Other smaller birds such as lapwings, plover, crows, starlings, larks, sparrows, etc., are hunted by sparrow hawks and those we call *simboliones*.³ Some raptorial, among them both large and small owls, prey upon the young of other birds, mice, and those animals that go about at night. Certain others prefer field mice and lizards, frogs, beetles, grasshoppers, and locusts; among them are the hobbies,⁴ merlins,⁵ and kestrels.⁶

Some birds of prey⁷ leave their refuge to go hunting early in the morning and return later to their nocturnal quarters. If the food of which they have partaken in the morning is not sufficient to sustain them until the following day, they operate again after three

² This may be the promised work on hawks that was probably never written, or it belongs to the category of "lost manuscripts"; in our opinion, however, Frederick II is referring here to Book II of the present work when he uses the expression, *in secundo tractu*.

³ The translators can find no English equivalent.

⁴ *albari*; this suggests the Italian *albanella*, hobby.

⁵ *besardi*; merlin is offered as a possible translation.

⁶ *clisterelle*.

⁷ This paragraph and the next form part of the text of chapter ix in the Bologna MS. (fol. 6^r, col. 1), but they do not appear in any part of the Vatican Codex. We omitted them at that point in the translation, to avoid repetition.

o'clock. This food shortage may occur when available quarry is not enough for present needs, or because, having caught sufficient prey for a meal, the bird was forced to leave it; and when this happens, falcons and hawks go out a second time in search of food.

It has already been seen that sometimes falcons hunt their prey at night (chiefly by the light of the full moon) because they are unable to catch anything in the daytime; from which fact it may be deduced that certain rapacious birds at times perform acts, when urged by necessity, that are otherwise unnatural to them.

On the other hand⁸ there are birds of prey, such as screech owls and other nocturnal species, that regularly seek their food twice in the night. When the nights are very dark they go out after sunset in the evening light, and again at dawn. In bright moonlight they hunt at any hour. It may be said without exception that those species that hunt at night do it not so much because they can see at night and not in the daytime (as Aristotle asserts)—for they have good vision both by day and by night—but because they feed on the young of other birds. They are hateful to such birds and, therefore, do not dare to hunt during the day. [Like certain quadrupeds that possess poor physical armament, they hide by day and seek their food at night and in this way avoid the harm that might befall them if plainly seen. They are not only visible in bright daylight to those who would harm them, but their presence is revealed by odors left in their path,]⁹ since they void their ex-

⁸ This paragraph is contained in chapter ix (Book I) of the Vatican Codex and the Velsler edition, but is defective in both. It forms a part also (with the exception of the portion noted below) of chapter ix of the Bologna text.

⁹ The last two sentences (up to this point) are contained in chapter ix of the Vatican Codex and its derivatives but not in the corresponding chapter of the Bologna MS., although, as stated above, the remainder of the paragraph forms part of both the two-book and the six-book editions of that chapter.

crements. Birds that have no effective means of defending themselves follow a similar course. They go out at night so that they may not be seen by rapacious birds and other animals that would harm them.

Certain species of harmless birds rush in flocks and mob their raptorial enemy. Making use of this characteristic, bird catchers attract to birds of prey (placed in their treacherous nets) other birds they wish to trap. At night, however, when these unfriendly birds are asleep, nocturnal hunters invade their quarters and, emboldened by repeated successes, easily seize their prey.¹⁰

The localities in which the raptors hunt are various. Those that live on land birds choose chiefly open country; others, that prefer water birds as food, seek the vicinity of pools and streams, while those that feed on one or both species are to be seen in either locality. In other words, birds of prey generally seek their food in places where dwell or feed the birds or small animals on which they live.

The places to which they return (after the hunt) to rest and spend the night are also diverse. As a rule, they select a locality similar to the one where they were born, i.e., cliffs, trees, and other prominent situations, whence they may ward off any threatening danger and spy out from afar their necessary quarry.

Raptorial species have a special preference for their own eyries, to which they return for rest as long as they remain in the neighborhood and which they desert only when forced by overwhelming circumstances¹¹ to abandon the region.

From all this one may judge what kind of food is preferred by aquatic, neutral, and

¹⁰ This passage, a partial repetition of chapter ix, ends here.

¹¹ This paragraph forms part of chapter ix in the Bologna text, but in a different position. In that chapter it follows the paragraph ending "that are otherwise unnatural to them" (see col. I, above).

land birds, both rapacious and harmless. Lacking the chosen fare, falcons eat indifferently the pabulum they have tried and found suitable, i.e., whatever they can digest and that is nutritious.

Those birds that eat grain and food other than flesh do not exchange these foods for meat, because they are not provided with organs suitable or adapted to the consumption of meat as well as other food; and, vice versa, the digestive apparatus of constant meat eaters is not constructed to prepare and digest other foods as well as meat. Those that have organs adapted to a mixed diet (with or without meat) change indifferently from one to the other, since they are born with organs that enable them to digest either, as is explained above.

From a study of this diversity of food which various avian species are accustomed to eat, the diligent investigator may learn on what fare individual birds are best nourished and the best kind of food to give them. This rule not only applies to rapacious birds kept by man in captivity but may well indicate what birds form the best nourishment for human beings themselves—which species are inferior as food, which are suitable, and which are unsuitable for man's consumption. It may be affirmed that, as human fare, those animals that eat both flesh and other food indifferently supply us with inferior meat and poor nourishment.

The same is true of all animals that eat only meat. Those birds that prefer fish are most undesirable for human regimen and, as before stated, are chosen only by those rapacious birds accustomed to them. Birds that eat grain, grass, and fruit furnish good meat and nourishment, while those that live on grain alone make the ideal diet and provide by far the most tasty and most nourishing food. For that reason most birds of prey consume them with great satisfaction and hunt them with pleasure.¹²

CHAPTER XVI

OF THE MIGRATION OF BIRDS TO ESCAPE THE COLD¹

Now that we have described what is necessary concerning the diet of rapacious and nonrapacious birds—aquatic, neutral, and terrestrial—we must consider their movements during the changes of the seasons. Birds make, as a rule, two such excursions a year, that is, from a cold climate to a warm one, and from a warm climate to a cold. The first journey to be considered—that from the cold to the warm—occurs after they are hatched and have gained their full strength and plumage. We call this their migration or passage, because they journey from cold regions, the land of their birth, to distant warm countries; the second change of residence is after the winter season and is made from warm to cold regions. But as not all birds undertake this second migration, it is important to consider the species that do migrate; why they follow this or that course, how they prepare for their journey, the time of the year they set out, the sort of weather that influences them, which of them depart the soonest and why, what order they maintain in their flight, from what localities they depart, at what points they descend to earth and rest during their migrations, and, finally, their ultimate destination, and for what purpose and how long they remain there.

¹² This long passage on birds of prey and their methods of hunting and of preparing and consuming their food is found as a whole only in the Bologna and other six-book manuscripts of the *De Arte*. As has been indicated, portions of it are found in chapter ix (Book I) of the Vatican Codex, and its derivatives, and also as repetitions in the same chapter of the Bologna manuscript. See footnote 5, p. 21.

¹ Modern ornithologists recognize at least three forms of avian migration: (1) true migration; (2) incomplete or limited migration with no definite goal or time limit; (3) wandering about in a restricted area, in no particular direction, and without regard to duration of the search for food or for a better habitation.

CHAPTER XVII

OF WHICH BIRDS MIGRATE AND AT
WHAT SEASON

As migrants, first in order come the waterfowl, including those that live on fish alone or on fish and other aquatic food, as well as those that prefer terrestrial products or that feed on both; the last-named are, however, not good fliers. Next in order come the neutrals, especially those that subsist on worms dug out of the earth. Land birds, both the raptorial and harmless species, large or small, are also birds of passage.

Not all water, shore, or land birds migrate; those who are unable to take long flights, inclusive of weak or disabled individuals, cannot make this journey, particularly to distant lands. They make another change in place of it, moving to neighboring localities; in winter, perhaps, they fly from hills to valleys near by and in summer come back again from the valleys to the mountains. This is the habit of such land birds as partridges, red-legged partridges, pheasants, peacocks, bustards, and, generally speaking, most of those birds that do not pair off during the breeding season. In winter some aquatic birds seek (neighboring) warm waters, either a large river, the sea near by, deep thermal springs, or lakes the waters of which have a summer temperature. This is the habit of such limited fliers as mergansers and rails. Superior fliers, who have become weak or lame, also make a change of this sort instead of attempting to migrate to far-off regions. These handicapped birds, though true migrants, are dubbed, in the neighborhood where they remain behind, "natives,"¹ since they become, as it were, permanent residents.

Of course, birds born and living in India and in regions below the equator or near it

¹ The Bologna text (fol. 9^v, col. 1) says "*patriane*"; the Vatican Codex (fol. 13, col. 2) has "*paysane*."

(the Tropics) build their nests there and rear their offspring until they are mature. They need not migrate to procure food elsewhere or to avoid excessive cold, since in those regions the sun reaches the zenith twice in the year and they have really two annual springs, two summers, two winters, and two autumns. Consequently all avian foods—fruits, herbs, seeds, locusts, and beetles—are found in abundance. Moreover, no cold of winter does injury to bird life, since the sun is always overhead except for 23° or less. Since tropical birds feed their young in spring and summer, like other avian species, if they wish to migrate and avoid excessive heat above or below the equator they can do this in a direction reverse to that of the solar movements. If they wish to avoid cold, they can easily find a hot climate. However, they are much more likely to be forced to escape excessive heat, particularly at the time they build their nests and rear their young; but even at that time they do not migrate to a great distance. Like other nonmigratory birds they easily make a short change from valleys and plains to mountains or woods near by, from neighboring warm to cool waters, and thus avoid extreme heat, and follow the contrary rule to avoid cold.

CHAPTER XVIII

OF THE REASONS WHY BIRDS
MIGRATE

The reasons why birds desert their usual resorts are numerous; but, as we have said, it is chiefly to avoid excessively cold or very hot weather. For birds, like other living creatures, depend for their existence and survival upon a certain balance of fundamental conditions, and for this reason (since due proportion is conserved by moderate and destroyed by excessive heat or cold) birds require for their well-being a moderation of the atmos-

phere and other environmental conditions; so they take refuge from extremes of either heat or cold. Although they can pass spring and summer comfortably in cold climates, northern resorts become disagreeable in autumn and winter. Birds, therefore, seek warmer haunts even though these are to be found only in remote countries.

Other reasons for migration are less important. One such explanation is their search for food; when water freezes and herbage dries up, and the surface of the soil solidifies so that grass seeds, fruits, and other foods that fall to the ground cling to and become part of the hardened earth, and when even the worms beneath the soil cannot be reached, it is with the greatest difficulty that birds obtain their necessary fare—flesh, fish, plants, or insects—with the result that they fly off to warmer localities where neither earth nor water freezes and there is no scarcity of food.

For rapacious birds it is no less needful to seek change of climate, although they can withstand temperature variations better than most other birds; but as they feed on avian species it is necessary to follow the latter on their excursions to milder climates.

Also, smaller birds—goldfinches, black-birds, starlings, redwings, and thrushes—migrate for the reasons mentioned above. Cranes, herons, geese, and ducks also change their temporary habitat because of intemperate weather conditions. Storks, curlews, plovers, lapwings, and all those birds with long bills who cannot bore into the frozen earth for food, as well as snipe, which live on beetles and other insects, join the migrating flocks.

Among other reasons for a change of climate are the heavy rains, storms, and snowfalls of cold countries, which make bird flight and life generally very difficult. Still another explanation of avian migration in the case of waterfowl and some neutral species is that the freezing over of their aquatic resorts ren-

ders these localities useless as a refuge from predatory beasts and birds of prey. So they seek a climate where watery sanctuaries do not freeze.

CHAPTER XIX

HOW BIRDS PREPARE FOR MIGRATION

Birds do not prepare for migration as soon as they leave their nests, for they have neither the strength nor feathers firm enough to transport them for great distances. Moreover, the cold weather does not, generally, set in to compel them to migrate, and there is still plenty of food available. The young birds fly about their birthplace from early spring to late summer, sometimes with their own, sometimes with other species, alone or in numbers, without apparent plan or purpose. As summer wanes and winter approaches, both young and adults leave their breeding grounds and gather with their own kind, young and old (indiscriminately), waiting, feeding, and preparing, for a day favorable to their long journey.

This takes place in the case of all migratory water, neutral, and land birds with the exception of certain land birds.¹ Raptores, however, never prepare for migration by mingling with other birds of prey, whether of the same or of different species, because it is their habit to rob each other of any quarry that is caught. They therefore travel alone in fear that another rapacious bird may carry off their prey.

As noted, most neutral, land, and water birds assemble, species with species. It must be remembered that, although different species that closely resemble one another may

¹ Here the Vatican text (fol. 14^v, col. 1) adds "*praeter in rapacibus sicut dicitur in suo capitulo*" and then omits the two sentences that follow in this translation.

feed in the same localities and may mix freely, rarely or never will they form flocks with each other, no matter how closely related they are. They will gradually join their fellows, as may be seen in a promiscuous gathering of geese, from which red geese, gray geese, barnacle geese, and small geese gradually withdraw and finally make up distinct, specific groups.

As cold weather looms in one locality after another, birds migrate little by little from one vicinity to another. In moderately cold countries preparations for migration are more prolonged than in climates where severe winters are the rule.

CHAPTER XX

OF THE SEASONS AND WEATHER THAT FAVOR MIGRATION

With a prophetic instinct for the proper time to migrate, birds as a rule anticipate the storms that usually prevail on their way to and from a warmer climate. They are conscious of the fact that autumn follows summer (when they are strongest and their plumage is at its best) and that after these seasons comes the winter—the time they dread most. They are instinctively aware of the proper date of departure for avoiding the winds to which they may be exposed in their wanderings and for eluding the local rains and hailstorms. They usually are able to choose a period of mild and favoring winds. North winds, either lateral or from the rear, are favorable, and they wait for them with the same sagacity that sailors exhibit when at sea. With such helpful breezes progress and steering in the air are made easy. With these to help them on their way, they reach, with comparative comfort, the distant lands of heart's desire. When they fly before the wind

they can rest on an even keel, still maintaining progress, especially when propelled in a proper direction. When becalmed they do not fly so satisfactorily, for they must exert themselves all the more. With head winds there is a threefold difficulty in attempting to float, to fly forward, and to overcome direct aerial obstacles.

Among flight obstructions there are also to be considered not only contrary winds but local rains, hailstorms, and other forms of bad weather that may affect both air and sea, so that some birds fall into the ocean and others, when possible, fly on board a ship (where they are easily caught), preferring that fate to certain death or to continued exposure to the rigors and dangers of oceanic storms.

We notice also that when a favoring wind springs up, whether by day or night, migrating birds generally hasten to take advantage of it and even neglect food and sleep for this important purpose. We have observed that migrating birds of prey, that have begun to devour food we have thrown to them, will abandon it to fly off if a favorable wind begins to blow. They would rather endure hunger and travel day and night than forego such an advantageous opportunity.

The calls of migrating cranes, herons, geese, and ducks may be recognized flying overhead even during the night, and not, as Aristotle claims, as a part of their efforts in flight; they are the call notes of one or more birds talking to their fellows. For example, they understand wind and weather so thoroughly that they know when meteorologic conditions are favorable and are likely to remain so long enough to enable them to reach their intended haven. Weak fliers postpone their journey until they are sure of a prolonged period of good weather sufficient for their migrating venture, but hardy aviators take advantage of the first propitious period to begin their flight.



tout en l'an: qu'au l'autre
 pour ce deuantissent il se re
 cendent loz trespas: car dau
 cunes especes li aucun puer
 met: souuent la chaleur &
 le froit: ou autre mal tens:
 selonc la quantitee et la cali
 teti de loz cors: d'ltre plus del
 oisiaul d'une meisme espee
 ainsi com de grues et d'autres
 oisiaul: al qui ont a trespasser
 des loz loz loz lieux: cest
 a sauoir des parties deuers
 Pour ce que uers la en comen
 ce plus tost puer li froit: et
 pour ce que li oisel qui sont
 la ont plus longue uoie a
 faire plus tost il separellent
 a trespasser: Al qui sont de
 celle meisme espee qui demen
 rent et lient moins loz loz
 et toute uoie ont a trespasser
 pour ce que li froit loz uient
 plus tard: et quel ont plus
 petite uoie a faire: il comen
 cent a trespasser plus tard
 loz trespas: Car il acoment
 toz uoies que la sperec: don

tens a trespasser: et li oisel
 de cense o il sont plus pres
 de lequinocial: de tant il en
 commencent a trespasser
 plus tard: Ceste chose gar
 dent en trespas sans que li
 oisel aquatique: car il ne
 uolent pas confuser: mais
 ne desordene: ainsi a
 uolent al qui sont apele
 oisel cecel: car li cecel
 ne se peument garde ne
 metent face en loz uoies: et
 quel sont premiers ou der
 riers en loz multitudes: ainsi
 li aquatique gardent ceste
 ordre au plus que il puer
 cest a sauoir que li uns va
 deuant et l'autre de der
 re: et ainsi par succession
 les lient: et en double rou
 te l'une a l'autre et l'autre a
 l'autre: et aucune fois sont
 plus loz en l'une des routes
 que en l'autre: ainsi cede
 nces seprachent de la et de la
 a celi qui va deuant en me
 niere de 14 lignes assamblees

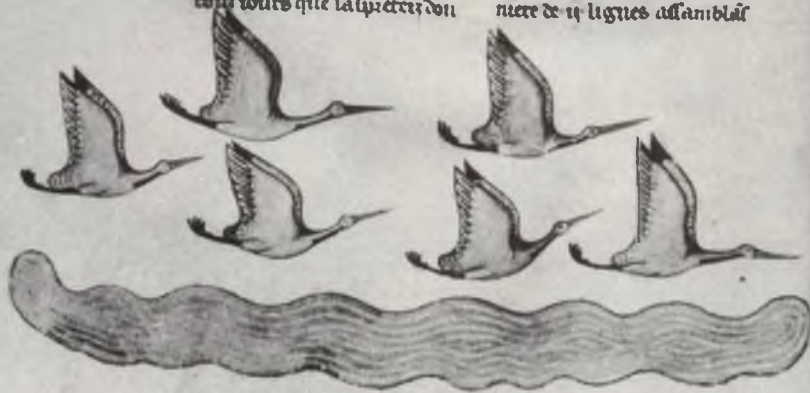

PLATE 47.—Folio 26^r of the French translation of the *De Arte Venandi* (Bibliothèque Nationale MS. Fr. 12400). When compared with Plate No. 46, this illustration is revealed as little more than a slavish copy of the original.



PLATE 48.—Page describing and illustrating birds' crests; also containing the reference to the parrot (?) sent to Frederick by the Sultan of Babylon (Bibliothèque Nationale MS. Fr. 12400, folio 30^v)

CHAPTER XXI

OF EARLY AND LATE DEPARTURE IN
BIRD MIGRATION, AND OF THEIR
FLIGHT FORMATIONS

The slower migrants begin their departure early. For example, the smaller birds, as well as storks and herons, remain until the end of summer and leave the last of August so that they may not be embarrassed by changeable weather or early (autumn) storms. The more robust species and better fliers remain until the beginning of harvest (about the middle of September). Among the latter are the larger and smaller cranes. At that date strong fliers can readily defy the early winds and rains. There are, moreover, still better and swifter fliers who postpone their departure to the end of the autumnal season, say, until November. These include certain ducks and geese who do not fear high winds and heavy rains because of their skill in flight and because their plumage protection against cold is adequate. This rule applies also to the smaller geese who may remain behind in the sixth and seventh climatic zones¹ the whole winter through, inasmuch as they can find there the herbage on which they feed. The larger geese also possess unusual meteorological instincts and avian alertness. In years when there are short summers, i.e., when the winter threatens to set in early, they migrate much sooner than usual.

¹ Abu Abdallah Mohammed Idrisi (ca. 1099–1154), the Arabic geographer, attached for twenty-five years to the court of Roger II (1101–1154) at Palermo, was the author of *Al Rajori*, or *The Going Out of a Curious Man to Explore the Regions of the Globe, Its Provinces, Islands, Cities and Their Dimensions and Situations*. In this work Idrisi not only describes journeys to such places as Scandinavia, the African coast, Egypt, Syria, etc., but he recognizes the rotundity of the earth. He divides the known world into seven climates between the equinoctial line and the point where the earth becomes uninhabitable because of extreme cold. Longitudinally he makes eleven divisions between the most westerly point of the African continent and the eastern coast of Asia. Two manuscripts of his work are found in the Bodleian Library and two in the Bibliothèque Nationale.

Certain birds, cranes for example, who pass the summer in the far north (where winter comes on early) on account of the longer journey before them, migrate sooner than others of their species who, having nested farther south, prolong their northern visit, since their winter comes later and they have a shorter journey to make. When autumnal winds are favorable, these birds resume their southern flight and, traveling without intermission, quickly accomplish the voyage. Inclement weather, however, may delay the flight of species that have hatched their young in more southern localities until the storm has passed. Those nearest the equator begin their migration last.

The order of avian departure may be summed up as follows: not all shore birds depart pell-mell, like the disorderly land birds; the latter do not seem to care what birds lead the van or which form the rear-guard of the migrating flocks. Water birds, on the contrary, preserve the following order: one forms the apex of advance, and all the others in the flock follow successively in a double row, one to the left and one to the right. Sometimes there are more in one series than in the other, but the two rows, meeting at an angle, form a pyramidal figure. Occasionally there is a single line.

This order they maintain not only when migrating to distant points and returning but, as has been explained, in going to and from their local feeding grounds.

One member of the flock continually acts as leader and, especially in the case of cranes, does this not because he alone knows the goal they seek but that he may be ever on the lookout for danger, of which he warns his companions; he also notifies them of any change to be made in the direction of flight. The whole flock is thus entirely under control of their leader or guide. When the latter becomes fatigued from the performance of this important work, his place in front is taken

and his duties are assumed by another experienced commander, and the former leader retires to a rear rank. It is not true, as Aristotle asserts, that the same leader heads the migrant column during the whole of their journey.

CHAPTER XXII

OF LOCALITIES WHENCE MIGRATIONS START, AND OF HALTING PLACES ON THE JOURNEY

The departure of migrating birds is generally from localities as far north as local conditions permit avian life. Even from regions well within the seventh zone there will be found plenty of waterfowl and other birds wherever the weather is good, as will be explained later. Indeed from almost every other zone birds migrate, including the sixth, fifth, fourth, and third.

To have a general understanding of this important subject it must be remembered that no migrants remain throughout the winter in the places where they were born but leave them to take up their residence in warmer climates. If they did not migrate it would be wrong to call them birds of passage. The only exceptions, of course, are those that remain behind because of weakness or illness.

Birds living in the first and second zones¹ need not fear cold weather, as in those regions it is always sufficiently warm.

The greater part of migrating birds set out from the north. During their flight they keep watch beneath them for lands or islands where they are most likely to find food. Once begun, their migration is to birds always the most important object in their lives, and to its successful completion, in spite of fatigue, hunger, and headwinds, they bend all their energies. They come to earth only when con-

¹ The tropics.

trary winds force them to rest from excessive fatigue and restore their strength, or when food becomes essential. Influenced by this instinct² they fly from one point to another, from island to island, until they reach the haven they have selected for winter quarters.

CHAPTER XXIII

ON THE WINTER QUARTERS CHOSEN BY MIGRATORY BIRDS AND THE REASONS FOR THAT CHOICE

The localities to which birds migrate (mainly to escape the cold weather) and in which they plan to spend the winter are of great variety;¹ some are remote and others less distant. Birds that nest in far northern latitudes or in regions within the seventh climatic zone are, as a rule, satisfied to migrate to the sixth or fifth zone, but may in turn abandon this region to go farther south. Birds born in the seventh climatic zone do not remain there throughout the year; if they reside continually in their birthplace they must not be classed as migratory birds. Birds migrating from the seventh to the sixth or fifth climatic zones (or beyond) find in these latitudes warmth sufficient for their needs in contrast with the intense cold of their native land from which they are retreating. The same holds true of species born in the sixth and fifth zones, the majority of whom are content

² Frederick would call it "hereditary or family experience."

¹ At this point in the Vatican Codex (at the end of fol. 16^v) there is a break in the subject matter, where a number of folios are evidently missing. The Bologna text and all its related six-book manuscripts are intact. The omitted passages will be found in Bologna MS. Lat. 419 (717), fol. 11^v, col. 1, l. 26, to fol. 17^v, col. 2, l. 37. The French translation (ca. 1300), Paris, Bibliothèque Nationale, MS. Fr. 12400, shows the same lacuna in chapter xxiii, thus furnishing evidence of the early loss of these folios from the Vatican Codex. In this translation the end of the lacunar passage will be found on p. 56.

to travel no farther south than the fourth and third regions, where the climate is mild enough for a winter residence. It is the same with birds born in the fourth and fifth zones; they migrate, as a rule, to the second climatic zone, or still farther south.

It must be borne in mind that the less hardy migrants are not equipped to withstand severe cold, hence they fly to more distant regions in search of a warm climate for their winter sojourn; among them are the cranes and storks, none of whom (with few exceptions) remain in the extreme north during the cold season or even in the seventh or sixth climatic zones. More hardy birds, like ducks and geese, can better endure the cold, and in consequence are content to migrate to less distant latitudes. They are satisfied to winter in a milder or more temperate climate than that of their native land. Again, birds that subsist on beetles, crickets, grasshoppers, bees, wasps, locusts (including the wingless variety),² and other insects,³ might be content to migrate to the fifth and fourth climatic zones were their food abundant in those regions at that season; but since the winter supply of their staple diet cannot be secured in these latitudes, they are forced to travel farther south, in search of food rather than for warmth. Birds that live on worms dug from beneath the surface of the ground do not remain in any region where the earth becomes solid,⁴ especially in mid-winter when it is freezing cold. These migrants, also, fly to more southern regions not so much because of the warmth they offer as to make sure of an adequate food supply.

From all this it is obvious that those cranes, herons, geese, ducks, and their like found throughout the winter in the sixth, fifth, fourth, and third climatic zones are not indigenous to those regions but have flown

thither from more northerly latitudes and, in some cases, from the extreme north. The majority of these last migrants are found in winter in the seventh and sixth zones, whereas most of the birds discovered in the fifth or fourth climatic zones came from the seventh, sixth, and more northerly regions. Birds observed during the winter in the third and fourth zones are probably indigenous to the fifth, sixth, or seventh zones.

It happens occasionally that in all these latitudes there are found in winter migratory birds that are residents of the region. They are those who, handicapped by disease or weakness, were unable to travel south (a fact to which we have previously alluded). We might add that few migrants that habitually shun the cold remain during the winter in cold climates; some are satisfied with the temperate zones, but the great majority seek a warm region. In fact, the closer we approach the equator, the greater the number of winter residents we find.

While all species of birds that fly south go there chiefly to enjoy a warmer residence, to provide themselves with food, and to enjoy safety and self-protection, they do not assume new functions during residence in southern zones. They do not, for instance, build nests and generate their young as do indigenous species who have no migratory urge. If migrants were to defy this law of nature and build nests, it would be time for them to start on their homeward journey before the young birds were strong enough. Moreover, at this homing season, in southern regions men are not planting vegetables and grains. Migrants therefore go north without delay to regions where millet, barley, leguminous vegetables, and grains are being sown. They tarry in a warm climate only so long as cold weather lasts in the north; and because the length of the winter varies from year to year, the winter sojourn of migrants is of uncertain duration.

² *brucos.*

³ *vermibus volatilibus.*

⁴ The Bologna text says *congeratur*; both the Mazarine and the Valencia manuscripts have emended this to *congelatur*.

CHAPTER XXIII-A

OF THE RETURN JOURNEY OF BIRDS
TO ESCAPE FROM SOUTHERN HEAT
AND TO BUILD THEIR NESTS

After discussing the migration of birds from cold to warm regions, to avoid cold, let us now consider their flight from warm to cold countries to escape the heat. We shall speak of this latter change of residence as the *return*; and refer to birds who thus migrate as *birds of the return*.¹ Let us first of all see which birds reappear in the land of their nativity and which do not, giving the reasons for the behavior of each group and furnishing an explanation of other aspects of their migration.

As a rule, all birds who migrate to warm regions return from them, with the exception of those that are in some manner incapacitated. Those, of course, who did not leave home cannot be spoken of as returning. In southern regions indigenous birds have a substitute for a northern return; they move to the hills or mountains and so escape the serious heat. After all, the most urgent and important factor in the return journey of migrants is the avoidance of excessively high temperatures. Indeed, birds enjoy a mild temperature; but undue heat dries up the waters, the vegetation, and even the earth itself, making it almost impossible for birds to find an adequate food supply. With failure of the water supply, a desiccated vegetation, and the baked earth, provisions fail and every aquatic, shore, and land bird is forced to return to a more northerly habitat. Birds of prey also are obliged to follow their food supply, the now returning nonrapacious species. Neutral and water birds have a different reason for flying north, viz., the disappearance of their chief means of defense—bodies of water.

A further reason for avian return is sex-

¹ *aves de reditu*.

ual; for birds, like every other being in which there are males and females, seek to reproduce their own kind for the continuation of the species; and they rarely build nests and raise a brood in their faraway southern winter quarters. Only indigenous birds who are born and nest there move for purposes of reproduction to a suitable locality in the neighborhood.

Birds prepare for the return when the conditions and time for leaving are propitious and, as a rule, in the following sequence: birds who have been feeding in haphazard fashion, sometimes singly, sometimes in twos or threes, gather and form larger groups, generally with birds of their own species. However, birds handicapped by disease or injury hold aloof from their fellows and live apart, although it might be wiser, for safety and common defense, if they joined the flock of migrants.

As the heat becomes more intense and lasting, these congregations of birds fly from place to place on their way north, but always prepared to fly still farther onward. They often tarry longer in one place than another while waiting for weather that will favor progress to their northern homes. Thus their return is accomplished in short stages from hot to cooler localities, always keeping ahead of the increasing heat. The more intense the heat, the greater their haste to depart.

Birds of prey are exceptions to the general rule in that they do not gather for the return with raptorial birds of their own or any other species.

Those birds that form flocks in preparation for the return are not as numerous as when they first migrated. Many of them have perished in storms, high winds, and hurricanes, during the southward migration. Others, during their winter sojourn in warm climates, have been trapped in nets or killed by other birds or by human devices. Moreover, since the mating season is not far off at the time of the return, those birds that feel the urge to

breed are not inclined to wait for the formation of such large flocks as gathered for the previous journey south.

Migrant birds know instinctively the season and winds most helpful for their return. When the sun begins to recede from the winter tropic² and approaches Aries, and when spring comes, they take advantage of the southerly winds which greatly assist their passage. When the spring is a dry one, without storms, contrary gales, or other adverse conditions, they reach their home readily, rapidly, and without accident. If spring sets in early, they also begin their northern passage early. When spring is retarded, they, too, are late in returning. They are always on the alert to take advantage of favoring conditions of wind and weather, as they were on their southern flight.

Birds of the return observe the following order: Those stronger species that were the last to migrate, such as all geese, are the first to begin the homeward journey. Following them in the order named we have cranes, storks, herons, quails, and, last of all, the smaller birds. The weaker herons of all species leave later than the stronger. The strongest herons, chiefly impelled by a desire to nest, return earlier than the others because they are best able to withstand the fatigue of the encounter with lingering winter weather.

As the time of migration approaches, weaker birds, in dread of impending winter, hasten their departure at the first inkling of freezing weather. Conversely, when the season for the return flight arrives, and the winter moderates in the north, the stronger birds fly away first, indifferent to the cold blasts that still persist in their northern habitat; while weaker individuals linger on for a time, fearing the remnants of wintry weather.

Birds that are wont to migrate from the

² Capricorn.

farthermost arctic regions start out early on their homeward journey, because they are conscious of the increasing heat and are less able to bear its intensity and because they have a long journey to make before reaching their native land. Migrants from less distant countries return later; they are better able to endure high temperatures and have a shorter homeward passage.

It is important to stress the fact that birds on the return do not observe the same order, nor do they always fly in the same manner, as on the outward journey; for the homeward flight is generally less systematic and is accomplished with less regularity than is to be noted in the first migration.

The regions from which birds set out on their return flight we have already described when discussing the places to which birds migrate, for they are identical.

Localities in which returning birds interrupt their journey (when they encounter contrary winds, halt to rest their wings, or descend to feed) are selected to meet specific needs; and they resemble or are about the same places that they chose on the earlier, outward passage.

The destination of most returning birds is their birthplace in the north. Furthermore, on their return to nest and brood, each species usually selects the region it occupied the previous year. It has often been observed that the nests of such nonrapacious birds as storks, crows, and other *corvidae* are tenanted by the same birds for many years in succession. This law applies also to the nests (commonly known as eyries) of birds of prey, and has given rise to the superstition that Accipitres have an unusually long life.³

³ The Bologna Codex reads, *multi putant hujus aves esse longevas cum non sint*, and the Valencia text is the same. The Mazarine manuscript says: *multi putant hujus aves esse idem genus cum non sint*.

CHAPTER XXIII-B

OF HOW THE MIGRATION OF BIRDS
COMPARES WITH THEIR RETURN

From the foregoing it is patent that the return of birds resembles their outward migration in some of its aspects, while in others it differs. The journeys are alike in that both are performed in search of moderate temperatures; and, in preparation for them both, birds gather in flocks of definite, single species. In both cases they await favorable winds and weather, and travel to distant lands. The initial migrating flocks, however, are larger than those of the return, and the first migration is more orderly. As they return for nidification chiefly, birds are more irregular in their flight and less concerned with others of their species. Many birds take more time for their outward migration than for the return journey, when the vernal impulse to breed drives them on. In order not to retard their nesting season they hasten their return even though the assisting winds are not as steady as those that carried them along on their journey south.

Migration is made not to fixed areas but to whatever regions afford them food, mild temperatures, and security. The return, however, is to the place of their nativity, where they have, perhaps, already nested. They know where they will find on the return a suitable environment and climate, as well as a good food supply for themselves and their nestlings. Furthermore, birds return in an order reverse to that of their migration.

Among other important observations is, as one result of the return, the extreme weakness of certain birds, resulting from severe exhaustion, a condition especially noticeable in the case of cranes. In the great plain of Apulia, a region called the Capitanata,¹ birds of this species that were taken by means of gerfalcones, falcons, and other birds of prey had

bloody down and quill feathers beneath their wings and on their flanks. They were so weak that they were hardly able to fly, and some of them were captured by the (unaided) hand of man, a circumstance we have not heard reported from other districts. We have not so far been able to ascertain whether these bloodstains were due to the cranes fighting among themselves because of the approach of the mating season, or to the fact that the mature birds had attacked their offspring to drive them off before producing another brood, or whether the extreme fatigue of the return had caused blood to flow from their nostrils so that when the cranes anointed themselves the feathers and down became smeared and stained with blood. Or there may be some other reason for this phenomenon.²

CHAPTER XXIII-C

WHERE TO FIND MIGRATORY AND
INDIGENOUS BIRDS

Birds that are migratory by instinct and habit (cranes, geese, and ducks) are much more plentiful than residents in cold climatic zones and in extremely northern latitudes (provided the particular area is one capable of sustaining avian life). In the middle zones the difference in numbers is not so marked. Northern lands possess an inexhaustible water supply that is promoted and conserved by the absence of the sun in winter and by the extreme cold. With the arrival of warmer weather (the period during which the return-

¹ The Capitanata. This name is a corruption of the title *Katapanos* (καταπανός) used to designate the Byzantine governors of a large part of southern Italy after its recovery, in the ninth century, from the Lombard invaders. It became attached to, and still is used to denote, a portion of Apulia conquered for the Normans under William Bras-de-Fer, and includes the great plain around Foggia.

² Note that this incident is again described in Book IV, chapter ii, p. 203.

ing sun passes through the northern signs of the zodiac), the snows melt and the water that is formed runs off into ponds, lakes, and rivers. The heat of a northern summer is not, however, so intense as to cause any serious diminution or evaporation of this water supply. In any event, water carried off by heat during the short summer is easily compensated by the rains that fall regularly at that time and by the snowfall of the succeeding cold season; for winter follows winter almost without interruption. As a consequence of these abundant supplies of water, both aquatic and neutral birds, whose chief refuge they form, and the raptorial (that prey on these harmless species) are more numerous in these far northern regions. When moulting, waterfowl are impeded in flight by the loss of feathers; they then find a convenient refuge and ample food supply in the teeming northern waters. And birds of prey when moulting and unable to fly well seek a readily acquired sustenance where avian fare is most copious.

Migratory land birds that nest in trees find in northern countries plenty of forests in which to make their homes and where they can most successfully secure food and protection from their enemies. In these regions they are to be found in considerable numbers; here, too, birds that live on worms are assured of a plentiful supply of their regular diet because of the prevailing rains.

Nonmigratory species such as partridges, pheasants, bustards, and species akin to them prefer the intermediate zones—the fifth, the fourth, and parts of the third. It may be accepted as a law of nature that all species of birds choose what to them is a temperate climate. This is especially true of species that are not equipped for long migrations. Residential birds are abundant at those latitudes where the temperature is uniform or at least does not cause them distress by undue heat or offensive cold.

Let us repeat, then, that nonmigratory birds are more numerous in the middle climatic zones. It must also be remarked that the more numerous the species of any particular genus, or the individuals of a single species, that migrate from a northern locality, the greater will be their numbers on their return to the north. This rule applies to aquatic and shore birds, as well as to raptorial and harmless land species.

CHAPTER XXIII-D

OF THE MATING OF BIRDS

It is not our intention to enter into a full discussion of the subject of avian reproduction, which generally takes place after the return of birds to their native haunts. It may be said, however, that the pairing of male and female is for the purpose of breeding. Pairing is a preliminary to coitus, which, in its turn, is followed by breeding. Mating is preceded by the abandonment of the now full-grown young that resulted from a previous union. This procedure is necessary because last year's fledglings, mindful of the food furnished by the parents, are not inclined to leave them until they themselves reach the age for mating or until they are otherwise prevented from following their parents or are actually driven off by them. Raptorial species not only expel their young in this way as soon as they can fly but drive them from the neighborhood, as will be explained later.

This method is not, as a rule, adopted by harmless species, who do not desert their offspring until they are again affected by the instinct to breed; meantime the young birds endeavor to follow and associate with their parents. Even those species that breed several times a year are accompanied by their fledglings, who are driven off only at the last moment.

In the case of birds that breed once only during the year, particularly cranes, the young birds follow their elders and are not expelled by them for a whole year. But in every instance fledglings are driven away and, if they are unwilling to go, the parents use force and even beat their offspring to prevent them from interfering with the new brood by destroying the nest, breaking the eggs, or killing the occupants.

Having abandoned their young and all others of their kind among whom they have been living, the full-grown birds now give themselves up to the business of mating, each male choosing a single female of his own species. This applies, of course, only to those species in which birds pair off for purposes of reproduction. There are, however, many races of birds where the male does not mate with a single female but is polygamous. The males of these species do not, as a rule, assist the females to build the nest, to incubate the eggs, or to feed the young; for example, those dark-colored birds called wild peacocks, a second black-hued species resembling a pheasant,¹ and many others, including certain varieties of quail, peacocks, pheasants, and bustards (nearly all nonmigratory varieties), make little effort to help the female in the tasks of nesting and of rearing the young. A few of these resident species are, however, monogamous—for example, the partridges.

All migratory birds, when they attain the proper age and have the desire to mate, pair off in the manner described and the male bird invariably assists his mate in some part of the many phases of brooding and bringing up the young birds.

We say "when they attain the proper age," because some birds (like the cranes who breed only once a year) do not undertake the business of procreation until after they are at least a year old, sometimes waiting until the second

¹ Probably the capercaillie and the blackcock, both species of European grouse.

year of life; others breed at the end of their first year, and these birds usually select their mates before the end of that year. These last are those that, like the pigeons, often breed several times a year.

We have emphasized the avian urge to mate because there are individuals who, though they are ripe as to age for reproductive activities, neither mate nor reproduce. They are prevented by some abnormal impediment from satisfying this impulse to perpetuate the race. Such birds are, as a rule, solitary; more rarely they are found in colonies.

As soon as birds feel the impulse to mate and reproduce, they select their partner in the following manner: They return to their native country, or to a locality that closely resembles it, if for any reason it is not available. At this time more than at any other, birds give voice to various cries, frequently singing and whistling. By these calls males and females recognize each other, and particular cries are indicative of a desire for coitus. Not only do males distinguish the notes of females, and vice versa, but each individual bird can identify its mate by the sound of his or her voice. When birds have made their choice, they pair off and usually forsake all others.

If a male loses his mate, he will endeavor to procure another female and if necessary will battle with any other male who disputes his right to a choice. Similarly, the female will adopt a second male once she has lost her own. Naturally a bird pairs more harmoniously with another of his or her own first choice.

The behavior of raptors is somewhat different from that of other migrants. One of a pair will be seen waiting for the other in the vicinity of their permanent nest or eyrie. Sometimes it is the male who first makes his appearance near the nest, where he may await the female for many days. In this same fash-



PLATE 49.—Adult hobby (*Falco subbuteo*, Linnaeus). (After Bowdler Sharpe)



PLATE 50.—Adult female merlin (*Falco aesolon*, Tunstall). (After Thorburn)

ion the female may be seen watching for her mate; or occasionally they arrive simultaneously² at the eyrie.

CHAPTER XXIII-E

OF COITUS IN BIRDS

Inasmuch as the pairing of birds at the period of the return ultimately ends in coitus, the laying and brooding of eggs, and the reproduction of the species, we would now discuss the minute details of the whole process and the attendant avian behavior if it were essential or in any way served our purpose; but as it is not relevant to the subject in hand we shall omit further discussion of it. There is, however, one fundamental fact that must not be overlooked. Nature in her endeavor to preserve the race by the continuous multiplication of individuals has decreed that every species of the animal kingdom, whether it progresses by the use of wings or walks on the ground, shall take pleasure in sexual union so that they may seek instinctively to bring about such enjoyment. Birds take such delight in this natural function that even birds of prey, who at no other time seek the companionship of their kind, not only come together at the mating season but even exhibit definite signs of mutual affection.

CHAPTER XXIII-F

ON THE NESTING OF BIRDS

Having touched lightly upon the subject of coitus, we now proceed to examine the second phase of its consequence, reproduction. This process may be divided into three stages: nidification, incubation of the eggs, and feeding of the young. We shall describe each of these three processes in its proper order.

² *similiter*. Cf. *Medieval Latin Word-List* (Oxford University Press, 1934).

When discussing nest-building we must consider which birds construct nests and of what type; those that build no nests; which birds nest earliest in the season; at what season they are most inclined to begin home-building, and in what localities; and how often during the year nidification is carried on.

Water, shore, and land birds, both raptorial and harmless, nearly all build nests. Each species knows instinctively the kind of nest best adapted to its own needs and the requirements demanded for the protection of the eggs and nestlings. Each species constructs a nest of a special design, yet all have at least one common feature: the interior is concave. This round cavity is essential for every nest so that it may serve as a satisfactory receptacle for the eggs (that are all spheroid). This shape also tends to preserve a certain degree of warmth within the cup when the mother bird sits on the clutch and, also, to force the newly-hatched youngsters to nestle close together and so keep warm while the mother bird is absent. Finally, it prevents the nestlings from falling out of the nest.

Birds that employ no materials in nest-building commonly dig a hole in the ground and heap up the earth around the cavity, thus providing a warm and solid resting place for their eggs. Among the birds that fail to build nests but lay their eggs on the bare earth are the great and little bustards.¹

The bird commonly known as the cuckoo neither builds a nest nor lays its eggs on the ground (nor does she ever feed her young), but deposits her eggs in the nests of other birds, such as blackbirds and others of this type.² These foster parents hatch the cuckoo's eggs and feed the young until they reach maturity. We have verified this fact from actual experience. A nest of the small bird known

¹ *bistardi et anates campestris*.

² *in nidis merulorum aut praeneorum aut aliarum avium*.

as *praeneus*³ was once brought to us for inspection. In the nest were the young of this bird together with a diminutive creature of dreadful, misshapen aspect that offered no resemblance to any avian species. This featherless mite had an immense mouth and was covered with long, thick hair-like down over its whole head, obscuring its eyes and beak. That we might eventually establish the identity of this strange nestling we fed it carefully along with the other young birds; and, behold, on maturity we saw that it was a young cuckoo. By this experiment we established the fact that these birds do not build nests of their own but make use of those of other birds in which to lay their eggs.

As a rule birds take great pains in selecting the material used in the construction of their nests. They choose whatever is best adapted to their own requirements and to those of their eggs and young. These substances they join and weave together with such delicacy and in a fashion so intricate that no human artist can hope to equal it. It would take hours to describe the diversity of materials used by birds and the methods adopted by them in building their multiform nests.

All birds that migrate to far-distant lands build their nests early in the season so that their young may become strong and equal to combating the rigors of the autumn migration. Resident birds, or those that travel short distances, usually build later than other migratory birds. It may also be said of all water, neutral, and land birds, either rapacious or nonrapacious, that their early or late nesting depends largely on the supply of food, as well as on their characteristic differences in warmth and humidity and the extent to which they are influenced by the planet Venus.

For a variety of reasons⁴ birds generally

³ It has not been possible to identify this bird; it might be any one of a number of species.

⁴ The Bologna manuscript says *cavans*, but this is emended in the Mazarine text to *causas*.

nest in the springtime. This season has, as a rule, an even temperature, which induces an abundance of blood and sperm, and an excess of these two humors arouses a desire in both sexes to indulge in coitus, resulting in racial reproduction. Furthermore, spring is followed by summer, a more favorable season than any other for rearing the fledglings. Birds need considerable time to build their nests, lay their eggs, and incubate them. The subsequent task of bringing up the young until they have grown feathers and learned to fly, have become self-supporting, and are able to protect themselves from danger also requires time. Birds that feed on fish and other aquatic animals find this food more readily and in greater abundance during the spring and summer months when fish rise to the surface of the water to feed. All those avian species that live on all sorts of locusts, crickets, and every kind of worm and insect find springtime particularly convenient for nesting because of the longer period afforded for educating their young.

If the objection be raised that autumn, owing to its even climate, would be equally propitious for nesting, we reply that if birds were to nest and breed at that season severe winter weather would damage the nest and injure the fledglings before they were mature and feathered and had become accustomed to the cold. Delicate and naked, they could not protect themselves against frost and rain. Moreover, were birds that migrate to the distant south to produce their young in the autumn, the fledglings would not be in condition to leave but would be obliged to winter in cold latitudes under conditions that might prove fatal.

These are the chief reasons why most birds nest in the spring rather than during other seasons. They do not, however, preclude the possibility of certain species nesting at other times of the year, especially during the summer.

Birds select sites for nidification suitable to their own needs and those of their young. Among requisite features for a proper breeding ground is a sufficient food supply for them all in the close vicinity of the nest. If the parents were obliged to hunt for provisions at a distance, some mishap might befall the occupants of the nest during their absence—perhaps death or robbery of the young. Sites are chosen, also, that afford the maximum security and concealment, so that the parents may feel safe from the depredations of weasels, cats, foxes, men, thieving kites, snakes, and other predatory or dangerous animals. We find, as a rule, that the weaker the bird the more secret and secure from danger is the position of her nest.

Land birds nest in trees, brambles, and shrubs, in holes made by other birds,⁵ in the crevices of cliffs, on the ground in thick grass and in the furrows of plowed land, in lofty bluffs overhanging rivers, in human habitations such as on housetops, in holes in walls, and on towers. Birds of prey nest in wind-swept treetops, in caves, and in clefts on the steep faces of high cliffs, as we shall describe in our treatise on birds of prey.⁶ To classify and describe the nesting places of every land species would require much time and occupy much space.

Water birds nest, as a rule, on islands situated in the ocean, in lakes or in large rivers, in swamps in the midst of quiet waters, in the depths of reed beds, and in other sites in proximity to water.

Shore birds (that in general exhibit the traits of both land and water birds) when more decidedly aquatic nest nearer the water and so emulate the latter in this respect, while those more resembling land species incline to build their nests some distance from bodies of water.

⁵ I.e., in tree trunks.

⁶ *Ut in tractatu de rapacibus dicitur.* One wonders whether Frederick II was referring to an entirely new work or to the second book of his monograph.

Although, as we have mentioned, water birds usually nest on aqueous bodies, there are those that nest in trees growing in swamps or at the water's edge. For example, herons, especially the buff-colored and gray species, not only build in such lofty trees as the oak, beech, pine, and elm but, when there are no such high and robust trees close at hand, may nest on the ground. They avoid smaller and more slender growths such as willows and tamarisks and seek, by preference, impassable and muddy canebrakes where they make their nests among the reeds. Willows and other low growths are more accessible to men and snakes than are the marshy reed beds. In building their nests herons select the higher stalks growing in remote parts of the swamp. They weave together the tops of a group of contiguous reeds and on this foundation or platform construct their nests.

There are certain large wild geese resembling their domesticated relatives whose nesting places in the fifth, sixth, and seventh climatic zones are known to us. We do not, however, know the exact localities chosen by smaller species⁷ because they nest in such remote, inaccessible regions of the extreme north.

There is, also, a small species known as the barnacle goose, arrayed in motley plumage (it has in certain parts white and in others black, circular markings), of whose nesting haunts we have no certain knowledge. There is, however, a curious popular tradition that they spring from dead trees. It is said that in the far north old ships are to be found in whose rotting hulls a worm is born that develops into the barnacle goose. This goose hangs from the dead wood by its beak until it is old and strong enough to fly. We have made prolonged research into the origin and truth of this legend and even sent special en-

⁷ Nor were we certain until comparatively recent times of the location of these nesting grounds in northern polar regions, Spitzbergen, Greenland, and northwestern Siberia.

voys to the North with orders to bring back specimens of those mythical timbers for our inspection. When we examined them we did observe shell-like formations clinging to the rotten wood, but these bore no resemblance to any avian body. We therefore doubt the truth of this legend in the absence of corroborating evidence. In our opinion this superstition arose from the fact that barnacle geese breed in such remote latitudes that men, in ignorance of their real nesting places, invented this explanation.

The nesting places of plover and many other species have never been revealed to us, although many of them that nest in far-distant lands make their appearance among us during their migratory flights.

In discussing the number of times during the year that certain birds nest and reproduce, it may be said that those species that more closely resemble domestic fowls nest several times a year; their abundant nutritive supply and the warm climate in which they live remove the necessity for migration. They are also well supplied with sperm-producing substances and are therefore warm-blooded by disposition; they, therefore, indulge in frequent coitus. Examples of these are the gallinaceous species, sparrows, and pigeons, all of whom nest several times a year and lay eggs in large or small clutches. In fact the pigeon breeds regularly every month.

Such wild birds as ducks, cranes, and quails nest, at the most, only once during the year. Their food supply is scarce and, owing to their active and industrious mode of life and migratory needs, they are unable to nest even twice annually, particularly in cold countries. Birds who normally nest once annually but for some reason lose their eggs or newly hatched young often endeavor at the earliest date possible to produce a second clutch, either in the same or in a freshly constructed nest. This accident explains their unusual second breeding.

CHAPTER XXIII-G

OF THE LAYING AND INCUBATION OF EGGS

We pass now from the subject of nest building to the laying and incubation of birds' eggs. To begin with, we cannot give here exact data as to the number of eggs laid by a given species, since the figures would be too numerous and too diverse to record. The following facts must not, however, be overlooked. Cranes and other large birds, such as swans, pelicans, bustards, and vultures, whether land or water species, lay few eggs, since the greater part of their food is consumed in flesh-building, required by the bulk of their bodies. Vultures in particular lay a small quota of eggs. In several instances we have inspected nests in which there was but one solitary egg which was being incubated alone. Aristotle, however, in his book on animals, states that neither the nest nor the young of vultures have ever been seen.

Smaller birds lay a large number of eggs in proportion to their size. Being slight of build, only a small percentage of their food is needed for bodily support, while the remaining and larger portion is changed into sperm and egg-building material. This rule applies also to the breeding of quadrupeds; the larger ones produce small litters, whereas the smaller animals beget a numerous progeny.

It happens occasionally that birds lay eggs without direct contact with the male, but such eggs are sterile¹ and none of them reach fruition. Illustrations of this fact are seen in hens, pigeons, geese, ducks, and peacocks, both domestic and wild. It frequently happens, also, that raptorial birds lay sterile eggs, especially those falcons that have been confined to the mews and have not been flown during the winter but allowed to remain idle and rest until spring.

¹ The manuscript reads *sunt ova venti*.

The shells of birds' eggs are of infinite variety in color (depending upon their species). Some are all white, or white with spots; and the spots vary in color and shape. Eggshells may be grayish, green, blue, and many other shades. Expert ornithologists can often identify a bird as soon as they see its eggs.

The eggs of those aquatic birds that nest near and feed in the water and along the shores differ from those that live and procure their nourishment in dry meadows in this respect—they contain double the amount of yolk in proportion to the white. This statement does not hold true in the case of land birds.

The shape of birds' eggs also varies with the species; some eggs are more nearly ellipsoidal than others that are rounder. Most eggs correspond to the corporeal lines of the bird that laid them and of the bird that will ultimately be hatched from them—elongated eggs for the slender birds, round ones for the more stocky species.

As regards the actual incubation of eggs, in certain species the female alone sits on and keeps them warm, and never the male. This is, as a rule, true of species that do not pair prior to reproduction, and when the male does not assist the female in nest building. Among such birds are fowls, bustards, and peafowl. In some species, e.g., pigeons, both male and female take turns in sitting on and keeping the eggs at an even temperature. This is generally true only of species who pair to propagate the race and where the male joins in nest building. Birds of a warm nature, who are aided by fine weather and other favorable circumstances, brood their eggs for a shorter period than do those of a cold temperament who do not enjoy such advantages. Furthermore, males of certain species, although they do not directly help the females with incubation, supply her with food and so render unnecessary her forced absence from the nest.

We have already alluded to the fact that the cuckoo does not incubate its own eggs. The same is true of the ostrich, whose failure to perform this function we ascribe to fear of breaking the eggs by subjecting them to the weight of their large bodies. Moreover, the extreme heat of the sun, warming the sand in which the eggs are deposited, is sufficient to hatch them. A similar phenomenon is to be observed in Egypt, where eggs of the barnyard fowl are kept warm and the young hatched out independent of the mother bird. We ourselves saw this, and we arranged to have it repeated in Apulia by experts whom we summoned from Egypt.

Chicks are not hatched from every incubated egg, for a number of the latter are destroyed by wind, lightning stroke, and other agencies and accidents. Sterile eggs, of course, bring forth no young, since they lack the activating male spermatozoa.

A discussion of the manner in which the embryonic chick develops within the egg, the order of appearance, and the formation of its various organs and members, the most suitable season and the length of time required for incubation, as well as numerous other constant factors, we omit here because they all have been adequately discussed in the *Liber Animalium*; nor are they relevant to our main subject, which deals chiefly with methods of teaching full-grown raptorial birds to capture well-developed nonraptorial species.

CHAPTER XXIII-H

OF THE CARE AND FEEDING OF NESTLINGS

Let us now discuss the feeding and other care of chicks after they emerge from the incubated egg, including such questions as which of them are at once able to run after the mother bird and which are not; also which

parents feed their young and which do not; where the food is found and how it is carried to the nest, its variety and the manner of feeding it to the young; whether the parents feed first themselves or their young; how fledglings are expelled from the nest; the adroitness with which adult birds defend their brood; and, finally, what species associate longest with their offspring.

For reasons already stated it is difficult to formulate rules to decide what species hatch most quickly and which most slowly from the egg, or to specify the exact time and number of days required for incubation, for the period is not the same for all species. We now return to our first topic.

Many young birds, as soon as they emerge from the egg, follow the parent birds about and feed themselves, the adult birds clucking and scratching up seed for the youngsters.¹ Among these are chickens, the young of quail, partridges, starlings, pheasants, peacocks, and numerous other land birds.

Similarly, among the newborn of aquatic birds those that are swimmers are not fed by the parents but as soon as they are hatched follow them to the feeding grounds. These last two classes of young birds are so well developed and so strong at birth that they do not need to be fed by the mother but at once follow her about and look out for themselves.

Among the nestlings that do not follow the parental trail as soon as they break the shell, but need to be fed, are the young of birds of prey and, in general, all those species that build their nests in lofty places. This form of feeding is necessary if for no other reason than that, were the offspring (usually featherless and hatched high above the ground) to leave the nest in search of food, they would fall and in all probability be killed. In these species, almost without ex-

ception, either the adult male or the female stands constant guard over the eggs.

Birds that do not feed their young are numerous, and in some species neither the male nor the female parent feeds them; for example, the cuckoo and those birds that immediately lead their offspring to places where they know suitable food is to be found.

The female of certain species feeds her brood alone, and this is usually the case when the mother bird has not been helped by her mate in building the nest or in incubating the eggs; she assumes the entire burden of feeding the nestlings. There are also certain species of which both male and female provide their young with food; but the mother is usually the more diligent in that respect. As a rule, all males who really help the female to incubate also assist her materially to feed their offspring, e.g., pigeons, turtledoves, ringdoves, and similar species.

Generally speaking, birds feed their young on the same fare they themselves consume. We have described these foods in our chapter on avian provender.²

Birds carry food to their offspring in the stomach, as do storks and members of the heron family; in the throat or gullet (crop), like pigeons, turtledoves, and other kinds of doves; in the mouth, concealed under the tongue, like ravens, crows, magpies, and other corvidae; in the beak, like wood larks, starlings, and numerous other small birds; and, finally, in their talons, as do birds of prey.

As to the manner of feeding their young, birds that transport food in their stomach generally spew it at the feet of the youngsters, who then gorge themselves with it. Those who carry the food in their crop insert the beak between the mandibles of the fledgling and empty the grain and other contents of the gullet directly into the young bird's throat. Vultures vomit the contents of their crop in front of their young, who there-

¹ The Bologna manuscript says *scalpunt eos* [i.e., *pullos*] *et carminant grana*. To clarify this sentence we have reversed the order of the verbs.

² Cf. Book I, chapters ix, xii, and xv-a.

upon seize upon and consume it. Those who carry food in the mouth drop it straight into the mouths of the nestlings. Those birds that arrive with food in their beaks, although they are, as a rule, seed or grain eaters, do not feed their young with cereals because it would be extremely difficult for them to eject such food from their crops and, on the other hand, it would be a very laborious undertaking to return on each journey with but a single grain. Consequently they catch and bring to the nest locusts, crickets, worms, and similar fare that is more satisfactorily handled. This method is continued until the youngsters are able to follow the mother bird and find their proper diet of grain and seeds. Those birds who bring food in their claws place it in front of the young ones and, after tearing it to shreds, thrust morsels between their mandibles.

Newborn starlings, blackbirds, wood larks, and other nonraptorial nestlings who, at birth, are unable to defecate outside the nest secrete a tissue-like glue that adheres to and coagulates about their excrement. These droppings the parent birds pick up in their beaks and eject from the nest, without defiling their own mandibles, because, as we have said, the dung is covered with a glutinous pellicle. As soon as these young birds are strong enough they learn to hold their rump over the edge of the nest and mite outside, like other fledglings, and so do not foul the nest.

Birds of prey³ feed their young before they consume their own share of food. This they do that they may be lighter and in better condition to accomplish the task of securing food and making repeated journeys to the nest. Hunting in itself is onerous enough, without the additional handicap of a heavy meal that would render their hunting more precarious and therefore harmful to their young. As regards nonrapacious species, we cannot say definitely whether the parents feed

themselves or their young first or consume their food simultaneously.

The solicitude and cunning with which adult birds defend their young is plainly shown in a number of ways. This safeguarding of their offspring is inspired by a great love for them; they even interpose their own bodies to protect their young from impending danger and may ward off a multiple attack by rapacious birds or other species threatening to seize their offspring. It is noticeable that while rearing a brood the parent birds lose weight from anxiety in carrying on the difficult task of securing sufficient food for the family.

We have observed the following protective maneuvers adopted by ducks and other nonraptorial birds whenever a stranger approaches their nest. They feign illness or injury, and pretend they cannot fly. Flying weakly a short distance from the neighborhood of the nest, eggs, or young, they try to give the impression that their wings or legs are injured. For that purpose they simulate a fall on the ground to encourage the trespasser to follow and capture them. As he draws near to seize them, they little by little retreat, pretending weakness as before and encouraging the enemy to persevere in his pursuit. When they have enticed him sufficiently far from the (eggs or) loved ones, they rise in full flight and make off. To this performance (enacted to divert the trespasser from stealing their eggs or young) are added other ingenious stratagems that are readily observed by anyone who wishes to investigate this interesting occurrence.

Generally speaking, the young of nonrapacious birds (both of those who feed their young and of those who lead them immediately to the feeding grounds to fend for themselves) follow their parents for a year, or at least until the second nidification. Then, however, the fledglings are buffeted by the mother and driven away. We have already explained the reason for this act.

³ See Book II, chapters ix, x, xi.

Birds of prey actually feed their young for a longer period than do many non-raptorial species but drive them off sooner to look out for themselves. Were raptorial adults and their fledglings to hunt in company, parents and young would prove no exception to the rule that birds of prey rob one another of their quarry. Injuries would follow on each side, and an unhappy state of affairs would result. Therefore it is essential for the mother bird to expel her brood in early life and thereafter "walk alone."⁴ It may be added that although raptorial birds, with few exceptions, take little or no care of their young after they are full-fledged (not waiting a whole year or even for a second nidification before abandoning them), the offspring, remembering the nourishment they have received from their parents or have found with their assistance, and mindful of their daily intercourse, attempt to follow the adult birds longer than the latter care to have them.

A raptorial mother takes her young from the nest, teaches them to prey for themselves, and as soon as that is accomplished drives them away. Her procedure is as follows: When the nestlings have reached a certain age and acquired sufficient vigor, the mother brings them a dead bird and teaches them to deplume and feed upon it. This act is repeated several times until they have learned their lesson. She then fetches a live bird that she herself has partially deplumed, so that it is unable to fly with ease. Showing this prey to her offspring, she permits it to fly off as best it can, instructing the fledglings to follow it. If one of the young birds succeeds in capturing it, she recalls the others, allowing the successful hunter alone to feed upon the quarry. If the deplumed bird escapes, the mother pursues and captures it and releases it once more in the presence of her young. As soon as one of the fledglings succeeds in

⁴ *Solitarie ambularent.*

seizing it and in killing and eating the deplumed prey, the parent bird prevents the other young ones from interfering with their more successful brother. In this way birds of prey teach their fledglings not only to fly but little by little to hunt. While still weak and until the youngsters learn to recognize a bird, they are taught to hunt and eat such small quarry as locusts and other insects that they see flying about the eyrie. When such young birds are captured and examined, their beaks and talons furnish evidence of this dietary.

After the fledglings have learned to fly and to hunt avian prey, the parent drives them away not only from the immediate neighborhood of the eyrie but from the entire nesting locality. Were the mother and her offspring to continue to hunt in the same territory their avian quarry would take fright and there would soon be insufficient food to supply the needs of the whole family. Also, as previously stated, were an adult bird to make a capture, the now full-fledged young would not hesitate to rob her of it or to steal one from another.

The outlaws thus separated from their parents and from each other now settle down to live their solitary lives, hunting locusts, crickets, beetles, small birds, and four-footed animals, capturing more and more of the latter as cold weather gradually destroys insect life.

CHAPTER XXIII-I

OF THE FUNCTIONS OF AVIAN ORGANS

We have discussed, to the extent required of us, the reproduction of birds. We shall now consider various external and internal organs that distinguish birds as members either of a species or of a genus.

Structural differences¹ the young bird in-

¹ At this point ends the long lacunar passage (missing from the Vatican Codex after fol. 16^r), see p. 40.

herits chiefly from his ancestors. If all birds were uniformly constructed, their members would exhibit in detail a corresponding uniformity of function, no matter how many species were represented; but avian organs show a great diversity in form and appearance, so much so that individuals may be distinguished one from another. These variations are at times so marked that they at once divide bird life into various categories.

The avian body, like that of any other aquatic and terrestrial animal, may be divided into cellular (homogeneous) and organic (functional) parts.² The cellular parts are those that are constructed of similar elements, like bones, cartilages, nerves, the cardiac ligaments, blood vessels, flesh and fat, and the tissues of the skin, feathers, and nails. We shall say little concerning each of these substances, merely mentioning them when we discuss the nature of the organs of which they form a part. The internal organs of birds do not vary greatly from one species to another in their component tissues.

The functioning organs of birds are constructed from various cellular groups. They are, however, distinguishable from one another in build, size, number, and location. Some organs, chiefly external, are of a sensitive (nerve-possessing) nature, while some internal organs are insensitive. It is by means of both these organic structures that birds perform the functions essential to their well-being, to the preservation of the species, indeed to the very existence of the individual.

One should not conclude that the functions of the members determine their conformation, since that would be to attribute the cause *a posteriori* rather than *a priori*. Organs come first,

according to their nature; then their characteristics, which are manifested through action and function, just as action depends upon the objective. As functions are determined by characteristics, and characteristics are derived from members, obviously functions depend upon organs.

It must be remarked that creative power has allocated to the proper place material naturally adapted to the formation of various organs and has endowed each one with a construction resembling that of the parent bird. Hence every organ is made of material suitable to its function as well as having a functional purpose. Moreover, if productive Nature had formed organs to fulfill the functions for which they are appropriate, it might be predicated that she made one bird that it might destroy another, viz., a predatory bird that would destroy and live on a species that is nonrapacious; in other words it would follow that Nature has created one species for the annihilation of another, and, according to this axiom, Nature is not only benevolent in one species and malevolent in another but, what is more important, exhibits her two opposite aspects at the same time, for each species finds in another what is harmful to it.

It must be held, then, that for each species and each individual of the species, Nature has provided and made, of convenient, suitable material, organs adapted to individual requirements. By means of these organs the individual has perfected the functions needful for himself. It follows, also, that each individual, in accordance with the particular form of his organs and the characteristics inherent in them, seeks to perform by means of each organ whatever task is most suitable to the form of that organ.

The external parts of birds that are of a sensitive nature are chiefly the head, eyes, ears, nasal cavities, mandibles, shoulder blades, joints, sides, belly, rump, hips, shin-bones, feet, toes, back, thighs, external breath-

² The terms *consimilia* and *officilia* conform closely to the modern "tissues" and "organs." Tissues, *consimilia*, are made up of primitive cells disposed in various ways to form bone, cartilage, connective tissue, etc. From these *consimilia* are constructed the organs of the body, the *officilia*.

ing apparatus, tail, oil glands, and other related parts.

The internal organs are the meninges, the brain, the vertebral canal, the tongue, other parts of the mouth, the bronchial tubes, lungs, heart, cardiac ventricles,³ diaphragm, esophagus, larynx and vocal cords, intestines, stomach, spleen, liver, kidneys, testes, uterus, and many other organs.⁴

We shall now discuss this list of both internal and external avian organs (by which birds consume their food and digest it and by which they avoid dangers, live in their dwelling places, fly about in space, and change their habitats) and shall include matters that it is necessary to study for the purpose of writing about the treatment of their diseases.⁵

Indeed, birds have particular organs for definite functions, examples of which are many. One organ may serve a single or more than one purpose; or several organs may be required to carry on but one function. That we may avoid needless prolixity in our discussion of these topics we shall mention only those organs and functions that are pertinent to our thesis, beginning with the bird's head.

The head contains the brain and the organs of special sense. It is constructed of many bones that form the skullcap. It includes tissues and nerves that govern the sense organs and motor apparatus. The head contains also the coverings and other parts of the organs of special sense, the eyes for sight, the ears for hearing, the nose for smelling, and the mandibles and tongue for taste. It occupies the chief and most important situation in the body because it is the seat of and

³ *casula cordis*.

⁴ The clear-sighted, remarkable, and correct explanations given by the Emperor of the terms *consimilia* and *officilia* are in marked contrast to some subsequent applications of these two terms when he, as may have been noticed, confuses the one with the other.

⁵ Frederick never, so far as we know, contributed a chapter on avian ailments and their care. We have several times referred to this unfulfilled promise.

controls its most important, finest, and most essential functions.

Various species, often the same genus, present great diversity in size, appearance, number, and position of the parts composing the head. Long- and short-eared owls, plover, lapwings, and some other birds have large heads in proportion to the rest of their bodies. Vultures, bustards, pelicans, swans, and many others have comparatively small heads. Other birds, again, have heads well proportioned to the size of their bodies, for example, hens and pigeons. Certain birds, like geese and swans, have elongated heads, and there are individuals that have longer heads than others of the same species. Other species such as rapacious birds and those related to them have more or less short heads. Some birds have a nearly round head, like curlew, lapwings, and plovers, as well as those that dig worms out of the ground, who, though they possess long bills, are none the less round-headed.

Some species have the head bare, others are well clothed with feathers, while in other instances the head has neither down nor feathers, as is the case with the black vulture (*galeranus niger campester*), which has a black beak and black legs, and the piebald (black and white) vulture (*galeranus varius ex albo et nigro*), which is frequently found in Syria, Egypt, and the Far East. This last-named bird has the whole head and throat naked, having neither down nor feathers. In some white species of carrion eaters that have black feathers at the extremities of their wings the saffron yellow of the mandibles extends to the middle of the head.⁶

Cranes have no true head feathers except a few hirsute appendages on the crown. Certain vultures, particularly the white variety, have some down on the head but no developed feathers. The majority of birds with feathered heads have no crests; others are crested.

⁶ This is the Egyptian carrion vulture (*Neophron percnopterus*). Other vultures cannot be identified.

These head ornaments may be thin, fleshy, or tuberculated; as in fowls that have red combs and are provided with wattles at the throat like beards, or such as one sees on the heads of certain water birds called Pharaoh's ducks.⁷ These are white and black geese, with red beaks, legs, and feet. Between nose and forehead they have a small, red, and fleshy excrescence, but it is not so protuberant nor so notched as is the cock's comb. The same condition is noticed in the male of a certain species of swan⁸ with red mandibles that, between the nasal openings and the forehead, shows a red, fleshy swelling, like a hazel nut,⁹ also called a "comb." Other birds sport a crest of feathers, among them the hoopoe, the horned lark,¹⁰ and certain parrots imported from India.¹¹ One of the latter was sent to us by the Sultan of Babylon; it had white feathers and quills, changing to yellow under the sides.

Some birds, such as herons, have projecting from the center of the head long feathers that reach to and lie like thick hairs along the back. A kind of bustard found in the desert has a high crest on its head extending to the back, like a mane. Other avian heads have

tufts of feathers to the right and left like horns, as seen in some pheasants, the great horned owl, and the short-eared owls; and still others sport tufts of this sort and in addition other feathers pendant from either side and from the throat, like a certain species of civer.¹² There are still others that have three feathers that hang down from the middle of the head around the throat like a beard. These feathers are more plainly displayed during the breeding season and when the bird is frightened or angry, for then they bristle. These bridal plumes are more abundant and in marked evidence during the spring.

There are also birds that have a horny protuberance (or helmet) on their heads, like Indian fowl; or they present in the same situation an indurated growth like their own spurs; sometimes (though rarely) there are two of these horns. Other peculiarities about the head call for little or no consideration in this short review.

CHAPTER XXIV

OF THE EYES OF BIRDS

The eyes are the organs and instrument of vision. In the *Liber Animalium*¹ it is fully explained why birds have two of them, why they lie in front² of the head, why they are placed higher in the body than other sense organs, and why they are composed of three humors and seven coats. By means of eyesight an animal correctly perceives dangers, sees objects he needs, and is able to avoid the one and to search for the others. The eyes

¹ Schneider says that this *Liber Animalium* was probably written by the Emperor himself and then lost. It was not a reference to the work of Aristotle, since the latter has not given us any definite description of the avian eye.

² The author says "*in proa capitis.*" Schneider remarks that most of them are laterally placed; rarely (as in the owls) do they look directly forward.

⁷ *anates de faraone*, the *Vulpanser tadorna*, according to Schöppfer. The coloration changes in this species. The male develops during the breeding season a brilliant excrescence on his beak. The expression may easily refer to the Red-crested Pochard (*Netta Rufina*) a species common in Lower Egypt.

⁸ Swans are difficult to identify, but perhaps the red-beaked and red-knobbed swan may be the spur-winged goose (*Plectropterus rupelli*, *Sclat.*), whose habitat is North Africa. The male has a rather well-marked knob on the beak. The bird does not present the usual anserine form, although he has a rather long throat. Doubtless during his many journeys in the Orient the Emperor had often seen this goose.

⁹ *avellana*.

¹⁰ The manuscripts say *cozardi*.

¹¹ These cannot be modern Indian birds, since the "parrots" mentioned are cockatoos and they are not found in India. The Sunda Islands is the nearest habitat of these birds. Legendary descriptions of these Indian birds are very doubtful. The title "India" was (in medieval times) often applied to any unknown country.

¹² The grebe (*Colymbus vel Podiceps cristatus*).

vary greatly in size, color, and shape. Some birds have large eyes in comparison with their bodies, some small, some of medium size. Certain birds have quite black eyes, like the falcons. The blackness of the pupil is deeper than that of the margins of the iris; some dark pupils have a blue-gray border, as in the genera of hawks and sparrow hawks.³ The color of the eyes may vary with the age of the bird.

Among hawks and sparrow hawks there are some individuals that have very dark eyes, like falcons. Often both eyes are black, but occasionally one only. Falcons, however, never have either one or both eyes the same color as hawks' eyes. It appears that the black pupils of the latter bird's eyes are enlarged when they are fixed upon some object and diminished when not staring at something that draws their attention. Some birds, moreover, see better than others.⁴

Most birds shut the eyes by the aid of the lower lids, which are long and adjusted to the purpose; in some others both lids take part in closing the eyes. Avian lids are devoid of true hairs or lashes.⁵

For cleaning the eyeball there is provided a peculiar membrane that is quickly drawn across its anterior surface and rapidly withdrawn.⁶ The many peculiarities of the eye cannot (all) be described here. The superciliary shield that projects forward as a protecting wall over the eyes is, in birds of prey,

³ The Emperor is astray in his description of the color of the eyes of rapacious birds. Falcons have usually brown irides, and common hawks and sparrow hawks have yellow, not blue-gray, eyes. The iris is often gray in the brightly colored mouse-bustards and silver-gray, verging on yellow, in the red kite. The author is referring, of course, to the European sparrow hawk, which resembles our Cooper's hawk but is smaller.

⁴ The whole of the foregoing paragraph (the statements of which are not quite accurate) is found only in the Bologna and other six-book manuscripts.

⁵ Birds' lashes are not hirsute but are in reality small feathers.

⁶ This skin is called the nictitating membrane.

bare and lacking in feathers; it is so stiff and thin as to have almost a cutting edge; in certain other birds it is less prominent but feathered.

CHAPTER XXV

OF AVIAN EARS

The hearing apparatus lies within two apertures situated behind the eyes toward the back of the head. Two canals in the bone (twisted internally like a wine-press screw) are found, one on the right and the other on the left side. As a rule they have externally no cartilage, commonly called the auricle, or lobe of the ear. This attachment is found only in eagle (or great horned) owls, the eared owls, and a certain species called the *uhan* (long-eared or screech owl).¹

These birds have around the opening of the ear a skin (membrane) which, when drawn back, resembles (corresponds to) the external lobe of the human ear. The circumference of the ears is in some birds clothed with a few feathers and in others with stiff hairs. The ears are used only for audition; from the sounds he hears the bird decides whether they forebode good or evil.²

CHAPTER XXVI

OF THE NOSTRILS, THE MANDIBLES, AND THE SHOULDERS

The nostrils are two openings placed close together and on the same level in the upper part of the beak, through which birds breathe, perceive odors, and expel waste moisture. Each of these openings has two canals, one supplied to the head, the other to the palate.

¹ French, *Chat huant*.

² *delectabile vel detestabile*.

In the palate they join to form one passage that is connected with the bronchial tubes.

Birds' nostrils vary in form; some are round, some long and perforated—as in waterfowl. There is an intermediate cartilage between the two anterior openings, or a small fleshy elevation inside them, that projects in certain species, in falcons for example. In other birds it is turned under and lies beneath, as seen in hawks. These small excrescences are absent altogether in some species, while other birds, like the ravens, have in place of them stiff hairs that conceal the nasal openings. Now and then one finds that in some birds the nostrils are uncovered, while still other species have inside a spiral (cochlear) arrangement like the shell of a snail. Some do not show this snail-like condition but possess a straight canal. In fact birds have many forms of nostril.

A careful observer will notice that there are other peculiarities about the nasal cavities, e.g., internal, fleshy tubercles. There also exists in some instances, between the nostrils and the eyes, a soft spot (cere) in the beak which yields to the touch. This area is covered by one membrane and beneath it lie two more, one above the other. Under them lies a canal¹ that runs from the nose to the brain and drains the fluid from the latter, as does also the other passage that connects it with the palate.

The beak is a horny member used chiefly in eating. It consists of two segments, the upper and the lower mandible, which in birds is a substitute for jaws and teeth. The upper mandible is joined to the palate; and the tongue, although not directly connected with the lower mandible, lies above and on it. Birds move their lower mandible upward and the upper mandible downward whenever these movements are necessary for them, although Aristotle maintains the opposite belief; at any rate other motions are rare except in rapacious birds and parrots.

¹ The lachrymal canal.

The mandibles are employed chiefly for feeding purposes, for swallowing, for oiling the feathers, and for scratching (the body) where it itches and where it can be reached. They are also employed by the bird to defend itself against attack. It is by means of the beak that the bird distinguishes hardness and softness, roughness and smoothness. Although the sense of touch (general sensation) is resident in all parts of the body, the beak, toes, and talons are of especial use in feeling and handling.

The mandibles vary in substance, form, and size. Birds of prey, as well as woodpeckers,² storks, cranes, and herons, have hard beaks, while turtledoves, house pigeons, ringdoves, and others have soft bills.

Certain birds have a curved beak; some beaks are straight, some pointed, and others blunt. Mandibles may also be thick or slender, long or short, wide or narrow, rough or smooth. Still others may even be toothed or serrated. The forms one sees are in great variety, easily found, easily examined, and readily understood in the light of the examples just given.

Swimmers that live on fish alone have a beak constructed to hold their slippery prey when caught under water. Thus pelicans have long and broad mandibles, rough on the inside above and below, the upper one provided with a hard, sharp, clawlike spike, with which they catch their fish and toss them into the pouch attached to the lower mandible that hangs there like a sack. This pouch can be opened and closed, and operates like a net into which the captured fish are directed (generally downward) by jerks of the head. Although the beak is long, it is not provided with teeth or notched above and below, so that fish could easily escape unless they fell into the pouch and were held there as if caught in a net.

The mergansers have for fishing purposes

² *pinzones*; probably from *pinso*, "I beat" or "peck."

rather long and (at the end) rounded bills; they are more curved and sharper than those of the pelican. Both mandibles are dentated, the lower one being provided, like the pelican, with a pendant pouch, which, however, is smaller than that of the latter bird. Other waterfowl that live on fish possess beaks equally well fitted for catching and holding their quarry. For example, herons have long, round, sharp bills with anterior cutting edges that are rough on the margins and dentated.

Water birds that subsist on grass have mandibles constructed for the fine grinding of their food. For that purpose they are provided inside, above and below, with indented surfaces. Waterfowl have also a tongue studded with tooth-like projections, the better to grind the herbage and enable it to be easily swallowed and digested.

In general, waterfowl and land and neutral birds that live on seeds, grain, and herbs possess bills well adapted for gathering their food and swallowing it. Some waterfowl have a wide, hollow beak, serrated on the margin, as in the case of ducks that, when their mouths are full of grain, shake their heads quickly from side to side for the purpose of ejecting sand, mud, and silt, and other objectionable matter that has been mixed with their grain, seeds, and other proper food. Land birds, like partridges and quail, that live on grain, have round, internally hollowed-out bills.

Small birds, who eat cereals, must remove the tough outer coverings of the same, to break up the kernels. For this purpose they are provided with hard beaks and, like sparrows, goldfinches, and parrots, they separate the kernels to assist digestion in their but slightly warm stomachs.

Birds with soft bills who cannot remove the hard seed coverings swallow both the hard kernels and the rest of the seeds whole. They include such species, well supplied with bodily heat, as pigeons, turtledoves, and ringdoves.

Land birds that live on meat alone have bills and claws properly provided for preparing such food but not adapted to gathering seeds. Their beaks are rough, hard, curved, and sharp like the bills of the falcons, which are also dentated, and those of sparrow hawks, which are not so deeply toothed. Land birds that eat both grains and flesh are able not only to pick up the former with their mandibles but to tear their meat into small pieces before swallowing it. This list includes ravens, crows, magpies, woodpeckers, and sparrows, whose bills are provided with sharp edges suitable for cutting flesh as well as for gathering seeds.

Neutrals have various kinds of beaks, some concave with the inner surface long and hard, the front not completely pointed but made to dig in the earth and extract roots therefrom, as seen in cranes. Neutrals that live on worms drawn from the ground have beaks formed for the purpose. Some curlews, for example, have a long, slender, hard beak, with a rounded anterior portion, while other curlews have mandibles that are long and slightly curved at the end. Woodpeckers and the like⁸ have a long straight beak. Such birds as plovers and lapwings possess a short, straight beak with the anterior segment pointed. Species whose beaks are long and slender, with the fore portion of the mandibles bent upward, live entirely in marshes and swampy ground, and their mandibles are soft.

In birds with long and delicate beaks (and this peculiarity is more or less marked) the anterior segment is usually hard, club-shaped, and thick; but internally, as well as in the center and toward the head, it is softer than in front. By means of this arrangement they feel in the earth for food without seeing it, and decide if it is edible. Those birds that

⁸ *Viticocci et picacie*. No English translation has been found for the former of these words, nor is it possible to guess its meaning.

gather grain on the ground depend upon their eyesight for food selection and have no need of soft bills to distinguish between edible and inedible matter. There are many other forms of avian bills too numerous and too tiresome to consider here.

The crests and plumes found on the head and under the throat in certain species we have already discussed. The cere, which appears above the mandibles of some birds, will be described in our account of birds of prey.

The neck supports the head. It occupies the central space between the shoulders and head, and is divided into several sections. It supports the bronchial tubes, the gullet, the veins, the arteries, the nerves, the muscles, and many vertebrae, all of them tightly bound together by ligaments. The purpose of the many vertebrae is to bolster up the head and, by means of their many articulations and ligaments, to turn it to the right, to the left, upward, outward, forward, and backward—in any direction the bird wishes. The muscles and nerves that issue from the occiput govern these movements.

Birds might be classified according to the (great) variety of their throats; one might consider whether they are long or short, thick or thin, fully feathered, bare or covered mostly with down. In every bird the extent of the neck is measured as follows: from the head to the beginning of the back; in front to the furculum ("wishbone" or sternum); right and left, to the shoulders.

Most neutral birds have long necks, as cranes and storks. Swimmers that do not entirely immerse themselves have long necks, like swans, pelicans, geese, and such non-swimmers as herons. A long beak or neck or both of these members are necessary to long-legged birds of every kind that feed on land, for they would otherwise be unable easily to pick their food off the ground; yet not all birds with a long neck have long

shanks—for example, swans, pelicans, and geese.

Land birds for the most part possess a short neck (shorter than neutrals and aquatics); but the shortest necks are found in the eagle owl, in ordinary owls, and in certain other rapacious birds.⁴ These species, however, owing to their few articulations, have stronger necks and can use them to pull with greater force.

Both male and female bustards have thick necks, the male nucha swelling up during the breeding season to induce admiration in the beholder; at other periods it retains its usual size. The reason why it remains at all times of the same size in the female others may decide.

Curlews and herons have delicate necks.

In nearly all birds the neck is clothed with feathers; but in the vultures it is bare. All birds on the wing exhibit outstretched necks except pelicans and herons, which in flight hold them drawn back and laid flat, although herons stretch them forward while flying if they are alarmed or in danger.

To the shoulders (or scapulae)⁵ are attached the wings, and between them is the neck, connected with the rest of the body. There are two scapulae, one to the right and the other to the left, placed higher than the sides of the bird. At the shoulders, as we have said, the wings articulate with the body. The shoulder girdle consists of three bones, and

⁴ The Emperor draws his conclusions about the length of an owl's neck from its external appearance. As a matter of fact the owl's neck is not so very short but appears so because most of it is concealed by a mass of feathers.

⁵ Schöppfer remarks that the Emperor correctly describes the shoulder girdle. The furcula (wishbone) corresponds to the clavicle of mammals; the second bone mentioned that extends to the sternum is the coracoid, a vestigial remainder in mammals, represented only by a process on the shoulder blade under the name *processus coracoideus*. The third bone, placed above and over the ribs, is ensiform (saber-shaped) and is called the scapula. At the junction of scapula and clavicle is the condyle, or socket for the head of the humerus.

of nerves, muscles, ligaments, and tendons. The three bones referred to are interlocked and bound together; the furcula⁶ [arises from the top of the breast and is bound to it for some distance by delicate cartilages, as well as by fine ligaments].⁷ The two furculae then branch out on either side of the neck and extend to the shoulders, girdling the throat. At the point of each shoulder they are connected by ligaments with two more bones that, in their turn, meet and are bound together at this point to form an angle. One of these bones [coracoid], of which the terminal is angular but which in the center is round, extends to the margin of the breast (sternum), to which it is joined by means of cartilages and other connections. The third bone, the scapula, extends over the back and lies against the ribs near the dorsal vertebrae. Here it is bent, broad, and thin, and has throughout no union by means of a ligament or other connection with any other bone at that part of the back.

Where these two bones are joined to the wings they are somewhat hollowed out, angular, and cartilaginous. In this hollow space [condyle] the bony head of the wing bone articulates. This last is the humerus, which physicians call the [upper] arm. It is so disposed that it can readily be moved up, down, in, or out. These, then, are the two bones that join with the furcula to form the shoulder, on which the wings are so pivoted that they can be operated from a central point, while, by the projection of the bones, each wing is held in place during shoulder movements. The shoulder does not extend higher up or lower down than is necessary, nor ever so little more in front or back than is required. It would be of little consequence to discuss here the many variations in birds' shoulders.

⁶ *furcula*, fork bone, "wishbone."

⁷ These words are taken from the Vatican Codex, fol. 22, col. 2, l. 4. They do not appear in the Bologna manuscript.

CHAPTER XXVII

OF THE WINGS OF BIRDS

Wings take the place in birds of human arms and the front legs of lower animals. They are constructed of several bones joined end to end and linked in various ways. Wings also have many joints (to insure flexibility), in addition to the necessary bones, nerves, veins, arteries, muscles, tendons, and other ligaments.

The wing bones are arranged as follows: to the bone called by the doctors the arm (*armus*), which articulates with the shoulder, are attached at its lower extremity two other bones that are called *focilia*¹ [bones of the forearm]. They present many differences in size and structure. In their middle portion they are separated and placed one above the other, but their ends are joined together. At their inferior extremities they are connected with that part of the wing that in all birds [anatomically] corresponds to the hand in mammals. This member is composed of an assemblage of small bones closely articulated and arranged in the following order: first of all are some quite small bones that articulate with the bones of the forearm and fill up the cavities in the joints but are independent of them. One of these, separated from the others, stands alone and (in birds that habitually strike with their wings) at some distance from the wing proper. It is compact, very hard, and is employed for both offense and defense. It is quite prominent in geese and swans, where it stands out from the wing. In little birds it is small, in larger ones large.

In the remaining parts one finds other isolated bones, especially one that seems to be the analogue of our [human] thumb and that is, on the outer side of its extremity, hard and sharp like a talon. Under this lies another weak and delicate bone on which the

¹ *focilia*, the *ulna* and the *radius*.

pler est. qdam enim hnt col-
lum longū. et hnti qdam pl^o
qdam min^o. alie hnt collum
curvum. et hnti qdam mag^o
curvum. qdam minus curvum.
¶ Item alie hnt collum grossū
alie gracile. et alie plumosum
alie sine plumis lanulosum

¶ Item hnti tamen curvas
Breve tamen collum habent
aues raptiores in maiori par-
te. et brevius qm aquae. et me-
die. et brevissimū oīum hnt
vulturū. et noctuaū modi. et
cerere aues rapaces. et ad hnt
collum fortius. qm cū pntētib;

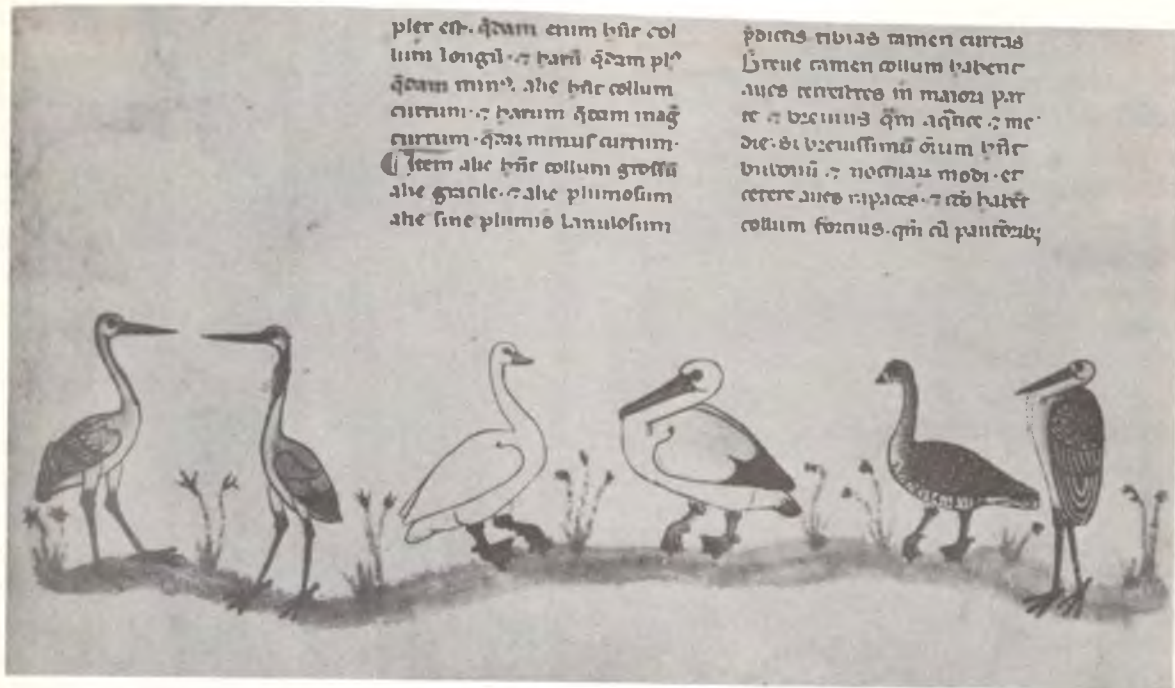

volando extendunt collum.
¶ Humeri autem seu parvae
sunt quibz coniuncte sūt. ale
et inter humeros collum desin-
dit ad reliquum corp^o. Sūt au-
tem duo humeri. unus ad dex-
teram. alius ad sinistram. et
sunt alteses lateribz. et ab ipis
incipit distinctio alarū a corp^o.
¶ Coniūtur autem et inter ossibz

preiorum ad costas. et
inter costas. et spondilia cor-
p^o. hoc autem ē curvum et latū
et debile. nullam penitus hnt
coniunctū ligamento spina-
li neqz colligatoiem. alia d^o
ossis in parte illa. ubi autem
coniuncta sunt sūt in eam hnt
duo ossa et parte ale. quodam
modo sunt coniuncta angulosa

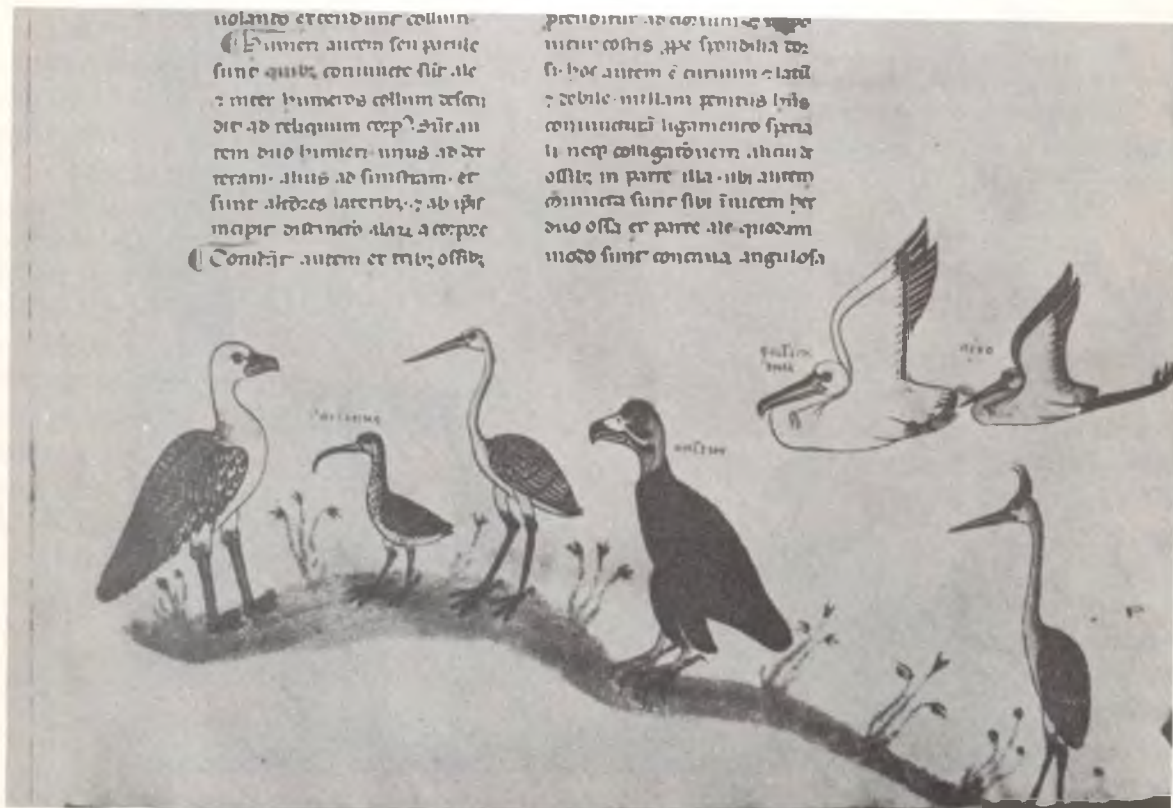

PLATE 53.—Lower portions of folios 21^v and 22, Vatican MS. Pal. Lat. 1071, with drawings to illustrate that part of the text dealing with the bird's neck and shoulders

“thumb” rests; beside this is a large bone that is fused into a single bone at the ends,² but is fenestrated and separated into two bones in its midportion. At the extremity of this are two short bones, one (the external) broader than the other and overlying it. To this wider bone the smaller (very small) bone is attached; and these are the last of the true wing bones.³

The folding of the wings takes place as follows: when they are drawn in and made to rest against the body, the upper arm descends from the shoulder and lies close along the side of the body and the ilium. The next segment, which articulates with the extremity of the upper arm at the elbow, rises alongside the upper arm; and the third portion of the wing settles down in place from the point called the *impulsorium*.⁴ This last part of the wing is called by the French *le bout*, “the tip.”

It is well that there are several joints and corresponding divisions in the wing and not merely one. In the latter case the single segment would have to be either long or short; if it were short, the wing would not be big enough to sustain the weight of the avian body, or adapted to the requirements of bird flight; and if it were long, this single joint could not readily hug the bird's body; it would project behind the tail and prevent the bird from roosting or setting, and when it was stretched forward it would project in front of the head and the wing feathers would open and not remain close together. They would not be able to fulfill their intended purpose in that situation, because the bird must move his wings in all directions—right,

left, forward or backward, up, or down—and a single articulation of the wing would not be sufficient to enable him to accomplish this. On the other hand, were alar appendages provided with more joints, bird flight would be weaker than it is. The present number of articulations fulfills all the requirements of diverse wing motions. Any member is proportionately weakened by each additional joint. Moreover, such an arrangement would interfere with the bird's ability to close the wing feathers one over the other. Were there even a fourth joint the pinions could not be properly drawn close to the body but would lie exposed and unprotected by the other wing feathers to which they would form an impediment; likewise the quill feathers (*remiges*) attached thereto would not be properly arranged and every one of the external pinions that ought to lie close to the body would stick out in an absurd fashion.

The largest of the flight feathers are those at the posterior extremity, and they have above and below them smaller cover feathers which will be described in our chapter on plumage.

The wings, whether expanded or contracted, are capable of movements in all directions at the will of the bird. These (complicated) motions are controlled by various muscles; indeed their movements—forward, backward, up, and down—are due to muscular forces operating in the desired direction. Likewise there are special muscles that provide for stretching and bending the wings. During flight the bird moves his wings both upward and downward, lifting them high over his back so that he can more effectively sweep them downward on the return stroke and thus be lifted up and driven forward.

This forceful beating of the wings is more evident in birds whose breast muscles (which control it) are thick and strong and whose flight is therefore powerful and fleet. From which one might draw the following syllo-

² The metacarpal bones of the larger and small “wing-fingers.”

³ The wing bones of birds have but three (true) “fingers,” viz., thumb and larger and smaller finger bones. The toes are as a rule four, but sometimes three. The African ostrich has only two. See Book I, chapter xxxiv, p. 74.

⁴ The wrist joint, the portion of the wing that strikes the air with the greatest force.

gism: All birds that have thick and strong muscles from the breast to the wings have strong and rapid movements of the wings. All birds that have large and firm breasts have thick and strong muscles extending from the breast to the wings. It follows, therefore, that birds with large and firm breasts are capable of strong and rapid wing movements and are powerful and swift flyers.

When in motion a wing describes an arc of a circle; all the largest flight feathers follow the same movement and describe shorter or longer arcs depending on whether they are near to or remote from the body of the bird, and these arcs are all parallel with each other. Those feathers that are farthest from the body of the bird and describe in flight the greatest arcs have the greatest power to lift and carry the bird forward. About this Aristotle says in his book on the art of raising weights that the greater the orbit, the greater the power to lift a weight.

Wings are useful in that they enable the bird to move about in search of food, to seek a better climate, and to escape danger; some birds employ them as instruments of offense and defense. Also they protect the sides and part of the back from the evil effects of cold. Many birds are recognized (classified) by the character of the wings. In proportion to their bodies birds' wings may be long, short, or of medium length. In addition to this the wing feathers of long-winged birds may be either long or short, and the pinions of short-winged birds also may vary in length. Some birds have pointed and scythe-like wings, like those of the falcon, and others have them broad and rounded. There are still other differences that might be mentioned, but what has been said will suffice for the present.⁵

⁵ For comparison, the student is recommended to read Elliott Coues' discussion of the bird's wing in his *General Ornithology*. The remarkable accuracy of the Emperor's description then becomes apparent.

CHAPTER XXVIII

OF THE DORSAL REGION

The dorsum (back) stretches from the lower extremity of the neck to the hips over the space between the wings and the sides. It is bony; in the center are vertebrae, including all those between the cervical and the beginning of the lumbar region.

Closely affixed to each side of the dorsal column are the ribs, forming with their corresponding dorsal vertebrae an encircling arch. The chief function of the back is to protect that region of the body. The dorsum varies in species; in some it is broad, in some narrow, in some long, and in others short.

CHAPTER XXIX

OF THE HIPS

The hips reach from the end of the bird's back, right and left, to the tail. At their middle runs the vertebral column, extending from the termination of the dorsum to the tail. On either side one finds broad downward-curving bones called ilia, with a hollow in the center of each, the acetabulum. These serve to guard the kidneys from damage from without and to protect the vertebral column through the widening of the ilium.

CHAPTER XXX

OF THE TAIL

The tail of the bird lies over the anus, whence it spreads outward. It covers the lowest vertebrae of the spinal cord, expanded to allow insertion of rather large feathers. We shall speak further about the tail when considering the bird's plumage.

Birds' tails are not always in proportion to their bodies. Large birds may have short tails and small birds long caudal appendages.

CHAPTER XXXI

OF THE OIL GLAND (*PERUNCTUM*)

This is a peculiar structure which lies above the tail. It consists of a double gland in the center of which (toward its end) rises a compact, stout elevation resembling a brush.¹ This gland receives fluid oil from the body, which the bird squeezes out with its mandibles, collects, and then conveys to both feathers and talons, in consequence of which they are able better to resist moisture. Rain affects the oiled parts very little but runs off them completely and swiftly. Feathers and claws are thus preserved in good condition. Talons of birds of prey, owing to the noxious character of this oil, inflict more deadly injuries upon and bring about quicker death of their quarry because the wounds they make are toxic.²

Birds differ in the amount of glandular secretion produced. Aquatic species as a rule have a larger gland and oil in greater profusion than either neutral or terrestrial birds.

CHAPTER XXXII

OF THE BREAST OR THORAX

The breast (breastbone or sternum) in birds is that member at whose center lies the heart, which is protected by it. The sternum

¹ Elliot Coues (*General Ornithology*, p. 129) says: "the uropygium or uropygial gland is a two-lobed or heart-shaped structure at the root of the tail, composed of numerous slender tubes or follicles (that secrete a greasy fluid) the ducts of which unite to form larger tubes that finally open through one or more pores upon a little nipple-like elevation." How closely the thirteenth-century author approximates the nineteenth!

² Schöpffer calls this last statement a fable; if it were true, the beak also would be poisoned. According to Coues the occurrence of oil glands in birds varies; they are always found in waterfowl, but are only slightly developed in some land birds and are entirely absent in other species.

is convex carinate, i.e., is raised in the middle of its length; but internally it is hollowed out. The sternum is bony, and, though thin, it is strong. It has a raised partition along its center line below which, to right and left, lie the true breastbones. The upper portion of the sternum is thick and is closely attached to the furcula and shoulder bones [coracoids]. The lower portion overlies the ovarian region; it is softer and more cartilaginous and is separated into several bony parts that are joined to the sides of the body.

The muscles that move the wings arise from the breastbones and are carried forward to join other muscles that spring from the angle formed by the two lateral surfaces of the sternum and the keel.

There is also a nerve that lies stretched out along the central line; it supplies the muscles on both sides of the thorax. The sternum serves several purposes: its middle is elevated to guard against external injuries, and it separates the muscles supplied to each wing so that one set may be used without simultaneous movement of the other.

The hollow in the sternum also serves for the attachment of muscles; the expanded nerve in the center of the sternal shield connects and intertwines with the muscles. The concavity in the breastbone also receives the heart. The abdominal portion is relatively soft; were it hard it might injure the delicate contents of the belly. Indeed, for this reason, in many birds, so-called posterior extensions of the breast are joined by connective tissues only, especially in the region of the bowels.

The thorax varies in different birds; waterfowl, especially swimmers, have a long thorax—indeed a longer body—than land birds. In some species of falcons the margins of the sternum are more everted and thicker than in hawks and sparrow hawks (*accipitrum et nisorum*).

The sternal keel in cranes is remarkably developed; it has on its internal aspect a hol-

low channel¹ in which the trachea lies and winds. Its remaining portion, that appears to be solid, has no real solidity and is of slight weight. It is of a spongy consistency and light to carry. One does not find this condition in the breastbone of other birds.

The sternal bones of large birds are, in proportion to their size, less compact and less bound down. If they were dense they would be very heavy and a burden to carry. In small birds the firmness and solidity of the bones are of more importance than their compactness, because rapid movements are more frequent with them than in large birds and they would be in danger of breaking more fragile parts.

CHAPTER XXXIII

OF THE SIDES OR FLANKS OF BIRDS

The sides of the bird lie between the breast and the back; they stretch from the armpit (axilla) to the crest of the ilium. They include the ribs (which articulate with the dorsal vertebrae and are more or less numerous in birds), as well as the coverings and muscles attached to the ribs themselves. The chief function of the flanks is to guard the heart, lungs, membranes, and other parts that they surround, in the same manner that the heart is protected in its anterior aspect by the breastbone. The abdomen, called by some the ovaries, encloses the parts that lie between the lower border of the sternum, the ilium, and the hips, as far as the anus. A large portion of the belly extends also under the sternum as far as the heart, and contains the stomach, intestines, liver, spleen, and other digestive organs. The upper part of the belly is membranous, and provided with nerves and muscles. It is so soft and elastic that all expelled matter, such as eggs, fluids, and flatu-

¹ This is seen also in swans. Cf. Book I, chapter xxxvii, p. 78.

lence, can be passed along the gut. The purpose of the abdominal coverings is to protect the parts mentioned and to keep them warm and to allow the expulsion of extraneous material.

It has already been noted that in the lumbar regions there are two iliac bones that are long, concave, and broad at their lower extremities. In the middle of each of these bones one finds a cavity which physicians call the acetabulum,¹ into which fits the upper joint of the hip.

Here we may mention the hips, legs, and feet as the members which hold the body erect on the ground and assist the bird to wander over the earth and, incidentally, to take care of its own body. In addition, the feet and claws enable the animal to scratch where it itches and to dig in the earth, as the bird pleases.

Hips, legs, and feet are constructed of many bones ingeniously arranged. The femur, which forms the upper segment of the leg, rests in the acetabulum and is held in place by nerves, ligaments, and other tissues. It has numerous muscles that co-operate to move it in various directions, and it is correlated with the upper arm (brachial) bone of the wing. In some birds it contains marrow, in others none. Next in order come the tibia and fibula, two bones of the lower limb that may properly be said to correspond with the *focilia* of the wing. There are two, so that should one be disabled the other would function in its stead.

Externally and outside the fleshy parts lies the tibia, the stronger and more compact of the two bones, adjusted to meet any blow. The other (fibula) is more delicate and placed so far inside that it might easily be mistaken for a nerve. The lower it extends the rounder and thinner it becomes. These two bones (*focilia*) that compose the osseous portion of the

¹ Frederick's term is *scia*—from the same root as "sciatica."

lower limb (*crus*) are called by some the *coxa*, and that part of the leg above them (the upper leg) is termed the *supra coxam*. Some persons call the bone of the lower limb that reaches to the toes the shinbone (tibia or *crus*); but we believe that this bone belongs more properly to the foot,² as is plainly shown in pheasants, cranes, and bustards. This bone (which articulates with the toes) is in some birds covered with scales and is devoid of feathers; in others the scales are absent but it is completely feathered to the toes; in still others the feathers extend as far as the talons, while many exhibit sparsely scattered feathers set between scales, as seen in some falcons.

Certain birds are armed (in the posterior part of the legs) with a sharp, long process called a spur. We find them in pheasants, fowls, and peacocks, but in no other genera.

To the extremity of the metatarsus are closely bound by means of interwoven ligaments and sinews the toes of the foot, which will be fully described in the chapter on that subject.

When one draws a comparison between legs and wings, the following facts appear: those birds with large and fleshy breasts have strong wings but weak lower limbs and shinbones and are consequently stronger in flight than in walking; conversely, those birds that possess long, well-built legs and shinbones have a less-developed breast and in consequence are better walkers than fliers.

As portions of the lower limbs are concealed by the flesh, they seem smaller than they are in comparison with the corresponding parts of the wing.

The articulation of hips, legs, and feet is in the direction opposite to that of the wings (outward and backward against the body), as is quite evident when examples are investigated. The joint between the femur and the tibia in birds bends in the direction opposite to the corresponding joint in the hind leg of

pedestrian animals, that is, forward and not backward, so that their motions in standing and stretching forward may be more easily accomplished. In other words, when a bird wishes to grasp with its talons an object in front of it, it can readily accomplish this act. It could not do this from behind; but it may extend or stretch its feet forward, backward, left or right, to suit its purpose.

In swimming birds the femur, tibia, and feet show more rapid development than the wings. They must go in search of their food in the water by means of their feet, not with their wings; and their chief defense in the water is by swimming and diving, in which acts the feet have more important functions than the wings. For this reason Nature has provided an early and more complete development of the former than of the large flight feathers of the wing. There is another reason: exercise in swimming impels an abundance of nutritive juices to these organs. The wings, which are very little in motion and are not needed for retreat (from danger), are of slow development in contrast to the legs and feet.

In birds that do not swim to any extent, conditions are different; their upper limbs are developed early, for they must be used in providing food, in escaping danger, and for purposes of defense.

CHAPTER XXXIV

OF THE TOES AND FEET

In birds the tibia and leg and, in consequence, the whole body, rest on the toes as on a base. For this purpose we find that they are several in number, spread out, and separated from one another, so as to form a broad and steady support. They are intended also for clinging to branches and other objects upon which they perch, and for many other purposes. Their bony structures are held in apposition to one another by ligaments and

² Metatarsus.

fasciae, and in the same way they are bound to the bones above them in one firm union.

Many birds have four, some three, others only two toes.¹ The majority of the numerous birds with four toes have three in front and one behind; only a few have two in front and two behind, like the woodpecker, the parrot, and others that cling to the trunks of trees. In birds with three digits the hind toe is missing altogether, so that they have their toes only in front, like the bustard, snipe, plover, and those birds that frequent mostly stony fields or the rocky beds of streams. The ostrich, with only two toes, has one placed centrally on the foot and the other outside, with no inner toe to interfere with walking; and both of them are directed forward. Although the ostrich is a huge bird, its scant supply of toes has few tasks to perform; its feet are not needed for roosting on branches but only for walking.

In some birds the toes are joined by a thick skin, as in the pelican² and the goose. This is a tough, cartilaginous membrane binding the toes in one sheet, although they are kept separate from one another, like the toes of swimming birds that are so arranged that the back stroke of the foot is made against the largest possible mass of water and drives the body of the bird forward most effectively. The wider the connecting membrane the better the bird swims. Other birds have toes with membranous attachments, but these are only divided lobes, as seen in the coot. The pelican is the only palmated bird that has the hind toe joined with a tough fascia to the inner one; this hind toe is placed at a considerable distance from the exterior front toe.³ Any-

¹ Of the birds known to the Emperor, bustards, thick-knees, and plovers have only three toes, and the African ostrich only two, one of which has no nail.

² Cf. Book I, chapter ii, p. 8.

³ A number of other birds have four toes joined in the same fashion—for example, cormorants, the snake darter (*Plotus*), the tropic bird, the gannet, and the frigate bird.

thing resembling this condition is never seen in other web-footed birds where the posterior toe is not attached to the anterior digits. The toes of all other birds are entirely free of such membranes, and such species are called *non-coriales*.⁴ To this class belong land and neutral birds.

The toes are not straight, rigid, and unprovided with joints, for then they would be less adapted to their uses. If they could not be bent in a circle (having no joints), they would touch in only one place those objects upon which birds roost—branches, clods of earth, rocks, and other bodies—chiefly round objects. As is stated in geometry, the tangent to a circle must touch it at a single point, making the least possible contact. Hence several joints are essential in the toes of the bird's foot, for they permit it to bend in a circle and allow contact at a number of points with the object grasped, so to hold it more firmly. This is all the more desirable in birds, since they rest chiefly on one foot only when sleeping.

It is not necessary for the joints of the avian toe to bend upward, but a downward flexibility is essential in order that the bird may grasp⁵ the branch on which it usually retires to sleep. This is true especially in birds without webbed feet who nest only in trees; in order that they may hold more firmly and securely to their perches the anterior digits are formed with a number of joints.

The number and position of the toe joints, especially in those four-toed birds that have three digits in front and one behind, are as follows: The hind toe has only one bone and a single joint and for that reason is stronger; for it has been discovered that many jointed members are less rigid and therefore weaker than those of few joints like the hind toe of birds. This arrangement is useful when the bird supports itself on a single hind toe as

⁴ Nonpalmates. This last sentence is omitted in the Vatican text, fol. 27, l. 32.

⁵ *brancarent*; It. *brancare*, "to handle," "to feel."

much as it does on its three front digits. The former acts like the thumb of the human hand. The front toes are so bent toward the hind toe that they form a firmly closed circle about any object they may grasp. In this way the strength of the one is equal to and opposed to that of the other three. Also falcons tear their prey to pieces with the hind toe—which the falconer calls a talon or claw.

The inner (fore)toe in four-toed species has only two bones and two articulations. The latter are stronger than in the other two anterior digits, as the bird must grasp objects with greater force as well as support and defend itself effectively therewith. The bird steadies itself upon this toe, which makes (in contracting) a more perfect circle with the hind toe than with the other digits.

The middle toe is much longer than the others. It has three bones and three articulations and is devised for making a wider circle so that it may grasp a greater circumference than the other anterior digits.

The outer toe has four bones articulating at four joints. It is shorter than the middle toe because its four bones are together shorter than the sum of the other three. Since it is constructed with more joints, it is weaker than the rest; but it has no need of great strength, since the bird does not rely upon it for defense or for support; its function is chiefly to seize an object on the outer side (thus putting in place the keystone of the arch), as well as to grasp small round bodies by means of its numerous joints.

Pythagoras calls the number of the articulations (of the toes) perfect; i.e., the hind toe (the talon) has but one joint, the inner foretoe (which some people call the thumb) has two, making three in these two digits. The middle toe has three joints and this completes the *senarius*.⁶ The outer foretoe has four articulations, which, added to the previous total, makes ten, the total ideal number, all placed

⁶ That which contains the number six.

in the order mentioned and functioning exactly as needed. Thus in the joints of the foot is revealed the wonderful order of the works of Nature.

It is further to be noted that the whole foot and the toes are covered with a skin continuous with, but quite different from and tougher than, that on the remainder of the body. This protective covering is in some instances scaly, sometimes feathered, in other cases free from feathers—all these provisions intended to protect the feet and legs, either in the water or on land, from thorns, stones, and other objects likely to wound them.

CHAPTER XXXV

OF AVIAN CLAWS AND TALONS

The talons have been described by some physicians as homogeneous or consimilar (*consimilia membra*) organs; but we prefer to place them among the functioning organs (*officilia membra*), since they are attached to the toes (which are functional) and have themselves many tasks to perform. They are composed of a compact, horny substance, and are hollow in their interiors, into which are inserted the ends of the toes. They are also connected with the fleshy parts and the overlying skin; their fasciae are tendonous and carry nerves, arteries, and veins that bring nutritive supplies. At the end of each toe is a nail, one purpose of which is to protect the fleshy terminal of that member from injury by hard objects; another is its use as an instrument for scratching and for digging in the earth. In many birds it serves as a weapon of offense and defense—to fight, rob, and lacerate and to cling to other animals.

Some birds have straight claws, as in the nonraptorial species; others, as in birds of prey, have curved and hooked talons. There are also some harmless birds with crooked claws, e.g., jackdaws, magpies, and others that

Aristotle in his book on animals classes with raptorial birds because of that peculiarity.

As a rule, birds have a nail on the middle digit, serrated on its inner aspect.¹ The other nails are not so provided; hence, in scratching the head and other parts of their bodies that are within reach, and in digging, birds mostly use the middle toe of either foot. Larks, crested larks,² and wood larks³ have on the hind toe a remarkable, straighter, and longer nail than on the other toes or than that found in other birds.

Cranes have on the inner front toe, for defending themselves, a stout, hard, curved, and sharp nail (resembling that of the raptorial birds) that is not found on the other toes. Nature has so arranged it that while cranes are standing on their feet these armed talons lie sideways and not with the tip pressed down, so that it will not be dulled or injured. The claws of the stork⁴ are not like those of other birds but are broad and resemble the nails of men and apes.⁵

CHAPTER XXXVI

THE INTERNAL ORGANS OF THE BIRD

The internal avian functioning organs are mainly muscles, the skull, the meninges, the brain itself, the vertebral canal, and such other parts as are not directly connected with

¹ *parte domestica*.

² *cozardi*; the form *cotardus* also occurs. The species is not yet identified with certainty. Schneider comes to no definite conclusion about it, while in his carefully prepared and resourceful dictionary Du Cange gives only *aviculae species apud Fredericum II*. Schneider ventures the guess that the bird is the crested lark, and we so translate it. Cf. chapter xxiii-1, p. 59.

³ *Melanocorypha calandra*.

⁴ Schöpffer says that the stork, like all pygopods, has flat talons provided with the usual nails; but a close examination of the bird skin proves that the Emperor is correct!

⁵ This reading is taken from the Vatican text. The Bologna MS., fol. 25, col. 1, says: *sicut homines et firmantur*.

the senses (*quae sensui non subjacent*) which we shall enumerate and discuss completely only when they are definitely present and offer some pronounced variation.

The muscles, which consist of flesh traversed with nerves, ligaments, fasciae, and other membranes, serve to move the limbs of all species, and they vary considerably, since they must move not only different limbs but the same limb in different directions.

It is evident that the skull protects the brain, and its conformation depends upon the species of bird to which it is assigned, for its shape follows that of the head.

In birds there is no apparent variation in the manner in which the brain activates the spinal column and the motor and sensory nerves that carry impulses to all parts of the body. There may, however, be some differences in the ventricles.

The spinal column (composed of vertebrae bound together in one body) protects the medulla and extends to the termination of and includes the caudal vertebrae. It is to be mentioned here that it is longest in certain birds that have a long neck and rump and shorter in others. The number of vertebrae also may vary.

The dorsal vertebrae are so intimately bound together until they reach the neighborhood of the lumbar region that they appear to form one structure. Here at the site of the iliac bone the dorsal vertebrae stand out distinctly. From the lumbar region over the kidneys down to the beginning of the tail (above the anus) the vertebrae are flattened and their course lies between the two hip bones (*os coxa*). This passage is more marked in some birds than in others, the part being called the croup (*crupper* or *crupponus*). Here the attachments are more intimate, and the openings in the bone better defined. Where the anal bones (*ossa ani*) end and the tail begins, the caudal vertebrae are slender. After a short distance these tail joints become

stronger and broader, owing to the addition of large muscles serving the double purpose of the better support of the oil glands and of furnishing added space for the growth and use of the large tail feathers. Toward its termination the vertebrae again become slender.

The spinal marrow¹ does not call for further comment in this place. It may be noted, however, that it emerges from the brain, passes through the channel in the vertebrae to the lowest caudal appendage, thickening over the region of the kidneys, where this conduit is widest. From the medulla, pairs of nerves emerge, so that in every instance there is a pair between each two vertebrae, one on the right, the other on the left side.

We have now to discuss the fauces and the tongue, wherein birds differ greatly. The former is large or small according to the structure of the body; in some birds it is dentated below the palate, in others not. Birds have neither uvula, epiglottis, nor teeth, the place of the last being taken by the mandibles.

The mandibles surround in some birds only a small tongue, or the latter may be absent altogether,² as in the storks, pelicans, and other birds that have a curved, spoon-shaped bill and, in consequence, a monotonous call note because their principal instrument of sound is lacking. Birds with a tongue may have a good voice as well as a wide range of notes, especially if the organ is freely movable. A thin, flexible tongue associated with a small, delicate bill may produce a very fine song and varied notes, as in the nightingale, skylark, calandra lark, starling, blackbird, goldfinch, and other songsters that warble not only their own melodies but imitate wonderfully the songs of other birds. Some of these carol more in the spring, during the pairing season, in sunny, calm, warm weather

¹ *nucha quae dicitur medulla spinalis.*

² The pelican and its near relatives, as well as the ostrich, ibis, and goatsucker have such small tongues that they may easily escape observation.

and at dawn, while others sing both day and night during the spring months—like the nightingales—but are silent at other seasons of the year.

Birds with a thick and fleshy tongue³ endeavor to imitate the human voice and words they hear most frequently. These are chiefly the raven, the magpie family, and, still more frequently, the parrots of the green variety and even more often those of the white species. Parrots also pronounce the letter "R" better than other birds. Vocal accomplishments are due to the form of the tongue and other portions of the vocal organs (syrinx).⁴ The larger birds have few notes because their vocal equipment is deficient; but all have at least three calls, one when they are hungry, another when they wish to copulate (the male having then a peculiar call and the female a reply), and a third incited by fear.

The lower surface of the tongue presents in some birds a hard, sharp growth that extends to the anterior end, where it becomes still harder and firmer. A medial transverse portion is rather flexible, and under it is attached a bone (the hyoid). Internally it divides the tongue into two parts that spread on either side to the back of the head and appear to be well supplied with nerves.

The form of the tongue follows in many birds the shape of the mandibles, the container thus determining the form (or mold) of the contents. Hence in a straight beak the tongue is also straight, in curved bills curved, in narrow and delicate bills narrow and delicate, in broad bills broad, in dentated bills dentated

³ This rule applies only to parrots, since other birds that imitate the human voice and speech, such as ravens, jackdaws, magpies, starlings, and jays, do not have thick, fleshy tongues.

⁴ In a few birds, such as the ostrich and vultures, there is only an indication of the syrinx, while in singing birds it is a remarkably well-developed and wonderful musical box (at its junction with the bronchial tubes) worked by many muscles too complicated and varied to describe here.

(serving to cut grass), in short bills short, and in hard and pointed bills correspondingly hard and pointed, as in the woodpeckers that use the beak to peck and bore holes in trees, and the apex of whose tongue is provided with a sharp point for impaling and pulling out worms to eat.

It is evident from the foregoing that the tongue of the bird varies in character like its mandibles. Another function of the tongue is to assist the organ of taste.⁵

At the base of the tongue there is an opening which extends to the trachea. This latter is not provided with an epiglottis but automatically closes when food and drink pass over it on their way to the posterior opening, the entrance to the esophagus.

In the roof of the mouth, that is, in the palate, will be found two openings: one, in front, is connected with the nasal canals and conveys inhaled air to the trachea; through the other, at the posterior space of the palate, waste excretions from the head are discharged. There also are the parts that take the place of the (absent) uvula.

CHAPTER XXXVII

OF THE TRACHEA AND BRONCHIAL TUBES

The trachea is a cartilaginous, annular organ. Until it reaches the lungs it consists of but one tube; at the pulmonary region it divides into two smaller branches that are supplied (each) to a lung. In its course from the larynx to the lungs it passes, as a rule, directly over the vertebral column; but in cranes there is a remarkable departure from this arrangement. In these birds the trachea stretches long and straight along the furculum, then goes on and folds back between the bones of the sternum, as between two

⁵ It may do so in birds with soft tongues, like swans and ducks.

plates; after a double loop it divides into two tubes that are separated into the corresponding lungs, as in other birds. This anatomical plan¹ accounts for the deep, bell-like call note in cranes, who with a loud voice make use of both inhaled and exhaled air from their lungs to the best advantage.² Young cranes have in their first year a sibilant voice.

CHAPTER XXXVIII

OF THE LUNGS

The lungs of birds are divided into right and left lobes, that are in close apposition to the ribs and extend over the vertebral column. They reach on both sides to the last of the ribs.

CHAPTER XXXIX

OF THE DIAPHRAGM

This muscle is not well marked in birds; it lies between the breathing and the digestive apparatus. In addition to the cardiac cavity, there are several membranes that separate the various nutritional organs, for instance the liver from the intestines and, similarly, the remaining viscera from each other.

CHAPTER XL

OF THE ESOPHAGUS

The esophagus extends downward from the upper part of the throat. In certain birds—swans, for example—it appears to surround the latter; in others it enlarges, just after the furculum is reached, into a large sac called

¹ Resembling that of a trombone.

² Other birds have tracheal and bronchial tubes resembling those of the cranes, the whistling swan (*Cygnus musicus*), for example. Coiled bronchial tubes are also found in ducks, fowls, and penelopes (*guans*). Cf. also Book III, chapter xxiv, p. 261.

crop (*gorgia*). Into this receptacle the food and drink are first received, to be warmed up and prepared for the stomach. Some birds have in this situation no enlargements of the esophagus, in fact no crop at all, between throat and stomach;¹ however, where it joins the stomach it is somewhat enlarged.

CHAPTER XLI

CONCERNING THE STOMACH

The stomach is the organ to which (by means of the esophagus) food and drink are conveyed. It extends downward to the intestines. In some birds the stomach is very fleshy, thick, and compact, as in ducks, geese, and fowls, in others, birds of prey for example, it is more tendonous (or sinewy) and consists mostly of an inner and an outer coat. Food and drink are conducted from the mouth through the esophagus to the stomach. After digestion, the waste matter is carried from the stomach to the intestines. The latter form numerous convolutions and extend as far as the anus, situated beneath the tail.

CHAPTER XLII

OF THE LIVER

The liver is a blood-making organ, divided into two segments, a right and a left lobe. Attached to the liver of some birds one finds a gall bladder, which is absent in other birds—pigeons and turtledoves, for example.

CHAPTER XLIII

OF THE KIDNEYS²

Birds have two kidneys, one on the right, one on the left side. They lie close to the

¹ H. Siedemann says it is well developed only in climbers (*scansores*), swamp, and water birds.

² Aristotle denies that birds possess these organs.

vertebrae under the iliac bones and extend toward the anus. The urine is excreted from the kidneys by way of the anus through the uriniferous tubules, which pass below and in close contact with them. As the urine is passed with the feces, the bird does not require and does not, indeed, possess a urinary bladder.

CHAPTER XLIV

OF THE TESTES AND THE OVARIES¹

At the root of the kidneys, in the male bird, there project over the vertebrae two testes, one on the right, one on the left. In the female are the organs in which eggs are created, which in consequence may be called the matrices (ovaries). These sexual organs exhibit but little variation.²

CHAPTER XLV

OF THE PLUMAGE OF BIRDS IN GENERAL

The plumage is an appendage of the avian body, the analogue of hair in mammals and the scales of reptiles, necessary to their well-being as a cover for the skin, to protect them against heat, cold, and wet, and to support them in the air during flight. The bird's plumage is frequently present at birth, but when first out of the egg this covering, while neither hair nor wool, has some of the char-

¹ Chapters xliii and xliv are all too short. It must be added to this chapter that it is only the left ovary of the avian female that functions (important to remember in sterilizing domestic and other birds). The right Fallopian tube is, as a rule, more plainly seen than that on the left. Whether it acts as a substitute bladder or as a canal, its reproductive functions are certainly as negligible as that of the right ovary.

² During the pairing season the testes are greatly enlarged, although in undeveloped young birds they are barely visible. This is important for collectors to keep in mind while determining the sex of a bird. One must not mistake the suprarenal gland, that lies close to them, for the male testes—a common error.

acteristics of both and protects the young from the cold.

Next appears what is called by some people wool and by others down. These feathers are delicate and soft, though longer and thicker than the first covering and afford better protection. When these appear the first covering is moulted. Third, there are the plumae and, finally, the flight feathers.¹ Plumae in general have a hollow barrel (or quill) and a shaft (rhachis) rising from a small hump, or thickening of the barrel and extending to the end of the plume. These true feathers cover the entire body. The flight feathers have a larger barrel and a shaft that extends between the vanes to the tip of the feather. They are also much larger than the plumae and are intended more to sustain the bird in the air than to provide a protective covering; they are found only on the tail and wings.

As both plumae and flight feathers develop and outgrow (in length) the down feathers, the latter drop out, and the larger the former become the more quickly the down is shed. As this leaves an unprotected space between the barrels of plumae and flight feathers, a second growth of down appears, finer than that previously lost. This helps to conserve the heat of the body and is shed only in moulting. For the same purpose certain birds have a secondary shaft (or aftershaft) developed at the base of their contour feathers which carry also on their lower portion a soft downy growth in place of the usual bar- bules. Others do not have the aforesaid after- shaft but have proportionately more of this down growing on either side of the shaft and closer to the skin. This enables the feather to fulfill its function of protecting the bird from the cold and wet.

Feathers grow in such a way that between the barrels of two adjoining feathers there is a third one that, like the scales on a reptile,

¹ Both these types of feathers are included (in modern classification) under the term "contour feathers."

overlaps them and completely covers the underlying parts. The second series of feathers is in turn protected in a similar fashion.

CHAPTER XLVI

OF THE COLORS OF AVIAN PLUMAGE

Except in the case of birds of prey used in falconry (to which we shall give particular attention) we shall not discuss in detail the subject of color in birds' plumage because of the innumerable combinations it displays. For example, a whole series of birds may be more or less white, black, gray, yellow, earth-colored, blue, or plainly dappled (piebald or checked) in black and white on different, or the same, feathers; they may also be green or saffron yellow. Even in the same species one finds examples of variation in color, either of the whole bird or of single feathers. There are also birds whose plumage changes color with age, like those swans that in their first year are gray, in the second gray and white, and in the third year entirely white. This is true of many other species. It is also noticeable that some birds at the mating season assume a different-colored plumage, just as many of their organs undergo a change of size or form. This is the case with the gray heron, the down¹ and flight feathers of whose wedding plumage shed a dusty gray pollen that stains a cloth with its color. The beak and feet of this species become red at breeding time and during the moulting season, when the plumage also alters its coloration. Because of all this, we shall not attempt a general consideration of color in birds' feathers but shall discuss now only the rapid or slow growth of (plumular) down and flight feathers.

In land birds that nest on the ground and to whose young the parents bring no food (be-

¹ *pluviplumes.*

cause they are able to get it themselves immediately after birth) the growth of feathers is most rapid and soonest completed. In a less degree does plumage growth advance when the birds are hatched on the ground but are fed by the parents. Even then feather development is more marked than when nests are built high up off the earth where it is not possible for the fledglings to come down to secure for themselves their proper food. Nature has with foresight provided that birds born in nests built on the ground are as early as possible provided with protective plumae and other feathers, because they are exposed to dangers from enemy snakes, worms, rapacious animals, and birds of prey. With a covering of feathers they can ward off danger, follow their parents in search of sustenance, and are even seen—in the case of the young partridge, pheasants, quail, and bustards—to fly early after their parents. There are also some birds that are hatched on the ground and yet fed by the parents, like the larks and crested larks, that learn to fly sooner than others that nest on bushes, trees, cliffs, and other high places, and are not exposed to the same dangers, and whose plumage is of slower growth.

The young of rapacious birds are not subject to such dangers because the nest (eyrie) is more safely lodged on a cliff or in a lofty tree to which the old birds carry food from a distance; hence their feathers develop and grow slowly. This is probably due also to the fact that Nature has not provided them with the amount of adipose tissue that other birds possess. We notice this in those portions of the avian body where there is least fat—in the wings, for example, where flight feathers are of slow development. Finally, birds of prey have in comparison to their body longer contour feathers than other birds, and this adds to the time required for them to acquire full development. Their fledglings are early driven out of the nest by the parent birds,

that they may take exercise and learn the use of their wings for securing food and avoiding danger. At the same time there is a gradual increase in the strength and attachment of their flight and cover feathers, while in the young of nonrapacious (harmless) birds these feathers are less developed in relation to the length and size of the body.

It is in the nestlings of aquatic birds that all the feathers develop latest; for, although the parents do not supply food to them, they do protect the young from threatened danger with their own bodies while in the water where they find their food. They have no need, therefore, for feathers as soon as they emerge from the egg. Although the plumage of waterfowl is the latest among birds to develop, it grows the fastest of them all—a fact to be attributed to their unusual supply of fat and to their watery surroundings. We notice this peculiarity in geese, ducks, and other swimmers that gain their food by the mandibles only (using their legs and feet to propel the body), long before feathers grow on them, or before their wings have developed sufficiently to lessen the dangers that threaten them. If the feathers and pinions of such birds are shed, they are replaced in a very short time by a complete new growth.

CHAPTER XLVII

OF THE CONTOUR FEATHERS

The smaller contour feathers appear and are fully established before the flight feathers. They act as a covering and protection against the weather. Those feathers that grow in the fatty regions of the body and nearer the heart than the flight feathers, and that are shorter than they, attain full growth the soonest. They develop more rapidly than other plumae that are in portions of the body having less fat (where they receive less nourishment), and they attain their full size sooner

than the larger feathers that reach full growth more slowly. This phenomenon is also seen in the flight feathers (primaries), that grow farthest from the body of the bird and the barrels of which lie on the pinion;¹ they develop more slowly than other flight feathers that grow closer to the body proper. Consequently it may be claimed that for this reason the feathers called the *vani*² develop more quickly than the (ten) primaries just mentioned.

Among the tail feathers (rectrices) there are some that develop in a shorter time than the wing feathers; there are, also, two quills in the center of the tail (under which the rest are folded) that are nourished by the fatty matter of the oil glands (*uropygium*). These two middle feathers grow longer and stronger than the others because they freely draw their fatty substance from the very center of the oil gland. The farther the insertions of the remaining feathers of the tail are from the gland, the slower their development.

We must now pass to the discussion of bird down and its distribution over the avian body, and also discuss the number of feathers in the bird's wing and tail.

CHAPTER XLVIII

OF THE DOWN

Avian wool or down has a luxuriant growth about the anus and in the ovarian region of the abdomen, since these are the locations of the viscera, which have mostly a dermal covering and no fleshy protection, although they require to be kept warm. It is true that one finds much down on the breast, but not in such

¹ The wrist, hand, and finger bones.

² Secondaries, which vary from six to forty in number.

abundance as below (on the abdomen). But the fatty state of the breast alone is not sufficient to protect it from the rain and wind. The sides of the body have less down, but they are guarded by the closed wings. The down on the back is very thin, but the force of the wind is not felt here. The contour feathers (*plumae*) on the back, on the loins, and down to the tail are, for the purposes mentioned, firmer and stronger (though not more numerous) than those on the breast or in the ovarian region, where their growth is especially thick. On the sides the *plumae* are few in number, as the protection afforded by the wings amply supplies their place.

In the description already given it was noted that feathers are not found on the throat and head of every bird; also that in some species they are entirely absent from certain parts of the whole body. In some birds feathers extend over the upper and lower coxal joints, in others even down to the toes, indeed, as far as the talons, where feathery traces are sometimes found. Examples are the eagle owls and short-eared owls, and other birds in whom it is of great advantage when they fly through thorny thickets in pursuit of their prey. In the eagle owl this protective covering is more like ordinary feathers, but in the case of short-eared owls it more closely resembles hair.¹

Birds with a tough, scaly, and leathery covering on their feet have no down feathers, because the scales prevent their development. In a few instances, however, one notices on the skins and talons of falcons, hawks, and sparrow hawks a few feathers between the scales.²

¹ Schneider thinks "*noctua*" best rendered by "barn owl." The original manuscript says, *in generibus bubonum et noctuarum*. The various characteristics mentioned lead us, however, to believe Frederick is speaking of the eared owls (*Asio*).

² A doubtful statement.

CHAPTER XLIX OF THE WING FEATHERS

Flight feathers grow only on avian wings and tail, their function being to raise and support the body of the bird in the air. These feathers in the outstretched wing and tail unfold like a fan.

Air and wind support the bird while aloft, but progress through space is accomplished by flying in practically the same manner as beasts walk along the ground and fishes swim in the water.

We shall consider now the number, position, and characters of the flight feathers in the wing and of the quills in the tail. Since some of the nonraptorial species are found with a variable number of both flight and caudal feathers, no definite number of these can be stated in each instance, as the tails of domestic fowl, pheasants, peacocks, ducks, and other birds demonstrate. We shall for the moment pass over these and describe the wings of birds of prey used in falconry,¹ a subject that is obviously of great concern to us. In rapacious birds the number of feathers in the tail is more constant, though their form may vary. What we shall say concerning the feathers of birds of prey and particularly their location and use may be considered, on the whole, to apply also to nonrapacious species.

CHAPTER L OF THE NUMBER OF FLIGHT FEATHERS IN THE WING

In every bird's wing^{1a} there are twenty-six flight feathers: four called tertiaries² close to the body; then twelve smaller, rudder feathers (secondaries),³ stronger and stiffer than the four preceding and with a different color

¹ In the following chapter.

^{1a} Frederick II is speaking here of birds of prey.

² The *remiges*, which the Emperor calls *corales*.

³ These the Emperor speaks of as *vani*.

and form; finally, ten additional rudder quills (primaries),⁴ still stiffer, longer, and more compact than the secondaries.

The most external of these ten is called the swing feather (*saxellus*). This feather and those just preceding it are shaped and fashioned like knives. The noticeably wider portion represents the handle (this is the inner portion), and the narrower part that is outermost suggests the blade of the knife. It is for this reason, in our opinion, that they are called "the knives."⁵ Some raptorial have longer or shorter clefts (emarginations) and some broader or narrower blades in these feathers. There are six of these emarginate, knife-like feathers in the wings of hawks and sparrow hawks. The four nearest the swing⁶ feather are incised on both webs, while the swing (*saxellus*) itself has only the inner edge reduced and the sixth knife-like rudder is affected only on the outer margin. In the hawks the fourth and fifth primary quills are the longest; the third and sixth are shorter and equal to each other in length; while the second and the seventh are of almost the same length.

Among the falcons, however, three only of the ten primaries are emarginate (or knife-like), i.e., the swing feather and the next two. That contiguous with the swing feather is the longest feather in the wing of the true falcon.⁷

In addition to the twenty-six feathers here described, there are four small but stiff quill feathers adjacent to the larger ones. These are attached to the small, outer bones of the wing that take the place of the thumb. These four feathers are called *empiniones*⁸ in the

⁴ *forinseca*.

⁵ *curtelli*.

⁶ So called from its chief function.

⁷ With these words there ends a passage (Bologna MS., fol. 28^r, col. 1), beginning in the previous paragraph with the words "there are six of these emarginate," which does not appear in the Vatican text.

⁸ The "bastard" or "false" wing of our author (*alaspuria sive alula*).

language of the falconer. They are larger than the contour feathers proper and smaller than flight pinions.

CHAPTER LI

OF THE ARRANGEMENT OF THE FLIGHT FEATHERS

The attachment of the large wing feathers is as follows: beginning with the outer feathers and proceeding inward toward the body of the bird, we have the last of the primaries (called the *saxellus*) or swing feather, attached to the last bone of the third wing joint. Its barrel lies lengthwise along the bone and reaches as far as the point where the latter is joined to the other bones of the wing.

To the adjoining bone are attached three large flight feathers not so firmly affixed to the bone as the swing feather is to its osseous base; but these three and the *saxellus* are set closer to each other than they are to the remaining six primaries. These latter rudder feathers are inserted into the neighboring bone,¹ but not so rigidly as are the aforementioned three. In this manner are arranged, side by side, the ten large flight feathers (primaries), which we have called the outer ten, inserted in three bones. They are more closely placed than are the other (neighboring) feathers.

When the wings are expanded each feather makes an acute external angle and an obtuse inner angle with the wing bone that underlies it, with the exception of the *saxellus*, that lies so closely attached to the bone beneath that it forms no angle therewith.

Inserted into the whole length of the ulna, the outer bone of the forearm, are the twelve flight feathers called *vani*, or secondary rudder pinions. These are all alike in form and color, but differ from the primaries. Each of

¹ Metacarpus.

them makes (in the outspread wing) a right angle with the underlying bone. The remaining four flight feathers that adjoin the secondaries are called *corales* (tertiaries);² generally they are different in form and color from the *vani*.

All of the twenty-six feathers are attached to the integument of the wings, the barrels piercing the skin, after which they rest against the bone. The swing feather, as previously described, is the only one adhering rigidly to the bone. Over and under these twenty-six quill feathers, one finds other, smaller, quill-like feathers (coverts) that are somewhat stronger and coarser than ordinary contour feathers.

The feathers that lie over³ the ten outer quills are inserted between each two quills and overlap them laterally; they are attached to the bone as firmly as or even more rigidly than the large flight feathers. The under coverts adhere each to the primary quill beside which it lies. They are attached to the barrel of the quill but do not extend to the bone. These coverts are smaller, weaker, and more slender than the upper primary coverts.

Those feathers that lie above the secondaries (*vani*) and tertiary (*corales*) do not overlap them laterally but lie one small feather over each large one, and extend as near the bone as they. The small feathers under these two sets of remiges are similarly attached; that is, they do not overlap them laterally but lie directly under them. They are inserted not along the bone itself but in the inferior muscle, and are smaller and weaker than those under the first ten large flight feathers.

Above these smaller quill-like feathers that lie above and below the flight feathers there are arranged, in orderly sequence, small feathers and plumae, reinforcing each other, until the whole wing is covered and protected.

² These are true *remiges* and grow from the upper arm.

³ Upper primary coverts.

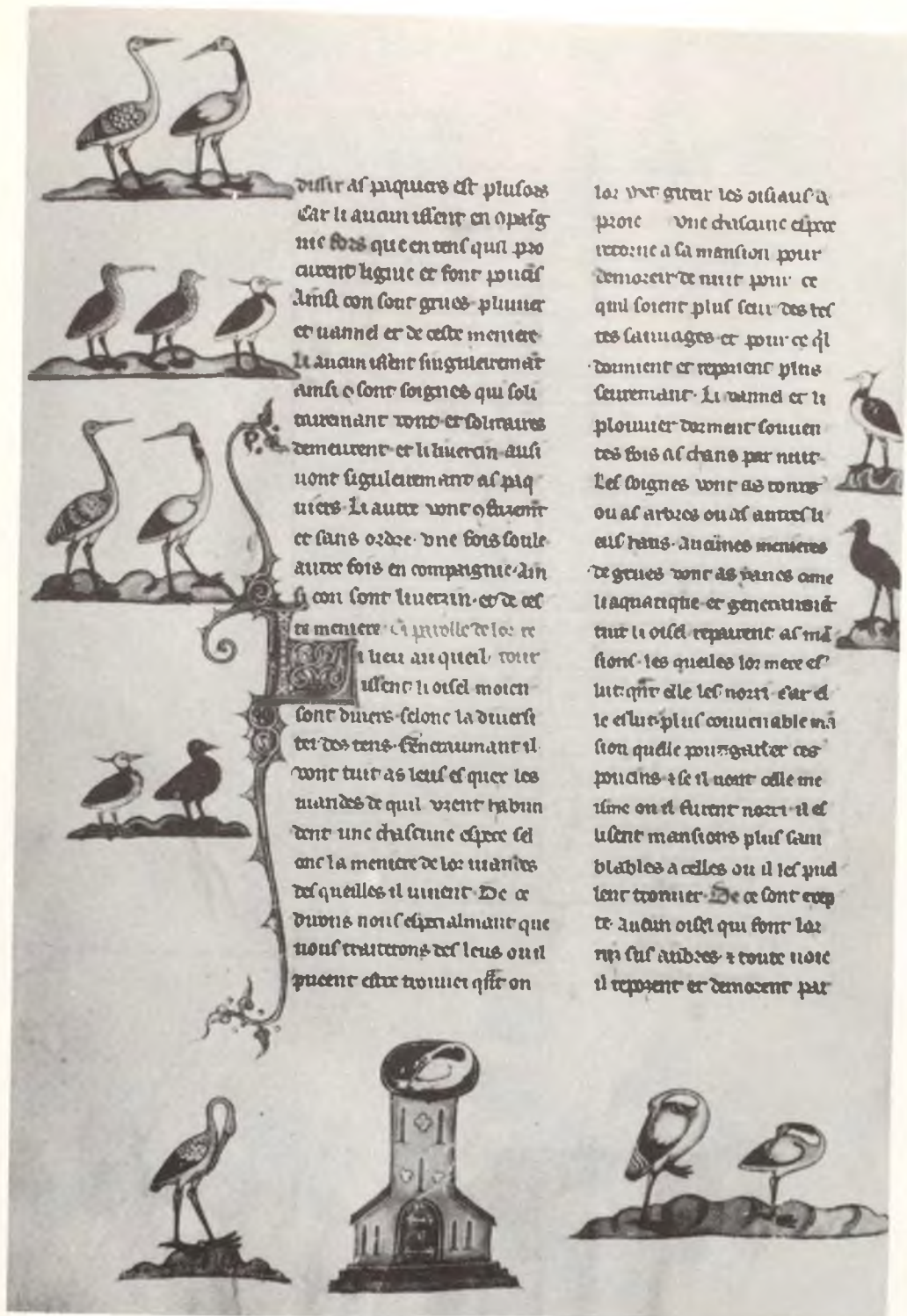

d'ist al paquars est plusors
 car li aucun istent en o paig
 me fides que en tel qui pro
 cuent ligue et font poual
 ainsi con sont grues pluuier
 et uannel et de ceste maniere
 li aucun istent singulièrement
 ainsi o sont soignes qui soli
 tement vont et solitaires
 demeurent et li liuerain aussi
 uont singulièrement al paq
 uiers. Li autre vont o fuent
 et sans orde. Une fois soule
 autre fois en compaignie. An
 si con sont liuerain et de ces
 te maniere. **L** parolle de lo: re
 li lieu au quel tout
 istent li oisel moien
 sont diuers selonc la diuersi
 ter des tens. fencrauant il
 vont tuit as leus et quer les
 uandes de qui vient habun
 dent une chascune espere sel
 onc la maniere de lo: uandes
 des quelles il uient. De ce
 diuis nous especialment que
 nous traicterons des leus ou il
 puent estre trouuer qst on

lo: vnt giter les oislauf a
 proie. Une chascune espere
 recoit a la mansion pour
 demorer de nuit pour ce
 qui soient plus seur des tel
 tes sauages et pour ce qd
 dormient et reposent plus
 seurement. Li uannel et li
 plouuier dorment souuent
 tes fois al chand par nuit.
 Les soignes vont as toures
 ou al arbres ou al autres li
 eul rans. Auaines manieres
 de grues vont as rans come
 li aquatique et generalment
 tuit li oisel repaurent al ma
 sion. les queles lo: mere et
 luit qst elle les noit. car el
 le est li plus couuenable ma
 sion quelle poungatier cos
 pouans. si il noit celle me
 rime ou el furent noit. il et
 istent mansions plus sau
 blables a celles ou il les pud
 lent trouuer. De ce sont excep
 te aucun oisel qui sont lor
 nis sus arbres et toute uoie
 il reposent et demorent par

PLATE 55.—Page discussing the return of birds from their feeding grounds
 (Bibliothèque Nationale MS. Fr. 12400, folio 20v)

uos capite & aqua timet
 & circa aquas deorsum si
 ut dicitur in capitulo de dimi
 sione animi. pueri tunc a
 uium ad aquas confugiunt q
 dum p. defensione sua. q. tam
 p. alio. q. dum p. utroq. Ite
 uero q. nate sunt in arborib.
 ad arboris confugiunt. ut
 modi cornicini. p. alio. & ab
 oz. plium. Et ille q. nate su
 nt in arborib. q. nate su
 nt in arborib. confugiunt. q. n.
 ad aquas q. n. ad arboris ut mo
 di. apromil. Si uero nate s
 sup. p. alio. fructus. aut du
 mos ad ea confugiunt. ut
 modi. struelli. & auiculari
 plures. q. nate sunt in p. alio.
 ad arboris confugiunt ut in
 p. alio. sed q. nate sunt sup.
 frum. & sunt colub. natus
 & tam. lanthane. & de re
 comendans. ut p. alio. co
 narmites. copuro. natus. &
 p. alio. calandae. & auicelle.
 plures. & quib. multe uide
 adeo. p. alio. in cauea sua. q.
 aduicite. & esse securus. in
 ra. capiunt. etiam manibus
 hominu. q. n. insequit. eis
 caput. ad frum. confugiunt.
 Perdices. fassani. & f. ind.
 q. n. sunt aut. uolatus. & p.
 aduicorum. loci. q. n. de.

sionem sic nūq. tenent. recedunt
 longe a loco. ap. defensionem
 suam. defensionibus. & pugna
 tenent. p. alio. genit. un.
 natus. p. alio. anim. q. n. plu
 rib. q. n. p. alio. dicitur.
 Op. natus. autem. defensionem
 in. alio. anim. & p. alio. ut. die
 in. die. & in. alio. comp. natus.
 est. p. alio. defensio. emittit. lo
 ge. & de. strone. suu. in. alio.
 rapaces. que. p. alio. q. n. eis.
 Quis. uero. uideat. & natus.
 comp. natus. conf. uideat. rapa
 ces. h. natus. plures. ag
 fando. se. & eleuant. alio. de. po
 nendo. caput. ad. modu. gallo.
 pugnantu. quod. p. alio. natus.
 rem. facit. & tam. uideat.
 de. & natus. comp. natus. con.
 uideat. rapaces. p. alio. natus.
 & p. alio. natus. rapaces. uideat.
 & alio. natus. que. refugit. ad
 fornicatu. & con. natus. uideat.
 alio. natus. h. natus. ut. in. alio.
 secunde. h. natus. & p. alio. defen
 sionem. h. natus. sunt. colub. g. n.
 co. struelli. & alio. fecit. om.
 imo. etiam. tota. agmina. in
 se. ip. densius. se. condit. natus.
 uideat. rapaces. facit. in
 sulcum. i. ca. q. natus. in. loc.
 natus. natus. h. natus. signum. e.
 q. natus. sunt. h. natus. anim. q.
 concurrat. ad. defendendu.



PLATE 57.—Folio 43, Vatican Codex, Pal. Lat. 1071, showing how various species of birds protect their young



maus pies et plusour au
 cer. Li auai se defendent
 en volant au plus haut
 et se est en y meneres. Car
 aucune fois il montent
 droit. ainsi com sont coulo
 et tourterelles et pames
 champêtres. i aucune fois
 il montent en volant a
 lenuion de lor pour lor
 defendre. ainsi com sont
 haïron. li quel vient de
 double defension. li com
 nous auons dit. c'est a la
 voir par vol de guerdur
 et par monter et tuit cil
 qui se querent defendre
 en volant montent par en
 haut pour ce quil ne pui
 sent estre sormonter ne vai
 cu par les oisiaul de proie.
 Aucun sont qui querent
 lor defendre en volant vers
 les leul. ainsi com sont or
 es. lames et plu sont autre
 de riuieres qui volent vers
 les leul ou sont les paves
 grant. li bois li roiaut et li
 des quer li oisel de proie se doucent
 a la voir ce quil ne desbat. a ces leul

ion. Des quer lieul se dou
 cent li oisel de proie. Car
 en ces leul il se doucent des
 cendre et apocher. Li au
 cun pour lor plus grant
 sauter font lor vol pres
 de la nuit et par nuit. am
 si com sont nories putes
 droctes lucarin qui pour
 ce quil sont piousculs volent
 de nuit plus seurement.
 Quant li autre des quer il
 se doucent sont arcepus de
 la menace de la defence de
 out duos oisiaus
 de la menace que
 ament li oisel pour lor des
 fence en refuiant as lieul
 seurs. Tuit li oisel generau
 mant se il pueent refuier
 as lieul de lor maruiter
 ou a lor semblables. Cil q
 sont nei pres des paves et
 fuert as paves. i de ces au
 cun se defendent en nout
 seulement. ainsi a li palle
 aint. Aucun en lor pliant
 de tout en tout deduis les



PLATE 58.—Part of the discussion of bird self-defense—by flight and by seeking a
 water refuge (Bibliothèque Nationale MS., Fr. 12400, fol. 68^r)

Besides these feathers there are others called *empiniones*, placed as we have already explained.

All these feathers are so arranged, one beside the other, that when the wing is extended the inner half of each pinion, beginning with that farthest from the body, is overlapped by at least the outer half of the feather next succeeding it, and so on in regular order, with the result that no spaces are left that would impede flight.

The barbules of the outer vane of the flight feathers, especially of the *saxellus*, are shorter, thicker, and harder than those upon the inner side of the shaft. This is imperative, since this side of the pinion is uncovered and exposed to attack by wind and storm. It is to be noticed, also, that the farther a quill is placed from the wing feather the wider and weaker it is, a phenomenon that is repeated in the tail.

When the wing is folded and drawn in against the body of the bird, the tertiaries cover the secondary remiges, and these in turn protect the "knife-blade" quills (or primaries). In this manner the three groups of feathers help in the best possible manner to reinforce and shield each other.

When the bird extends its wings in flight the tertiaries serve to fill the space nearest the body and to sustain the bird in the air. Were these feathers absent there would be a wide space between the body of the bird and the point where the secondary flight feathers begin, through which would pass wind, fog, and rain water (all harmful to sustained flight). Also, when the wing is folded in repose, both the bird's back and the secondaries [were there no tertiaries] would have insufficient protection.

The chief purpose of the secondary remiges is to support the bird in the air when the wing is expanded and in action. They also assist forward motion; and when the wing is folded they cover the "knife-blade" feathers and, in fact, all ten outer quills (the prima-

ries). These latter ten quills, when extended, help to sustain the weight of the bird in flight; but their chief function is to give a forward impulse. By the semicircular motion of all the primaries (parallel with each other) the weight of the body is raised. As has been explained in the chapter on the use of the various members, the greatest lifting power and driving force is exerted by the feathers farthest from the bird's body. It is for this reason that if one of these quills is missing it has a more detrimental effect upon the flight of the bird than if a secondary pinion were lost; and the damage is most serious when it is one of the outer primaries that is missing. When the wing is folded these ten quills cover and protect from cold the sides of the bird where there are few feathers and little down.

As the bird makes a descent it draws in and closes its other wing feathers but extends the *empiniones* (the bastard wing). Were all the wing feathers extended, the on-rushing air would lift the bird and hinder its descent. Were they all closed (both quill feathers and the bastard wing), the bird would fall, heavily in fact, and be without power to direct or control its landing. But with the *empiniones* alone expanded, descent is not obstructed but is controlled and directed to whatever point the bird desires.

The remaining wing feathers (the coverts) above and below the quills help to close any gaps between the shafts of these large flight feathers and to strengthen them.

CHAPTER LII

OF THE NUMBER OF TAIL FEATHERS

Birds of prey have, as a rule, twelve feathers in the tail, although sometimes they number thirteen or fourteen, or less than twelve, according to the excess, or deficiency, of formative matter, as we sometimes notice in hu-

man fingers or in the horns of the ram. In the case of nonrapacious birds there are often more (than twelve) or these may be fewer. It may here be mentioned that under the name "tail" we mean sometimes only the caudal feathers, on other occasions the whole organism out of which they grow and form a part. The oil gland is placed in both the male and female over the coccyx.

CHAPTER LIII

OF THE POSITION AND FORM OF THE TAIL FEATHERS

The tail plumage is so arranged that along the center of the rump two feathers are inserted that cover the others when the tail is not spread; these are called the "cover" feathers.¹ The right plume in its normal state overlaps the left. In most birds of prey with which we are acquainted these tail feathers are longer than the others, but in some species they are either longer or shorter. In addition to these covering rectrices there are ten more, five on either side, that are called the "covered" feathers (when the tail is not expanded). The tail "covers" (the central rectrices) are equally filamentous on both sides of their shafts, but the barbules of the inferior rudders are longer on their inner than on their outer aspect; and the more distant their position from the center of the row the narrower is the external filamentous portion of the feather; inwardly, however, the barbules are longer and softer. This appearance is well marked in the right and left outer quills of the tail and is in conformity with conditions present in the external flight feathers of the bird's wing. When the twelve caudal feathers are spread out fan-like for flying, their free

¹ *co-opertoriae*; these are the central rectrices or rudder quills, not what are usually known as covert feathers.

ends describe in falcons the sector of a circle, in some species large, in others small. In the smaller hawks and sparrow hawks they are in a straight line. There are also birds whose fan-shaped tail makes not an external but an internal concavity (or bow) because the central feathers are shorter than the outer.² There are also nonraptorial birds that have variously shaped expanded tails.

Above the twelve rectrices, or rudders, there are much smaller feathers; and underneath the tail there are others,³ usually whitish, that are much longer and more delicate than the feathers above the tail. These under tail-coverts are called, in the language of the falconer, *bracalae* (feathers of the breech).⁴

The tail has a manifold function in birds. When expanded it partly sustains the weight of the body and diminishes the labor of the wings as they propel the avian body in any of the four directions—upward, downward, right, or left.

The feathers over the tail and the vent feathers close the spaces between the twelve caudal quills; they also protect and keep warm the site of their insertions. There are birds in whom there are no large tail feathers, although they have large, heavy bodies, as cranes, bustards, swans, geese, and ducks.⁵

As a rule, waterfowl have shorter tails than other birds. Some species have, compared with the size of the body, long tails, e.g., magpies. The quill feathers of the tail, like the wings, vary greatly; they may be long or short, delicate or coarse, broad or narrow.

² In the (red) fork-tailed kite (*Milvus regalis*) and the black kite.

³ These are the upper and under tail-coverts (rectrices).

⁴ The vent feathers.

⁵ The tail feathers in these species are undeveloped only as compared with the caudal appendages of other birds.

[Supplement by King Manfred:⁶

Waterfowl, land birds, and neutral birds have some of them short, others long, tails. Aquatic (and some neutral) birds—swans, geese, ducks, cranes—have short tails. On the whole, the tail is short in waterfowl, as well as in neutral and land birds (whose habitat is either land or water) that live on fish or (grass) herbage. The following is the explanation of these facts: In the first place, just consider the help a long tail provides when the bird rests not only on high cliffs but on lofty trees and then flies off with the tail as a (rudder) steering apparatus, or when simply roosting the tail certainly acts as a shield against gusts of wind and other insults. In the second place, consider the advantage of a short tail borne by those birds that walk about on the earth in search of food and move around mostly in the early morning when the herbage is covered with dew; a long tail would soon be wet through, and the return flight to their usual roosting place in that condition would be more impeded than helped. If this be true of those birds that live on herbage, how much more undesirable would long tails be for those species that fish and spend most of their time in the water.]

CHAPTER LIV

OF MODES OF FLIGHT IN BIRDS

After a consideration of certain organs in birds, of their modifications and their functions, not to mention their plumage, there still remains the study of flight itself, which is founded on the subjects already discussed.

Although flight is progress through the air by means of wings, comparable to walking along the ground with the aid of feet, it is not

⁶ This passage appears only in the Vatican Codex and those manuscripts and editions that are derived from it. Cf. Vatican Codex, fol. 36^v, col. 2, l. 10, or Velsler edition, p. 113.

correct to regard every winged creature as a bird; for many animals that do not belong to an avian species have wings. Yet every bird has wings. But to be called a bird it must have also well-marked down and flight (quill) feathers.¹

Some birds move their wings in a well-defined, monotonous manner during flight and do not alter these movements except from sheer necessity; others use their wings with ease in all directions and change their motion without apparent purpose. The former may use their flying apparatus either much or very little.

In comparison with the size of their bodies some birds have short wings with relatively short primary flight feathers, while others have long wings bearing short primaries. Both types of bird are unable without repeated and hurried wing strokes to fly forward or to remain easily suspended in midair. They require to flap their wings all the more frequently if the flight feathers are thin and delicate or have natural or accidental vacant spaces between them. If the pinions are stiff and coarse and without gaps there is less need for frequent wing movements.

The necessity for rapid wing strokes is seen among water birds—ducks, geese, ganders, and coots, and such neutrals as plovers—also among francolins, partridges, pheasants, quail, and little (lesser) bustards.² Also, in every species one notices variations in the wing beats of individuals.³

Certain birds have longer wings and pri-

¹ Struthious birds—the ostrich, rhea, emu, apteryx, cassowary, *et al.*—have contour feathers and down indistinguishable from one another; but of course the Emperor knew nothing of South American or Australian species, and may not have closely examined the African ostrich.

² This whole passage (from the beginning of the chapter to this point) is repeated at the end of Book I in the Bologna manuscript, obviously a scribal error.

³ Schöpffer thinks this abnormality may be due to a temporary paresis, to a permanent paralysis, or to weakness attending an advanced moult.

mary flight feathers than their body measurements seem to demand; others, again, have short wings with long quills. These are all able to float in the air and fly quickly forward without oft-repeated wing strokes. When, as stated, such birds have strong and well-fashioned quills with no vacant interspaces, they need for long and effective flight comparatively few wing beats. But if, with a similar arrangement of wings and pinions, the latter are soft and slender or with broken spaces, the bird cannot maintain a forward motion or remain long in the air without wing motion.

Heavy birds with short, relatively soft wings must naturally employ rapid wing beats in flying, otherwise they would fall to the ground, as all weights are attracted to the center of the earth. Examples of birds that do not make frequent strokes with their wings are the herons (both white and gray), the *albani*, screech owls, kites, and many other aquatic, land, and neutral birds.

Large birds with a long wing sweep do not need rapid wing strokes, as they describe with their flight feathers a large semicircle covering a wide space; also their wings are slowly drawn against the body to repeat the movement, avoiding the need for frequent motion. On the contrary, birds with short wings and flight pinions, because of their short wing sweep, require an oft-repeated motion. And once more it may be stated that the frequency of wing motion varies with individuals of the same species.

[*Addition by King Manfred:*

Birds with long wings and perfect flight feathers sail along by backward strokes of their wings as if to set the air in motion. The longer the wings and the more nearly perfect the pinions, the more support is given by the spreading out of the wings and these back-strokes of the latter on the air, thus reducing the necessary number of beats. It has, in this connection, a resemblance to the relative

movement of a broad and of a pointed piece of lead; the downward fall of the former being slower because of the greater resistance of the air, as noted by the philosopher in his work entitled "On the Heavens and the Earth."]*⁴

Now when birds have their wings and flight quills in proper proportion to their body (neither too short, nor too long), their wing beats describe, in correspondence, neither a wide nor a narrow arc, nor are they of a rare or great frequency. When they have perfect, stiff quill feathers, they do not require to flap their wings as often as must those birds whose pinions are not so well developed. The wider and stiffer the flight feathers, the less frequent is the wing motion. The reverse is true in birds that possess soft, narrow pinions. Birds displaying moderate wing movements of this sort frequently belong to a genus of falcons. On the whole, it may be said that the longer, more complete, and rigid the bird's flight feathers, the better it flies; and the opposite holds true.

From all this the mode adopted in flying by certain birds is made clear, and it may, in addition, be stated that in case of desperate need they may change their manner of flight; for example, when they are urged by excessive fear, birds beat their wings as fast as possible; and this rule holds true of birds of prey engaged in chasing their quarry. On the other hand, when they have a long journey (as during migration) before them, they husband their strength, both coming and going, and do not tire themselves by wide wing beats; hence they are able to complete such excursions with ease. It is to be noted that raptorial birds, especially those that have interspaces in their wing feathers, like the hawks and the sparrow hawks (*Accipiter nisus*), after an exhausting hunt for their prey which they have failed to catch, soar

⁴ This passage by King Manfred is taken from the Vatican Codex, fol. 38, col. 1, l. 25.

about in the air with outstretched but apparently motionless wings. On these occasions they seem to be taking a rest. When the same species wish to rise high in the air by making a spiral ascent (or by "ringing up"),⁵ they change their mode of flight. Hawks and sparrow hawks by rapid movement of the wings can gain a great altitude; then, after a period of frequent wing beats, they rest, circling about on outstretched motionless wings. If they wish to rise higher, they repeat the motion, then circle again and rest. They do this because they tire from too prolonged and rapid flight. Thus it seems that quick movements of the wings are induced by fatigue and fatigue itself precludes a protracted period of rapid movements. This forces the bird to change its mode of flight and to take a rest. In going to perch the wings are as a rule held extended and motionless in order to effect a safe landing.

Birds that change their style of flight for no imperative reason, but because it is a normal process with them, do so in various ways. Some attain speed by rapid wing beats, then, folding their pinions, dive through space, and thus reach their objective. Among such birds are the long-eared owls (*noctua*) and some small birds. There are others that in flying beat their wings sometimes in rapid succession, sometimes not so often, and then with folded wings fly forward, and thus continue their flight in (interrupted) uneven lengths. Examples of this style of flight are the magpies, jays,⁶ and hoopoes. These birds cannot, because of their short wings and primaries, and the interspaces (*lacunae*) in their flight feathers, long sustain rapid progression and uniform wing beats; so they must vary them, as explained.

There is a Syrian pigeon⁷ which in the

⁵ The falconer's term for this rapid, spiral ascent.

⁶ *jahyus*, a word of which the origin is unknown to us; Pacius suggests "nutcracker."

⁷ The tumbler pigeon.

course of its usual flight forward suddenly turns over two or three times as if it were bewildered, and then resumes its usual course. We do not know why it does this—perhaps because of good spirits and cheerfulness. Other examples of unusual forms of flight we do not mention because they are too numerous and a recital of them would be tedious.

To sum up—some birds have a rapid flight, by which we mean they cover a long distance in a short time; others, contrariwise, fly slowly. Strong birds with a well-developed muscular (*carnosum et lacertosum*) breast, as well as compact, stiff, and long primary flight feathers, fly rapidly. Those that exhibit infrequent wing beats are the eagles, bustards, pigeons, and the baldheaded vultures,⁸ as well as some water birds. These birds have large wings and long flight feathers with which they are able to describe wide circles in the air and to make rapid progress after the manner of galleys furnished with long oars. Provided in this way, certain birds fly fast and with rapid wing beats, as do geese, ducks, plover, the lesser bustards, francolins, pheasants, partridge, and quail.

Weak birds with undeveloped breastbones and soft, flexible flight feathers exhibit a corresponding lack of flying powers, and have a languid, leisurely kind of flight. These include all the herons, the *albani*, and the screech owls, especially those that sail along by means of occasional wing beats. On the other hand, among those that utilize frequent strokes of the wings are mergansers, coots, land and water rails, the so-called birds of paradise from the Orient, and some other waterfowl and land birds.

Other birds, in their efforts to avoid capture, turn and twist in their flight when followed by predatory enemies. They have a

⁸ The text reads, *galerani campestris et aquatici*. We give here Schneider's translation. Webster adds the brown vulture (*Vultur monachus*).

slow wing beat and small bodies, so that they are not prevented by the rate of wing movement or the size of their bodies from turning quickly and dodging. These birds are herons, *albani*, screech owls, crows, hoopoes, kites, lapwings, magpies, and other small and medium-sized birds. Other species continue their original direction when pursued by birds of prey, and these are as a rule such as have command of rapid wing movements and are prevented thereby from effecting rapid changes of direction, e.g., geese, ducks, plover, francolins, partridge, and quail. Birds that are unable because of their large size and heavy weight to fly away in the distance and escape (despite rapid and increased flappings of their wings) are the swans, pelicans, bustards, cranes, and similar large and heavy birds.

The duration of flight varies in bird species. Some are able to continue it for long periods; others are soon exhausted, so much so that they can be captured, if not by the hand alone, by the help of dogs. The latter class includes pheasants, partridges, quail, and francolins. On the whole, it may be said that those species that persist in flight for short periods only move their wings rapidly; the reverse, however, is not true, for certain birds with rapid wing beats fly continuously for long periods; but no birds with a slow wing beat are found whose flying powers are limited to short flights.

The explanation of this abbreviated power of flight is that in all birds exhibiting that variety of weakness the wings are small compared with the size of the body; their primary flight feathers are slender, with many lacunae in them, requiring repeated strokes to get results; so they are easily fatigued and they cannot remain in the air. Owing to the disproportion between wings, plumage, and body, they are obliged to return to the earth.

Birds that are able to sustain long, continuous flights never become so exhausted that

they can be caught by men or dogs, examples of which are seen in herons, eagle owls, and kites. In comparison with the size of their bodies they have long wings and well-developed pinions. Among those birds possessed of a slow, infrequent wing movement those that move their wings most rarely can maintain the longest flights and accomplish the most distant journeys. This applies to individuals as well as to species. By the aid of favoring winds, such birds as quail, whose usually short flights are made by rapid wing strokes, undertake long journeys (as when migrating or returning to their nesting places). On such occasions, however, they take their time and husband their wing power as they fly from island to island.

Birds with long wings and good flight feathers fly better with the wind than those with short wings and pinions, even when they both fly equally fast without the aid of the wind. However, short-winged birds fly better against the wind than those with long wings, even if both species progress equally fast in the absence of a stiff breeze.

Also, birds with rapid wing strokes fly better against the wind than those with a slow wing movement; and there are small birds of every species that make better time in defiance of an adverse wind than do larger birds.

Waterfowl suffer least from heavy showers of rain; in wet weather the bird with its first supply of feathers is more affected than after it has moulted. The second plumage, if well developed and still fresh, is less likely to be affected by dampness than the older covering.

Birds who fly only by day may be placed in two categories. Magpies, pigeons, sparrows, and most small birds have no definite time schedule, whereas others fly only in the early morning and toward sunset. In this second group we find those who feed in the early morning, aquatic birds who feed on land in the evening hours, and many neutrals and

land birds who are afraid to fly at midday [because they feel heavy after a full meal and are sluggish and less able to escape from eagles and other birds of prey that are in the habit of soaring aloft, especially on hot summer days when they cool themselves and ventilate their wings.

There is another obvious reason why most birds take a rest in the daytime: After digesting a full meal during the night, in the early morning they are again hungry and fly to their feeding grounds, where they enjoy a comfortable meal that demands undisturbed quiet for its digestion.]⁹

Some species find frequent excursions at night (or in the gloaming) more to their taste, as do long-eared and eagle owls; they fly about like bats, not so much because they see best in the dark but because they fear the persecution of birds who dislike and worry them.¹⁰

Other birds, such as snipe, fly around both day and night. Birds of all sorts take advantage, either by day or night, of favoring winds during their migration, as has already been noted. Domestic fowl, partridge, pheasants, peacocks, quail, and similar birds (that are heavy weights and poor fliers) always keep near the ground so that they may quickly reach a refuge in time of need. Raptorial as well as peaceful birds that are light on the wing and good fliers ascend high into the air on the lookout for food. This habit coincides in birds of prey with their sharp eyes. Birds that soar to great altitudes fly either straight ahead, like the screech owls, or in circles, ringing up, like herons. If birds wish to take advantage of a favoring breeze they often rise high in the sky; but if the wind is adverse they generally remain lower down,

because at a great altitude wind has greater force. Some birds choose a solitary flight like the birds of prey. The reason for this is that raptorial birds attempt to seize the captured quarry of another. They therefore fear one another and fly alone in order to have uninterrupted leisure in which to consume their prey. They do not swallow it in large portions, but first deplume and then eat it bit by bit.

As a rule birds fly in flocks, especially those whose food consists of single grains that they pick up one by one and swallow forthwith. These associated birds pursue their journeys either in orderly fashion, like cranes, geese, ducks, and waterfowl, or in disorder, like sparrows, starlings, and pigeons, which to secure safety not only consort with their own species but keep company with others of a similar kind. Certain birds, like turtle- and ringdoves, fly sometimes alone, sometimes in flocks. During the mating season all birds pair off, a male with a female. When they migrate to avoid heat or cold and when they are not nesting they gather in larger flocks.

CHAPTER LV

OF AVIAN MEANS OF OFFENSE AND DEFENSE

The art of attack and of defense in birds is carried on by the aid of their own members, by flight, or by resort to a safe refuge. The parts employed in self-protection are the beak, the wings, the feet, and the talons, singly or all together.

The mandibles are called into play to stab, to bite, or for both means of assault, and they can be so utilized while flying or otherwise engaged. Birds with broad, dentated bills bite more often than they stab, especially when they are not in the air. When they are flying, swans, pelicans, geese, and ducks usually bite.

⁹ This passage (in brackets) is taken from the Vatican Codex, fol. 40^v, col. 2, and is substituted for a shorter one in the Bologna MS., fol. 32, col. 1.

¹⁰ Owls and bats also choose twilight hours for catching night moths and butterflies, of which they are both very fond.

Those birds that are armed with long, solid, and pointed beaks—storks and herons, for instance—use them chiefly for stabbing, whether flying or at rest, and bite only incidentally after stabbing. Birds like the raptors (especially falcons), with a curved, flinty, sharp beak, bite but do not thrust with it. They do this both in flight and when on the ground. Cranes, having long and firm mandibles that are neither broad, as in geese and ducks, nor sharp-pointed, as in storks and herons, stab more often than they bite, whether they are flying or not.

In general, birds with long and pointed mandibles stab more frequently than they bite; mergansers and cormorants—the latter are also called “sea ravens”¹—with long curved and sharp beaks stab when biting and bite when stabbing. Ravens and crows, having hard, sharp mandibles, stab as well as bite.

Birds that burrow in the ground for worms defend themselves with the beak very little or not at all, because, although it is long, it is soft everywhere except at the tip, where it is hard, round, and dull. This is true also of curlews, plovers, and lapwings, all of whom attack or defend themselves, whether flying or not, by blows with their wings, which are for this purpose armed with a hard and pointed spur, already described. Waterfowl, which also defend themselves with their wings, have this spur longer, harder, and thicker than have other birds, as seen in swans, geese, ducks, pelicans, and some land birds—pigeons and bustards, for example. Certain neutral birds, such as plover, lapwings, snipe, sandpipers, and species that bore into the ground, also fight with their spurs, striking, tearing, and clawing in all directions to repel the enemy in the air or on the ground.

Cranes fight with their feet in three different ways, as will be explained in (my) treatise

on hunting.² They either strike out backward while in flight, or when standing erect upon the ground lash out and trample with their feet, or, while lying on their backs, strike and tear with their talons. Herons, in defending themselves, use their feet only when lying on their backs, but do not gain much thereby.

Raptorial birds strike and inflict wounds with their claws, both while on the earth and in flight. Also it may happen that the feet of the fleeing quarry are grasped by the pursuing bird of prey and in this way the talons of each may be closely locked together.³ It rarely happens that one raptorial bird fights with another.

As a matter of fact, all birds defend themselves, but those without curved talons do not inflict serious wounds; they mostly press their feet against the breast of the enemy and try to push him off, a practice common to nearly all birds.

There are also birds that, springing up from the ground, attempt to throw an attacking bird of prey beneath them. Among these are the [large] bustards and the lesser bustards, the latter being similar to, but much smaller than, their relatives. The lesser bustards are known by their raucous mating calls in summer.

Birds seek also in many different ways to protect themselves (from their enemies) by flight; cranes attempt to fly off to a distant locality; partridge and quail quickly gain cover, while herons twist and turn during flight to escape, as do crows, hoopoes, lapwings, and magpies. Other species seek sanctuary in the upper air by one of two methods: either they fly straight up, like pigeons, turtle-doves, and the lesser bustards, or they ascend in spiral rings (i.e., ring up) like herons, who have in flight a second mode of escape, and

¹ Cormorants are called *Seeraben* at the present day in northern Germany, and are certainly the birds Frederick II here refers to when he says *corvi marini*.

² Frederick is referring here to Book IV.

³ In falconry this is called “crabbing.”

that is by dodging. All those that depend upon escape to the upper regions of the air expect to be able to maintain a position above pursuing birds of prey.

Other harmless species find refuge in localities which raptorial birds fear and, in consequence, avoid. Geese, ducks, and others resort to this maneuver, seeking neighborhoods where large bodies of water, forests, canebrakes, and reeds abound.

Finally, birds such as the long-eared owl, eagle owl, and snipe fly about for greater security in the nighttime, or at least during twilight.

CHAPTER LVI

OF THE LOCALITIES IN WHICH BIRDS SEEK SHELTER

As a general proposition, birds choose for purposes of defense their birthplace or a locality resembling it. Some aquatic birds, such as pelicans, seek the water because only there are they safe from pursuit; mergansers and ducks (among many others) dive entirely under water; swans and geese submerge themselves only partially. There are also others, neither swimmers nor waterfowl, who take to water when frightened by a bird of prey because they know the marauder dislikes or fears a ducking. The resort of birds to bodies of water is influenced also by their search for food.

Those birds that have been raised in trees, such as crows and magpies, seek an arboreal refuge, while others, whose home is near the water, like the herons, return to both trees and aquatic resorts.

If they are at home in meadows, shrubbery, or thornbushes, some species fly to them, as do thrushes, starlings, and many other small birds. Birds of prey born and raised in cliffs resort to these places of safety. Those whose habitat is terra firma have the color

of the earth and lie concealed on the ground, a habit with partridge, quail, crested larks, little bustards, wood larks, and many other species that are, in a sense, so stupid as to believe they are perfectly secure in this situation and are, in consequence, likely to be caught by the hand of man when taking refuge from a pursuing bird of prey. Partridge and pheasants, which do not fly long distances, find security near by and do not wander far from their own home refuges.

The majority of birds make more or less of a struggle to defend themselves. Some of them employ a peculiar and special means (among these are the bustards, great and small) by discharging their excrement on the pursuing robber. In their fear they also ruffle their feathers, behave in a wild fashion, raise their wings, and lower their heads like fighting cocks. The larger bustard also strikes the breast of its opponent.

Other birds take refuge among a flock of their own species, as do pigeons, cranes, and starlings, expecting to find there help and safety; indeed, whole companies of them form themselves into a defensive array when a raptorial bird appears on the scene.

A further proof that there is strength in union is furnished by the plan adopted by certain kinds of birds, among them cranes, geese, and crows, when they join their companions in protecting one of their number against a pursuing bird of prey by mobbing and attempting to kill it.

CHAPTER LVII

OF THE MOULT OF BIRDS

While it is true that birds shed their feathers every year, we must not leave it at that but must inquire further into the cause of this moulting, why it happens regularly each year, at what season it occurs, and whether it is completed quickly or gradually, and last,

but by no means least, discuss the alterations in plumage before and after the moult.

It is both necessary and useful that the bird should change its down, contour, and flight feathers, because they are reproduced by an overflow of humors and are composed of perishable matter subject to many hazards, and because this material can last only a year at most; if the moult is delayed any longer, degeneration of the plumage would set in and the feathers would then be so worn out and broken down as to be of little or no use to the bird. For this reason Nature has provided a substitute for them and brought about an exchange of the old feathers. The appearance of new feathers depends upon an abundance, even superfluity, of the bird's bodily humors regularly supplied. As evidence of this, should a falcon complete her moult earlier than usual, she may again shed some pinions (which had appeared in the premature moult).

This accident may be a result of the heat of the season, which opens the pores, as well as from too rich food, or from excessive humors.

It may be further remarked that when hairs of the human head and body are broken or cut, they grow again to their former or even greater length, for under the continuous flow of generative matter they develop to an indeterminate length. But in the case of feathers and quills this is not so, for these adjuncts have a definite size and form, and if broken cannot regain in toto the portion that has been lost. In time degeneration would extend to the barrel, and if other feathers were not substituted for the damaged plumage the bird would be without feathers or quills and entirely exposed to the inclemency of the weather and rendered incapable of flight.

Moult takes place every year; indeed feathers are not of much use longer than that period. In harmless birds the first plumage, after it has fully developed, is exchanged for

another supply which develops continuously and uniformly with the growth of the body. This second supply of feathers is completed during the first year in pheasants, partridge, and quail, and moulted at the end of that period.

The question why moulting occurs only once during the first year in raptorial species and twice during the same period in harmless birds has already been discussed in the chapter on plumage.¹ An answer to this query is that more dangers threaten harmless birds during the moulting season than birds of prey; for that reason the former need constantly both their down and flight feathers to insure safety and to procure food; and this is particularly the case when the parents do not supply their fledglings with nutriment. Again, these birds are by nature richer in humors than are raptorial birds and their flight feathers develop more rapidly than the remainder of the body and are thus somewhat weak and soft.² With continued development of the body these early feathers and pinions are unable to lift the increased weight and are moulted. Nature then provides stronger plumage capable of carrying the bird for the first year. The second supply of feathers then falls out and a third lot begins to grow and this provision lasts throughout the succeeding year.

Birds of prey are not subject to as many dangers, nor are they of such full habit, as are harmless birds; hence their feathers develop more slowly, grow more gradually, and, consequently, thrive more regularly and are in better proportion to the size of the body whose weight they are able to support until the end of the first year. Thus it is that the raptorial birds moult only once during their first year, afterwards changing their plumage annually, like most inoffensive species.

¹ Cf. Book I, chapter xlv, p. 79.

² It is at this point that the calligraphy of the Bologna text changes—Bologna MS., fol. 34^r, col. 1, l. 45.

The season for beginning a moult is, with most birds, the springtime, when there is on hand a good supply of food. During the following summer season they do not suffer from the cold and their flight feathers are so full grown that they are prepared for the autumn migration. Spring is, in fact, the only suitable time for moulting, as is explained in the chapter on migration. There are, however, some birds that do not begin to lose their feathers until the summer—following the rule that moulting largely depends upon the date they issue from the shell. When a bird moults it may do so at the end of the year that begins with the date of its birth. The same phenomenon is evident in the appearance of new leaves on trees and shrubs and a new growth of grass from the roots, which first sets in after the lapse of about a full year.³

There is a regular as well as an irregular form of avian moult. To the first class belong those birds in whom a number of feathers fall out at one time, followed by their immediate renewal, making them fit for flying before others are lost. The irregular kind includes those cases in which many feathers fall out, then another lot before the first loss is repaired.

Raptors (*Falconiformes*), that are in constant need of their flight feathers to aid in capturing their prey, have a regular form of moult, so that they never entirely lose their flying ability. Harmless birds that are not in such urgent need of wing power to gain a living (i.e., those whose provender does not fly away from them) moult in less orderly fashion; but as they require flying power to secure shelter and to avoid dangers, the moult is not entirely without plan. Waterfowl (i.e., swimmers), on the other hand, make a complete and unusual moult influenced by the

fact that they do not escape dangers nor obtain their sustenance by flight. By living in the water they attain both objectives.

A further study of the moulting process we shall defer to a later chapter on the moulting of birds of prey, concerning which we are much better informed than regarding that of other birds.

Here we remark, in general, how wisely it has been arranged that birds begin to moult their flight feathers before their other contour plumage. The former, much larger and longer, demand for their development and growth a greater expenditure of vitality than the latter; if the other feathers (or accompanying plumage) were the first to fall out they would have completed their moult long before the pinions had been replaced, and the renewal of the entire plumage would not have been completed at the same time, so that the flying powers of the bird would be lessened.

Water birds moult earlier than other birds, owing to the richness of their nutritional humors and fat; then come the harmless land birds, which also possess a large amount of adipose tissue; while birds of prey, the driest (i.e., those provided with the smallest amount of humors), are correspondingly the slowest to lose their feathers.

The length of the period from the beginning to the end of the moult, as well as the order observed in changing their flight and tail feathers, will be later discussed more fully and in its proper place.

The plumage of unmoulted birds differs from that of moulted fledglings in that, as a rule, the feathers after the moult are in better condition and are of a different color. They have more down around them and the new pinions do not get wet so readily, nor are they so fragile or so easily frayed.⁴

³ Here Frederick II adds: *Et hoc opinamur accidere ex motu superiorum et diversis aptitudinibus materiae in quam agit.*

⁴ Here the Bologna MS., from fol. 34^v, col. 2, l. 10, to fol. 35, col. 1, l. 11 (the end of the first book), repeats the passage contained in that manuscript from fol. 30, col. 1, l. 24, to col. 2, l. 1 (chapter liv).



PLATE 59.—Intermewed eyas peregrine, "Lady Mary," caught, trained, and flown by R. M. Stabler, Philadelphia, U.S.A., January 1939. (Courtesy of owner)

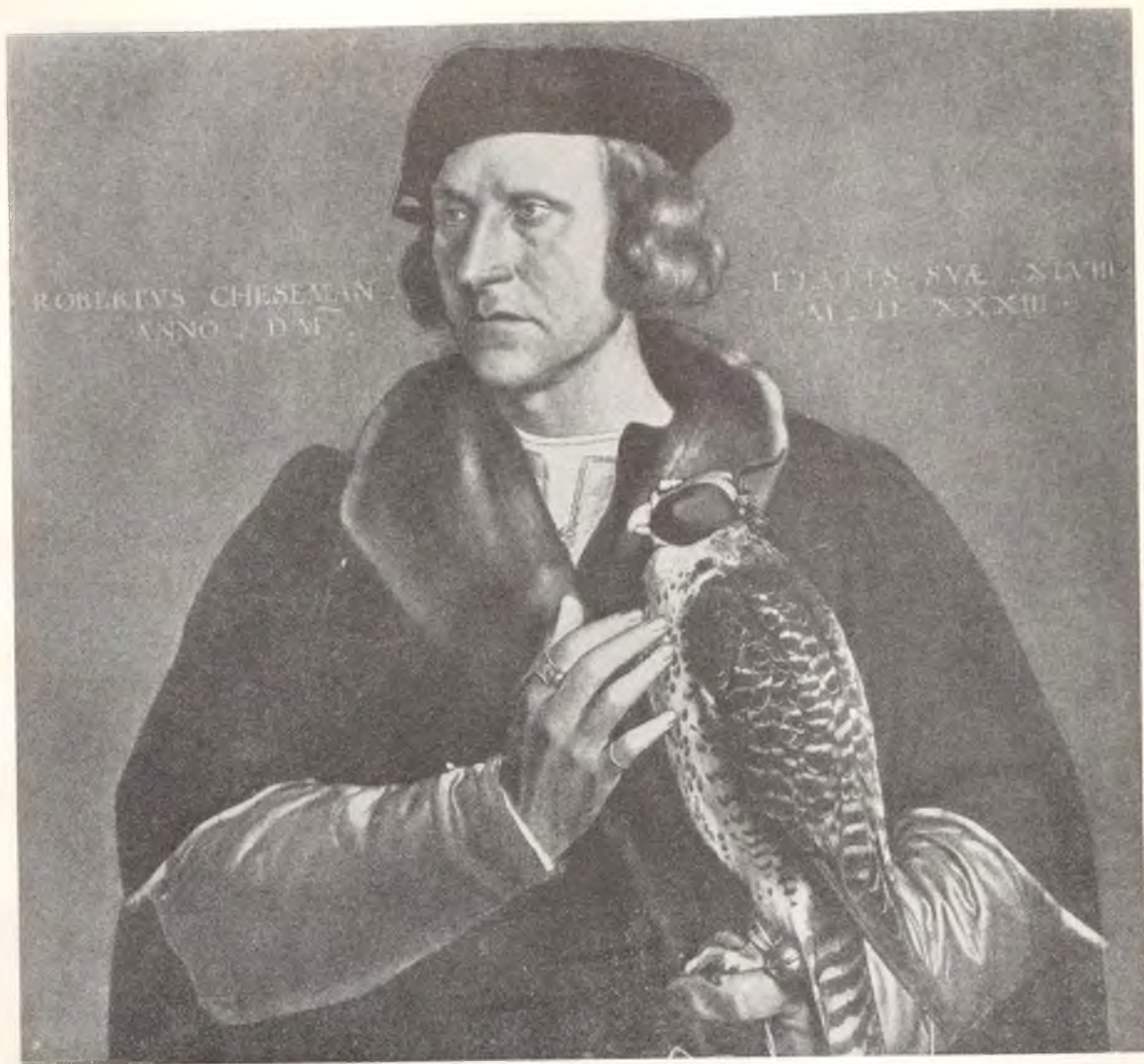

PLATE 60.—Robert Cheseman, falconer of Henry VIII of England. Painted by Holbein in 1533. (Mauritshaus, The Hague)



PLATE 61.—Philip the Handsome of Burgundy and his falcon. *Ca.* 1550



PLATE 62.—“The Hawk.” Engraving, after E. Landseer, R.A.,
by C. G. Lewis, London

BOOK II

OF FALCONS USED IN HUNTING, THEIR FURNITURE, CARE, AND MANNING

AUTHOR'S PREFACE

THAT falconry is a gentle art was maintained in the previous book, and its nature was discussed there. It was shown to consist chiefly of hunting nonrapacious birds with birds of prey trained for the purpose. It was claimed that this sport is a nobler form of venery than any other and, moreover, that a work of this kind in its very nature involves a study of water-fowl, neutral birds, and land birds, raptores as well as harmless species.

In the second part of this treatise—and in others—we arrive at the essential portion of our research, true falconry, including everything desirable for a man to know and to learn who wishes to understand and practice this art.

The requisite traits of the novice, who must begin his education under an experienced teacher, will be discussed later. It is self-evident that, having secured his falcons, he must first of all gain experience in the art. However, it is not everyone who can qualify for the practice of falconry; only an indefatigable, enthusiastic lover of it, who is fitted for the sport at the same time by instinct and by training, can succeed in it.

Although the birds of prey with which one hunts are mere instruments in the hands of a master, yet the skilled falconer should give his entire attention to them and to their equip-

ment. He must be tireless in watching and directing his falcons and in studying their deportment. These birds include not only falcons and hawks but also other raptorial whose performance we shall thoroughly discuss. For the art of falconry varies greatly according to whether one chooses to practice it with falcons or with the large and small hawks.

The art and science of falconry are further divided into *theory* (the general mental survey and understanding of the principles of our subject without reference to its practical application) and *practice* (the knowledge of how to put into operation the rules that we shall expound).

When a man without either theoretical knowledge (which must ever be a preliminary consideration) or practical experience undertakes to pursue the art of falconry, although he may secure good results in his hunting (just as in the gymnasium the inexperienced boxer may strike a good blow, or the unskilled archer may even hit the mark), we may well say of him that he is merely testing his luck and not his skill.

The falconer's primary aspiration should be to possess hunting birds that he has trained through his own ingenuity to capture the quarry he desires in the manner he prefers. The actual taking of prey should be a secondary consideration. He will, in this way, secure that threefold advantage that we have

discussed at the beginning of our first book. The falconer's postulates that he should ever bear in mind are set forth in this book of ours as examples and precepts covering the entire range of falconry. In stating them we shall observe such brevity as is consonant with our duty to preserve a constant clarity of expression.

The eye of envy will not influence us to be prolix, or guilty of repetitions or superfluities, or to talk on immaterial subjects. We intend to confine ourselves to matters that are relevant to the subject in hand.

The tasks of the falconer are numerous and of great variety. To begin with, he must make a study of birds of prey, then secure and carefully tame his hunting birds so that they will stay with him. To this end he must so tame them that they will lose their innate fear of man and of intercourse with him. Also, as a part of their education, falcons should become accustomed to be slipped from the fist and learn to return obediently to the hand when summoned.

As we have said, the falconer must also teach his falcons that they are to chase only birds of his choice and in the manner he desires. This is not an easy task, as it runs counter to their natural inclinations. To this end he should utilize items of information he has already gathered while engaged in other forms of venery. There are many other important duties incident to his career; he must, for example, insure the good health of his falcons, because their usefulness depends upon it; and he must learn how to treat birds that become ill.

After making a sufficient study of the foregoing tasks, as set forth in the various sections of this work, one may with confidence own falcons, since they will then be in safe keeping and be well tamed.

Among the various implements included in the expert falconer's outfit are devices for trapping his falcons, or hawks, such as nets

and snares; and in this connection it must not be forgotten that some birds of prey may be used to catch others; for instance, falcons are captured by hawks.

Other accessories are employed for the retention and accommodation of captured birds, such as the falcon sock,¹ jesses,² leash, and proper perches, as well as stools or blocks.³

Other devices are employed in taming wild birds; for example, the "tiring,"⁴ the hood,⁵ and the bathtub.⁶ There are also certain contrivances used in teaching the falcon to fly from and return to the falconer's fist. These include the line, or creance, and the lure⁷ (with or without meat attached thereto) that is used to recall the falcon.

There is still another device whereby the falconer summons the falcon that he is teaching to capture certain birds, namely, the train,⁸ a form of the lure—a decoy prepared either with a crane, a heron, or some other bird, or even with the straw-filled skin of a hare; for there are many birds that will "wait on"⁹ the train.

Among other contrivances used in flying the trained falcon are the small hand drum and the falconer's glove (or gauntlet).¹⁰

¹ *maleolus*; a close-fitting linen bag into which the recently captured falcon is thrust, leaving her tail, head, and feet free. See Plate 79 (p. 165).

² Footgear, made of a leather strap attached to the lower portion of the falcon's leg. See Plate 71 (p. 141).

³ *sedilia*; truncated cone of wood, or stone blocks, to be placed outdoors when the hawk is to be "weathered" or set out at hack. See Plate 73 (p. 147).

⁴ *viratoria*; pieces of meat, e.g., the fresh or dried leg of a chicken for a short (emergency) meal.

⁵ *capellum*; this most important, useful, as well as ornamental part of the falcon's dress is thoroughly described in Book II, chapters lxxvii and lxxviii, pp. 205-7.

⁶ *ina balneatoria*; Book II, chapter lxix, p. 191.

⁷ *loyrum*; cf. Book III, chapters i ff., pp. 225 ff.

⁸ *trahina*; cf. Book III, chapters xxii ff., pp. 257 ff.

⁹ "Wait on," a falconer's term meaning to hover on outstretched wings high above the falconer until quarry is flushed or the lure is thrown out.

¹⁰ *chirotheca*; used to protect the falconer's hand from the bird's sharp talons when resting on his fist.

For the conservation of the health of his hunting birds there are several provisions to be made by the falconer, especially while they are moulting their flight and down feathers. They ought to be kept in a small moulting-house or mews¹¹ that should be well stocked with remedial agents. In addition to remedies for healing the sick there should be provided suitable receptacles for administering them. A further description will, in its proper place,¹² be given of all these implements.

Abandoning our prologue, we must now return to our main theme. As a starting point we must define a bird of prey, for by definition and description all existing things may be fully explained. We shall also explain later why they are called rapacious, or birds of prey.

CHAPTER I

THE DEFINITION OF A BIRD OF PREY, AND THE REASON FOR THIS DESIGNATION

A bird of prey is a flying, feathered, land animal, swift of flight but awkward in walking, with a curved beak and talons. It preys on live animals, and the female is larger than the male.

Its ability to fly is founded on anatomical structures that differ from those of many nonvolant creatures. Inasmuch as rapacious birds are feathered, they are dissimilar to other winged animals such as bats, bees, and grasshoppers. For bats have featherless wings composed only of skin and cartilage, by which they attach themselves to walls, woodwork,

¹¹ *domuncula quae dicitur muta.*

¹² From this point to the beginning of chapter xxxi, the translation is entirely from the Vatican Codex, for these chapters were inserted in the treatise by King Manfred from notes found by him among Frederick's papers, as is explained by the King in chapter xviii, pp. 119-20.

and other structures, their weak feet being unsuited to clinging.¹

We call a land bird one of a species whose constitution is warmer and drier than that of waterfowl and neutral birds, for it cannot long remain in cold and wet localities that are adverse to its nature. Raptorials prefer dry and warm surroundings. Wise men have a saying that (animate) objects of similar form and nature flourish when associated, while those mutually opposed waste away. It follows, therefore, that birds of prey (that prefer warmth and dryness) should not be confined in unsuitable localities, that is, places opposed to their nature, for these check their development. No living being covets anything opposed to his nature; and even abnormal individuals, or beings under unusual influences, do so but rarely. It is well known to every falconer that if, for example, his hunting birds take to water they do so because they feel ill and hope in this way to cure themselves. Once cured they no longer seek what is contrary to their normal instinct, except for a very few individuals that, through taming, have acquired habits foreign to their nature or because of some latent malady.

Swiftness of flight is another peculiarity of birds of prey in which they not only differ from all unfeathered creatures but excel all other birds,² in both short and long flights. For though some birds may outfly certain raptorials in long flights, they are caught by others in short swift attacks; for example, the swift-flying ducks escape from hawks in a long flight but are captured by them in a sudden rapid onslaught. Falcons, especially the

¹ The Emperor is wrong in giving the bat alar cartilages. Moreover, bats hang by their feet, not by their wings.

² There is an inaccuracy in this statement. Some raptors, like the buzzards, have a comparatively slow, lumbering flight; while some nonrapacious birds, e.g., the common swift (*Apus apus*), fly so fast that few birds of prey can overtake them and even then only for short distances.

gerfalcon, catch them with ease in both long and short flights.

Falcons are, however, weak pedestrians, like most swift fliers. It appears that what birds gain in flight they lose in gait, an example of which one finds in the swallows, who are among the swiftest fliers but whose feet are badly formed for walking.³ The converse, also, is true.

And more specifically, a curved beak and needle-pointed talons distinguish birds of prey from many other birds—in fact, from nearly all other species. Although Aristotle has declared the converse to be true—that all birds with curved talons are raptorial—it is evident that, since jackdaws, starlings, and vultures have curved claws yet do not live by the capture of other animals, they cannot be called birds of prey. One may safely affirm that all raptorial birds have curved talons; but the contrary is not true, that all birds with curved talons are necessarily raptorial.

A further specific distinction is that birds of prey live by the capture of live animals, so that birds with curved claws, such as vultures and others (including certain species of geese)⁴ that live upon carrion, cannot be called birds of prey.

A peculiar and important characteristic of raptorial birds is that the female is larger than the male, a trait not seen in other animal species, in whom the female is always smaller than or at least of the same size as the male.⁵ As we have been frequently questioned in regard to this phenomenon by those who practice the art of falconry, we have fully explained the reasons we have discerned for it and have had them recorded in writing.

³ A safe generalization, numerous examples of which easily come to mind, such as, for instance, flycatchers and hummingbirds. Notable exception to this rule are the pigeons.

⁴ A careless statement. Geese never eat carrion but invariably live on plant life.

⁵ In the godwit (*Limosa*) and a few other (marsh) birds the female is slightly larger than the male.

CHAPTER II

WHY THE FEMALE BIRD OF PREY IS LARGER THAN THE MALE

It is recorded in many works of the philosophers¹ that heat is active and stimulates growth, a truism that appeals to us since we know that artificially heated fluids increase in volume even when nothing is added to them and they are not in any other way altered. Moisture is passive and receptive, so that under the influence of a moderate degree of heat the moist subject maintains a certain definite size. If, however, the moisture is increased in proportion to the heat (while the heat is maintained at a normal temperature), the subject expands beyond its normal limit. It follows, therefore, that the subject deviates from its normal size in the same degree that its moisture is great or small in relation to its heat content. On the other hand, the body is small when the humid content is less in proportion to the effective heat. If the heat is increased, the body will grow smaller. But if the moisture is in just proportion, the body attains its normal magnitude; whereas if the humid content is excessive, then the body expands beyond its normal size.

Now, birds of prey are of an exceedingly warm nature, since various sources of heat are united in their constitution. They are warm because they form part of avian life, and birds are of an even warmer disposition than the most active of ambulatory creatures. They are, moreover, rapacious; and this quality also is dependent upon extreme heat. That they hunt wild game and seize it demonstrates

¹ Chiefly Galen, who taught that, as in human beings, there are four *humors* (fluids) that largely control the life of animals, viz., blood, phlegm, yellow bile, and black bile. These vital agents correspond not only to the four *temperaments*—sanguine, phlegmatic, bilious, and melancholic—but are intimately associated with the four *qualities*, dry, cold, hot, and moist. Here and there the imperial author of the *De Arte Venandi* makes a reference (more or less veiled) to these early biologic hypotheses.

their bold, impetuous spirit that is also a result of warmth. Their whole constitution, therefore, may be considered warm in a fine and well-balanced fashion; and one must be held justified in maintaining that these birds are to be classed among those that possess the very warmest natures, since they unite in their natures so many sources of heat. It has often been observed that when many warm elements are brought together the temperature is increased, just as a number of peppercorns when swallowed together cause more heat than when taken singly; for the concentration of a number of warm objects increases their effective power. A big fire can consume much fuel, but a small one requires only a few combustibles—it is smothered by too much material.

While the fluids in birds of prey are dense and viscous, as is demonstrated by their great strength, they assume different aspects in the two sexes; for feminine nature is moister and colder than that of the male. In birds of prey the natural sexual coldness of the female tempers or abates her heat, and her moist tendency mitigates her thick and viscous humors, that are thus rendered more responsive to the action of heat. The final result is that the intense heat of the bird of prey and its thick and earthy humidity, when abated by the coldness and moisture of the female sex, operate to stimulate growth in the female body. In the male an opposite process is in operation. For, according to the philosophers, opposite causes bring about opposite effects.

In every species of rapacious bird, according to Pliny, there are fewer individuals than there are among the nonraptorials, comparing them species for species, and we believe that on the whole Pliny is correct. However, it is said that there are certain harmless species that consist entirely of a single male and a unique female, and that the phoenix belongs to such a species. This, however, we do not believe.

Birds of prey are fewer in number than harmless birds and are always land birds and never belong to either neutral species or to waterfowl. They are universally warmer and drier than the last two categories and have an aversion for water in two ways, one active, the other passive. Neither their structure nor their plumage fits them for aquatic pursuits; so they avoid the water. They are unable to stand up in it like long-legged cranes and herons, or to swim in it like web-footed geese, ducks, and coots. Their feathers, unadapted to aquatic life, would become wet and unfit for flying and still less competent for indulging in predatory acts. Also their talons, softened by (immersion in) water, would not be efficient in holding fast their captured quarry. Their fear of the water is the measure of their helplessness therein.

Certain birds resembling eagles, but smaller, and living on the cliffs near bodies of water, spy a fish in the water, drop upon it, draw it out, and feed upon it; hence they are called fish eagles.² Their structure and plumage are well adapted to an aquatic life; yet they cannot properly be called water birds, as they do not live in or upon aqueous bodies but always upon land.

We have defined the expression "birds of prey"; yet there are raptors not generally regarded as hunting-birds, such, for example, as the higher order of eagles, that, on account of their weight, cannot be held on the fist. If a large eagle were actually employed in ventry and mounted into the air, the falconer's other birds would be alarmed and from fright of the larger bird would refuse to do their duty.³

² *aguilae piscatrices*. Fish hawks (ospreys) have no feathered tarsi but a very rough tubercle on the lower aspect of each toe that enables them firmly to grasp the slippery quarry they pull out of the water.

³ Schöpffer notes that, though European falconers do not often train their large eagles as hunters, Oriental sportsmen do, using an artificial rest and arm sling to assist in bearing the weight of the heavy bird. The Em-

There are other small birds of prey, such as the merlin⁴ and hobby, that like the eagles mentioned above are used rarely and only for amusement. They are brought out as a novelty by men whose aim is to make a show of knowledge of falconry rather than to possess its reality.

The elements of teaching methods are about the same for both very large and very small species of hunters. Therefore we shall not specially discuss all of them. We shall confine ourselves to those birds most used by man that are easily carried and have no fear of each other and may be flown together. Moreover, for both use and pleasure, one gains more satisfaction in dealing with medium-sized birds of prey.

Men practice falconry for pleasure alone, for a material purpose, or with both objectives in view—to capture, for themselves or for others, some particular animal; for example, large, medium-sized, or small water and land birds, such as cranes, bustards, pheasants, partridge, and ducks or, now and then, such four-footed creatures as gazelles, deer, fawns, harts, foxes, hares, and rabbits. It stands to reason that one cannot hunt all these animals with the same kind of bird; consequently we must at least refer to every sort of bird employed in venery.

From the earliest times men have employed the following species of hunting birds, all of them regarded as noble falcons: gerfalcons, sakers, peregrines,⁵ true noble falcons,⁶ and lanner (desert) falcons. To this

peror's statement that the presence of an eagle would frighten the other hunting birds and act as a spoilsport is corroborated by the fact that Far Eastern falconers hunt with the eagle alone and rarely in the company of other birds.

⁴ *sineciliones et ubleti*—*Falco aesalon*, held in higher esteem elsewhere than in medieval Italy, and *Falco subuteo*.

⁵ *gentiles peregrini*.

⁶ *gentiles*, or, as the Emperor later calls them, *Falcones gentiles absolute*. Cf. chapter xxvii, pp. 124-27.

catalogue should be added certain hawks that are well known as hunting birds, the chicken hawk⁷ and the sparrow hawk.⁸ Every bird of prey utilized by the falconer in hunting should be classified as either a falcon or a hawk.⁹

Although many would apply the name *accipiter* only to the goshawks (asturs), we believe it is correct so to classify all birds of prey that hunt and seize their prey (asturs and sharp-shinned hawks) but do not strike down quarry as do the falcons, since the word *accipiter* is derived from the verb *accipio*, *accipis*, meaning "to take," "to receive." We shall speak of this further in our book on the chicken hawk (goshawk),¹⁰ where we shall compare it at great length with falcons.

CHAPTER III

OF THE BEHAVIOR OF BIRDS OF PREY DURING THE NESTING SEASON

The young of raptorial species are ousted from the nest as soon as they can fly. The parents also separate, seeking different hunting grounds, so that they are rarely seen in the company of one another. They may be discovered together, or one awaiting the other, only in the neighborhood of the eyrie. One may then notice the male, apparently expecting the female, perhaps for many days, or the latter looking for her mate; but occasionally they arrive together.¹

⁷ *Astur palumbarius* or European goshawk.

⁸ *Accipiter nisus*, similar to Cooper's hawk, only smaller.

⁹ Of course not in accord with the Linnaean division into vultures, falcons, and owls.

¹⁰ Probably never written, or else the manuscript was "lost."

¹ This short and insufficient chapter is merely a repetition of the material found at the end of chapter xxiii-D, of Book I, pp. 48-49.

CHAPTER IV

OF THE LOCALITIES CHOSEN BY
RAPTORES FOR THEIR
EYRIES

All birds of prey nest within the seventh, sixth, fifth, or fourth climatic zones and, we suspect, also in other regions. Some species prefer one zone, some another.

Out of respect for their size, strength, audacity, and swiftness, the gerfalcons shall be given first place in our treatise. Subsequently we shall discuss other species of falcons. Gerfalcons are fledged in or near the most distant parts of the seventh climatic zone, not infrequently on high cliffs, often in crannies, caves, and holes on mountainsides, either near to or distant from the seacoast; the farther the birthplace from the ocean the more beautiful and noble they are. Some of them are brooded on the high cliffs of the Hyperborean territory, particularly on a certain island lying between Norway and Greenland,¹ called in Teutonic speech Iceland (*Yslandia*). This name indicates that it is covered often by ice. These falcons are the best birds for hunting. They are called *Girofalco*, from *iero* (Greek ἱερός), "sacred"; hence *gerofalco* ("sacred falcon"); or from *gyri* (Greek κύριος) meaning "Lord," and so *girofalco*, i.e., "lord or chief of the falcons." They generally build their nests and sojourn in the seventh climatic zone, but never in the sixth, fifth, or fourth zone. They may occasionally breed as far north as the region between the seventh zone and the north pole.

The saker falcon² builds its eyrie in warmer latitudes than the gerfalcon (within or south of the seventh zone), often in Britain and Bulgaria. We have heard that since there are no suitable mountainous districts in those regions these falcons are obliged to nest in trees, but

¹ Gallandia.

² Hammer-Purgstall derives the word "saker" from the Arabic *saaker*.

it is my belief that it is in the nature of falcons to build their eyries on cliffs when available.

The peregrine falcon³ constructs its nest in the far north, beyond the seventh zone and near the coast, on islands and (like the gerfalcon) in lofty sites.

True noble falcons⁴ breed from the seventh climatic zone southward and choose the same environment as peregrine falcons. The latter are so called because of their (wandering) flights over the sea. Some persons believe true noble falcons and peregrines to be different species, and it is true that there are greater differences between those called true noble falcons and those entitled peregrines than there are between two individuals belonging to either class. The peregrines are said to moult later than true noble falcons and are larger and more attractive than the others; but we cannot discover any fundamental difference between them and believe them to be the same species and that both are noble falcons, closely allied. The difference in the moulting periods depends upon the country whence they come, as do also their size and beauty. Because of the extreme cold of their birthplace they are hatched late and, therefore, moult late. But variations in color, habits, and place of origin do not necessarily cause either men or other animals to belong to different species.

Lanner falcons⁵ breed in all the climates and lands mentioned above, as do other falcons. They have arboreal nests in those countries where the saker falcon breeds.

All falcons endeavor to build lofty nests

³ *geniles peregrini*.

⁴ *falcones absolute geniles*.

⁵ Gilbert Blaine (*Falconry*, 1936, p. 21) says: "The lanner falcon, found in parts of Southern Europe and throughout Africa, is of about the same size and proportions as the peregrine, but less powerfully armed. . . . Both saker and lanner are termed 'desert falcons'; in addition to birds they prey upon small mammals and reptiles."

in suitable localities, where they can support themselves and their young ones by using their powers of flight to catch other birds and where they will not be disturbed either by human beings, other rapacious birds, or marauding beasts.

CHAPTER V

OF HAWKS (ACCIPITRES)

Goshawks¹ and the sharp-shinned hawks² (*austures et nisi*) breed and build their nests in forest trees in all climatic zones. The more daring they are, the lower they build their nests, because, as commonly believed, the large birds they capture are more easily carried to the eyrie when it is built near the ground.

They live, moreover, in valleys; for quarry caught on high ground can be more easily transported to a lower level than to a still loftier one. Prey caught on low ground is sometimes dragged with difficulty to a position above the eyrie and then easily carried in downward flight to the nest. Sometimes these hawks construct in summer an eyrie low down in a valley near a body of water, since here [harmless] birds often gather to drink and bathe. As a result of this arrangement the hawks have their prey close at hand and it is easy to carry it to the nest. They also enjoy a cool and humid resort protected from the fierce rays of the sun. As these birds are of a warm nature, they frequent the cooler tops of the trees.

As a rule, all rapacious birds born in the seventh climatic zone and still farther north are larger, stronger, more fearless, more beautiful, and swifter than southern species. This is due to the continued cold that tempers the hawk's internal heat, thereby increasing the humidity of the body and adding to the size of the bird's members, as we have already explained in a previous chapter.³ They are stronger because the icy wind that prevails

in the far north closes the bird's pores and prevents the evaporation of her internal warmth; hence her energy is reinforced and her blood and other juices are purified. In warm countries the warm humors are exhaled and a decrease of vitality follows. Courage increases in cold countries with a sense of greater strength and the possession of warmer and purer blood. On account of the checking of exhalations the birds grow stronger and the bodily fluids become warmer. They have, also, in relation to their bodies, a large and warm heart. All these elements combine to promote courage. And courage, added to acute hunger, incites them to make a bold attack on other birds. The proof of these statements is that hawks of northern lineage have a large heart, covered by a double sclerotic coat.⁴ We ourselves bear witness to their great bravery.

We find these birds in fine form because their humors are so perfectly mingled and balanced that all parts of the body are uniformly developed. For the same reason their members are more attractive than those of other birds because they are formed by the fluids of their own body and its heat that also create their robust, red color. It follows from these facts that they must be exceedingly active on the wing, and those individuals of the species born nearest the seventh zone most nearly attain perfection in appearance and performance.

CHAPTER VI

OF THE OVULATION OF BIRDS OF PREY

The time that elapses between conception and egg-laying in rapacious birds is unknown; we are ignorant of the precise date of actual fertilization of the ovum.

¹ *Astur palumbarius* Bechst.

² *Accipiter nisus*.

³ Book II, chapter ii, p. 82.

⁴ *pericardium duos corios*.



PLATE 63.—Hawk in plumage of advanced age, Reichsfalkenhof, Germany. Courtesy of owner. (Photo by Fischer)

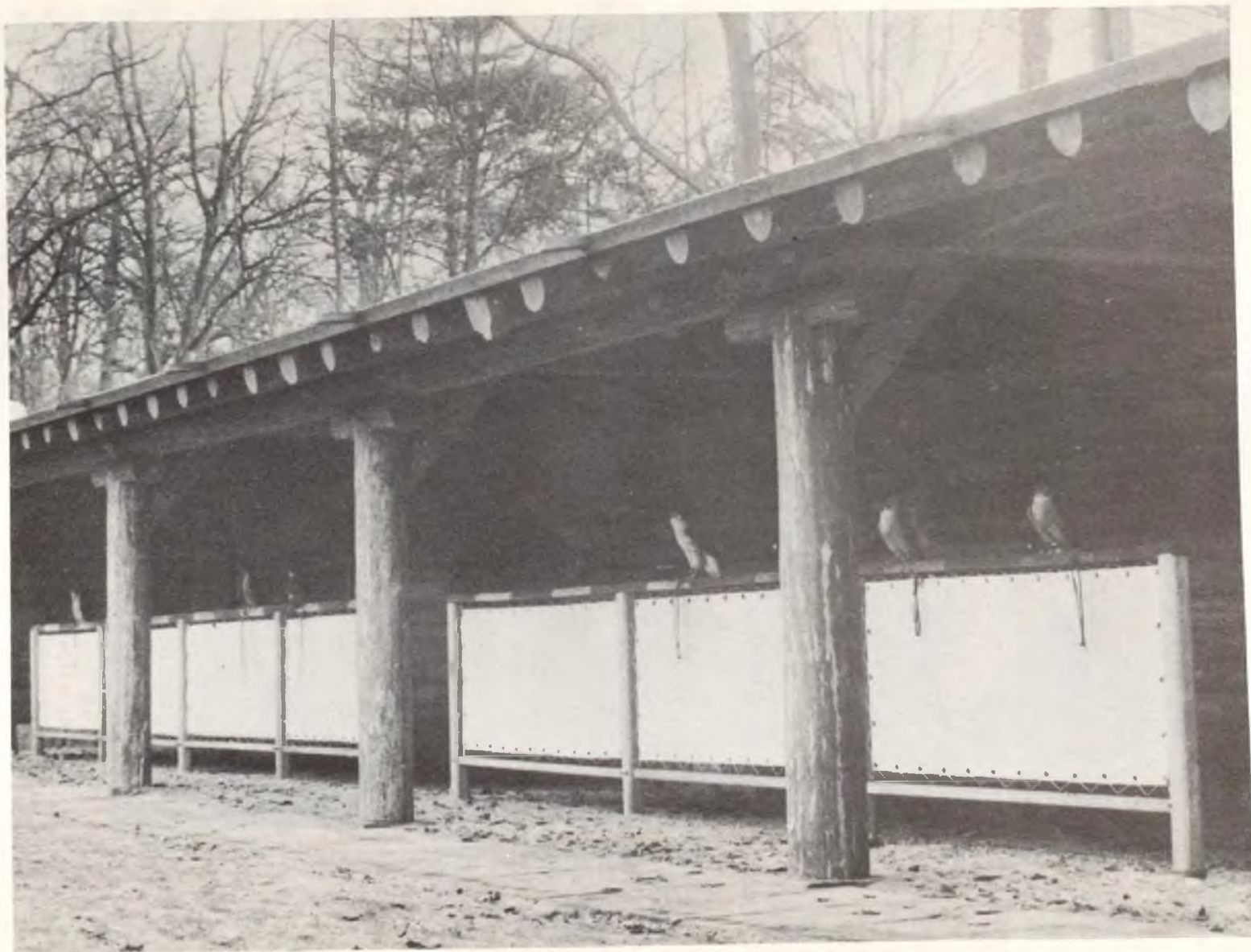

PLATE 64.—Section of the Outdoor Refuge, Reichsfalkenhof, Germany. (Photo by Fischer)



PLATE 65.—Hawk on the high perch. (Photograph from the Japanese Imperial Falconhouse, 1936)



PLATE 66.—Falcon and falconer from the Imperial
Japanese Falconhouse, 1936

Birds of prey lay three, four, even five eggs, from which, however, not always the same number of young are hatched; some of the eggs in a clutch may be sterile, addled by thunderstorms, or spoiled by some other evil agent.

CHAPTER VII

OF THE BROODING SEASON

We can say very little that is definite about the brooding period of birds of prey because so many of them nest in distant localities from which we can secure little information. In my experience eggs are brooded always less than forty days before the appearance of the nestlings.

CHAPTER VIII

OF THE SMALL FEATHERS, DOWN, AND FLIGHT FEATHERS OF BIRDS OF PREY

Birds of prey are born with a certain amount of covering which is neither hair nor down, although it resembles both. It serves as a protection from cold. Next to appear are the true woolly feathers, or down. These are slender and soft, but thick and long; they act as a more efficient envelope and better defense than the earlier coverlet, that falls out on the appearance of the true down feathers. Finally, the contour feathers appear; but they develop slowly because they are more compact and because all birds of prey have longer pinions in proportion to their size. In about two months they are fully grown. These feathers are moulted once only during the first year—prior to the moult hawks are called *saurae*, or “the unmoulted”—and not twice like most nonraptorial. The number of flight feathers in the tail and wings of raptors does not vary—unlike those of non-predatory birds.

CHAPTER IX

OF THE FEEDING OF RAPTORIAL FLEDGLINGS BY THEIR PARENTS¹

The mother bird feeds her brood until they can fly and while they are too young and too weak to tear their animal food in pieces. She visits the eyrie and regurgitates from her mouth the flesh of birds or, failing this, parts of mammals that she is able to secure. These viands have been previously shredded, warmed in her crop (*gorgia*), reduced to a pulp, and partly digested. The young ones receive this pabulum in suitable quantities and at proper times—in early morning and in the evening. As soon as their mandibles and other organs have developed sufficiently, the maternal parent no longer feeds the young birds with the contents of her crop but brings to them in her talons birds stripped of their feathers, which she places before them. At times she deplumes the avian prey in their presence. If this food is not available, the fledglings are fed with other kinds of meat.

CHAPTER X

HOW THE FEMALE FALCON TRAINS HER OFFSPRING TO HUNT²

When her young ones have grown still larger and stronger, the female parent brings a dead bird to the nest and shows them how she plucks and eats it; and this she repeats many times. When these lessons are apparently learned she presents the fledglings with a live bird partly deplumed so that it cannot fly away. She liberates this quarry and encourages the youngsters to follow it. When one of them has pounced on it, she summons the others so that they too may join in the

¹ See also Book I, chapter xxiii-H, pp. 53-56, and Book II, chapter xxxiii, pp. 130-31.

² The chapter is a repetition of a portion of Book I, chapter xxiii-H, p. 56.

feast. Should the prey fly off, she recaptures it and releases it in their presence; and when one of the young birds has successfully imitated the parent in killing and eating it, she prevents the others from joining in, so that the first bird may not be interfered with. In this way fledglings learn to fly and to capture their prey.

CHAPTER XI

HOW AND WHY FALCONS EXPEL THEIR YOUNG FROM THE EYRIE

After fledglings have learned to fly and to capture their own prey the mother bird drives them from the eyrie and out of the locality of their common nest. Were the young ones to hunt with the parents, all the birds they require for food would soon leave the neighborhood and they would find little to eat. Again, when the parents caught anything one or other of the youngsters would probably lay claim to it. So she drives them away and in addition separates the whole family, each one to fend for himself in new territory, where (with other prey) they hunt field crickets, locusts, caterpillars, and beetles. In the absence of locusts and the like, which disappear with the first cold weather, they capture such small birds and mammals as they can find.¹

CHAPTER XII

OF THE RESIDENCE CHOSEN BY YOUNG BIRDS WHILE IN THE LAND OF THEIR BIRTH

Raptorials that have abandoned the nest and the region of the eyrie in which they were born always choose a lofty, prominent, and isolated outlook, on a tree, cliff, or mound which offers an unobstructed view of the

¹ Cf. Book I, chapter xxiii-H, p. 54.

neighborhood and from which quarry can easily be spied. This post they retain and return to for rest until they are forced to leave the neighborhood.¹

CHAPTER XIII

WHEN BIRDS OF PREY GO FORTH TO HUNT FOR FOOD

Birds of prey leave early in the day to seize their quarry; after they have fed they return to their usual roosting place. When the meal which they have taken in the early morning is not enough to satisfy them until the following day (either because the quarry was not sufficient or because they were compelled to abandon the booty before finishing their repast), they go out to seek a second meal after three o'clock.²

At times falcons have been seen hunting at night—chiefly on moonlit nights—probably because they were unable to secure their prey in the daytime. This rare behavior is unnatural and occurs only through urgent necessity.

CHAPTER XIV

OF THE MIGRATION OF BIRDS OF PREY

Predatory birds are, as a rule, solitary in migration, fearful lest other raptores carry off their food. Indeed, they avoid any associates, whether of their own kind or not; since it is in the nature of birds of prey to steal the food of other rapacious birds. Raptorial migration is governed not so much by climatic conditions (since birds of prey stand cold weather very well) as by the necessity for following migratory flocks of nonpredatory birds on whom they feed.

¹ When they migrate, or for some other imperative cause.

² *post nonam.*

CHAPTER XV

OF THE SEASON OF THE YEAR CHOSEN
BY PREDATORY BIRDS FOR
MIGRATION

Birds of prey leave in the autumn with other migrating birds when the weather is favorable, whether that be at night or in the daytime. They immediately forsake their food and forego their sleep if the wind blows in the right quarter. We have ourselves observed that they abandon food thrown to them that they have been preparing for consumption just as soon as a breeze favorable for their journey springs up.

[*Addition by King Manfred:*¹

The necessity which impels falcons to hunt at night is the following: when the time for their migrations approaches they become restless and hasten on their way lest the clement weather that favors their journey become disturbed and unfavorable; they go without food for several days rather than lose time. Thus it sometimes happens that they take no heed of meals while traveling by day, but should it happen to be the period of the full moon enabling the falcons to see, they hunt for a bird and, having caught it, they take advantage of the opportunity for a meal.]

CHAPTER XVI

OF THE LOCALITIES FROM AND TO
WHICH BIRDS OF PREY MIGRATE

To these questions we shall not devote a special chapter, as they have been fully discussed elsewhere in this work, and what applies in this instance to birds in general is applicable to birds of prey in particular.²

¹ From the Vatican Codex, fol. 52, col. 2.

² Cf. Book I, chapters xxii and xxiii, p. 40.

³ Book I, chapter xxiii-A, pp. 42-43.

CHAPTER XVII

OF THE RETURN OF BIRDS OF PREY
TO THEIR EYRIES, AND OF THE
CONDITIONS UNDER WHICH
THE JOURNEY IS MADE

Predatory birds return one by one in the springtime, when the winds are gentle and with the return of their avian food. They appear at the same time as nonrapacious species, who also choose clement weather. Then follow pairing and the procreation of their kind for the preservation of the species, as is described in the chapter on the return of birds in general.³ Returning raptors are found to be most numerous in cold countries—in the seventh climatic zone and farther north—especially in the spring and summer, because they are of a very warm habit and prefer a cool atmosphere. This is their nesting season, and here they can catch those birds that are their natural food and that are also more plentiful in northern latitudes at these seasons. Here, too, lofty trees abound as well as forests and high cliffs that afford a safe shelter for their nests. Forests and lofty trees attract hawks, cliffs the falcons. There they construct their nests and find wide open spaces where they can hunt to their heart's content, with no interference from other birds. In the autumn and winter they seek warmer localities, in which they find also nonpredatory, food-providing species.

CHAPTER XVIII

HOW TO RECOGNIZE FALCONS BY
THEIR FORM AND PLUMAGE,
AND HOW TO SELECT
THE BEST

[*By King Manfred:*

As we repeatedly read over this book, to gather from it the fruit of knowledge and to remove all scribal errors, we discovered after reading the Preface that our Imperial Father had placed (next in order) a chapter,

among others, on how to capture falcons. We also found between that chapter and the Preface some blank leaves, which led us to the conclusion that some chapters were missing. Later we discovered, on looking over the notebooks and memoranda of this book (because we saw that certain passages needed correction), inscribed on loose sheets, a chapter entitled "On the Plumage of Falcons." In it were detailed the differences between species of falcons as shown by their build and feathers. Remembering the doubt we had entertained when we reached the chapter referred to which followed the Preface and where we felt something was missing owing to the blank pages, it seemed to us that the chapter¹ on form and plumage belonged there, because the directions telling how to recognize falcons ought to precede an account of how to procure them, else the reader might fail to discover what he was seeking through inability to recognize it. Only by mere chance (and not by authentic knowledge) could the searcher escape disappointment and secure a bird of one species when he hoped for a hunting bird of a different kind. We thought, therefore, that the passage on how to recognize various falcons by means of their plumage and structure should be inserted before that on how to secure them.]

CHAPTER XIX OF THE GERFALCON²

The best gerfalcons may be known by the following characters: the upper portion of the head is level and not prominent, the posterior segment is full and broad; the forehead above

¹ King Manfred uses the word *capitulum*, but the passage includes chapters xix-xxx. He does not tell us where he found chapters i-xvii, which are not in the Bologna text (nor in the text sent Manfred by Frederick), since the King tells us that the chapter on how to secure falcons followed the Preface. Most of this material is found in the chapters in the Bologna text of Book I that are missing from the Vatican Codex.

the eyes is wide, the superciliary shield is prominent, and the eyes are deep-set; the nostrils are broad, with wide openings; the beak is thick, curved, and hard. The neck toward the head is slender; but at the shoulders it is quite thick. The space between the shoulders equals the width of the back, and the intermediate wing joints (called by some the wing propellers) are directed toward the head when the wings are not spread wide, i.e., pointed upward and not downward. The body is uniformly proportioned, shapely, and tapering toward the tail, like the figure geometers call a pyramid. Both wings fold together on the back in such a manner that they neither project nor hang down. In this position one is laid over the other in the form of a cross. Not only the flight feathers but the contour feathers, both large and small, in the wing (i.e., the upper and under wing coverts) are hard and wide. The more the coverts protect the quills beneath them and the farther toward the extremities of the latter they extend, the more efficient they are. All the tail feathers when at rest are united beneath the two middle rudder quills and are folded together.

The crop region (*locus gorgiae*) is plump and broad; after several meals the crop becomes round but not much distended; the breast is elevated in front, and is thick and fleshy; the iliac bones are wide. The shinbones are short and strong; the ball of the foot (*palma*) is large and ample; the toes (*digiti*) are long, narrow, rough, scabrous, and widely separated; the claws are thin, incurved, and needle-pointed.

The feathers called the crissal feathers² (under tail-coverts), beneath the large rudder feathers of the tail, are well developed and reach nearly to the end of the tail proper.

² This word is of doubtful origin. Newton believes the name to be immediately derived from Low Latin *gyrofalco* (from *gyrare*, "to circle") and not from the hybrid *hierofalco*.

³ *bracalae*, breech feathers.

They fill, during flight, the spaces between the large tail feathers. The down feathers on the hip bones (*plumae coxarum*) above the knees are long and reach to the caudal area.

On the whole, all the contour feathers, large and small, are neither ruffled nor tousled, but lie close to the body and rest smoothly against each other.

The body of the gerfalcon is larger and heavier than that of other falcons.

CHAPTER XX

OF THE PLUMAGE OF GERFALCONS

The feathers of gerfalcons are some of them gray, some of them white, while others are whitish—particularly on the breast. Others, again, show a mixture of white and gray which many call hemp-colored. The white tints on the breast are the most brilliant; those on the back during the first year are partly reddish, partly rust-colored. After moulting, the red feathers assume a black shade, the white of the plumage becomes more marked, and the mandibles and claws of the white gerfalcon, more than those of other birds of the genus, have a decided iridescence. Gray gerfalcons display, before moulting, feathers of a variety of color; some of them are dark, or blackish, others rust-colored. These latter are of two types: they may have spots all over the back and tail, or they may be entirely free of such markings. Some are decidedly speckled, some less so. Very dark specimens may turn reddish, dark and gray after the moult; if they are not of the spotted variety the coloration may change to bright gray and red; if bespeckled, hemp-colored. Bright gray birds after their moult become either whiter or grayer.

¹ Schlegel states that Belon was the first naturalist to separate (in 1555) the sakers from the lanners.

² This small chapter is evidently not complete and is a mere fragment of what the Emperor would have written had he ever entirely completed his great work.

CHAPTER XXI

OF THE FINEST PLUMAGE IN GERFALCONS

It is difficult to decide what colors are most to be desired in gerfalcons, as there exist fine specimens with all shades. In our experience the rare white varieties from remote regions are the best. After them hemp-colored individuals are most valued. The nearer the color of a bird approaches these, the more highly it is prized.

CHAPTER XXII

OF THE SAKER FALCON¹

The saker falcon (*Falco sacer*) ranks next in size to the gerfalcon, although it is not quite as large. The head is large and round; but the beak is relatively short, the body is proportionately more slender and longer, the wings and tail are longer, the breast is less fleshy and thick than in the gerfalcon, and the toes (*digiti pedum*) are shorter.

The beautiful plumage and the attractive appearance of their external organs are not, as in the gerfalcons, always indicative of their true value. Sometimes one finds well-built and fine-looking saker falcons that are neither swift nor otherwise praiseworthy; while, on the contrary, some birds in bad form and of inferior plumage may prove not only to be swift on the wing but to possess other useful qualities. One should judge these birds by other attributes.

CHAPTER XXIII

OF THE PLUMAGE OF SAKER FALCONS²

The feathers of the unmoulted saker show various colors, brown shading into black, reddish, or golden yellow. Unlike many other birds, after the moult their plumage remains little changed.

CHAPTER XXIV

OF PEREGRINE FALCONS

Peregrines are smaller falcons than the sakers; but their build and superior hunting qualities allow them to rank with the best of the gerfalcons, whom they resemble in having a thick and hooked beak, broad nostrils, similar smooth crown (that is neither elevated nor protuberant), round eyes, overhanging eyebrows, prominent occiput, and a short neck that is slender at the head and thick near the shoulders. Between the shoulders the neck is prominent.

Between the breast and throat is a deep, wide depression for the crop, the hollow organ that receives and partly prepares the food before it reaches the stomach. Even after a heavy meal the crop is never so distended that it overrides the margins of the cavity that contains it. The breast is prominent, ample, and fleshy.

The "breeches" (*bracalae*), long and well-developed feathers, hang down behind the knees under the tail; the shinbones are thick and short; the foot is broad, with the toes widely separated, long, and narrow; the claws are long.

The distance from one shoulder to the other equals the width of the back. The articulations for the third wing joint, where the large primaries begin and which, when the wing is closed, lie higher than the inner segments of the wing, are drawn upward in the direction of the head. The wings are raised over the back and do not slope downward but are crossed over the renal region. The feathers of the back are wide and have round ends. The large flight feathers (*pennae*) of the wing, including those under cover [the primaries—*cultellos*] as well as the exposed quills [secondaries, or *vani*] are smooth, not curled, and are wide and firm. All flight and contour feathers are everywhere flat, smooth, and closely applied to the body. The large

feathers of the tail fold under the two central rectrices.

Peregrine falcons that have not yet moulted are some of them entirely brown, with no marginal shading on the feathers. Others are brown touched more or less with red and have red marginal bars. Still others may be paler than the average and show bright marginal bands. Young birds of a reddish coloration may be either of a uniform tint without marginal bands on the back or on the edges of the tail feathers, or the color may shade into brown accompanied by brownish bars, or they may appear as dun color with brighter margins. Those of a fawn color may be of a solid tint without barred feathers on the back and tail; or they may shade off into rust color with the corresponding barring, or into white, when the stripes on the feathers are also white.

The spots on the fore parts of these falcons, scattered from the throat over the whole breast to the ovarian region, may be either all large or all small markings, or they may be of mixed sizes, large and small; generally they are small from the throat to the merrythought¹ and large farther down.

Some peregrines have speckled feathers on the back, wings, and tail; this is not the case in others. These spots of color may be reddish, whitish, round or elongated, large or small, sparse or numerous.

Some of the brown race of peregrines have whitish, marginated plumules and flight feathers on the back, wings, and tail; in others the edges are reddish. One notices that these markings vary in breadth, particularly at the marginal extremity of the feathers. Reddish and fawn-colored peregrines may also be distinguished as barred, spotted, or speckled, in the same way as the brown peregrines.

Let us now deal with the brown "wanderer," that is, with the dark brown species that borders on the red variety and which

¹ *furca pectoris*.

some claim does not belong to the true peregrines.² This opinion is probably due to their rarity and because they are black-brown and are quite unlike the reddish and tawny varieties. We are opposed to this view of the matter because the deep-brown race is one of the best and most beautiful of the peregrines, and especially since they have the same physique and plumage we have already described as belonging to typical noble peregrines. In this connection it may be remarked that we designate as dark-brown or reddish-brown only those birds in whom the red and brown are so intimately blended that they can be called neither brown nor a true red. The best of these dark peregrines have a crown of red feathers on the head forming a circlet about it, and the leathery skin between the horny mandible and the nearest feathers of the forehead, around the nostrils (i.e., cere), usually has a greenish hue.³ The feathers of the sub-orbital region are reddish and those behind them about the ear (should be) tawny, tending to a ruddy shade. The broad, red-brown, dorsal feathers have a ruddy iridescence, and the broader the red markings at their extremities the more attractive they are. They should be without spots. The flight feathers are brown and are bordered in the manner described. The tail feathers—colored, margined, and devoid of spots, like those on the back—are most beautiful when the terminal bands are broad, especially when they exhibit a play of reddish coloration. It is, however, to be understood that this elegance is due to the barring, as the marginal red in the tail feathers is less marked than that of the dorsal plumage.

In falcons having barred feathers, the marginal bars of the tail are whiter and paler than those of the dorsal region. The reason for this peculiar edging is that the whiter bars

² *gentiles peregrini*.

³ The Emperor probably referred to the Barbary falcon. See the section below (p. 531) entitled "Annotated Roster of Birds Familiar to Frederick II."

are farther from the heart, the source of natural heat; just as the outside leaves of a tree, suffering from diminished internal warmth and lack of nutriment, seem less green, and the distal ends of human hair become gray. Added to this cause are the discoloration and repeated abrasions of the tail feathers, that often touch the ground and other objects, to which form of injury the dorsal plumage is less exposed.

The black spots below the chin are large but not very long; they are of the same size as and similar in color to those around the throat and over the whole breast. The down feathers under the wings have a reddish reflection, while the centers of those over the hips are brown with a shimmer of red in it. Their margins on either side are rounded and fawn-colored. The feathers of the thigh also have spots of the same color as those on the breast. They are neither fine nor sharp, and are arranged in regular rows, their number and coloration being constant in relation to each other.

The coloring of the talons in this falcon harmonizes with the plumage; i.e., the browner the peregrine the greener are her "feet,"⁴ and the redder she is the more citron yellow her feet become; while if the bird exhibits tawny shades, the talons have a greenish-white shade corresponding to the general coloration.⁵ However, the color of the talons always tallies with that of the cere. There are cases, however, when neither of them corresponds in color with the plumage and these birds are not as desirable as those that have harmonious tints. When, finally, the cere has the proper coloring but the talons are, in that respect, aberrant, it is not so great a drawback as when both of them are against the rule.

⁴ Falconer's slang.

⁵ The chief factor in the coloring of the peregrine and its talons is age, after which rank innate individual variations.

CHAPTER XXV

OF BROWN, REDDISH, AND FAWN-COLORED PEREGRINE FALCONS

Those dark-colored peregrines that most closely preserve the plumage and form just described must be considered as of a superior, more exclusive, and more beautiful class. We call reddish-brown those peregrines that have a basic tone of brown and are consequently more brown than red; and those that we call brownish-red are more red on the back and on the contour and flight feathers than are the former. The more the color of the plumage is in accord with that of the cere and talons of peregrines, the higher the hope one may entertain of their superior hunting performances.

CHAPTER XXVI

OF UNDESIRABLE PLUMAGE IN PEREGRINE FALCONS

Peregrine falcons may because of their coloration promise little (as to their future usefulness), especially if they have a plumage that is pale with bluish specks in it. This is the case, also, when the feathers have only pale or no marginal bars, or if the tail is gray and the coloration of the back is dissimilar. This rule holds good also if the spots on the breast are small and the feathers of the "breeches" have their central maculae so inconspicuous that the coloring of the background is barely obscured. It also applies when the plumules of certain peregrines are bright-bluish beneath the wings and the coxal feathers exhibit neither orderly arrangement nor similarity of color and size but are all mixed. Such individuals have even less chance of being numbered among the elect if they also have bright yellow cere and feet.

It occasionally happens that the bodily form of a young peregrine falcon is so unde-

veloped that everyone holds it to be of small value but after moulting it develops a vigorous growth; the pinions of the wings and the feathers of the tail may become stouter, more compact, and stiffer than before the moult, and in front they may turn white and on the back beige.

Some falcons that do not possess the finest feathers have diagonal markings on the dorsal region and on the tail that are brownish and more or less of that color both before and after moulting. If this coloration was pale before, it becomes whiter after the moult; if brown, not so white. This is true also of the longitudinal spots on the throat after moulting that are more delicate than before the feathers were shed. Then the spots from the throat downward, that before the moult were longitudinal, always appear after it as transverse bands. These markings, like those on the throat, assume a darker brown than they had before the moult. The cere and talons of those peregrines that moult during their wild state take on a saffron-yellow shade.¹

CHAPTER XXVII

OF THE TRUE (GENTLE OR) NOBLE FALCONS

Like peregrine falcons, true gentle falcons possess before moulting three kinds of plumage, and those that most closely resemble the best peregrines in form and plumage are the most desirable.

Although we have stated that true gentle falcons are of the same species as the peregrine falcon,² the former differ somewhat in having a smaller body, a more spherical and smaller head, a shorter beak, and less powerful talons than the latter; also in true gentle

¹ Such a falcon is called a "haggard," i.e., one caught after she has acquired her adult plumage.

² See also Book II, chapter iv, p. 111.

la plus convenable partie
 contre le vent de quel que
 part que le vent vaigne
 en ceste maniere cest a sa
 voir quil oppose son dos
 au vent et de la faucons

ia par ces tours
 devant le piez du faucon
 ruer ce le vent ne vient
 a lui par devant le dos il
 puidt estre recouvert a la nuit
 ainsi com il estoit recouvert
 dou debat qui est fait du
 ne mai vers la terre car p
 ceste maniere il san plus
 legierement rancez a ruer
 li oisel aient touz jours du
 sage desier et de seoir contre
 le vent si pavoille du vent

Libans est une desau
 tes qui vaut mie o
 tre les effrois et les debas
 dou faucon pour lor adon
 nair et a coustumer de de
 moier avec home et pour
 ce il est adon du baig des
 faucons com li faucon a li
 et li autre oisel de proie son

ent de plus seche nature q
 li autre oisel non de proie
 il ont a coustumer de lor baig
 nuer qnt il sont par lor et
 fauconage pour ce al nestet
 baigne il encourroit plu
 sours grans malades par
 lor secheite si onoul dirons
 on craint des maladies et po
 ce de necessite nous lor devos
 offrir baig nō mie soulement
 dans leurs gles adon nair
 li bams sera fait en ceste ma
 niere on prendra une tigne
 de bois ou de fer de la que li
 rondesse soit de .ij. piez dou
 moins selonc la largesse de li
 et soit de une hauteur tant q
 le adon nair aigue jusques a
 l'ouverture dou faucon ou plus
 ou moins selonc la hauteur
 des jambes et des cuisses
 dou faucon ou de baig nuer
 li aigue doit estre froide de
 re et douce que doit avoir
 pour de maniere qualiter
 et li dussiaus nait nulle de
 ruer. p ce q celle vertitez



PLATE 67.—The French illuminator's idea of the falcon's mews and bath (Bibliothèque Nationale MS. Fr. 12400, folio 158). Compare with Plate 134 (p. 422)



PLATE 68.—Falconers leaving and entering the mews. Note the style of architecture and the dress of the southern Italian attendants.

falcons the corresponding colors are not so bright and beautiful as they are in peregrines.³

The fine feathers and the attractive forms of the best peregrine falcons are more closely approached by all peregrines than by the best of the true gentle race; in some instances the former reach avian perfection, but the latter never do. There is so little difference, however, between these two varieties in both plumage and bodily form that it is not easy to draw such a distinct line between them that an inexperienced man can differentiate one from another; and only long practice can prevent a falconer from mistaking the one for the other. On the other hand, the divergences in their accomplishments are so manifold and so apparent when in action that one cannot be mistaken for the other, as will be made clear in that portion of our work devoted to the performance of these birds.

When true gentle falcons have shed their first feathers, the flight feathers closely resemble those of the peregrine falcon; but they are more profusely speckled on the back and tail and for that reason are not so beautiful.

CHAPTER XXVIII OF LANNER FALCONS

Lanner falcons are smaller than true noble falcons and they have in comparison to their bodies a thicker head and throat than other falcons. They are long, slim, and not fleshy; their talons are small and their toes thick, short, and golden yellow. Some of them are brown, some reddish; mostly they are pale in color and speckled on the back. However, one cannot judge these falcons by their form or by their feathers alone; we regard as most beautiful those that in all respects resemble the saker falcons.

Lanners, after their moult, have a white

³ The Emperor (or his scribe) makes several rather vague and confusing statements in this chapter when he compares these two "species" of falcons.

breast and beneath the chin and on the throat small round black spots that assume a transverse arrangement below and on the flanks and back.

Other specimens are found of a gray color, interspersed with large black-and-white horizontal markings. These, after moulting, become fainter. Such birds are neither as courageous nor as swift as the others.

We have¹ described the raptores in general and the various species of falcons most used by falconers. We must now consider the short-winged hawks (among them the goshawk and the sharp-shinned hawk)² that are used in hawking. However, as we plan to devote a special book to them,³ we shall omit them for the present, and discuss the differences between nestlings and branchers.⁴

CHAPTER XXIX

ON SPARROW HAWKS¹

Sparrow hawks are smaller than other birds of prey employed by the falconer. They resemble the goshawks and, although the latter belong to a different species, those sparrow hawks that have feathers and bodily build corresponding most closely to the goshawk are the finest. Their markings are, however, always horizontal, and the tail is banded. A sparrow hawk with spots on the tail such as one sees on

¹ Chapter xxix should begin here.

² The small European sharp-shinned hawk (*Accipiter nisus*), resembling Cooper's hawk, only smaller.

³ *Specialem tractatum*. The author apparently intended this to be an additional book of the *De Arte Venandi*, in which he refers to each book as a *tractatus*. Cf. Book II, chapter v, p. 112.

⁴ Chapter xxx, p. 128.

¹ This chapter heading reads in the Vatican Codex (fol. 57): *Dicto de forma et plumagio convenienti austerum saurorum et eorum qui mutati sunt, dicendum est de sperverius*. The description of the goshawk is missing and, taken in conjunction with the last paragraph of the preceding chapter, it is clear that it was not Frederick's intention to include it at this point.

goshawks is held to be most beautiful. Sparrow hawks have barred feathers in front both before and after moulting and these birds are considered most attractive when they resemble goshawks that have already moulted.²

It should not be forgotten that in both goshawks and sparrow hawks the pupil, previously small, is enlarged when their gaze is firmly fixed on an object. Occasionally we have seen hawks with large pupils, like those of falcons, but never falcons with eyes like goshawks and sparrow hawks.³

CHAPTER XXX

OF THE DIFFERENCES BETWEEN NESTLINGS AND BRANCHERS¹

There are well-marked differences between nestlings and the so-called branchers. The former can rarely be raised artificially without stunting the growth of their bodies. Even when no decided defect of this kind results, their feathers are not as compact, clean, and fresh in appearance as those of the branchers; at least they are seldom so well developed, and one does not find among branchers those dwarfed or crippled members occasionally noticed in nestlings; indeed, they do not have the normal growth of the branchers. The reason for this is that in the nest the young are fed

² Young as well as mature sparrow hawks are horizontally barred on their under parts, but the former also show longitudinal bars. Fledglings have their entire inferior parts thus marked, afterward to assume horizontal stripes, so that young hawks are sometimes mistaken for another species.

³ There is no evidence to prove that the Emperor was aware that the avian iris, unlike the human organ, is controlled by voluntary muscles and that to a large extent its expansion and contraction (the size of the pupil) are dominated by the bird's will.

¹ Nestlings (or *eyases*, *nidasi*) are those falcons that have been taken from their eyrie and raised artificially. A brancher (*ramagus*) is a falcon that has abandoned the eyrie of its own accord but continues to roost on branches of trees near by, and has been caught for training.

by the old birds with the food most suited to them and at the proper time, which is a difficult matter for the falconer; moreover, in their own eyrie they breathe purer air (than in the mews). Consequently the coloring of the cere and of the talons is paler in nestlings than in branchers; also, the claws and mandibles of the former are not as smooth, bright, and sharp as those of the branchers. The latter do not, as a rule, become such screechers (*clamorosi*) as do nestlings, who are prone to scream, at the same time keeping their mouths wide open.

When it is fed, the nestling ruffles its feathers and holds the food tight with beak and claws. If the keeper reaches out his hand toward them, some birds fight for their food; hence among us they are vulgarly called "greedy-guts" (*grimiosi*).²

The earlier the young birds are taken from the nest the more marked are these peculiarities; the later they are removed the more they resemble branchers.

Differences in their behavior during flight will be described later, in the appropriate place.³

CHAPTER XXXI¹

ON THE METHODS OF CAPTURING FALCONS, AND OF THEIR CARE AND FEEDING²

Falcons may be secured in several ways. One may simply lift them out of the nest or catch them with various devices in the neighborhood of the eyrie as soon as they have left it. In the autumn³ they can also be caught

² Old French: *grigneus*, Bibliothèque Nationale, MS. Fr. 12400, fol. 94^v.

³ In Books IV and V.

¹ With this chapter, the text of the Bologna Codex is resumed.

² The Vatican Codex title reads, "Methods of Capturing Nestlings."

³ The Vatican text reads *tempore veris*, an obvious error that does not occur in the Bologna manuscript.

while they are moving from one resort to another, fleeing from the cold. There is also a fourth scheme, one for capturing birds in the regions where they pass the winter. A fifth plan (applicable to all birds) is to catch them as they return in the spring to the nest which they had deserted on account of the frosts of winter. Among those that migrate, as well as among those that return to the nest, unmoulted birds⁴ may be caught along with some that have moulted once or several times.

Nestlings may be secured in several ways. First, one may remove the eggs from the nest and have them incubated by a tame, domestic fowl; but this plan is not to be recommended, as few of these nestlings prove to be of any practical value. Second, they may be taken from the nest before they develop true feathers or pinions but have only down feathers as a protection against cold. Third, they may be removed when the down has begun to fall and the feathers are not yet fully grown, when there is a growth of both down and feathers. Finally, there is a fourth plan, which is to wait until both flight and contour feathers appear but not until the bird entirely abandons the nest to fly and hunt.

Nestlings taken very young and small are poorly prepared for their future career. It is far wiser to leave them in the nest as long as possible, because the longer they are fed by their parents the better and stronger will be their limbs and pinions and they are less likely to become screechers or gapers. Remember that no one can feed them like the parent bird, who always supplies them with wholesome food in proper quantities and at the right time so that they may have healthy feathers and a well-built frame. If they are removed from the eyrie when they are too small, they are dependent for their food upon man, who does not know with certainty the amount nor the sort of food they require; and there is always the chance that something unexpected

⁴ Birds still in their first year.

may happen to them, or that some part of the body may receive an incurable injury. Even when none of these accidents occur and the youngsters appear to be in good condition (which is seldom the case), they are not really as strong nor are their flight feathers as sound as those of birds that have had the care of their parents in their own eyrie.

CHAPTER XXXII

HOW TO REACH THE EYRIE

The methods employed to ascend to the nest of a bird of prey depend, in each instance, upon its site. If the nest is in a tree, a man can climb up and, having put the young ones in a basket,¹ carry them home. If, however, the eyrie is built in the fissure of a lofty rock, a man is secured to the end of a rope and descends or is lowered from the rim of the mountain or cliff to the level of the hollow in which the eyrie is built and, entering, lifts the bird from the nest. Other means have been devised of reaching a falcon's nest; but the chief aim of the falconer is to carry the eyases (or nestlings) with the greatest care, foresight, and caution to the mews where they are to be raised.

CHAPTER XXXIII

OF THE ENCLOSURES FOR FALCONS AND OF THEIR FEEDING

We are now to discuss the quarters in which the newly caught nestlings are to be raised, as well as to speak about their food and other matters relating to their welfare.

The mews chosen may be a tower somewhere in the country, or an isolated, high building with no forest or trees near by;² for

¹ *in calatho.*

² There can be little doubt that Frederick II is here describing the country around his Castel del Monte in Apulia.

young falcons should be fed and raised in surroundings similar to those the parent birds would have selected, i.e., in some elevated spot far from dense forests and with a large open space without many trees, similar to the open country they prefer for their hunting. If they are brought up in the midst of a forest they will be found, on completing their growth (though still weak), flying about, away from their hacking ground, in the fields (their normal habitat) and seldom returning to the place where they are fed, although young falcons, like other birds, as long as they continue to feel weak and unreliable and are fed by others, always return to their feeding ground after flying off for a short time. In consequence, these young birds are not easily recaptured, because they take more pleasure in the open country than in woods and tree-shaded areas, and from the habit they acquire of leaving such wooded feeding places they may eventually fly off and be lost.

As to the place where young goshawks should be reared, there are other details to discuss and these will be fully considered in the book especially dealing with those birds of prey.

When a suitable location for the care of falcons is found, an artificial nest must be built of materials like those of the wild eyrie. This small place should be open on three sides (to the north, east, and west breezes) and exposed to the morning and evening sunshine. On the south side it should be closed to prevent the south wind (*austrinus ventus*) from harming the birds by drawing up the humors of the head, making them sluggish and weak, and so that the rays of the midday sun² may not reach them. To protect them from hail and rain the mews should be covered. This arrangement will permit their natural body

² At this point in the Vatican Codex (after folio 58) one folio is missing. The entire passage is given, however, in the Old French MS. (12400) of the Bibliothèque Nationale, and in all the six-book manuscripts.

heat to maintain the surrounding air at a normal temperature and cause their feathers to grow stronger.

Near by in the mews there should be placed water in a basin or tub about half a foot in height, making it possible for the birds³ to bathe [?] whenever they wish, although these birds rarely drink. The water should neither overflow nor entirely fill the basin. Were it full, the young falcons would be afraid to perch on the rim and even more to step into the vessel. The tub should be circular and spacious lest the wings and tail of the falcon be damaged.

The mews should also be provided with proper perches, upon which the birds can rest and to which they will readily return. In this way their feathers will be less soiled by contact with their mutes or damaged by rubbing.

Having described the preparation of the mews in which the young falcons should be placed to feed and to mature, we must now say a word about their food and its preparation. It is necessary to distinguish between suitable and unsuitable foods and to know in what manner and amounts the various viands may be given. It is also important to understand how often and at what hours young birds should be fed. The best means of acquiring this knowledge is to observe the feeding methods of the mother bird, for her system of nourishing her young is far better than any one man may devise, and it should therefore be adopted.

Until they are strong and able to fly, and while they are still too young and delicate to tear flesh, the mother bird brings food to them in her crop and vomits it before them. This may consist of avian flesh, or, when birds

³ In the Bologna Codex this passage reads: *ut possint quando volent, licet hoc genus avium raro bibat*. The Codex of the Bibliothèque Nationale says *qu'il puissent boivre* (fol. 96^r, col. 2, l. 1), and the Valencia MS. (fol. 58^r) reads *ut possint quando volent bibere*. The Bologna chapter rubrication gives *de tina praeparanda ad balneum*.



inerte nositer genit carit for
 caridine totu: 7 unguam: rei
 ipse non possunt deare carnea
 nec minuate. sicut sub: car
 dicit: dicitur ut pms qui du
 tur de minuatim iadum
 7 minuatim ante eos ponant
 sup tabulam unam lignea: et
 hoc sunt tanto durgenti cura
 qnto carit unioce. Nam pi
 culum e in nutriendo tam pa
 ude: 7 esse q: nra vna un
 com consurgunt: 7 caritas ex
 ventur. ad id quod intenditur
 q: manus labuerunt de nuti
 nando matris. pter hoc du
 tum e sup q: qnto maiores
 poterunt carit de nra et
 trantur. am uero adules et
 maiores carit poterunt car
 carnes minus tenere: 7 min
 minuate qm pms. p eo q: ai
 carit: 7 unguis: minuatim
 cas. hoc enim arca: alia co
 medentia carnes faciunt ai
 tenere: sup hoc faciunt iug
 capures cum unguis: tenent
 que: 7 ai carit fidente. ad
 hoc iure madunt: 7 minui
 tant ut melius transfluat
 7 digerant. Illi uero qui no
 valent carnes: 7 pter h: dant
 casum recurrem: aut receta
 minuant: 7 ponunt ante eos
 7 carit dno q: nec caritas

nec receta sine salite aliq
 modo. Et illi qui in deserto
 caritum dant oia ana lacte
 hoc modo faciunt. Accipiunt
 oia galina: 7 nimpur: ca
 7 macta uel capite lacte car
 ferca: que tamen sic flagrata
 possit ai: si in nimpendo o
 uum remouent similitatem
 teste ou: 7 albumen: 7 uirel
 lum: postea deponunt in car
 7 implem lacte carite testa:
 7 miscent cum ouo macta et
 quot erunt oia: tot testas im
 plebunt lacte: 7 miscebunt: 7
 simul nra sup agitando de
 coquunt ad leuatum ignem
 caritissim ut uer fiant du
 ta nec mollia: 7 bini qodi
 esta repida dnta pulis capite:
 melior est qm receta ul: case
 us: 7 de esta qualis esse debet
 7 qualiter pparata dictum est.
 Quarta autem ali: nec sic
 supflua nec diminuta. Nam
 si ene supflua: nec euident
 tur non enent: si euident
 non nutrit eos: 7 carit: nec
 si non euident: non poterit
 digerere: quia multus. Et ex
 cibo si digendo sequitur suffe
 caris calidus natur: illis: 7 et
 hoc malum nutrimentum: et
 debitas unum: 7 granitas
 membra: 7 q: lano malari



PLATE 69.—Falconers preparing food for their birds (Folio 59^v, Vatican Codex).
 Note especially (below) the preparation of the milk-and-egg
 mixture. It is noteworthy, also, that the last man on the
 right is the only bearded figure in the manuscript.



PLATE 70.—Two falconers coping the talons of a hunting-bird, and designs for making and tying a jess. (Vatican MS. Pal. Lat. 1071, folio 63^v)

are not available, of four-footed beasts upon whom she can prey. This meat, warmed in her crop, finely divided and partially digested, she gives to her offspring; for they can more easily assimilate meat torn to bits and predigested, especially when fed to them in proper quantities and at suitable hours, i.e., morning and evening.⁴ When their beaks and other members have grown stronger, the mother no longer feeds them from her crop but fetches in her talons deplumed birds that she places before the fledglings. Or she may deplume her quarry in their presence or bring them other food if she has failed to catch a bird. She has also methods of enticing her young from the nest once they can fly, and of teaching them to hunt and feed themselves.⁵

This routine of the mother falcon in feeding her young birds should be followed as closely as possible by him who would have well-developed hunting birds of good quality and healthy plumage. The flesh of birds is more suitable than that of other animals for raising fledglings, because birds resemble one another more (in flesh) than they do quadrupeds. Moreover, the parents, following the nature of their kind, enjoy the flesh of birds rather than that of other animals, since it is more easily and completely converted into suitable nutriment. Wild birds (especially those that feed on grain and fruit) furnish more sustaining and better food than those of the barnyard. Wild fowl that eat meat, particularly worms, are less nourishing. The flesh of birds that feed on fish is the least desirable. Young falcons should be given the flesh of domestic fowl, like hens and pigeons, only when it is impossible to secure birds of the fields, such as [wild] pigeons, doves, thrushes, larks, wrens,⁶ partridges, and other small birds that are generally considered good

as food. Or, failing wild birds, they may be given small wild animals—goats, gazelles, fawns, hares, and rabbits. In default of all these, feed them the flesh of such domestic animals as sheep, goats, pigs, lambs, and kids—always choosing the healthiest specimens. Nevertheless, it is a good plan to substitute domestic food at times for the flesh of wild birds and quadrupeds, especially as the latter is not always available. In this way the home-grown product will be less harmful, because the young bird has become accustomed to it. However, the flesh of domestic animals does not agree with the growing falcon as well as that of wild beasts, for the farm animals live in less pure air and consume less suitable food than their wild counterparts. The former also get less exercise while searching for food and have more superfluous fat. The larger the species of quadruped the less desirable is their flesh as food. This applies to such large animals as horses, oxen, cows, and camels. The flesh of mice is rarely fed to falcons, though it is good mixed with other meat, as it furnishes both food and medicine. Mice are not to be had in large numbers. When the meat supply is exhausted one can substitute fresh or cooked cheese,⁷ or eggs cooked in milk. The manner of preparing the latter we shall explain later.⁸

Some falconers feed their birds of prey, young and old, on aquatic animals such as eels and fresh- and salt-water fish. But such birds become heavy, and we, who inveigh against the use of fish-eating birds as an article of diet for falcons, find the use of a fish diet even more reprehensible. Birds fed upon fish have soft flesh and⁹ feathers, as well as poor humors.

Of feeding methods we have already

⁷ *recocta*, the Italian *ricotta*, similar to our cottage cheese.

⁸ In this same chapter, pp. 134–35.

⁹ This marks the end of the folio missing from the Vatican manuscript.

⁴ Cf. Book II, chapter ix, p. 117.

⁵ Cf. Book I, chapter xxiii-H, pp. 53–56.

⁶ *cistate*.

spoken, but we shall say something further about the sort of food suitable for young falcons. The flesh given them must be raw, because it agrees better with the greater heat of the stomach than does cooked meat; moreover, we know that the parents gorge their offspring with raw meat, hence we may conclude that the young birds need it even after they are full grown. This flesh should be as tender as possible, free from nerves, veins, arteries, cartilage, bones, and fat, all of which are difficult for young falcons to digest. The tenderest meat is always that from plump and not from emaciated birds and tame and wild animals.

Finally, this food should be quite fresh, because it is then in its normal state and still has its natural warmth and its attractive taste unchanged. When meat is allowed to lie about some time after it has been cut from the animal, its natural heat is dissipated, external influences affect it, its juices are corrupted—in fact, it is spoiled and acquires a bad taste.

If, on any occasion, fresh meat cannot be obtained, meat that has been standing and cooling for a short time only may be used in the following manner: it should be soaked in fresh, warm water until it reaches the normal temperature of the live animal before it is fed to the falcons. Treated in this way it is less harmful.

Furthermore, the flesh should always be taken from a wholesome animal, as that from an unhealthy subject is of no use as food; it is as harmful as if it were actually diseased. The birds or beasts that furnish this food must be middle-aged, so that it can readily be digested and converted into nutritive materials that yield stiff and compact flight feathers. The flesh of very young birds (or beasts), whether they be tame or wild, furnishes more or less feeble sustenance, depending upon the particular animal from which it is taken. That is the reason young chickens yield little nour-

ishment. They furnish soft meat that soon disappears as mutes—an indication that occasionally one should prescribe the flesh of young animals as medicine, to keep the falcon's stomach in a healthy condition. On the other hand, the flesh of old or very old animals yields nutritive supplies that are dry, hard, and likely to cause serious indigestion.

All food described as being of proper quality must (owing to the undeveloped strength of mandibles and talons that in young birds are too weak to tear and rend their pabulum into small pieces) be cut up very fine and spread out on a board.

The younger the falcons the greater the care that should be taken to carry out all the foregoing rules. Artificial feeding is at best a doubtful undertaking. Without the assistance of the parent bird, even the closest attention to feeding properly captured nestlings will often fail to make useful hunters of them, especially if they are taken very early from their nest. Their removal from the eyrie should, as previously urged, be postponed as long as possible.

Adult and older falcons can safely be fed meat less tender and less minced than that prepared for an earlier period in life, because mature birds have sharp beaks and claws capable of tearing their food into minute portions. This operation, which carnivorous animals perform with their teeth, birds of prey perform by holding the meat with their talons and cutting, tearing, and mincing it with their beaks, so that it may easily be swallowed and digested.

Whoever has not a supply of meat on hand and is compelled to substitute for it either fresh or cooked cheese should give it divided into very small pieces and be sure that it is not salted.

If it is decided to feed one's falcons eggs and milk (owing to a lack of flesh), the following recipe should be followed: The whites and yolks of hen's eggs, the empty shells of

which must be preserved intact, should be placed in a wooden bowl or an iron cup that has been well tinned. The shells, that have been opened at the top, should now be filled with milk, which is then mixed with the eggs. The mixture must be cooked slowly over a charcoal fire, stirring it meanwhile, until it is neither hard nor soft. This decoction, served lukewarm, is better for the birds than either cooked or fresh cheese.

Food may be fed young falcons in too large as well as in too small amounts. If too much is swallowed, it may or may not be vomited; in the former case the bird is weakened and becomes exhausted; in the latter instance digestion is checked on account of the stuffing of the stomach and the lessening of the natural heat, from which result bad nutrition, weakness of the limbs, and the retarded growth of the pinions. If too little food is given, the natural avian warmth dies out, as does a fire insufficiently supplied with wood; the bird gets thin and weak, while its feathers become ragged, out of shape, and lacking in length. One should give young and small falcons less and the older and larger ones more than the average amount of food—each one according to its degree of natural heat.

A sanguine temperament is always a sign of a good digestion. As Hippocrates, in his *Aphorisms*, says, those who are promptly and well supplied with food pass it (along the intestinal tract) quickly and in good measure; they have a warm stomach, which furnishes a rapid and excellent digestion and proper stools; but a cold stomach is associated with a poor digestion, usually the result of improper food or of some affection of the digestive apparatus.

For the reasons just given, one cannot state absolutely the exact food requirements of his falcons, but much depends upon the extent to which the voracity of each one is aroused; a normal nature desires only the amount that

can be digested. One should be guided by noticing when the appetite is satisfied, and cut off supplies just as soon as the crop is filled.

Meat of good quality can be given in greater quantity than unfit viands. Daily rations of the latter should be gradually diminished and, when in possession of proper aliment, the amount of food may gradually be increased until a full ration is once more served. If a very full meal has been fed to a bird, the next feeding should be decreased and given at a later hour. If at the morning or evening meal little food has been consumed, at the next meal the amount may be increased and the hour advanced. If falcons have two meals in quick succession, any inferior food given them should be fed early and in as small amount as possible and the next feeding should be all the more abundant and of good quality.¹⁰

CHAPTER XXXIV

OF THE NUMBER OF MEALS AND HOURS OF FEEDING FOR FALCONS

We may now consider the number of meals to be given falcons in training and the best hours for serving them. At the end of spring and early in summer, when the days are long, newly hatched and very young birds should be fed at least twice daily; one meal, in view of the length of the day and the temperament of the falcon, is not enough. A single large meal would, on account of the diurnal temperature, weaken the stomach and lead to digestive errors; for this reason two meals should be served, but the second one should not be given until the first has been digested. A full repast of raw flesh on top of half-

¹⁰ Frederick II is probably thinking here of the exigencies of long, slow journeys in sparsely settled country.

digested food perverts the course of nature and disarranges its functions.

In birds the proofs of complete digestion are the following: There is no bad smell on the breath; there is no food discernible in the crop, for it has passed into the stomach and thence into the intestines, remaining there for some time; the mutes are frequently voided, especially when the character of the food contributes to that result; the customary hard black portion of the excrement is small and granular, and the soft white portion is very liquid and pure white and without any foul odor.

Signs of undigested food are: A disagreeable fetor of the breath, evidence that the crop still retains a part of the last meal that has failed of assimilation, i.e., some food has passed unchanged into the stomach and intestinal tract, whence portions of it finally escape as ordure; in the mutes there is much sticky, black material and the soft portion is small in amount and emits an offensive smell.

Increase of the black and decrease of the white elements in defecation are due to an alteration in the digestive process—reminding one of the progress of a fire in a limekiln, where the stones at first are dark-colored but, as combustion continues, they slowly become whiter the more they are roasted.

CHAPTER XXXV

OF THE BEST HOURS FOR FEEDING HUNTING BIRDS

The most desirable time for feeding birds of prey is in the early morning before the third hour,¹ when falcons have already digested their previous meal and the heat of midday will have no chance to affect food remaining in the crop and stomach and so retard its digestion. Of evening hours, that

¹ Nine o'clock.

just before sundown is preferable, so that the birds may have a good night's sleep, which also assists eupepsia; that is also the occasion on which the parent birds fed them their latest meal. Enough should be eaten in the early morning to suffice until nighttime, and their late repast should satisfy them until next day.

Whoever feeds the birds should not be accompanied by others but should wait on them alone; in fact, the less frequent his visits the more likely he will wean them from the bad habit of screeching and keeping their mouths wide open (gaping).

The keeper who feeds the birds when they begin to grow and are able to fly about must not try all at once to tame them and train them. He should allow them to fly at hack² so that they will grow better and stiffer flight feathers. Good weather and bad, open air and sunshine, favor their development and make the falcons stronger and better flyers. Do not be afraid that they will fly away, for they are certain to return for their food; indeed they stand about their feeding ground much in the same manner as they flit about the eyrie. One may confidently allow them their freedom, especially as in or near the mews there is no one to drive them away, as their parents would have done. They ought to be encouraged to fly about at hack at least until they are strong enough to hunt for themselves.

CHAPTER XXXVI

OF THE HACK HOUSE FOR EYASES AND ITS USES

When falcons are to be taken from the hack house all openings into it should be closed except one. This opening should be provided with a door, or shutter, that can

² *volare huc et illuc.*

be closed in the evening and through which the birds can easily be removed without hurting them—an act that ought not to be practiced before the time comes for taming them on the fist. It is permissible to fit the falcon's jesses to her before she is able to fly abroad, and she may wear them while at hack. This makes it easier to catch the young bird in a darkened room when the time comes to take her up for manning. When jesses are worn on the hacking ground, however, there is always danger that eagles and other birds of prey may attack the wearer (because they mistake the jesses for prey) and so drive her away. Hence we do not approve of their use at this time.

When the time arrives for taking the newly caught falcon out of the hack house, all openings but one are closed for three days. This one should have a shutter that can be closed on the third night when the young birds are to be taken up. This operation should be accomplished in the following manner: when the eyases are strong enough to be handled, the falconer should enter the mews accompanied by one or two assistants carrying a candle. The capture of the bird to be removed should be effected at night, because in the daytime the young falcons, somewhat wild from flying about in the open, would struggle for freedom, and fly about, striking themselves against various objects, probably hurting themselves and damaging their flight feathers. Therefore it is at night that they should be caught. A light is carried so that the falconer may see where the falcons are. The candle is then removed and a bird is caught. The two assistants are of use in seeling the falcons and adjusting the jesses. The falconer, accordingly, enters the hut and catches any one of the birds in both hands, taking her by the back, his fingers reaching to her breast. Great care is observed that the falcon is not in any way injured, especially in her wings or feet.

CHAPTER XXXVII

OF THE SEELING OF FALCONS

As soon as a falcon has been caught and before she has been placed on the hand, she must be seeled, the sharp points of all the talons blunted, jesses fitted to the feet, a bell affixed to one foot and, if necessary, the swivel and the leash adjusted.

The operation of seeling is performed because it is necessary to occlude the falcon's eyes so that she cannot distinguish objects about her. This operation is called blinding or seeling. If this plan is not adopted, and the bird in consequence sees the face of a man or any other unfamiliar object (for the first time especially), she may become frantic and unmanageable. Seeling is an operative procedure for closing the eye by raising and holding in place the lower lid to the lashes of the upper.

If it be argued that it is not necessary to seel the eyes of eyases, since they are already on more or less intimate terms with men and surrounding objects and are thus naturally quieter than older, wild-caught falcons, it is nevertheless true that as a result of this procedure the nestling not only becomes tame much sooner but has better limbs and flight feathers and is more amenable to training; hence it is good practice to adopt it.

In seeling, the bird is firmly held in the hands of an assistant, who passes his fingers over the breast, pressing gently on the wings and back. He must avoid all undue pressure on the body so as not to impede breathing. Someone must hold the legs and feet to prevent interference on the part of the bird with the operation that is being performed.

If it is necessary to take up the falcon in the heat of the day, the assistant should first, with his free hand, wrap about the falcon's body a moistened linen towel, so that the body (completely swathed in it) is held with the

hands over the towel. An assistant should now grasp the feet and gently press them against the lower part of the body. The operator, taking a round needle (a triangular needle is not to be used, as it is likely to cut the lid) equipped with a long linen thread, inserts the point between the eyeball and the lower lid and, lifting the latter with the point, he pierces it and draws the needle from within outward. Were he to operate in the reverse direction the eyeball might be injured by the point of the needle. He must also keep clear of the membrane (*membrana nictitans*) that lies on the eyeball between it and the lid, and be sure not to include it in the stitch. Nor is it wise to take up too much of the lid, as a large tear might impair its protective value. The suture must not be placed too near the lid margin lest it afterward tear its way out.

The perforation, therefore, should be just under the margin of the lid at its midpoint. The longer portion of the thread is then passed over the falcon's head and the lower lid of the remaining eye treated in the same manner. When the needle has been removed, the loose ends of the thread are joined over the falcon's head and both lids are drawn upward to cover the whole eye so that the falcon can see nothing. The ends of the thread are then tied firmly so that the eyelids are held securely over the eyes and the two ends are sealed.¹ Then, using the blunt end of the needle, the feathers of the crown are laid over the sutures so that they cannot be misplaced or broken by the claws of the falcon.²

It would be well to blunt the points of the claws by the use of scissors; and this may be done as soon as the falcon arrives, or after she has been seeled, or when she has been

fitted with jesses and made to stand on the fist of the falconer—it seems to us a matter of indifference. In carrying out this measure, care should be taken to remove only the extreme points of the sharp talons—not enough to injure the falcon or to cause bleeding. The needle-like nails should be sufficiently blunted not only to protect the hand of the falconer but to insure that, if he wears a glove, the talons will not pierce it or become entangled in the seam, which would be injurious. Also, were the talons too long, the falcon would not stand comfortably upon the fist. Moreover, when two birds loosed at the same time fly at the same quarry, the falcon with blunted claws is not so likely to harm her associate.

CHAPTER XXXVIII

OF JESSES AND HOW THEY ARE FITTED

We must now further discuss the falcon's jesses, her leash, swivel, and bell, and everything else necessary for the falcon's equipment and care.

Jesses are really leather snares to be placed on the legs. They are used in holding the falcon and are released when the falcon is slipped.¹ There are various kinds of this foot-gear, including a better sort that is strong and durable and that fits the foot. This form of jess we make as follows: From a piece of soft but tough leather are cut two equal strips the length of one's hand and about the width of a man's little finger.² Each of these lengths is so cut that the end encircling the tibia is broader than the remaining portion, which hangs down. The extremity of the wider portion should be trimmed on both sides, making the tip narrower than the portion in contact with the leg. For gersfalcons and saker falcons the wide part of this strap should be

¹ Bologna Codex, fol. 39, l. 46, *signantur*. The Vatican Codex, fol. 62, col. 2, l. 33, says *incidantur*.

² This procedure fell into disuse later in the Middle Ages, doubtless owing to the introduction into Europe by Frederick II of the hood (then used by the Arabs of Syria), when seeling was found to be as needless as it is cruel.

¹ To "slip a falcon" is to release her to fly at quarry.

² Bologna Codex, fol. 39, col. 1, l. 4: *lata secundum latitudinis unius digiti hominis qui dicitur minus*.

somewhat broader than a small fingerbreadth. For peregrines, true noble falcons, and laner falcons the jesses should be the width of the little finger. In every case they should fit the particular bird for whom they are intended. The lower part, which hangs loose, must be narrowed to about half the breadth of the upper portion.

When the straps have been shaped in this manner, the extremity of the wider portion should be pierced in the center by a slit long enough to permit the insertion of the other end of the jess as far up as that wider part that encircles the falcon's foot. Now a second slit must be made in the strap at such a distance from the first that the portion of the jess lying between them will encompass the tibia. It is best to place the leather strip about the falcon's leg and measure accurately the distance between these two slits. The perforated end is now drawn through the second slit until the first perforation has passed through the opening; then the narrower, longer, unperforated portion of the jess is picked up and inserted in the first slit (that was previously passed through the second slit). These two perforations have now been interwoven to form a sort of knot. In adjusting the two jesses to the falcon's legs, the upper edge of each jess should be drawn a little tighter than the lower one, so that when the falcon lifts her foot it may not be hurt by the pressure of the knot against it. The whole jess must be tight enough to prevent the passage of the bird's foot but not so snug as to press on the tibia. It is harmful to adjust the upper and lower edges of the jess with equal tension because this frequently leads to an inflammation of the foot and it then assumes a gouty (swollen) appearance.

A further requisite is two rings like the mesh of chainmail,³ made indifferently of iron, bronze, or horn. The unperforated end

of the jess that hangs down behind the foot is now passed through one of these rings, and folded back, stitched down or knotted close to the ring so that the latter may not slide back and forth. The jess must be made so long that the distance between the stitching of the ring and the knot at the falcon's foot is equal to the falconer's middle finger. This distance may be measured as follows: Place the stitching that holds the ring in place upon the outside of the joint of the middle finger nearest the hand and extend the finger along the strap; the tip of the finger should touch the knot made in the jess near the foot.

There is a right and a left jess, and it is well to distinguish them so that they may be correctly adjusted for the comfort and agility of the falcon. The short, wider portion of the jess should encircle the tibia from within outward, so that the longer part that is held between the fingers (of the falconer) hangs from the inner side. The jesses are now ready to be placed upon the falcon's feet and knotted in the manner previously described. The upper portions encircle the tibiae, and the longer ends, holding the rings, hang down behind the falcon's feet. These pendant portions (when the hawk is on the fist) are to be passed from the back of the hand between the two upper and the two lower fingers to the inner side of the palm of the hand,⁴ where they are held firmly. When this is done the falcon is prevented from flying off without the consent of her bearer. The jesses also serve as an attachment for the leash.

CHAPTER XXXIX

OF THE LEASH, ITS PREPARATION AND ITS USES

The leash is a long leather strap, by means of which falcons are secured to a perch and

³ "*ad quantitatem anuli seu maylle loricarum,*" Bologna MS., fol. 39, col. 2, l. 20.

⁴ *Ab extrinseco manus ad intrinsecum.* See Book II, chapter xlii, pp. 143-44.

held fast under all conditions.¹ It is fashioned from strong soft material cut the same width throughout except at one end, where it is a little narrower. It must be narrow enough to pass through the two rings attached to the jesses. On the upper end is a knot that prevents the leash from being pulled entirely through the rings. When the leash is ready, its narrow end is inserted in the rings of the jesses and the strap is drawn through for three-quarters of its length. [A cut is made on the leash to form a hole close to the rings on the side nearest the knotted end. The long, narrow end of the leash may be passed through this slit and drawn up to hold the rings together, or else]² the two ends of the leash may be tied in a knot to hold the rings together. When tied in this manner, and the falcon is on the wrist, the two ends of the leash should be held in large free-hanging loops over the falconer's little finger so that the bird may be carried comfortably. When the falcon is not being borne about on the falconer's fist, she can be fastened by means of the leash to her perch in the manner we shall now describe.

Some falconers tie the leash directly to the jesses (that are not provided with rings) by means of knots, but by using our method the work of tying the falcon to and unloosing her from her perch can be more quickly accomplished.

The leash is used not only to fasten the falcon to her perch but when she is first flown to the lure it is the means of attaching her to the line (or creance). It is also employed to secure birds firmly while they are having their baths.

¹ Here Frederick II adds this explanation of the use of the word *longa* to denote the leash: *Et haec sua longitudine comparata ad jactos meretur dici longa*. He might have added that a jess was called *jactus* because it is used in throwing the falcon from the fist.

² The short passage in brackets is given only in the Vatican Codex, fol. 64, col. 1, l. 32.

CHAPTER XL

OF THE SWIVEL, ITS USES AND METHOD OF FASTENING

The swivel is made of two small metallic (iron, brass, or silver) rings equal in size to those attached to the jesses. At one point of each ring the circumference should be a little broad and flat, where a hole is made through which a common pin or bolt is passed and fastened to the two rings so that it cannot slip out one way or the other. Arranged in this manner the rings are free to revolve one upon the other. Whenever there is danger of the falcon's jess and leash becoming entangled, the rings of the jesses may be tied to one of the rings of the swivel, using bits of soft leather for that purpose.¹ To the remaining ring of the swivel the leash may now be fastened in the same manner used to attach it directly to the jesses. This device is of great value in preventing serious annoyance to the falcon caused by entangled footgear.

CHAPTER XLI

OF THE FALCON'S BELL²

Falcon bells are made of sonorous metal that emits a clear note. They are large or small to correspond with the size and strength of the hunting bird that is to wear them. The holes in them should be so small that the falcon cannot insert one of her curved talons into them and so become entangled with the bell. The lug of the bell also should be pierced

¹ These bits of leather are known to the falconer as "bewits."

² *Campanella quae etiam nola dicitur*. These two names have a common origin when applied to bells. The tradition is that Paulinas, Bishop of Nola in Campania, in the days of Hieronymous (St. Jerome, A.D. 340-420) was the first to make use of bells in the church service. These church bells, large and small, were therefore called after the town and district; but later the name *nola* was dropped and the various forms of *campania* were retained.

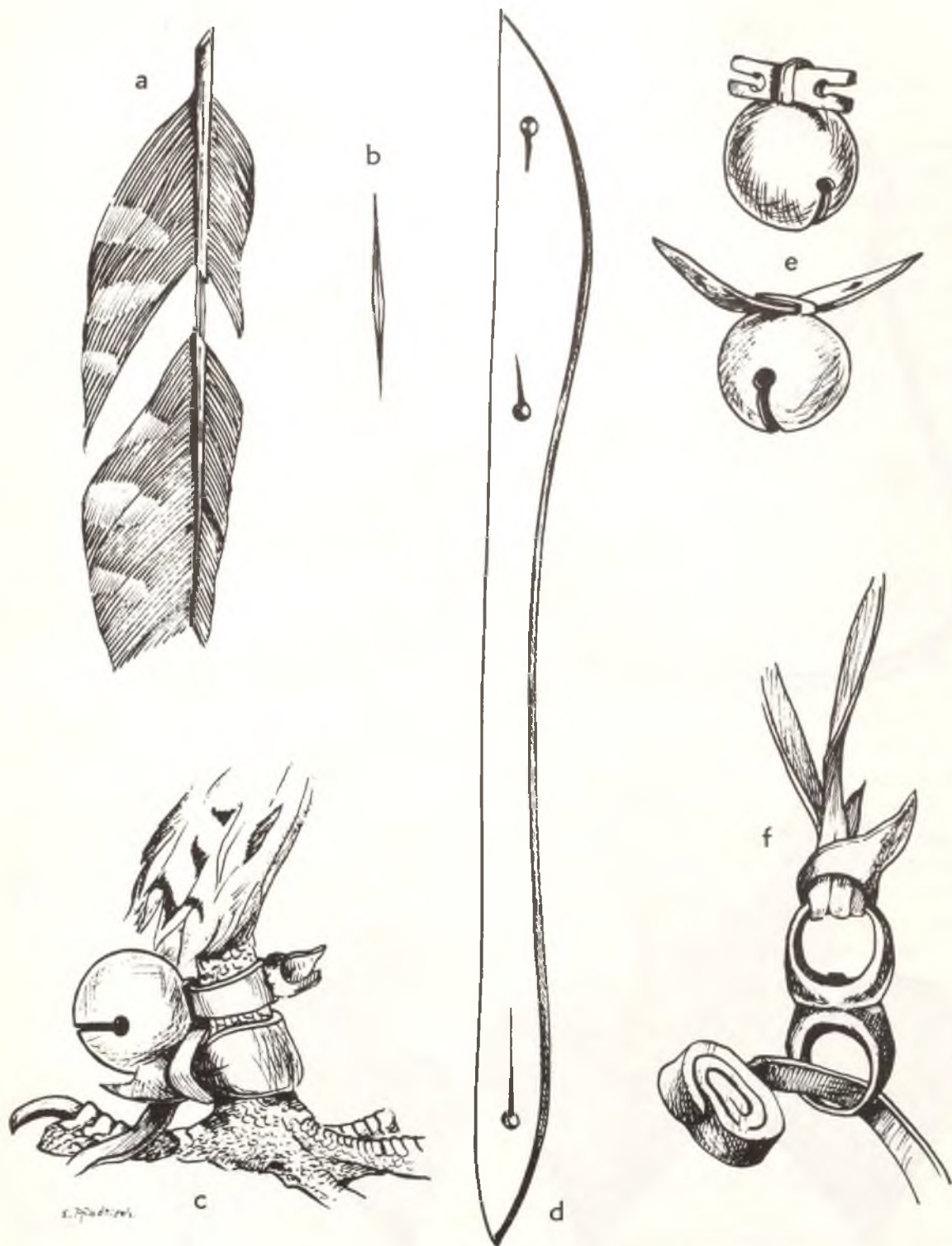

PLATE 71.—Accoutrements of a hunting-falcon: *a*, *b*, imping method with needle; *c*, jess, bewit, and bell attached to hawk's leg; *d*, leather strip (enlarged), or bewit, for attaching bell; *e*, *e*, bells with attachments of leather; *f*, swivel with jesses and leash attached.

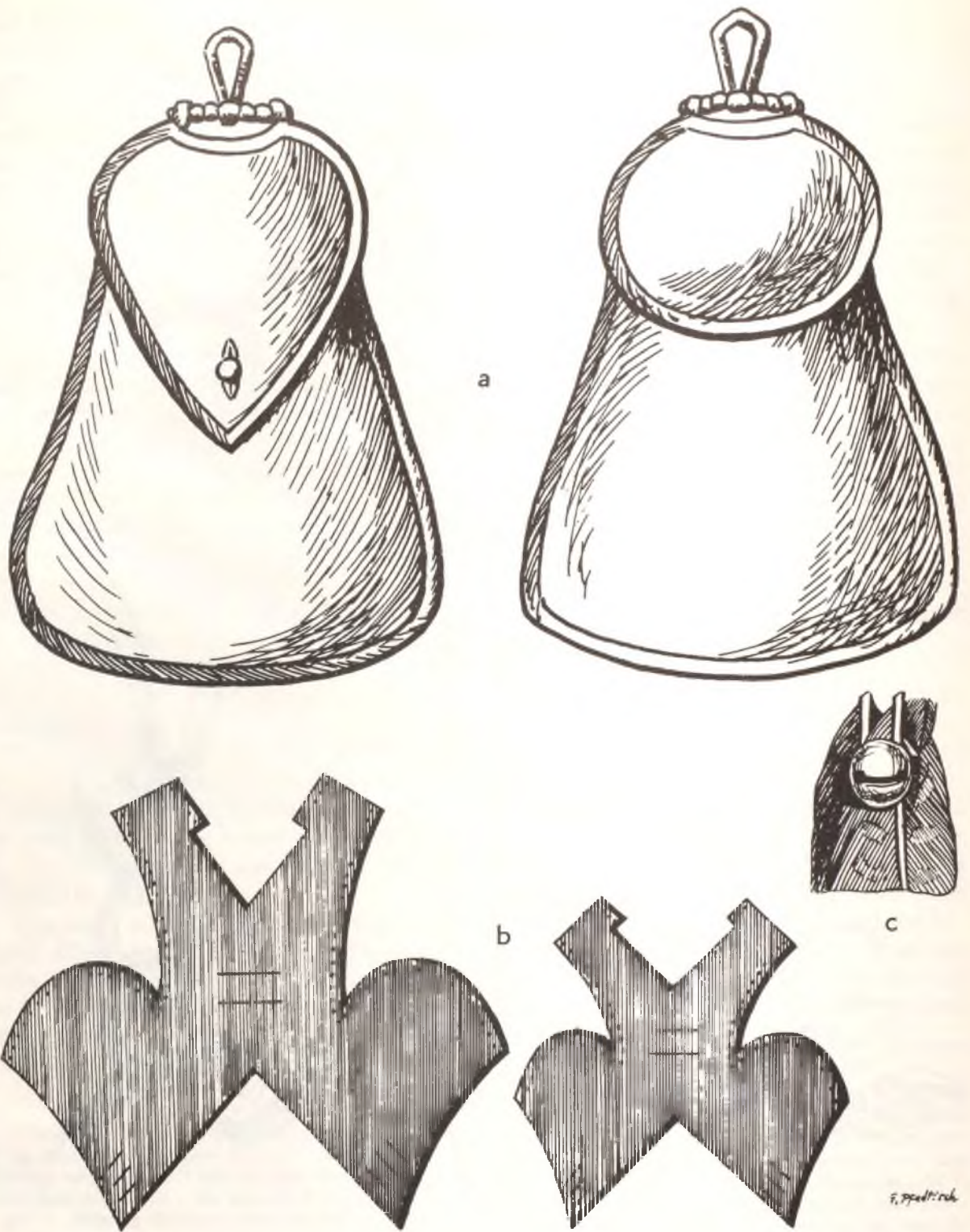

PLATE 72.—Hawk's furniture: *a*, Falconers' purses without ornament; *b*, pattern for making the hood; *c*, Chinese method of attaching the bell to the middle tail feathers of the falcon, a method disapproved by the Emperor.

with a hole to receive a piece of leather (be-wit) with which to tie it to one of the bird's feet. The bell is attached above the jess on the tibia, but not by a thong so short that it will injure the shinbone, nor one so long that the bell will dangle about the leg.

These bells have several uses. The falconer knows at once from their ringing that the falcon has flown down from, or fallen off, the perch and can hurry to her assistance. The bells can also be heard from a long distance wherever the bird happens to be, so that she may more easily be found when lost or out of sight. From the character of the bell notes the expert knows whether his bird has sprung off the perch, is scratching herself, or is biting her jess or the bell near it.

Another method of attaching the bell to the body of the bird is to make a hole in the two medial tail feathers and so affix the bell. I am opposed to this plan, since the tail is thereby dragged down in an ugly fashion and the feathers themselves are likely to be injured.

CHAPTER XLII

HOW TO CARRY A FALCON ON THE HAND

After one has thoroughly studied all that has been taught him in previous chapters, he may more readily learn how the *eyas* should be trained to stand on the fist and how she may be carried about.

The first positions to be practiced are the following: The falconer's upper arm as far as the elbow should be allowed to hang loosely at the side of the body. It must not be held so close that it reflects every movement of the body, otherwise the bird is more likely to be disturbed. The lower arm is kept at a right angle to the upper arm, and the hand is extended in a straight line with the arm and not moved either forward or back. The out-

stretched thumb is laid on the forefinger and the latter is bent to touch the last joint of the thumb, exactly as an Abacist monk would make the sign for the number 70; then pressing the remaining three fingers against the palm of the hand, one makes the sign of the figure 3. A combination of these poses, i.e., the bending of the index finger on the last joint of the thumb and the pressing of the other three fingers against the palm of the hand forms the Abacist figure 73, and from these combined positions we have the proper posture of the hand and arm for holding a falcon while she is being carried about.¹

The falcon should be held during transport opposite the shoulder, for when without her hood (or unseeled) she must be held out of sight of the carrier's face until she is manned, since it is in the nature of the bird greatly to dislike the human countenance.

The foregoing rules apply equally to both hands and arms of the falconer or his assistant in transporting hunting birds; and he should learn to carry the falcon on either fist, for he must bear the bird on his right hand if the wind blows from the left side and on the left hand if it comes from the right. In this way the falcon's breast is always exposed to the breeze that does not ruffle the feathers of the tail and back, nor those of the rest of her body. A disturbance of her plumage she will not stand, but will always turn herself about to avoid it.

In some countries falcons are borne only on the right hand. The exponents of this method severely criticize any other. We firmly hold that hunting birds should be carried afield on either fist exactly in conformity with the regulations just laid down, and for the reasons given.

The falcon should also be carried on the

¹ Schneider's commentary on this ingenious illustration by the Emperor is that it was the method of counting (in dumb show) adopted by Abacist monks, who were sworn to silence.

falconer's gloved hand in such a manner that her claws occupy the space between the wrist and the tips of the bent fingers. When the falcon stands on the right hand the bird's head, beak, breast, and the forepart of her feet are directed toward the left. The ends of her jesses should pass into the hand inside the thumb and index finger and out at the back of the hand between the two upper and two lower fingers.² Some falconers believe it does not matter between what fingers the thongs are held, but it is better that there be two fingers on either side of the ends (so that they may be securely held) and not one finger on one side and three on the other side, where they are not so safe. If the falcon falls off the fist and is not able at once to right herself, she is to be replaced in the posture described above.

The leash should be held in short loops about the little finger of the hand holding the falcon. In this manner she may be carried for some time with comfort and without danger of entanglement in her gear.

CHAPTER XLIII

HOW TO CATCH BRANCHERS AND OTHER WILD FALCONS

Branchers are taken from outside the nest by means of nets, snares, and other traps, the successful use of which requires the widest experience, skill, and painstaking labor. It is a matter not discussed in this book and we shall leave it to more experienced (professional) falcon catchers; our purpose is to study how we may, to best advantage, hunt with, train, and gain the confidence of falcons (once captured) and they that of the men who look

² Compare this rule with that given at the end of Book II, chapter xxxviii, p. 139. The present passage (Bologna MS., fol. 41) reads: *intromittantur laqui jactorum inter pollicem et indicem inter manum et fiat ut exeant ad exteriorem partem manus inter duos digitos.*

after them. We shall, however, say this—the least objectionable trap is not merely the one that catches the most falcons but the one that takes them unharmed. This consideration holds out the only hope for good results, because those birds that are injured when trapped, either by their own violent efforts to escape or when they are roughly released from a net, rarely if ever recover from such ill-usage; either they die from their injuries or, for a long time, if not always, remain perfectly useless. Consequently we entreat falcon catchers to exercise the greatest care in their work and at least to refrain from injuring their captives in any way, and to give them the best of care thereafter.

There are five different periods when branchers can be secured; first, when they have just left the nest and begin to flutter about the eyrie; next, when they have abandoned the neighborhood of the nest from which the parent birds have driven them although they are still flying in the same region; then, in the autumn when they have begun their first migration, or are preparing to migrate; fourth, in their winter habitat; and, finally, on their return in the spring. They may be caught close to the nest from the middle of June to July; their capture in the vicinity of the abandoned eyrie may occur at any time in July until the beginning of August. From the beginning of August until the cold weather sets in (the middle of November) falcons are on their journey south. (Birds caught at this time are called passage falcons.)¹ From the middle of June until the end of September there are more true noble falcons² caught in the sixth, fifth, and fourth climatic zones than there are peregrines. In-

¹ Passage falcons are those caught during the southward and return migrations of the first year, before they have had their first moult. After that they are called "haggards."

² The Emperor says here, *plus de gentilibus quam de peregrinis*. Again he makes a distinction between what were probably two types of peregrines.

deed, in localities near the third and second climatic zones this is especially the case, because they have begun their migratory journey at an early date.

By the end of September, as well as during October, more peregrines than true noble falcons are taken, because the former have already migrated. Peregrines hatched late in the season and in the extreme north are seen migrating at this time. In the warmer (more southern) zones the period of migration and, therefore, the period for capturing falcons lasts longer. The season for taking peregrines is shorter farther north, for there the cold sets in early and falcons hasten to seek a warmer climate.

It is difficult to suggest any one place where falcons may be trapped during migration, as they move quickly from place to place and may be caught in many localities. This is true also of their return journey in the spring.

Falcons captured during the winter³ are stragglers that arrive and remain in one locality because atmospheric conditions favor them or because they are satisfied with the opportunities for securing food or because they have suffered some disablement; indeed, they may be captured wherever their avian food supply abounds.

In the springtime many falcons are captured on their return flight to their native country, and for this reason (when taken) are called "return captives."⁴ At all seasons of the year both moulted and unmoulted birds (passage and haggard falcons) are taken, but fewer on their return journey. During this latter flight there is no distinguishable difference between the number of true noble falcons and that of peregrines taken captive at any particular time such as is observed in the autumn. They appear in the spring more irregularly than during the autumn migration,

³ Here again Frederick II is probably referring to southern Italy.

⁴ *capti de reditu.*

for on the southward journey some are captured and some die during the winter.

Generally speaking, one may say of most falcons that the earliest hatched are the earliest caught. As examples, gerfalcons, saker falcons, and true noble falcons, having been hatched early, also are made early captives. Thus it happens that gerfalcons, although born in a cold climate, are hatched early and no later than the true noble falcons that are incubated in warmer localities. They are, therefore, ready for an early capture. When one of these birds (gerfalcons) is caught late in the season, that fact does not necessarily indicate that the captive has made a tardy exit from the nest but rather that she was among the later migrants. Perhaps she lingered because she was able to withstand the cold better than other individuals or because she was born in a more distant region and brought up in a colder climate than the gerfalcons that were caught earlier.

Lanner falcons are captured about the same time as the true noble falcons—some of them even earlier. Peregrines are made captive later because they are born later and in the far north. In short, falcons born early migrate early and are caught early. Those born later migrate late and are captured late.

CHAPTER XLIV

OF THE LOCALITIES WHERE FALCONS ARE CAPTURED

The regions in which hunting birds are caught vary greatly—in keeping with their different varieties and the sort of food they consume.

Peregrines, owing to their usual habitat in distant, cold, and aquatic countries—where there are few land birds, but many waterfowl (the latter being among their prey)—are generally captured most successfully around large bodies of water and near streams.

Saker and lanner falcons, on the other

hand, accustomed to seek their prey in a wide, open terrain, catch—in addition to birds—mice, lizards, crickets, and like quarry; hence they are more frequently found and trapped in dry than in aquatic regions.

Gerfalcon, which sometimes hunt land birds, sometimes aquatic fowl, are made captives both in the open fields and on the banks of streams. They are, however, caught more frequently and easily in the former locality, where they pursue various species of geese that feed on the rich herbage found in large meadows and on grassy plains.

The true noble falcons are as a rule captured in the open fields, because they subsist chiefly on land birds.

Just as soon as a wild falcon is caught (especially if the trapper is alone), the bird should be placed at once in a falcon sock. The captive is then more likely to keep quiet. This act will be all the more opportune if the trapper hopes to catch other falcons on the same day before he returns to the falcon house. Later he may not only seel them but at the same time blunt their talons, put on their jesses, and adjust their bells. If he has an assistant he may first seel the falcon and then place her in the sock, or he may reverse the order, whichever appears at the time to be most convenient.

The falcon sock is a small linen cover, or sack, of proper size to fit the imprisoned bird. It is open at both ends; one opening is large enough to allow the bird's head to project but small enough to prevent her escape. The lower aperture is wider and large enough to permit the entrance of the falcon's body. The sock must be wide enough and long enough to accommodate the falcon from the shoulders to the knees, and it must be fitted with drawstrings to regulate the size of the opening. With the flight feathers and the tail carefully held against the body (as directed in a former chapter), the bird is thrust into the sock and the body arranged so that the head pro-

trudes through the upper opening while both feet as well as the ends of the wings and the tail rest at the lower end. Then the drawstrings are pulled as far as required and tied together.

The falcon thus incarcerated may easily be left in the sock and should be carried (uninjured) to the mews or falcon house as soon as possible, since prolonged confinement prevents the captive from muting—a prohibition fraught with danger to her well-being, because excrement long retained may dry and harden in the belly and be a serious source of disease.

CHAPTER XLV

OF THE SEELING OF FALCONS CAUGHT WILD

If the falconer does not at once seel the wild falcon that he has just put in the sock, the bird becomes frightened and unruly at the sight of human beings and other unaccustomed objects and will make desperate efforts to escape, often injuring herself and breaking or pulling out her flight feathers as well as engendering hatred and suspicion of all men. This is why falcon catchers, when approaching their nets and traps, should do so with averted faces and afterward show themselves to their captives as little as they can.

The operation of seeling performed by one or two men has already been described in speaking of the treatment of eyases. We believe the practice is all the more necessary for falcons captured as branchers or passage falcons, since they are less tame and more affected by the sight of man.

After they are seeled and brought to the falcon house they may be removed from the sock, but must remain seeled. This "blinding" is desirable for various reasons: following the operation, the captured birds are not so restless and do not bate so frequently, since they have no incentive to do it; also men do not become so hateful to them, for they are



PLATE 73.—Common form of block perch for weathering falcons

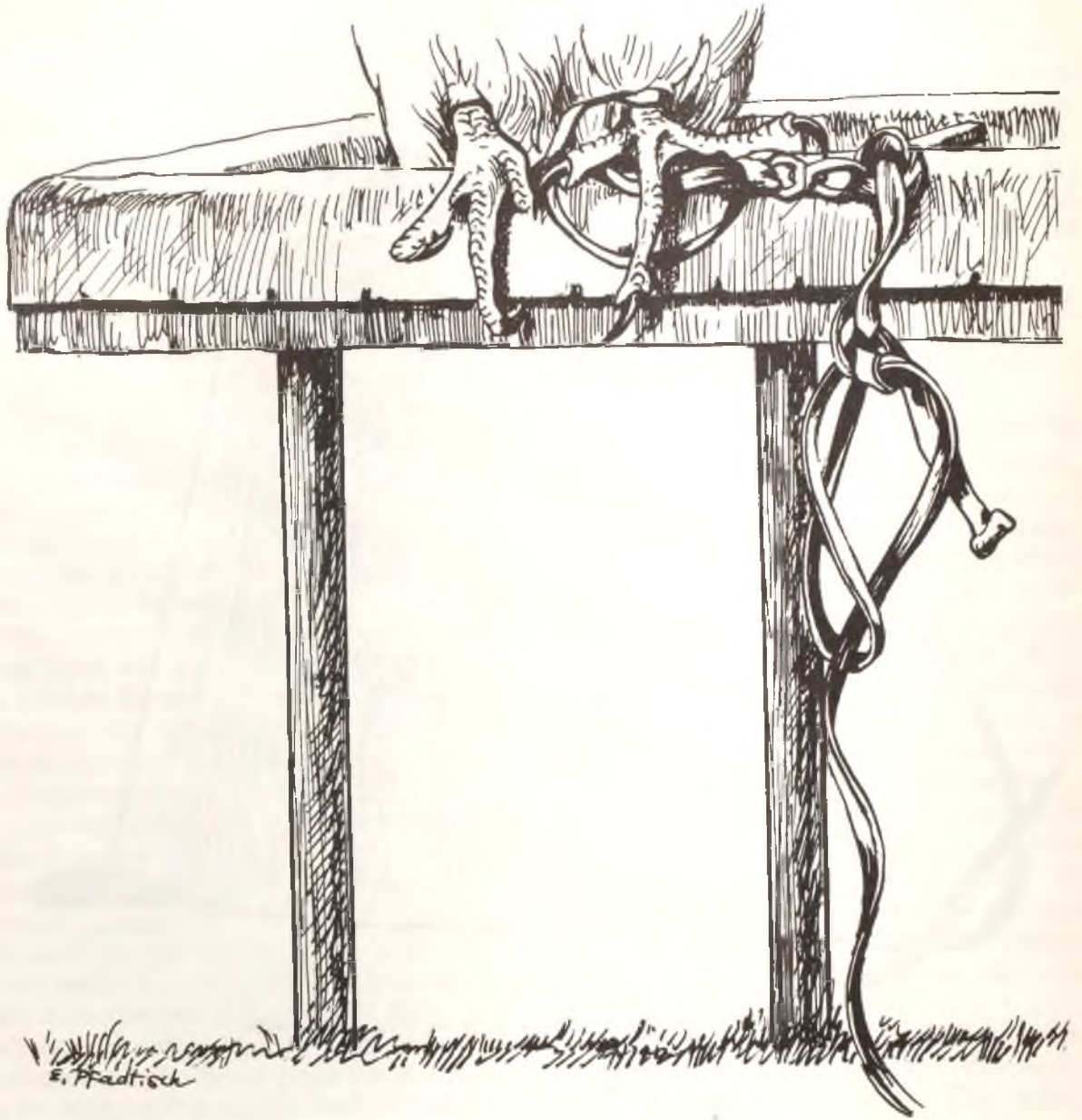

PLATE 74.—One of many types of the padded cage for perching falcons

not seen by the falcon until she has grown to enjoy being with them and being fed by them. Moreover, the falcon's limbs and feathers are protected from injury by seeling; the wild birds are more easily tamed and they submit more readily to subsequent wearing of the hood. Not only is some form of "blinding" necessary for all wild birds but especially for those who do not react to our rules for bringing them up. Seeled falcons are more easily carried around and more willing to be carried.

CHAPTER XLVI

OF METHODS OF CARRYING FALCONS AND HOLDING THEM ON THE FIST

All the (needle-pointed) talons of branchers¹ should be blunted and their jesses adjusted before they are placed on the fist. The exact manner in which all this should be done has already been explained when we spoke of it under the caption, "Nestlings" (or eyases). Those lessons included an account of the position to be assumed by the arm and hand. It is exactly the same in the case of more mature, wild captives. The falcon must be placed upright on her feet and, putting his left hand under her breast, the falconer should lift her to his right hand. If the falcon leaves the fist, her motion should be followed with the hand so that she may be encouraged to return of her own accord. Failing this, she should be assisted to do so, the falconer placing his free hand, as before, under her breast and lifting her back.

The assistant must always carry the falcon as gently and with as little movement of his hands as possible; he should give the bird as few shocks as he can lest she become unruly, try to fly away, and damage her loins and kidneys. It is not sufficient in manning wild birds that the falconer should know that he must carry the falcon in a certain manner, but he

must practice the proper method of such transport and become accustomed to doing it; and this rule applies to every detail that concerns the welfare of hunting birds. He should, in addition to being familiar with the practice, be well informed in the theory of falconry, which he will be able to learn in advance from what is written in our book on the subject.

The signs by which one may judge when a falcon is properly placed on the fist and is comfortably carried there are these: Her wings are folded together and held raised over the back; the tail is in a line with the back and directed posteriorly, and there is no hump² where it borders on the back; all the tail feathers are in good order and neatly folded; the feet have an easy position, while the whole body is supported in comfort and equally on both feet, with no more weight upon one than upon the other. Nor do the talons grip tightly the fist of the carrier; the bird is poised lightly on the hand. When the latter is stirred from side to side, or rotated, to move the falcon, she will herself gently readjust her feet. A wrong position of the bird and improper movements of the carrier's arms and hands are in every way opposed to the directions just given.

Should it happen that a falcon (caught as a nestling, or later) has been badly carried and roughly handled, so that through restlessness she has become worn out and weak (because she was not seeled when first captured), she may be brought into reasonably good condition by seeling her and permitting her to rest. After seeling she should be well fed and placed in a darkened mews upon a low perch to recuperate. Here she must be gently handled and remain undisturbed until she has recovered from her overexertion and mishandling.³

² *non facit gimum.* Bologna MS., fol. 42^v, col. 1.

³ This last paragraph is not found in the Vatican manuscript or in editions derived from it. See the Bologna MS., fol. 42^v, col. 2.

¹ This includes passage falcons.

CHAPTER XLVII

OF FALCONERS AND THEIR
QUALIFICATIONS

Before taking up the discussion of how to train the falcon to hunt, let us first examine the qualifications of a good falconer and the general view which he should entertain of his avocation. We must also discuss the symptoms of disease in the falcon, for success with her training depends largely upon her good health.

He who would be fully instructed in falconry must be proficient in the feeding, the attendance upon, the training, and the domestication of falcons, and in teaching them how to capture their quarry. He must also be well acquainted with numerous other responsibilities connected with these tasks, all of which are discussed in this book. Only then can he be regarded a worthy member of the guild and deserve to be called by the name of falconer.

The falconer should be of medium size; if he is too tall he is likely to be easily tired and not nimble; on the other hand, if he is too small his movements, either on horseback or on foot, may be too quick and too sudden. He ought to be moderately fleshy, so that he is not handicapped by emaciation and thus be unable to do hard work or to withstand the cold; nor should he be so fat that he is likely to shun exertion and suffer from the heat. The falconer must not be one who belittles his art and dislikes the labor involved in his calling. He must be diligent and persevering, so much so that as old age approaches he will still pursue the sport out of pure love of it. For, as the cultivation of an art is long and new methods are constantly introduced, a man should never desist in his efforts but persist in its practice while he lives, so that he may bring the art itself nearer to perfection. He must possess marked sagacity; for, though he may, through the teachings of ex-

perts, become familiar with all the requirements involved in the whole art of falconry, he will still have to use all his natural ingenuity in devising means of meeting emergencies. Indeed, one cannot easily set down in writing all the special duties and contingencies that may arise in consequence of either the good or the bad behavior of birds of prey. Since the habits of birds vary greatly, the falconer must be resourceful in applying whatever he has gleaned from this book.

The falconer should also possess a retentive memory, that he may keep in mind both the good and the evil that he encounters in his contacts with falcons, whether they be his own, the bird's, or of some other origin; he must cultivate the good and avoid the bad.

He should also have good eyesight and see well in the distance, so that he can keep in view—very necessary, this—the birds at which he wishes to fly his hawk; also his own falcon must not be lost to view when she is at a distance. He ought, in addition, to keep a sharp lookout on everything in the locality where he is hunting.

It goes without saying that the falconer's hearing should be acute, so that he can readily hear and identify the call notes of birds he is looking for, especially in the presence of other avian sounds. He must also be able to recognize the voices of his associates and the tones of the bells on his own hawk (that may have flown out of sight), and may even from the call of birds discover the direction of his falcon's flight.

A falconer should have a good carrying voice so that his falcons can hear his signals when they are far apart; and his assistants will be able to understand his directions more easily if he has a strong voice. He must be alert and agile in his movements, that there may be no delay in assisting his falcons when the necessity arises.

He must be of a daring spirit and not fear to cross rough and broken ground when this

is needful. He should be able to swim in order to cross unfordable water and follow his bird when she has flown over and requires assistance.

He should not be too young, as his youth may tempt him to break the rules governing his art. Young people tend to become bored and to be attracted only by successful and pleasing flights. Still, we do not include all youths in this category, since some of them become good carriers of falcons. But, speaking generally, they are not adapted to the tasks required in the taming and the training of birds for the chase; nor should they be allowed at first to fly the falcons. They ought to wait until they not only are skilled in the art but have reached manhood's estate.

The falconer must not be a sleepyhead, nor a heavy sleeper, for much is required of him—he goes to bed late, he must make several necessary inspections of the birds at nighttime, and he must rise early, often before daylight. The falconer ought to be a light sleeper, also, to enable him to hear the falcon's bells, the flapping of the bird's wings, or other indications of her unrest.

He should not be the slave of his stomach (neither too voracious, nor an epicure), whether at home or in the open country; because, if perchance he has lost his hunting falcon, such a one would rather turn back to seek a meal before he has found her or, if at home, he may neglect his bird, forgetting her in the indulgence of his gluttony.

A drunkard is useless. Inebriety is one of those minor forms of insanity that soon ends in destroying the usefulness of a bird; because, although the inebriated attendant may believe he is treating her well, neither he nor any other simpleton should be allowed to have the care of a falcon.

A bad temper is a grave failing. A falcon may frequently commit acts that provoke the anger of her keeper, and unless he has his temper strictly under control he may indulge

in improper acts toward a sensitive bird so that she will very soon be ruined.

Laziness and neglect in an art that requires so much work and attention are absolutely prohibited.

The falconer must not be an absent-minded wanderer,¹ lest because of his erratic behavior he fail to inspect his falcons as often as he should. A hawk may be seriously damaged in a short time, and therefore requires frequent inspection.

He should draw on his glove when he carries the falcon. It should reach to his elbow and be wide enough to be drawn off and on with ease. It must be made of stout leather of a quality that will not permit the talons of the falcon to cling to it and thus be easily pierced by the beak or claws. When the falcon is thrown from the hand, she will rise more freely from such a properly fitting glove.

The falconer should have a purse suspended from his girdle in which the tiring and meat (*carnes*) are carried. Owing to its edible contents, this purse is also called the *carneria*.²

CHAPTER XLVIII

OF CLASSES OF FALCONERS AND OF THE AIMS OF THE TRUE FALCONER

Falconers may be divided into several categories. The chief object of some is to use as food the avian and (occasionally) ground game which their falcons capture. This quarry they eat avidly or make other profitable use thereof. Others think neither of their stomach nor of mere gain, but only of the enjoyment of securing a satisfactory flight for their birds. Others, again, boast and talk about the number of birds their falcons seize. Still others have no pleasure in such accomplishments and aspire to have

¹ *Non sit gyrovagus*. Bologna MS., fol. 43^r, col. 1.

² See Book II, chapter IV, p. 174.

only fine falcons, better trained than those of others, that have gained honor and pre-eminence in the chase. When these aspirations are satisfied they feel they have been fully repaid for their trouble.

The first-named purpose of the falconer is objectionable because it leads to worry and exhaustion of his falcons as a result of his eagerness merely to acquire much quarry for the table. He cannot hope to keep good birds long. Nor are those in the second category more to be approved, since he who has always in mind a desire to see his birds make brilliant flights is difficult to satisfy and is tempted to spur them on to intolerable exertions that are sure to weaken them—a policy that is childish and not correct in its technique.

The third class must also be censured because they are likely to overstep the mark of good falconry and misuse their birds.

It is only the fourth group¹ that is to be fully approved. A falconer in this class secures the best hunting birds available; he does not abuse them, but preserves them in good health and in proper training. He does not overwork his falcons, and yet keeps them up to the mark in all respects. He is the one who realizes the essentials of a noble art.

It should be the endeavor of the falconer who keeps birds of prey, skilled in hunting other birds and certain four-footed animals, to do so in the manner most creditable to himself while observing with the greatest care the noblest canons of falconry.

One should always bear in mind that the very nature of wild birds of prey makes them intensely diffident toward man, while their peculiar instincts and deeply anchored habits render them entirely alien to human beings, whom they shun, fearful of harm to their plumage and other members.

It is upon these considerations mainly that

¹ One must not forget that our author lived in the age of chivalry and the fourth category reflects the pure sentiments of his knighthood.

we should pursue our studies of the falconer's science and art, not only to study the implements employed but to regard the artistic side of the sport. All this is done that the falcon may be partially detached from her normal mode of life and renounce certain peculiarities, replacing them by other (acquired) habits and accomplishments. She must learn to live with man and return to him promptly. Such virtues acquired by training, through patience and the passage of time, eventually become habitual and, as it were, second nature.

In order to effect this change and teach the falcon a new manner of life some special agency is required, and the one found most effective is the sense of taste. To the other senses we can at first make no appeal. The sight of man and of the things about him are terrifying to the falcon as well as to other animals. To touch unaccustomed objects and be touched, felt, and handled by unfamiliar beings is abhorrent to her. The voice of man and other strange noises arouse in her the same instinctive desire awakened by assaults on the senses of sight and touch—to flee far away from man.

Remember, also, how dependent the captive bird is upon her owner: that, for instance, she has restraining jesses attached to her feet; that she usually stands either tethered to her perch or tied to the hand of her master, and may at times be expected to eat off his fist. Moreover, even when she takes her accustomed flights, she is more or less under control of an alien hand. During this period she carries a bell, is seeled (or wears a hood), and when the last-named is removed and she is permitted for a time freedom of action she must fly back to the falconer or wait quietly as he approaches to pick her up, again to be returned to the prison house—all of which is contrary to her every natural impulse. And there remains only the sense of taste through which the bird and man meet on anything like even terms and common ground.



PLATE 75.—Sixteenth-century noble in falconer's regalia with falcon on fist (from an old print)



PLATE 76.—Six-foot wooden figure of St. Gorgon (Gorgonius) a ninth-century nobleman, with falcon on left fist, missal in right hand, hesitating between the worlds of the flesh and the spirit. Figure carved *ca.* 1500. (Courtesy of the Director of the Buffalo Fine Arts Academy, Dr. Gordon Washburn)



PLATE 77.—Lateral view of the statue of St. Gorgon
(Gorgonius, ninth century). Figure
carved about 1500.

uolatus ⁊ plures. nec tamē pu-
eros ex toto repellim⁹ cū possint
esse prudentiores. non ē pueri
sufficiunt manuefaciē aut alie
docere aues. aut cū eis uenari
cū non constet eos esse prudentes
in his si discant a uetis quisq̄

moueri poterit q̄t auem ex q̄
malo illato aut p̄ iram auis ip̄a
cū sit res debilis citissime deui-
natur. Non sic piger aut ne-
gligens. cū ars ista multoꝝ
labor est ⁊ magni studii. ille
sic gironagus ne p̄ suos mor⁹



PLATE 78.—Falconer swimming to the rescue of his bird, folio 69, Vatican MS. Pal. Lat. 1071. Note his three garments lying beside the pool. According to Frederick II, one of the necessary accomplishments of a falconer is ability to swim in order to go to the rescue of a falcon that brings down her quarry on the far side of an unfordable body of water.

Not only should the falconer keep constantly in mind the foregoing truths, lest his efforts be wasted, but it is imperative that he should also be governed in his relations with his birds by the state of their health. He must realize that in a healthy falcon her plumage, including primaries and tail feathers, is smooth. It is never rough, touseled, or misplaced, although the fine hair-like feathers lying between the cere and the eye, as well as those that constitute the beard, are held in an erect position.

When the bird is at rest the tail feathers are folded beneath the medial rudder feathers. She stands erect and steady after she has settled herself. The eyes [pupils] are round when the bird feels safe;² and the eyelids are only occasionally in motion. Whether the true lids are open or shut, the nictitating membrane, that is attached at the inner canthus, must rapidly continue its cleansing function beneath them. The wing joint—called by some the “shoulder,” by others the “propeller”³—is directed toward the head.

In health the falcon's movements are rapid, her voice is clear, not raucous, when she screams. She preens herself, including all her feathers and her claws on both sides, whether she has bathed or not, and bends her head well back to the useful oil gland over her tail. She eats with a good appetite, digests her food well, and mutes copiously and with no sibilant noise. The largest part of the normal excrement is soft and white; the dark-colored central portion of the remainder is granular and hard. The coloration may vary, however, when the bird has been fed on “washed meat”⁴ or other food, such as eggs.

The falcon's castings (of feathers) are brought up without effort, i.e., without any

² *postquam assecurat se.*

³ *Impulsum alae*, Bologna MS., fol. 44, col. 2; the Vatican Codex, fol. 70^v, col. 2, says *buctum alae*.

⁴ “Washed meat” is the falconer's term for meat soaked in water to extract its juices. It is given to reduce a falcon's weight, and acts as an internal cleanser.

shaking of the head, so that they fall directly in front of the bird—unlike those of the goshawk and the sharp-shinned hawks, who in dislodging their castings jerk their heads from side to side. In consequence, one finds the noble falcon's deposit in a compact heap; for this reason when their perches are very wide one sees them smeared with castings and mutes. The amount of excrement varies in falcons with the quantity of food or “gorges” which they have been allowed to eat.

When falcons bathe they plunge the whole head freely and quickly under water, which they beat vigorously with their wings. A falcon in good health bathes willingly and with keen enjoyment.

When the bird sleeps she stands erect on one foot and buries her head in the feathers between the shoulders. She may also do this when she is hungry.

After bating from her perch she will return a little out of breath, but not breathing painfully as if she were ill or a little too fat. Although she holds her mouth open and breathes somewhat rapidly, there is no motion of her tail, as in the heavy breathing of a bird that is ill.

CHAPTER XLIX

OF TRAINING A FALCON TO STAND ON THE FIST, AND OF OTHER STEPS IN MANNING

We have explained how the falcon is to be placed upon the fist, the position of the hand in carrying her, and how to recognize the signs of good health. The next step in training is to teach her to stand quietly upon the hand, for taming consists chiefly in persuading her to live quietly among men; and this requires frequent repetition of each step in the process.

Some authorities do not seel their falcons or make use of the hood in manning and train-

ing the falcon. Birds under these conditions become tired out and are often unable to accomplish what is expected of them. Consequently we strongly disapprove of that method.

There are two other systems of training that differ from each other in many respects, but are alike in that the newly caught bird is seeled immediately. In the first of these methods the hood is dispensed with altogether; in the second both seeling and hooding are resorted to. The first of these two plans is the older. It is slower and more difficult, and has the additional disadvantage of tiring the falcon more than the second method. Since both these systems of training are in use among us at the present time, we shall include a sufficiently full description of each to cover the training of any falcon.

Many birds are very wild and difficult to tame, especially passage falcons, whereas nestlings and many others are more obedient and easily adapt themselves to their new surroundings. The gentler the falcon when caught, the more rapidly she is trained in every respect. Our instructions will cover everything requisite for the education of the wildest and fiercest falcons obtainable. For gentler birds fewer of these precautions will be found necessary.

Let us consider first the method of manning without the use of the hood, because that is the oldest procedure. When we have learned to apply it easily, we shall discuss the use of the hood.

After the seeled falcon has been placed on the fist in the manner described, she should remain there for a long time and be carried gently about in a darkened room where she is alone with her keeper. In this state she may continue all day and the following night. If possible she should not even have relief in a change to rest on a perch or block of any kind. To accomplish this with less discomfort she should be moved from one hand to

the other, or from one man to another. If it is impossible to hold and carry her about on the fist for such a long period, she may be placed upon a block such as is described in our chapter on perches and racks.¹ Furthermore, the falcon on the first day and the following night of training must not be fed, so that on the second day (when she is quite hungry and a little less easily alarmed) she may be untied from her perch and again placed on the falconer's fist.

The falconer should now have in his pouch a chicken leg, or similar suitable portion of food as described in the chapter on the feeding of nestlings. The falcon should be carried into the darkened and quiet room where she is more easily induced to feed on this fare for the first time. If it is argued that this precaution is unnecessary since she is seeled and might well be kept and fed in a well-lighted room, our comment is that the bird's thin lids do not entirely prevent irritation of the eyes by the bright rays of the sun, so that when exposed to full daylight the falcon does not take food readily, for she is reminded by the daylight of her life in the open air. Consequently a darkened chamber is a help to appetite. So, also, is a solitary room where the bird is not disturbed by the voices and calls of men and dogs or by other unfamiliar sounds.

Falcons in training should be fed early in the day, as they are, in the wild state, accustomed to hunt for food at daybreak and if this time is allowed to pass there will not be time to feed them several times during the day; for night will close in and serving an evening meal may not be an easy task for the falconer.

The blinded falcon is taught to take food in the following manner: The meat is placed before the falcon so that the food can be smelled; then her beak, breast, and feet are touched with it. This is done to rouse the falcon so that she will snap at the object (the

¹ Cf. chapter I, p. 160.

meat or bird) that has rubbed against her. She will, as she bites the offering, be attracted by its taste and will eat part or all of it, especially as she is hungry. She will then be so eager to feed that she will not be distracted by unfamiliar sounds; and for that reason also now is the time for the falconer to make some caressing vocal appeal, encouraging her to eat. This phrase or bar of a song will serve in future, whenever she hears it, to remind her of the food she has had and will cause her to expect a meal. The nature of the sound is of no importance, but it must always be the same. When the falcon has become habituated to this call it will be found useful not only in feeding her but also in guarding her from serious disquietude. For if she is restless, either on the hand or on the block, if there is no meat at hand to give her or if the moment for doing so is inopportune, the falconer should give his call so that the bird, hearing it and therefore expecting and hoping to be fed, will soon permit any necessary adjustment of herself or of her accouterments.

At first it is not wise to allow a falcon to consume the whole of the chicken leg or other meat furnished for a meal; a certain portion should be withheld and given her in small amounts at frequent intervals during the day, always with the same familiar notes or sounds. In this way, by continually repeated gifts of titbits, the bird will gradually but quickly become attached to her keeper and grow accustomed to receive food from his hand and to be less easily disturbed by him.

The food should always be held in the hand that carries the falcon; it must, partly at least, be held beneath the three fingers that are bent under the thumb; the remainder will project between these fingers and the thumb in front of the falcon's feet. If need be, the other hand may help to hold the meat from below. If a firm grasp of the provender is not maintained, the bird in her eager efforts to swallow the food may jerk it out of the

falconer's hand and eat it too greedily, with serious results for her digestion. It is in the nature of the wild hunting bird—whose habits should as far as possible be imitated in the captive state—that she should hold her food with her talons and tear small portions of it off with her beak before swallowing it. The titbits given a falcon should be of the chicken leg or other proper food, and care should be taken lest in feeding her frequently, either at mealtime or with occasional morsels, she be given more than the proper amount. This subject we shall return to later.

While she is eating a meal in this fashion the falconer should take advantage of the opportunity to become more intimately acquainted with his bird by touching and stroking her. When her attention is held by feeding she is less likely to be frightened by such acts and on a future occasion will even permit bolder handling. His hands should be clean, so that her feathers may not become soiled when touched or stroked, since this pollution would lead to their retention of water and to rapid deterioration.

The falcon should be carried about indoors on the closed fist so that she may learn to stand firmly and fearlessly. Toward evening, before she is placed on the block for the night and while she is still on the fist, she should be fed whatever remains of her daily ration, such as has not been given her in previous smaller feedings. This will suffice her until morning so that she will sleep well and quietly on her perch. If she can be held so long and as quietly, it is much better for her to sleep on the hand all night. In this way she readily becomes used to being held and loses any dislike of standing on the fist.

The average meal should consist of the leg of a medium-sized chicken or a similar amount of other good meat. This quantity of food will suffice at first for the ordinary falcon, for it will reduce her weight a little and make her more hungry and thus easier to tame and man.

Gerfalcon and (most) sakers,¹ although they are larger than other falcons, require about the same amount of food; they are strong and lose their fat less readily, and may therefore be satisfied with a daily diet of a hen's leg.²

Tiercels and the smaller species of falcons do not need so much food, and the falconer should adjust their menu to their special needs, always keeping in mind the chicken leg as a general average.

As some meat is rich in fat and more nourishing, and some other kinds are poor and less satisfying, less may be given of the fattening meat, for it will make up in quality what is lacking in quantity. The reverse also is true.

If the newly captured brancher or passage hawk is too fleshy, her ration should be gradually diminished until her corpulence has been reduced. Owing to leanness and hunger she so longs for food that she does not shun man but looks forward to being fed at his hand.

The amount of emaciation to be secured in each instance where hunger is made a means of training the falcon cannot be determined in advance. Her daily progress should be watched and her feeding so graduated to the amount required as to insure the progressive taming of the wild bird without starving her too much; otherwise one might reduce unduly the courage, activity, and other qualities necessary in a good hunting falcon.

¹ This passage in the Bologna MS., fol. 45^r, col. 2, reads: *Girofalcis etiam et sacris quamvis sint maiores de numero falconum.* The Vatican Codex, fol. 73, col. 1, says: *Girofalcis vero plus pertinent sacris etiam quamvis sint maiores de falconum post girofalcos.*

² The Vatican Codex, fol. 73, col. 1, adds the following short paragraph: *Cum enim pusillanimes & debiles sint, non capiunt magnas aves quando sunt sylvestres sed parvas ut sturnellos et huiusmodi, vermes et lacertos, de quibus se pascunt et continent aliquando sed quod huiusmodi parum possunt habere, ita quod interdum sustinent tota die cum valde modico cibo et aliquando cum nullo et sic assueti facilius possunt esse contenti praedicto pastu scil. unius coxae galinae.* This may be one of King Manfred's minor emendations.

Excessive starvation may be detected by examining the muscles on both sides of the breastbone. This examination should be made by both eyesight and touch. The amount and prominence of the flesh deposited along either aspect of the keel of the sternum is a good indication of the general condition of the bird; so is the coloration of the flight and tail feathers. It must also be noted whether or not the colors of the beak and feet seem faded and if her movements (ruffling of her plumage, etc.) are active and lively or whether her usual acts are weak and feeble.

One should not permit undue emaciation of the falcon in training, whether induced quickly or gradually; just enough reduction in flesh is sought to produce sufficient hunger to stimulate the bird's desire to eat from the falconer's hand and to return to him when called. There are falconers who attempt, through emaciation and extreme hunger, to reduce their birds to obedience in a very short time. Others go to the other extreme. The rapidly and much-starved bird learns to hate her keeper, and should she escape she is more likely to fly off and be difficult to recapture. This is especially true when she feeds herself while in the open or remains out all night. A slow method of training is better in every respect, for the falcon develops settled habits (which become second nature) and she grows to love her master. This system is also better for the falcon's physical condition, for a sudden alteration is against avian nature but a gradual change may be beneficial.

CHAPTER L

OF THE PERCHES AND BLOCKS ON WHICH FALCONS MAY REST

It is obvious that falcons cannot be carried about all the time on the falconer's fist. The attendant must be permitted to eat and sleep, hence it is imperative that proper roosts be

provided for his charges. Not only has the falconer his usual duties to perform but the bird is, in nature, accustomed to a firmer resting place than a man's closed fist. Consequently we have at least two forms of stands—the wooden perch, frame, or rack,¹ and the stool or block.² There are two varieties of the former (i.e., high and low) but only one kind of the latter.

The elevated form of perch should be of wood, a foot wide at the top, so that when the falcon (who, in proportion to the circumference of her body, has considerable weight but short legs and shinbones) is secured with short jesses to the center of the board, she cannot hurl herself from it, either in front or behind, as she might were her jesses long or the perch narrow. Such an accident, if not promptly rectified, would injure her feathers (while she was struggling in the air) and perhaps her internal organs.³

The perch must be sufficiently high, i.e., on a level with the falconer's eyes, so that he may inspect its surface. The phlegm, castings, and mutes from the falcon can more easily be examined and an inspection of the bird's feet and jesses, which occasionally become entangled, may be more effectually made than if the perch were higher. On the other hand, it should not be too low, since the untrained hawk long retains her fear and dislike of the human face in close contact with her own, and is at first much disturbed also by the near approach of dogs and other animals that run under the perch.

The perch should be the only large article of furniture in the mews; no other stand should be placed parallel to it, either near or at a distance; if there is another one, the bird upon one perch will bate, or attempt to fly

¹ *perica*.

² *sedile seu seditorium*.

³ The curtain, or apron, of sacking suspended from the front of the high perch to allow the bating falcon to climb back easily to the top of her perch was evidently unknown to Frederick.

across to the second, and this we should always try to forestall. If there must be two perches or more in the mews, they should be entirely separated and placed along different walls; but it is best to have only one. The body of the perch should not be placed close to a wall of the chamber lest the falcon when shaking herself scrape the partition and so damage her wings. The rack should stand firmly on all four feet lest its rocking be a cause of disturbance to the bird.

The perch should be portable, for it is desirable to change its position from time to time. While she is still wild and untrained, the falcon's perch should be placed in the darkened room far from the window; when she is tame and can be kept in lighter quarters, the perch may be stationary and the light and air in the room regulated by opening windows or closing them when necessary. The entry of smoke or other foul air should be prevented. The high perch may be long or short, depending upon the space that is available.

The low perch may be made of either round or squared wood (*lignea rotunda aut quadrata*) and must be so raised from the ground that the tail feathers of a falcon perched thereon do not touch the earth. The length of the perch is of no importance, but if there are several of them the rules applicable to the high racks should be followed for the low ones.

The stool or block can be made of wood or stone; its broad upper surface should be round, flat, and smooth, and the lower part should taper to a point so that the whole structure makes what the geometricians call a (an inverted) pyramid. At the point of the block should be inserted a sharp iron spike, as long as a man's palm, either round or square, and of the thickness of one's thumb, that can easily be driven into the earth to make a firm foundation for the stool. The height of the block above the ground should be the same

as that of the low perch. There must also be placed on the ground, around the stool, but not forming part of it, a wooden or metal hoop. The iron spike of the pyramid is thrust into the ground within this hoop. The falcon's leash is tied to this ring in such a manner that when the leash is pulled or jerked by the bird, it slides round the circle and does not impede the movements of the falcon either on or off the perch. This hoop is always carried about with the stool. When there are several of these stools in the mews, they should be kept well separated in order that their occupants may not touch each other.

Although stools of stone are sometimes quadrangular, they are not suitable, because when a falcon flies off her stand it may happen that the leash will catch on a corner of the stone or, again, her flight or tail feathers may be injured in an attempt to bate. Moreover, after a bath the wet quills of the wings are easily cut (or deeply scratched) if they are scraped on the sharp corners of such a stool; nor can the bird be as readily fastened to the round hoop of a four-cornered stool as to that of a circular one. It is in some cases necessary to insert a wooden peg in the floor near the stone block, to which the leash can be attached. Finally, it is not as easy to transport from place to place a heavy stone block as it is to carry the wooden pyramid.

Every stool or perch should be placed (both indoors and out) near a wall well out of the path of men and domestic animals but not so close to it that in bating the bird strikes her wings against it. Beneath the low perches and around stools, straw, grass, or sand should be spread so that when the falcon springs to the ground she does not abrade the soles of her feet, nor injure the ends of her quill feathers.

This completes our description of perches for falcons. Stands for hawks will be discussed later in their proper place.

CHAPTER LI

OF THE USE OF VARIOUS STOOLS AND PERCHES

The high perch is more useful than the low one because more falcons can roost on it and this type of perch does not cramp the space in the mews as do lower roosts. Moreover, when on her lofty perch a falcon is not so much afraid of men or household animals, and the approach of dogs or pigs (in the absence of attendants) alarms her less than if she were placed on a low stool, for they cannot reach up and harm her while they can pass under the high perch. For this reason the taller stand is much to be preferred to either the low perch or stool for the partially blinded, the recently seeled, and all wild birds.

For the completely ciliated falcon the high perch has no advantage over the low one, or the block, because on the former she can more easily entangle her jesses and thus damage her quill feathers. Blocks and low perches are better for totally seeled falcons, because sometimes they are trapped, or trap themselves, by inserting a mandible into the slit of a bell. Then in the struggle for freedom they may hang themselves from their high perch and be seriously injured. Such an accident cannot occur with a low perch or block. From the low stool a falcon can always reach the earth, stand upright, rest herself, and not be in danger of suspension in the air for a long period. Moreover, the long leash attached to the stool or low perch cannot be easily twisted or disarranged. If the falconer is obliged to be absent for several hours, he can safely close the shutters of the mews and leave the bird on the low perch. The latter is better than the single block because it can be made long enough to accommodate a number of falcons; the stool holds but a single bird.

In one respect, however, the block is safer

than either form of rack; i.e., when roosting in company with other birds, a falcon is less subject to assault by them. Even when there is only one bird on a perch, she is in greater danger on either perch than on the stool, because the rack is long and permits her to bate from side to side and in doing so she may strike her body or damage her wings. She is less exposed to this sort of harm on the stool, as the free space about her is in her favor.

It is evident that the requirements for tying the falcon to the various forms of roost are not always the same for partially and completely seeled falcons or for perch and stool. Entirely blinded falcons may without distinction rest satisfactorily on any form of perch or block; since they cannot see anything at all they are not likely to be affected by visual irritants that usually lead to restlessness and a desire to fly off the roost.

The falcon should be placed on the high perch and fastened in the following manner: Pass the leash through the rings of both jesses and knot it as directed in our chapter on the leash.¹ When about to place the falcon on the perch her face and breast should not be directed toward it, for as she cannot see whither she is headed she will not mount the perch even though her breast touch it. But the falconer should carry his hand bearing the captive raised in front of and higher than the perch itself. Then he must gradually lower his fist in such a way that the tail and abdomen of the bird are well over the roost and the lower leg and back of the knee joint (along with the hand of the falconer) are barely touching the perch; then let him release the jesses from between his fingers. The blind bird will voluntarily step back on to the perch from this position.

While the fist carrying the bird is employed in this manner, the other hand should

pick up both ends of the leash, pass one to either side of the perch, gather them together below the rack, and draw them downward until the knot holding the rings of the jesses rests at the midpoint of the upper side of the perch. The hand bearing the falcon can then be withdrawn and she will readily move from the falconer's fist to the perch proper. The longer portion of the leash may be wound round the pole (or upper platform) of the perch so that it may be tied below to the shorter end, but with a knot that is quickly loosened. One makes two turns of the leash about the perch in this fashion so that the attachment of the jesses is held firmly in the center of the platform and does not slip back and forth; then, if the falcon bates, she can more easily and without injury resume her proper stance.

When the falcon is properly installed in this manner on her high perch, the falconer can leave her, moving quietly and making sure that she is not likely to become restless or be seriously disturbed by strange noises in her neighborhood.

When the falconer wishes to settle the seeled bird on a low perch,² he proceeds as follows: He passes the long leash through the rings of the jesses to the button at its end, but he does not tie the rings together as on the high perch; next he bends his knee on the side opposite the hand that holds the falcon and, with his free hand, draws the long, unknotted end of the leash around the perch, leaving about a foot and a half of the leash free at the end attached to the jesses. Then he ties the leash to the perch, so that by pulling on the free end the knot is easily loosened. Next, he places the hand holding

² In the Bologna Codex, fol. 48, the Emperor describes, first, the movements of the falconer when placing the bird on a high perch, then on the block, and, finally, on the low perch. In the Vatican manuscript (revised by King Manfred) the passage is rearranged to treat the perches in their more rational order; and this reading we follow here.

¹ Book II, chapter xxxix, p. 140.

the falcon in such a position that the bird's legs touch the roost and her belly and tail are above the perch. When this is done she will step backward on to the perch—a method the blinded bird prefers to that of facing the perch with her breast. Finally, the falconer releases the bird's jesses, allows her to stand upright on the rack, rises quietly from his knee, and leaves her all to herself without delay.

When the falconer desires to place the seeled bird on a block, the leash is pushed through the rings of the jesses to the button at its end, but it is not tied to them (just as described when speaking of the low perch). With the falcon on his fist the falconer now approaches the block, bends his knee, and ties the leash to the hoop at the base of the stool, leaving the same length free as when tying her to the low perch. He then places the falcon on the block in the same manner as on the high perch. Then he stands up and leaves her alone.

Although we have said that the seeled falcon may be placed on any of the three forms of roost, the block is on the whole the safest rest for her. The three perches are to be used alike in several respects; a seeled falcon may be placed on any one of them and she is made to move backward on to them all. Their use differs in that the leash of the high perch is tied very short but is left a foot and a half long on the stool and low perch. Also, while only one falcon can rest on a block, several may be accommodated on each of the other forms of stand.

When a number of falcons are set on a high perch, they should be disposed as follows: After one falcon has been tied in the manner described, a second bird of the same or of a closely related species may be placed on the perch at such a distance that they cannot touch and harm each other, with either their beaks or their outspread wings. The number of falcons that may be placed upon

one high perch will, of course, vary with the length of the perch and the size of the falcons.

In arranging falcons on a low perch the first two birds should be placed at a proper distance from one another and the knots of the two leashes should be tied close together about the perch. The third bird should be so stationed that neither with her wings nor with her beak can she touch either of the other two. A fourth falcon should be placed in the same position with reference to the third, as the second stands in relation to the first. Thus the whole length of the perch will be fully occupied by falcons arranged in pairs. In other words, on the high perch each falcon is held in position independently of the others and with a shortened leash, whereas on the low stand the birds are arranged two by two with leashes that are left longer than those of the falcons roosting on the high perches.

The reason for arranging thus intimately the knots of each pair of falcons on the low perch is that, were the birds tied at equal distances along the perch the falcons might (since the leashes are left a foot and a half long) in bating change positions and allow their leashes to become entangled, with dire results to both birds. On the other hand, when the leashes are knotted close together on the perch, even though they become crossed, the intersection will be drawn close to the perch, leaving the falcons free and unharmed. Should it be desirable, by any chance, to tie several falcons upon a low perch and separated one from another, they should be placed so far apart that in bating they cannot cross or touch each other. However, if it is possible to arrange them in pairs, the perch or rack can be made to accommodate more birds. In short, on the low perch birds must be tied so far apart that they cannot possibly injure each other, or else in pairs in such manner that their leashes cannot become entangled.

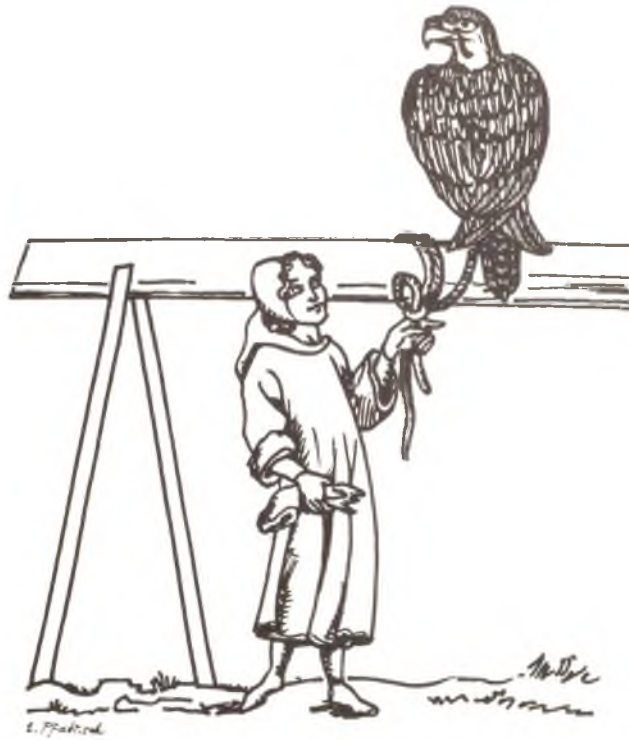

PLATE 79.—(Above) The high perch (*pertica alta*) placed at the level of the assistant's eyes; the falcon is tied to the perch with a falconer's knot (after Charvay). (Below) Recently captured falcon wrapped in a sock (*maleolus*) so that she can be handled without a struggle. The second figure depicts the operation of seeling (temporary blinding) the imprisoned bird. (Drawing after Charvay, who took his designs from the French translation of the *De Arte Venandi cum Avibus* (Bibliothèque Nationale MS. Fr. 12400))



PLATE 80.—(Above) Spraying the falcon. When the restless falcon could not be quieted by offerings of food morsels, an effective remedy was sprinkling her with cold water, squirting the fluid (after cleansing the mouth) gently and in a fine stream over her breast and under her wings. This was a favorite method of the Emperor. (Below) Handling and feeding the falcon. As is repeatedly enjoined in the *De Arte Venandi*, no one in her immediate vicinity should stare at the captive falcon, who is easily alarmed by even a passing view of the human countenance. This rule is illustrated by both these figures: in which the falconer (1) feeds his bird from above the latter's head, and (2) turns his back when replacing her on her perch. (After Charavay.)



E. Pfadtisch



E. Pfadtisch

PLATE 81.—(Above) Block perch for hacking falcons—one of the numerous forms.
(Below) Bow perch for hawks.



PLATE 82.—The lanner (after Gould)

CHAPTER LII

OF THE UNREST AND BATING OF
SEELED FALCONS

After the seeled falcon has been properly placed on her perch and left there to rest and sleep, the falconer must look in on her from time to time, because the wild bird, knowing that she is a captive, instinctively makes frequent efforts to fly away and regain her lost freedom—hence her restlessness and attempts to fly off her perch.¹ The term “restlessness”² covers all those tiresome acts and movements made by falcons that are not included under bating,³ i.e., the efforts of a falcon while retained by her jesses and leash to fly from the hand or perch.

It may further be said of bating that the sighted wild falcon is usually the one most addicted to this habit, and in these attempts to regain her lost freedom she may seriously harm herself—a subject we shall further discuss when speaking of unseeled falcons.

The seeled falcon indicates her unrest, which may be the cause of many self-inflicted injuries, by several signs, whether on the perch or on the falconer's fist. Sometimes she bites her jesses and bell, or the glove of the person carrying her; or she scratches her head, particularly those ocular parts affected by the seeling. She also turns about on her perch, so that her feet become snared in her jesses, or she violently flaps her wings.

The reason she bites her jesses, her bell, or her master's glove is that she is not yet accustomed to these impediments on her feet, nor to standing on the glove, and wishes to

¹ In English the falconer calls this “to bate,” or “bating.” It includes the springing, or flying, of the falcon not only from a perch but also from the fist of the falconer in an attempt to regain her liberty.

² *Inquietationem dicimus omnem illam defatigationem quam facit falcon non conando recedere ad volandum* (Bologna MS., fol. 48^v, col. 2).

³ *Diverberare vero dicimus quando de manu vel sede sua conatur recedere ad volandum* (*Ibid.*).

be rid of them. Biting her jesses only tightens them and injures her feet (especially when she also nips her toes and shins) and tires her out. Now and then she inserts her beak in the slit of her bell if the opening has been made too wide. To prevent these accidents one may tie a fragment of tile, wood, or stone over her mandibles, so that she soon becomes discouraged and desists from these harmful practices. Also one should examine the apertures in the bird's bells and make certain that they are not too large.

The falcon may also try to scratch off the seeling threads from her eyes not only because she wishes to see about her but because the eyelids are painful and itchy. Unfortunately it sometimes happens that in these efforts a falcon thrusts a talon between the sutures and the eyeball. If she does this she may succeed in breaking the seeling threads or in lacerating the parts in and around the eyelid.

Of course not every falcon is subject to these tantrums. When decided unrest is observed, the toes (called the thumbs) are tied together with a strip of leather but at a distance apart of three fingerbreadths more or less according to the size of the bird. When this is done, it is impossible for the falcon to lift her foot to the sutures.

The falcon may turn about to change her position and so twist her jesses that they become entangled with her claws and talons and she is unable to stand upright. If this happens she may fall off her perch and not only suffer from an inflammation of the injured feet but seriously damage her flight feathers and other parts of her body. This form of unrest on the part of the falcon may be relieved, and subsequent mischief prevented, if the falconer will carefully accommodate his position and that of the hand bearing the bird to the latter's restless changes of position on his fist; and he should choose as her roost a low perch or, better, a block. In the latter position, owing to the lengthened tether, she

will not be able to dislocate her jesses so easily; moreover, in this position she will have a feeling of greater liberty. If, however, the falconer prefers to carry the unquiet falcon on his fist, he should straighten out the twisted jesses with his unoccupied hand and, if necessary, offer the bird a bit of the reserve meat carried in his pouch, holding it high up for the restless falcon to bite into.

Inasmuch as the falconer cannot usually give all his time to watching a particular bird, he may attach the leash to her jesses by means of a swivel and tie her so close to the perch that she is prevented from crossing beyond either side of the perch in her attempts to bate. If this device is not used, the attendant should inspect the falcon frequently to make sure that her jesses are not displaced and that she is not biting them or scratching the sutures in her eyelids.

When the falcon thrashes about with her wings, it is a sign that she desires to fly but does not bate from her perch because she is aware of her tethered condition. This sign is often noticeable in young birds that are still in the nest, or in those fledglings being raised in the mews before they have learned to fly. For though they desire to use their wings in flight, they are afraid to make the attempt. Hence it is our opinion that the beating of wings (in grown falcons) arises from the desire to fly, though the bird is well aware of her inability to do so. This peculiar unrest and thrashing about of the captive falcon is not dangerous but may lead to bating. Therefore if the falconer believes that the falcon's flapping of her wings is a preliminary to springing off her roost, he must unloose and place her on his fist, where her unrest and flying off are less dangerous. In that situation evil consequences can more easily be avoided and the bird be kept more under control.

If the falcon continues to beat her wings and to make efforts to fly away, she can some-

times be quieted by calling or speaking to her; if that fails, try her with a cold wing (of chicken) or other "tiring." When the unruly bird becomes overheated and does not respond to any of the remedies just suggested, she should be sprinkled with cold water or invited to take a bath, a procedure that will be described in the chapter on the training of sighted falcons.

CHAPTER LIII

OF THE TRAINING OF THE SEELED FALCON THROUGH THE SENSES OF TASTE, HEARING, AND TOUCH

The methods already mentioned for taming a falcon—among them daily petting, i.e., offerings of food and getting her accustomed to a gentle stroking of the mandibles, breast, wings, tail, and feet—are fundamental measures, to be carried out for several days in a darkened and isolated room, until she takes her food eagerly and begins to be more docile. Then she may be brought into a better-lighted room, with doors and windows open, frequented by other men talking among themselves, dogs, etc., to all of which she must eventually accustom herself. Meanwhile, as in the darkened mews, this feeding and stroking of the bird should be kept up until she is fully habituated to being fed and handled. And this treatment should be continued for a number of days.

As soon as the falcon learns to take her food properly she should be familiarized with the usual noises and din of the neighborhood, such as are made by people about her, so that in the future she may not be disturbed by them. To this end she should be carried into various parts of the house both by night and by day and, while hearing the sounds about her, she will yet learn to rest quietly on the

fist. She should be treated in this manner until the falconer feels sure that she is entirely at home on the hand, is willing to be touched, is eating with a good appetite, and hears unfamiliar sounds and noises with no sense of alarm.

It is now clear how the falcon is tamed by the sense of taste to take food (against her normal instincts) from the hand of man; and how, through the satisfaction of her desire for food, she will permit herself to be handled by man, whose touch is normally abhorrent to her. By means of these two senses she is finally trained to tolerate unaccustomed sounds.

All this should be taught the falcon before she is allowed the use of her eyes. It is difficult to train at the same time all the falcon's senses, including that of eyesight, without prejudice to the status of the bird as a first-class hunter.

There are those who irrationally inquire why, if it is necessary to blind the falcon, so that she may not see unaccustomed and disturbing sights, it would not be desirable also to plug her ears so that she may not hear alarming sounds that frighten and cause her to be restless? The fact is that the wild falcon learns largely through the sense of taste to disregard unusual impressions perceived by her other senses. The soothing and quieting tones of her attendant, heard while she is being fed, she remembers as an invitation to a meal, and to make this effective her ears must not be closed but the sense of hearing educated. She learns to recognize and to become reconciled to the voices of human beings more readily than to the sight of their faces or of strange unfamiliar indoor objects, or to being touched by and touching unknown objects that she probably believes may injure her. What the blinded bird hears does not give her the same premonition of danger as what she sees or even what she feels.

For all these reasons the falcon is to be

trained by the three senses of taste, hearing, and touch before she is sighted.

[*Addition by King Manfred:*¹

The chief aim of the falconer should be to train his hunting bird to make use of all her faculties in his presence without any sense of terror. To this end he must endeavor to eliminate any fear of objects and persons aroused by that sense most likely to occasion it, viz., sight.

Freedom to hear sounds and to feel objects is, in this scheme, of less importance because these senses are under control, or modified to some extent by means of diet regulation. This is not true in the case of sight, because terror caused by what she sees overpowers any pleasure a falcon may take in tasting some delicacy.

Closing the ears will fail to accomplish the aim of the falconer because, when hearing is restored, the falcon is as untamed as before and the falconer will have failed in his attempt to win the confidence of his bird.]

CHAPTER LIV

ON THE TAMING OF FALCONS BY THE GRADUAL RESTORATION OF EYESIGHT

All the senses of the wild falcon must be trained gradually to tolerate strange sensations; but since the disclosures of vision are much more hateful to the bird than the revelations of taste, feeling, or hearing, eyesight must be disciplined—generally by slower degrees.

When the time arrives for restoration of her sight, the falcon ought not to be disturbed by an abrupt view of strange objects. She would then be upset not only by what she sees but by what she perceives through her other senses, and would become wilder than before. Were we to attempt by a sudden exposure of

¹ Vatican Codex, fol. 80.

the bird's eyesight to tame her, or to tame her without seeling, our aim would be accomplished not by skill but by the exhaustion of the falcon through her efforts to grow accustomed to her new surroundings in a very short time; and these attempts might lead to her permanent disablement. Therefore a return to the use of the eyes should never be sudden but must be made gradually.

The partial unseeling of a falcon can be accomplished by seizing the bird about her shoulders and holding her as in the operation for ciliation. If the perforations made through the eyelids by the needle are not inflamed and pus has not formed, so that there is no danger of the threads cutting through the palpebral tissues (before the time arrives for her to be fully sighted), the knots in the ends of the sutures placed over the head after the operation of seeling can be untied and new knots made and so placed that the lower lid margins are allowed to descend to the center of the eye. The head feathers should then be readjusted over the new knots. If, however, the stitches made by the needle are so infected that they cannot be relied upon to hold the lower lid firmly in place, they must be withdrawn, or cut away, and fresh ligatures introduced at new points.

This procedure should be carried out at night, or in a darkened room where few people are present; and the falcon must be permitted to grow slowly accustomed to a recovery of eyesight. She should not be allowed to see the face of her attendant, nor to perceive plainly other objects in her immediate neighborhood; and she should be frightened as little as possible. During this gradual restoration of her vision she must be habituated, as a preliminary, to seeing everything indistinctly, including the attendant's face and the movements of his hands when they touch her. From now on, the falconer may more easily touch or handle the bird without unduly alarming her.

Whatever light she sees will come from above her. If she then attempts to bate it will be upward and not down, since she sees no objects beneath her. Looking up is a good habit and should be encouraged, because while on the fist she will look upward and therefore stand more erect.

After this partial restoration of her eyesight the falcon should be carried about for a day and a night on the fist, and always indoors, before she is replaced on the perch. Food should be given her at intervals and in small quantities—including the tiring—and she should be gently stroked and allowed to become accustomed to various sounds as when she was fully blinded. After several days of this treatment she should be carried into a brighter room in which there are other men. This practice ought to be continued for another period, when she must be introduced to a still better-lighted chamber where, though she sees men indistinctly, she can hear everything and may even allow herself to be gently handled.

As previously stated, some falcons are much more amenable to this sort of treatment and are sooner tamed than other birds who are naturally wilder and, in consequence, require additional days of patient attention.

When it is noticed that the half-seeled falcon is not alarmed when carried about either in a dark or a lighted room, she should be borne on the fist outdoors into the fresh air, her carrier being first on foot and then on horseback. When this is to be done the falconer should rise before daylight, take the bird from her perch, and carry her carefully out of doors. As she passes through the doors of the mews, both on her way out and on her return, the trainer must observe certain definite rules of which we shall speak a little later.

After the falconer has followed these instructions for several days on foot, he should accustom the falcon to being carried about on

horseback, also before daybreak. Let him take his falcon and, having mounted his horse, carry the bird about (at first near the mews) and not stay out too long; he ought to return while it is still dark. Later on, he may linger until sunrise. The precautions to be taken by the falconer in mounting and dismounting his horse¹ will be described under the training of completely sighted birds. The half-seeled falcon is not so inclined to bate or to be wild as one who has been allowed her full vision.

The falconer should keep the half-sighted bird on a high perch. It is more satisfactory than the low perch or block, inasmuch as the falcon, when placed on one of the latter, seeing objects but dimly, is more likely to be alarmed by persons approaching her. Because of her half-restored sight she may not remain quiet while being tied to any perch. The falconer should give her the tiring while he is performing this operation and take it from her when she has been placed in position. In putting her on the roost she should be held with her head and breast facing the perch; for, since she can then see and recognize it, she is ready to leave the falconer's fist and mount the stand. The instructions about tying one or more seeled falcons to the high perch apply also to half-sighted birds.

In the absence of a high perch the bird may be placed on a low one, or on a block, in which instance the leash must be lengthened and greater freedom permitted; also the falcon must be more carefully watched while on a low perch.

The remedies available for relieving the falcon's fits of unrest have already been discussed in a previous chapter. The causes of bating, how it is to be avoided (and treated when present), and the removal from the perch of a half-seeled falcon are fully discussed in those sections dealing with the training of fully sighted birds.²

¹ Book II, chapter lxxi, p. 194.

² Book II, chapters lvi-lx, pp. 175-84.

CHAPTER LV

OF THE MANNING OF SIGHTED FALCONS

When the half-sighted falcon has been well exercised on the fist and tamed in the mews and outdoors (on foot and on horseback), her full vision may be restored and the bird further educated so that she can see objects plainly without becoming wild again.

On the day selected for that purpose the falcon should be fed only a portion of her early morning meal. The reserved portion is given her with other fresh meat at night, immediately upon being unseeled and before she is put on her perch.

The falcon must not be unseeled in daylight, for should she see suddenly and clearly the faces of men and other objects to which she has not as yet been accustomed she might become terrified and so seriously disturbed that she would make excessive efforts to escape, tire herself out, and even become ill. Moreover, if frightened then she would in future be even more likely to dislike men—whom she would blame for her troubles—and might suffer such a relapse into her feral condition that it would take a long time to tame her.

The eyelids that have been held in an elevated position for some time resume only gradually their normal position, hence if the falcon is unseeled at night she does not become alarmed, for at first she perceives objects about her as through a mist and grows familiar with them as their images become clearer.

Unseeling must be performed by candlelight. The falcon is taken in both hands of an assistant, as in seeling; the knot of the seeling thread is untied, or the suture cut, and all traces of the ciliation are as far as possible removed. The light employed in this work is carried away at once (lest the bird, frightened by something she sees, attempt to bate with

dire results) and the falcon placed upright on the attendant's fist. The familiar call notes that the falconer speaks to his bird, especially when feeding her, are now frequently repeated, and the remains of the morning meal are given her. If the bird accepts the offered food and eats it as usual, the candle may be brought back but not allowed to shine on the falcon as brightly as during the operation. The room should be made lighter little by little. The candle may even be allowed to remain in the mews all night, so that the furniture is visible. In this way, as morning comes, her surroundings will be familiar to the falcon, since she will remember seeing them during the night. The falcon will be surprised by and reminded of old and alarming experiences, since forgotten, if the room is suddenly flooded with bright sunlight. The attendant must be more vigilant than on previous nights and must carry her around the mews before he puts her back on the perch. As her eyelids are lowered to their normal position, the bird will see her attendant's face and other surroundings, and her visual perceptions on the following day will be simply a continuation of those received at night.

If while the recently sighted falcon is thus carried about she becomes frightened, or bates, she should be soothed by the falconer's voice and the emergency ration (*tiratorium*) offered her; and when her fright has passed she will cling more firmly to the fist. Now the ration should be taken from her, as it is not wise to make too frequent use of this stratagem. At this juncture the bird should be permitted to rest upon her perch, but well before daylight the falconer should again take her about on his fist.

The so-called "emergency ration," or tiring, is of the greatest assistance in taming falcons (especially when this is done without the hood), because it is the chief means of rousing in the bird affection for her master. We shall now describe it. It consists of the

leg (or wing) of a bird or other animal which the attendant gives the falcon to keep her quiet. There are two kinds of this meal. The first is the fresh and plump leg, plucked wing, or neck of a hen or other bird (or some suitable fresh meat). The hungry falcon will take the tiring of this food and, in her enjoyment of its flavor, will desist from her restless behavior. The second form of tiring, the "cold wing" of a fowl with its tendons, bones, and all the feathers unplucked, is to be given the falcon that she may be quieted while she occupies herself in pulling and tearing it. The first viand is a tasty trifle of food, while the latter acts more as a casting (as will be explained in the treatise on disease).⁸ Familiarity with and affection for human beings and endurance of strange faces are promoted by these gifts. Consequently the falconer either carries them in his hand or keeps them in his pouch for immediate use—to be employed, however, only when need for one or other of them arises. At the same time he should speak to the bird with his usual familiar tones and phrases but should not look directly at her either before or in giving her the tiring.

With one hand the falconer should place the ration in front of the bird's feet and hold it with one or both hands, just as in feeding her indoors. While her attention is fixed on these titbits, the falconer should take the opportunity to investigate the causes of her restlessness and remove them at once. The food is taken away after she has eaten a little, or just as soon as the cause of her fright has been forgotten. She should not be gorged, for she might later refuse the proffered emergency ration when it was desirable to use it.

Through the use of the tiring the falcon's sense of fear is reduced. Also, were she not familiar with it, at a time when she is excessively frightened she would not recognize it and, in consequence, having no desire for it, would refuse it. The falconer would then

⁸ Either not written or lost.

have no means of quieting her [except the use of the hood, of which we shall speak later].⁴ Her regular rations, as well as the emergency ration, should be offered the bird from above and close to the face of the falconer, so that she may grow used to seeing him.

On the night when she is granted full vision, the falconer must not wait until sunrise before taking the bird from her perch; she must be on his fist before dawn. In this way the visual images perceived at night are continuous with those of daylight and, as the falcon's eyes open fully and the sun rises, she gradually and with an increased sense of security gazes on the countenance of man and other objects. It must be repeated that she should never be carried from a darkened room (or one lighted only by a lantern) into full sunlight. Care should be exercised in this respect, and the bird should be carried about a room only where the light is equivalent to that created at night by a lantern. The light may then be gradually increased; how quickly will depend upon the wildness of the falcon. Inasmuch as the bird with her vision restored sees human faces and other things as plainly as she ever did, and since it is natural for her to move about more during the day than she does at night, she is more likely to be restless when confined during daylight hours and at that time to be more easily irritated and more likely to bate.

CHAPTER LVI

OF VARIOUS FORMS OF BATING¹

We have distinguished between restlessness and bating, and have described the unrest of captive birds and the remedial measures advised to prevent it. It is now in order to

⁴ These words in brackets are omitted in the Bologna Codex, fol. 52, col. 2.

speak about the evils of bating, in which the sighted² falcon may energetically indulge and always with more serious danger of injurious consequences than in the case of either blinded or half-seed birds. At times she may try to fly off the carrier's hand, from her perch or stool, or even from the closed fist of the horseman.

We must consider every form and degree of this vice and point out the most reprehensible of them, and show how the falcon may best be induced to indulge in only the least harmful. We must also explain how she is to be replaced on the fist of her master. It is also quite important to discover the cause of each outbreak and to note its signs and symptoms both before and after the act. If the falconer cannot prevent the attack when its symptoms are first noticed, he must soothe the restless bird, lest she injure her feathers and thus become useless for the service to be required of her after she is manned.

We call it bating when the falcon, held by jesses on the hand or perch, attempts to fly off. This occurs most frequently in unseeded falcons held on the hand and indoors during the period of their wildness.

There are various forms of bating. For instance, a falcon on the hand will sometimes fly toward the face of her bearer with the intention of passing upward over his head. This she seldom does when first captured but will do more frequently as she grows familiar with his appearance. She may also bate along his arm toward his shoulder, or in the opposite direction, away from his face and over the end of the hand. This last form of bating may be upward, downward, or directly outward. She may attempt to fly from one hand

¹ The Bologna MS., fol. 52^v, has no break at this point for a new paragraph or chapter. For convenience we follow the Vatican Codex.

² Both the Bologna and Vatican texts omit the word *deciliatus*. For the sake of clarity we follow Velser (p. 265), where it is supplied.

to the other, i.e., from one side of the falconer to the other. This, too, may be in three directions—upward, downward, and straight across. [At times the falcon may bate backward in the same three fashions.]⁸

As some forms of bating are more serious than others, let us see which is the least harmful; for though we cannot altogether prevent the falcon from flying off the hand, we can train her to choose the least injurious acts.

Flying in the direction of the falconer's face is least harmful because the falcon must mount above the man's head, and so can be retrieved readily by the hand; for, as the falcon is heavy and every weighty object when lifted seeks a lower level, she is easily brought down to the hand beneath her. Moreover, neither her body nor her feathers suffer injury in this instance, nor will she be greatly fatigued.

Bating from one side to another, or from one hand to the other, is more fraught with danger; and it may be performed in various ways. In a falcon accustomed to be carried on one hand only, the habit of bating in this fashion is especially dangerous if perchance she has been transferred to the other hand. Because in the new position she will bate backward, off the hand, in order to move in the direction of her usual spring. This renders it difficult to replace her except in a round-about manner. Nevertheless, bating from one hand to another has one good feature—the falcon may be recovered easily and drawn back into position by the hand upon which she was standing.

Bating toward the shoulder is a serious act because, when the falcon flies off the fist, her tail is bent beneath her and, as she is drawn back to the hand, it strikes violently against the index finger (bent over the thumb) and is thus trapped between the body

of the bird and the falconer's fist and may be seriously injured.

Springing along and away from the fist in various directions and fashions is deleterious because the falcon must turn and twist before she can be brought from the inner side of the hand into her former standing position.

Bating behind the fist, in any of the directions described, is also disastrous because the bird is reinstated only with great difficulty from her lowered position. Before she can be replaced properly upon the fist she must be turned about and brought to the inner side of the hand. The reinstatement of the falcon in this case, owing to the longer course she must take, consumes considerable time, and while the falconer is trying to restore the bird she must hang down from behind his hand.

In all cases of bating the falconer must use every effort to replace the falcon as quickly as possible in her normal position, for the longer she is pendant the greater is the risk of serious injury.

Of the three motions in all the forms of bating just described, the straight outward and the downward movements are more perilous than an upward one, because in the last instance the bird can more easily be caught and returned to her former stance. The downward movement is the most dangerous, since the weight of the hanging falcon adds to the difficulty of drawing her up and replacing her on her feet. Bating straight outward is less injurious than the foregoing, as the bird is not suspended by the feet while she is being reinstated. It is, however, not so satisfactory as an upward movement, where her weight is of assistance in drawing her down into position. From the foregoing it will be clear that the most objectionable of all forms of bating is the backward and downward movement.

Inasmuch as a falcon that is securely held on the fist or tied to a perch will not remain quiet under all conditions, especially while

⁸ This sentence is not given in the Bologna Codex, fol. 52^v, col. 2, but is added in the Vatican MS., fol. 82, col. 2.

still in the wild state, it is good policy to accustom her to that form of bating that will do her least harm, viz., that which takes an upward direction toward the falconer's face. With this in mind, we shall describe various ways of training a falcon to fly upward over the attendant's head. To begin with, the attendant in offering the bird food (either as a tiring or otherwise) should remember to hold it high before his face, so that she will bate upward to reach it. Then there is a second maneuver that may be employed when about to place the falcon on the high perch. The attendant turns his back to the roost, placing his body between it and the falcon. He then brings the hand on which she stands toward his chest. In this way, the bird, seeing the perch and attempting to reach it, bates over the falconer's head. This scheme is useful when employed for the high perch, the latter being above the head of the falconer. But if the perch is on the same level, or lower, the attendant must stoop to bring his head below the platform of the rack.

These precautions should be practiced quite frequently during the day, but not often enough to fatigue the bird. There is still another means that may be employed to accustom the falcon to bate toward the head of the falconer. When the captive bird is on the fist indoors and is taken into a lighted room, the falconer should keep his back toward the windows or any other sources of illumination. The bird in bating will naturally spring toward these lights and, in consequence, toward her attendant. In carrying out these three schemes to encourage upward bating, the falconer should help the bird by following her upward movement with his hand; for if he holds the carrying hand too tight or very rigid, he may easily injure her kidneys and hips.

The following is yet another means whereby the falcon may be taught to bate upward. If there are several windows in the mews,

one should be selected that is higher than the perch, and the others darkened. The falcon on her roost, be it perch or stool, should then be placed in front of the single, lighted window, with her face toward it. If she bates, trying to reach the open air, she will spring upward toward the light. Even though she does not bate, she will stand erect on her feet and have no desire to bate in any other direction. In this way it becomes second nature for the falcon to spring upward even in other forms of bating, thus rendering them less harmful.

If the falcon bates toward the attendant's shoulder, the falconer should bend his arm and hand toward his face and pull her back (by her jesses), as when she bates over his head. If she springs outward, away from the fist, the falconer can draw his hand back and turn it so that she is at his other side and thus quickly restore her to her proper place. When the bating off the fist is toward the opposite hand, the falconer must follow the bird with his carrying hand and quickly but gently readjust her stance. If the falcon springs upward, she should be followed with the fist and gently pulled back by her jesses; she will then be likely to resume her former position on the hand. If she springs straight outward, the fist should be lowered. The falcon, finding it directly under her, will be more easily drawn back into place. If, however, she bates downward, she must be followed by the hand and raised up a little, after which the falconer must hold his free hand below the bird and replace her on the fist as soon as possible. It must be remembered that any delay in executing these maneuvers is hurtful and full of danger to the welfare of the falcon.

A remedy for some of these misadventures is to learn to carry the falcon alternately on either hand, so that the bird will accustom herself to fly directly from one hand to the other and not to bate (disastrously) to the rear of the fist.

CHAPTER LVII

ON THE CAUSES OF BATING

Indoors a recently sighted falcon bates from the fist for many reasons. She may become frightened, not only by the falconer himself but by objects that she notices about him, as well as by phenomena that she observes for the first time. We cannot dispense with the falconer who trains her, nor with some of the furniture of the mews; but it is possible for the falconer to prevent the approach of other sources of indoor alarm that worry the newly sighted bird. We shall therefore first discuss bating caused by the presence and movements of the falconer; for when this has been overcome, the falcon may be gradually inured to other disturbing agents. To do both at once would be too great a task.

In our discussion of bating we have in mind for the most part the passage falcon and in less degree the brancher. Bating in nestlings is much less frequent and not so hazardous, especially when the falconer stands by ready to help the youngsters; but it is more hurtful in birds that have been captured when full grown. The brancher or passage falcon, when first unseeled, is naturally wild and fearful, especially since with the coming of daylight she sees in man much that induces a desire to bate. The entire person of the man holding and carrying her (which she has not heretofore clearly observed, especially his face) is dreadful to her as to all other animals. They all appear to realize the saying, "the face of man is the lion's face." The sighted falcon remembers the time when she was captured by man and is terror-stricken by the appearance of a human being. Every falcon is alarmed and disquieted by that well-remembered visage until she has been (gradually) sighted and has become accustomed to it. A sudden exposure to the human visage without seeling, or the protection of a hood, is a practice we have already denounced.

In addition to the alarming appearance of the human countenance, views of the falconer's arms, when he touches the captive bird, are disquieting, as, indeed, are all such movements as are required in speaking, making signs, sitting down, standing up, bowing, and turning round, as well as those attendant upon coughing and sneezing. The noises accompanying the latter accidents and those of heavy footsteps are marked sources of alarm to a recently sighted falcon.

CHAPTER LVIII

ON THE SIGNS AND SYMPTOMS
OF BATING

The premonitory signs of bating are well known to every falconer. The falcon opens her beak, sticks out her tongue, and makes a loud, spitting noise; and she raises the plumage of her neck, throat, and other portions of her body. She gives an anxious cry, spreads her tail and wing feathers, looks her bearer in the eye, and springs backward from the fist. When reinstated she repeats these attempts to escape. Sometimes she springs over the fist away from her attendant. This she does chiefly to avoid seeing the falconer's body and face.

When the falcon is disturbed by hand movements alone, she opens her mouth in the same fashion as when alarmed by a view of a man's face; but she does not make such fierce demonstrations of alarm, nor does she bate so wildly as in the first instance.

If one touches the falcon's body unexpectedly with the hand, the bird presses her feathers closer to her body than usual and, if the interference continues, compresses them still further, raises her wings, stares at the hand touching her, and flies off. Apparently she dislikes the near movements of the hand as much as its actual contact.

When any body motion of the falconer has

been unexpected, or if he coughs or sneezes in the face of the falcon, or if he tramps about with heavy feet, the bird may not wait to exhibit the warning signs just mentioned but will bate instantly from whatever position she holds, not toward the cause of the disturbance but to flee from it.

CHAPTER LIX

HOW TO AVOID UNREST AND BATING IN FALCONS

It remains to be seen how one may anticipate bating, how the falcon may be influenced to resist the impulse, and how she may be assisted after bating in such a way that she will be less likely to repeat an act that might otherwise become habitual.

If the falconer suspects, from certain signs, that the falcon threatens to bate because of some action of his, or because she sees his face, he must decide the exact cause of the bird's fright and remedy it at once. This is a fundamental rule in all cases of bating. In particular, he should keep his face turned away from her as far as possible and speak to her in the familiar tones used while she is being fed. If this has a quieting effect on the bird, he need not give her either of the emergency rations. If not, she should be given the tiring, but not allowed to keep it after her alarm has passed.

While manning a falcon, her regular ration may be given her more frequently, but in smaller quantities than usual, alternated with the emergency ration. Frequent feeding in this way from the hand of the falconer will habituate the falcon to the sight of her keeper and make her better acquainted with and less afraid of him, even though she has her full sight and can observe everything distinctly.

The falconer must not, however, show his face to the falcon just after the latter's sight is restored, nor while her wildness lasts. If it

is necessary, for any reason, to inspect her, he should bend or avert his head as much as possible and look from the corner of his eye at her feet and not at her head. The attendant should also wear his hat occasionally, so that the falcon may grow used to it. He should also be seen without his skullcap.¹

If the falconer decides from the usual signs that his bird is startled by his hand movements and, as a result, is inclined to bate off his fist, he should desist from motions of the hand made in talking or in pointing out some object. Moreover, all movements of the hands should be slow and quiet, never quick nor abrupt. He should not touch the falcon while she continues in a wild state, nor immediately after her sight has been restored. However, should handling absolutely be required (to adjust her feathers or to rearrange her feet on the hand); it must not be attempted until the falcon has been soothed by the falconer's voice and she has been offered a portion of the emergency ration and is tasting it. Then the falcon may be gently approached (with the hand) while she is not looking. If she does notice the outstretched hand, it should neither be extended farther nor quickly withdrawn (but held in the same position), lest she be frightened or bate. At last, when the bird gazes in another direction, the falconer may advance his hand. These precautions are to be strictly observed until she becomes familiar with all these movements and permits herself to be readily handled.

Inasmuch as any movement of the falconer's body or limbs may alarm the wild bird, the attendant, when he thinks it will cause

¹ *Ut falco assuescat videre ipsum cum galero et sine pileo*, Bologna MS., fol. 55, col. 1. In the Vatican Codex, fol. 88, the miniature shows the falconer wearing his hat over his skullcap and also shows him in his cap alone. In the corresponding illustration of the manuscript of the Bibliothèque Nationale, Fr. 12400, fol. 145^v, the falconer is shown both with his hat and with bare head. At line 16, col. 2, the French translator has added to the text, *Galérons est chapiaus de fautre*.

unrest and yet is obliged to perform a certain operation, must do so only after offering the captive a portion of the emergency ration. He should sit down quietly, rise very slowly, stoop leisurely, walk about (either to the right or to the left) carefully, sneeze and cough cautiously. If either of the last-named acts seizes the falconer unexpectedly, and it cannot be suppressed and, particularly, if he is unable to offer the tiring, he must turn away from the bird, sneeze or cough as little and as deliberately as he can, stretch the fist holding the falcon as far as possible away from his face, and avert his head from the bird. In this way the falcon may be deterred from bating.

If it appears that the falcon, without any intention of bating, wishes to change her position on the falconer's fist in order to face in another direction, the falconer should not use his (free) hand to bring the bird back into position but should himself turn in the direction chosen by the falcon. He should do this in such a way that, if the bird is on the right hand, she will face toward the left (or the reverse). This is done to forestall any desire she may have to spring backward from the attendant's hand. Then the falconer should speak quietly and in familiar tones to the bird and, if need be, offer the emergency ration, to keep her quiet in the position she finally assumes.

Once the sighted falcon has been so tamed (or manned) that she has grown familiar with and accustomed to the falconer and his appliances, she will more easily be made to accept patiently other conditions that might cause her to bate indoors on the falconer's hand, for example, the sudden approach (especially from behind) of men, dogs, and other domestic animals.

The alarm signals made by the falcon when an objectionable object appears in front of her, even before the falconer who is carrying her sees it, are the following: She looks hur-

riedly about, then stares fixedly at the approaching object, keeping the feathers of her head smooth while it is still at a distance. If the startling object continues to advance, she will lower her head and ruffle the feathers of her crown as well as those on the rest of her body. The closer the obnoxious source of her apprehension draws, the more panic-stricken she will become. At last she turns her head here and there, as if seeking a refuge, and bates backward.

If the cause of the bird's panic appears from behind and she sees it before it is discovered by the falconer who is carrying her, she will often turn her head forward, backward, and sideways, trying to get a better view of the approaching annoyance. She will then hold her head feathers smooth, her eyes become prominent, she stretches her neck, makes herself appear thin by drawing her feathers flat against her body, rises on her feet, and may finally spring forward, falling below the falconer's fist.

The falconer should act at once on the appearance of these signals of the falcon's alarm. If the distressing object approaches from the front, he should speak in familiar tones to the bird, offer her the emergency ration (for the purpose of diverting her attention) and take care not to permit a nearer approach of whatever has alarmed her. Of course he should make a hasty retreat, so that the disturbing element may pass at as great a distance as possible. If the falconer finally decides that the disturbance is in the rear, he should turn his head to inspect its source, and when he has located it, he must address calming phrases to the falcon, and give her the emergency ration. Then he must endeavor to prevent the further approach of the cause of the falcon's fright. If he cannot do this, he must (with the falcon) leave the place at once. If he is carrying the falcon on his right hand, he should move in such a direction that the object of alarm passes on his left; and if

the bird is on his left fist, it should be made to pass on the right. The falcon is less alarmed by objects that she can see than by invisible ones, especially those that are behind her.

When the alarm ceases, the tiring should be taken away from the bird and put back in the falconer's pouch.

[*Addition by King Manfred:*²

If there is a contradiction in the foregoing statements that it is better that the cause of disquiet pass in front of the falcon and, on the other hand, that the worst form of bating is a backward motion (so that it would seem better that the bird's back should be turned to the cause of alarm, making her bate forward), it may be added and argued that when the object passes before the face of the falcon, if the falconer will move his arm backward as she bates and turn quickly, so as to place his body between her and the cause of her fear, she will remain quiet and will not repeat her bating. Whereas were she to bate forward because of something passing behind her, the motion of the attendant's hand, in replacing her, would seem to her to draw her back toward the object of her distress (as she still believes it to be where she first saw it, for she cannot see behind her whether it has passed or not) and she will bate again repeatedly.]

A falcon who has actually bated for any of the foregoing reasons may be rescued from her predicament in the following manner: If she continues to bate backward, away from the falconer's face, even after he has tried to soothe her with the usual sounds and the use of the tiring, the falconer must turn his head away and quickly draw in his hand and turn, so that the falcon can regain her former stance. She must on no account be forcibly replaced on the fist, because that will hurt her and make her wilder.

² Vatican Codex, fol. 89, col. 2, l. 31, to fol. 89^v, col. 2, l. 4.

When she is once more on the fist, the falconer, without looking at her, may give her the tiring with his free hand; but he must do it gently without any sudden motion that might frighten her, because this latter error would be fraught with even greater danger than the initial accident.

Bating that results from false movements of the hands, whether they touch the falcon or not, is to be rectified without delay in the same manner, the falcon being drawn gently back upon the hand. The method of rescuing a falcon that bates because of a sudden movement of the falconer's whole body, or because of a fit of sneezing or coughing (that always makes a falcon jump in the direction in which she is facing), must depend upon her stance on the fist. If she has assumed an incorrect position, she will not bate over the front of the hand, and it will be more difficult to recover her. If, however, she is standing correctly, the task will be accomplished easily and with little distress to the falcon. The falconer need not turn around but can simply lift her back with his hand.

After a falcon has bated backward, because of a man or dog approaching from the front, or forward, or off the end of the hand (because of danger from the rear), she must be replaced on the fist in the appropriate fashion.

The newly sighted falcon should be manned and made familiar with her surroundings little by little for several successive days and, at first, kept in a darkened mews until she remains quiet and is no longer alarmed by her entourage. She may then be moved to somewhat lighter quarters, and from there to still brighter ones, so that she grows gradually used to seeing a great variety of objects. As the light is increased and the number of possible causes of alarm is augmented, the tiring should be given more frequently. The whole process that has been followed in the taming of the seeled or the

half-seed falcon must be carried out step by step, thoroughly and gradually, also with the sighted bird, so that there may be no need (through too rapid or insufficient training) to return her to a darkened room or to re-seed her. Falcons whom it is necessary to handle repeatedly in this last-mentioned manner become, as a rule, vicious and utterly useless.

All falcons, wild and tame, tire of being carried too long on the fist, and look for a change to some other roost. If this desire is not granted they become restless and bate. This is particularly the case with those that have been badly carried or are too often taken for long tramps outdoors. They look about for a resting place other than the falconer's fist, and make their wants plainly known in the following ways: Toward evening the falcon becomes more restless, especially as this is her normal hour for seeking a tree (or some other high or safe place) to rest upon. Indoors she looks about for a desirable perch, and springs in its direction as she would outdoors and, if she is not allowed to go to roost at once, she repeats the performance and may injure herself in these attempts. When the falconer notes her efforts, he should change the bird to the desired perch. If this is not feasible, she must be placated with the tiring so that she may forget her longing for a change and be content to remain on the fist. Then the falconer should leave the locality where the bird saw the new and preferred resting place.

CHAPTER LX

ON THE POSITION OF SIGHTED FALCONS ON THE PERCH¹

[*Addition by King Manfred:*

As it has not been stated in this work exactly how one should place unseeded falcons on their perches, how they should be removed from them, or what the dangers are of alarming and injuring the birds during these acts,

and as it was noted in the margin (at this point) that the present chapter should be added, we have considered it desirable to insert here as much as we feel is necessary for the better elucidation of this treatise on falconry.

When placing a falcon on a high perch, choose one erected in a chamber that is neither too dark nor too brightly illuminated, i.e., with just enough light to enable the falconer to attend to his duties. Care should be taken that there be no aperture nor window allowing light to fall at right angles to the perch, because the falcon would then be attracted by it, and if she were to bate would do so in the direction of the bright light. When the lighted opening is lengthwise of the perch, bating is not so dangerous for the falcon, because her wings (when she bates lengthwise of the perch) are then on either side of the pole or platform, and more likely to escape injury. It is impossible for her to bate in any direction except upward if she wishes to spring along the perch, as the rack itself interferes with any other course.

In springing forward (across the perch) the falcon would strike both wings against it and be seriously injured. If one wing extends beyond the end of the rack, it may not be affected by the spring; but, as the falcon is tied short to the high rack and there is no play to her jesses, she will be sure to injure that wing (in climbing back) against the end of the perch. As the high perch is a foot wide, there is also danger of the falcon striking her breast against the edge in a forward bate. This is by far the most dangerous of all possible forms of bating.

In approaching the high perch (carrying the falcon) the falconer should offer the bird the savory ration, speak his customary soothing phrases, and keep his body between the

¹ This whole chapter is, presumably, the work of King Manfred. It is not found in any of the six-book manuscripts. In the Vatican Codex it runs from fol. 90^r, col. 2, l. 13, to the end of fol. 92^v.

perch and the falcon on his hand, so that she will not see it and spring toward it before it is reached. To accomplish this the falconer must move backward; and, when he is near the rack and the falcon's attention is fixed upon the tiring, he must take the long end of the leash in his free hand and place it quietly over the perch, regain his hold of it below, and wind it again about the stand. Then, gently taking the tiring from the falcon, he must cautiously gather both ends of the leash in the hand carrying the falcon and draw that hand away from under her; by this motion she finds herself standing on the perch. With his free hands the falconer now ties the leash in the manner previously described. When all this has been performed, the falconer, with head bent away from the bird, and taking every other possible precaution, should leave without any disturbance, so that she will remain quietly and at ease on her perch. But he should not go too far away lest, if the bird becomes restless, she need his immediate help.

The attendant should also be on the lookout for indications of bating from hunger (when she attempts to fly off in search of food as in her days of freedom), or because of light from an opening somewhere in the room, or because of a window through which the bird is trying to fly; or her agitation may result from fright caused by cats² or dogs, or she may see a mouse or other small animal that she attempts to catch, or she may bate because she has been confined for some time and simply has a desire to fly around (for exercise or pleasure).

When she is hungry and, as a consequence, threatens to bate, she walks up and down on the perch, looking about her. She spreads her wings in a pretty manner and makes short though not vigorous jumps—all of which is not dangerous. However, when she is attracted by a window and steadfastly fixes her

gaze on it, walks toward it from every side of her perch, opening and closing her wings as if she intended to fly through the window, and, finally, springs toward it, that is a much more serious affair.

When the falcon on the perch sees anything that frightens her, she behaves as she does when on the fist; she turns her head from the object of alarm and tries to run or fly from it. When she spies possible prey she fixes her gaze on it and tries to attack it without warning and with a sudden spreading of her wings.

Apart from these four forms of bating from her perch, there are other kinds of unrest not followed by bating that are not infrequently due to starvation. She may on these occasions twist the knots of her jesses, or bite them or her bells, either to regain her freedom or from dislike of her fetters and her bells—all this because she is hungry.

When the falcon bates on account of light from a window it should be closed and, while the falconer is performing this task, she may be further quieted by calling gently to her, so that she may forget the source of her fright.

When the falconer decides that some article in the mews is the cause of the falcon's alarm, he should stand in front of the bird so that she can no longer see it, speak to her in a soothing voice, and have the offending object removed. The same rule should be followed when live animals (e.g., mice) appear in the falcon chamber.

If the sources of bating in the mews cannot be traced, the falcon probably has a desire for flight into the open air, which she has not enjoyed for a long time; so the falconer should try to pacify her by taking her on his fist.

If a falcon is quiet and shows no signs of bating she may be left on the perch until the regular hour for taking her on the hand. As she may endanger her body and feathers by

² *murilegos*, mousers, cats.

attempts to fly off her perch—conditions that interfere also with her taming—the falconer must not leave her alone for long periods and must, if need be, resort to the usual soothing remedies to prevent a relapse into her former wild state.

And if he sees that she is restless, the falconer, to conciliate her, should approach her perch and softly repeat his lullaby. When this has been effective he may retire, leaving the bird alone, but not for too long, as too much rest and waiting for the return of the attendant may lead to bad or wild habits. If the usual ingratiating sounds are not effective, he should approach the perch and, standing near the falcon, again gently repeat his soothing phrases and, if successful in quieting her, he should leave her to rest. If these efforts are unavailing he should take the captive on his fist in the following manner: Holding the emergency ration in the hand that is to receive the falcon, and keeping his direct gaze turned from her, the attendant must place the hand with the ration before her on the perch so that the bird may see it clearly. Holding this hand steady, he should repeat continually his soothing words and allow the falcon to grasp the meat with beak and talons. The food should be held so fast that she cannot easily remove it. The attendant's fist and the rest of his body should be motionless, so that the falcon will have the courage to place her foot on the hand. As she grasps the tiring with her foot, the falconer should gently unknot the leash beneath the perch; but before releasing the end of it, he should attempt to gather the falcon's jesses into the hand upon which she is standing. If this is not possible, then, holding the short end^a of the leash he should unwind the longer end from the perch. Now he can grasp the two ends of the leash and slide his free hand upward, toward the knot that holds the jesses. Taking these in his

hand he will now slip them into the other (that holding the falcon) and quietly lift the hand with the falcon from the perch. He should turn his fist so that the breast of the falcon is toward the perch. This precaution is taken so that if she bates in the direction of the perch it will be forward and not backward.

The falconer should now turn so that his body is between the bird and the rack, and walk so far away from it that the falcon will not wish to bate toward it. The tiring may now safely be taken from her. The falconer should also be careful to pass gradually (as before advised) with his bird in training from the darkened mews to a more brightly illuminated chamber, so that the falcon may gain confidence and become used to well-lighted quarters.]

CHAPTER LXI

FURTHER REMARKS ON THE TAMING OF SIGHTED FALCONS HELD ON THE FIST

When the time arrives for the falcon to be taken out for an airing, where she will see distinctly many dreaded objects that she will remember having seen in her wild state and that will disquiet her, it will be wise for several days before making this trial to reduce her diet so that her hunger will be left somewhat unsatisfied. In this way she will take the tiring more avidly when it is offered her outside. In deciding the amount of the ration to be thus allowed, the trainer must consider the degree of wildness, emaciation, and eagerness for food exhibited by the bird. If hunger is so great as to overcome the handicap of the falcon's wild condition (i.e., when some occurrence that usually alarms her does not cause her to neglect the tiring), her diet should not be reduced further. However, if her wildness overcomes her hunger under similar cir-

^a The end with the button or knot.

eunde: modū. Namq; iſtū
falconiū dicitur ea q̄ dicitur
laudatibiles erunt. Quid appo
tuntur hinc q̄nto plus appo
tuntur tanto laudatibiles
erunt pot' ules: De factis:

Ita ſcōm formā mētor
ſic ſe habent approxi
mant ei groſſaloni
in magnitudine corporis plus q̄
ceren modi falconiū ſunt tū m
nores groſſaloni. Itaque ei
pud mag' rotundi. roſtri bre
uius. corp' ſituali. longius in
apertione ſua. Ita longiores.
caudam. & longiores. Petus mi
nus circuloſum. & min' cenſum
reſpectu ſui corporis qm groſſal
ni. Digtos pedum hinc breuiorē

Per totam formā. & p̄oeno
nem memtor in factis. & p̄ pul
cū plumagū eorū n̄ p̄t' h̄
lexi certū ſignū & laudatibiles
vō. q̄dmodum habet in gro
ſſaloni: & ceren mōis falconi

Ita dicitur dicitur dicitur
hor est. iureſt' ſine mi
tan iueniunt' de r̄t' ſo
plumagio. Nam alii ſunt v̄nū
reſcentes. to nigredines. alii ſūt
ſubtiler. alii ſunt flauū. Q̄ om̄
poſt maturore p̄tūm diſtina
tantur in plumagio a ſe n̄ mu
tatis. De gemtibus. p̄grius
Eniles p̄grius ſunt
m̄ m̄ falconis. &
cho. & c̄nens forma

& melior ē m̄ eis qm habent q̄
& meliorē formā groſſaloni
ſolū rotundū groſſum. & amū
ſeu adunū. ap̄tes amplis. & q̄
mū caput planū & equū. nō ele
natum nec tumoſum. Oculos
r̄cauos. Sup̄cilia ſeors p̄minen
tia. Poſterius caput ſp̄tūm
cauum curuū. & p̄ caput ſub
tile. & ſus ſp̄tūm groſſum. &
Partem colli n̄t ſp̄tūm eleva
tam. Foſſam n̄t p̄ctus & colla
l̄aber amplam. & p̄fundam. & q̄

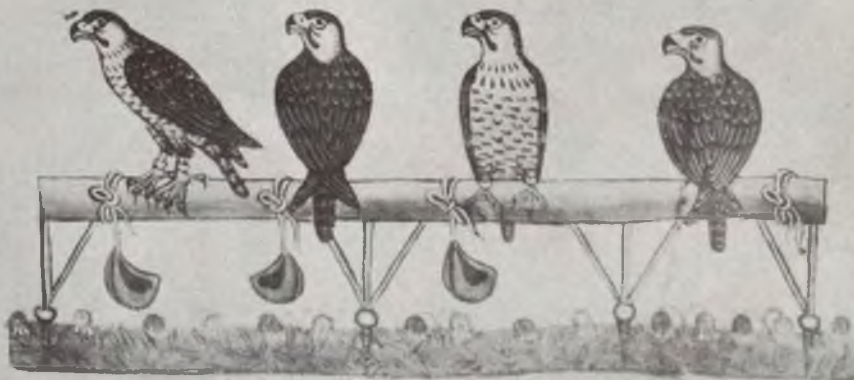

PLATE 83.—Examples of low perches (from the Vatican Codex, folio 54)

un i qua potare dicit falconē
 elongat sine sua a sine fal
 cone uersus aliam manu po
 ner manu ai qua tenet tara
 toū ai falconem sup pncam
 ostentando sibi nratonū sic apr
 re q falco ipm plene uideat
 distentat - manu ante falconē
 tenear ualde firmā pferendo
 sibi ingit affuetum somi quo
 usq falco nratonū capar. aut
 ai lecto aut ai pedibz qd si
 ai lecto cepit tenear nratonū
 ita firmū qd sibi s manu non
 possit subire et ita enā fir
 met manu et ut unobā ma
 ueat q falco se affuetur pe
 des ponere sup manu et cum
 recepit nratonū ai pedibus
 apperimet alā manu suam
 et - dissoluat nodum factū
 sub pncā - ante qm longe ca
 pta detrahūt. accipiet ai ma
 nu tenente falconem iactos
 si poterit. Et si forte n poterit

recto: sicut manu ita q pncā
 remanere. nre pncā falco
 nis sic q si falco se uelit au
 berare ad nreundū in pncam
 se ante duertat. et non ut
 et falconis nratonū poterit
 ueher psonam suam nre
 pncam - falconem et talem
 mediar due recedat qusq in
 nū dicit a pncā q falco oc
 catione nre pncā nō habe
 at marenam se dnterandi
 ad eam. Et deinde potit nre
 subtrahere nratonū a pedibz
 falconis. Cautus sit tunc fal
 conatus q i mutando falconē
 delectat s domo pncā elata
 ad elatam - s elata ad elatā
 rem formā et regulam nratonū
 s mutato falconē elatā
 tenet et tenear eae gradatū
 hoc faciendo q falco se affe
 curet et affuetat manere
 in domo elata. De manu fa
 lone falconū delectatū sicut



PLATE 84.—The high perch (from the Vatican Codex, folio 92^v); illustrating also, the proper
 method of lifting a falcon from her resting place

le faucon dou liage sus la
main quil wurt li quelz

monter dou fauconier sus
le cheval et mit mors ce



estera

faucniers monte sus le
cheval cest li milloes car
par ce li faucos cestee

con se debator sus le col
du cheval il perdit auc
un q li cheuals dou mou



PLATE 85.—Falconers demonstrating the incorrect method of holding the falcon when mounting a horse (Bibliothèque Nationale MS. Fr. 12400, folios 162^v and 163)

o timor autem temporibus dicitur
 amplius in capitulo dicitur
 falcones dicitur regione in regione
 de equite qualis esse debeat et
 que secum foras portare de
 qualibus et qualis debeat et
 de his et de quibus morum

mittitur tunc mutet falcones ad
 dexteram manum et fumens ipse
 de sinistra quomodo de se ad
 manum ad dexteram postea det
 rinationem falconis tunc ipse
 uocabitur confuens ad dexteram
 forte et inde postea ipse

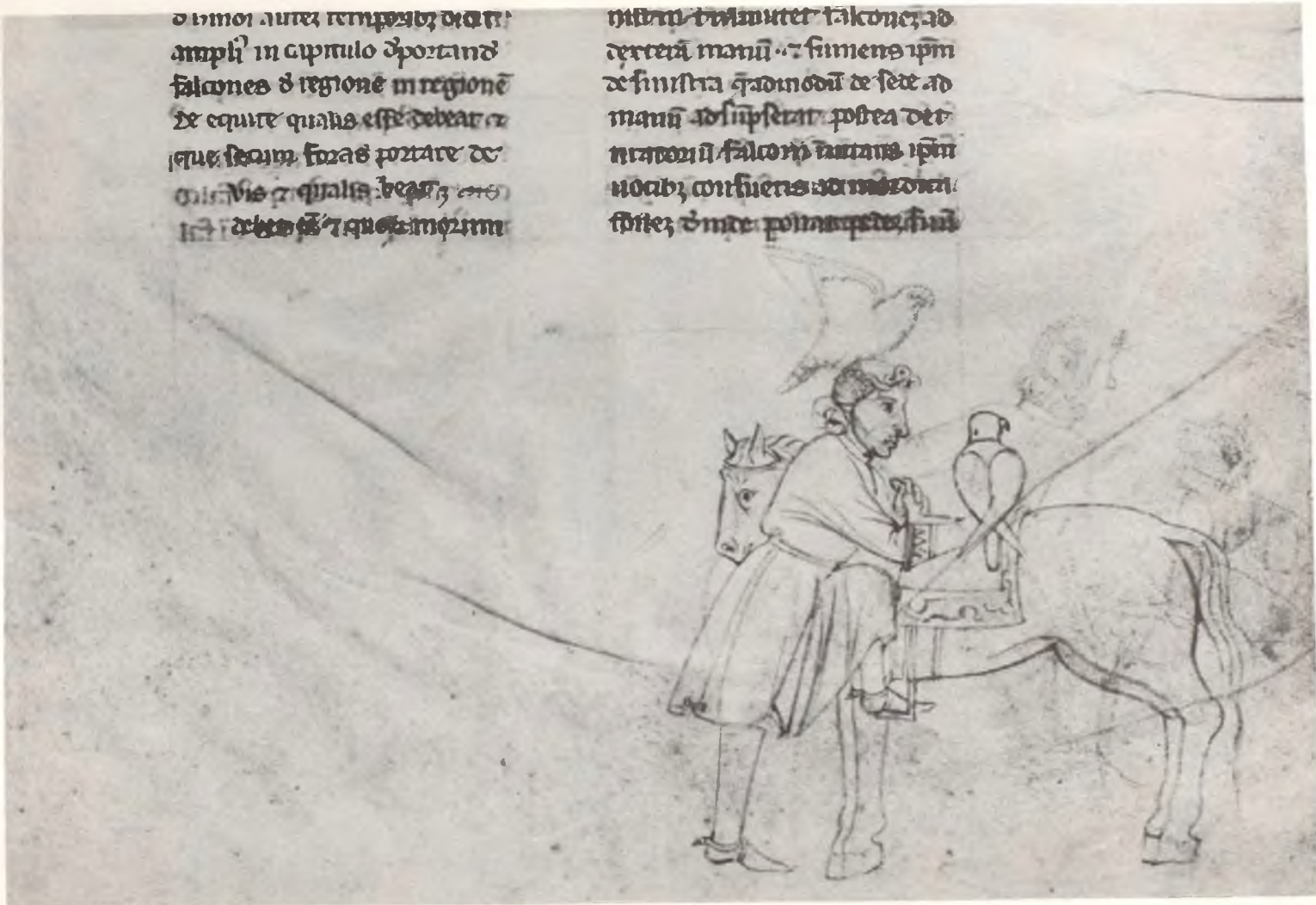

PLATE 86.—A falconer in the act of mounting, illustrating the correct method of holding the falcon when performing this feat; an example of the unfinished miniatures of the Vatican Codex (folio 98)

cumstances, she is to be still more strictly rationed. Account must always be taken of her physical condition and her feral state.

CHAPTER LXII

OF THE TAMING OF FALCONS ON FOOT AND ON HORSEBACK

After the wild falcon has been tamed in the mews and has been fed rather small amounts of food, she may be taken outside by the falconer, first on foot and then on horseback, and so grow accustomed to the objects she will encounter out of doors. On suitable days (to be discussed in the following chapters) the falconer will remove her from her perch, leave the mews early, and go about outside for short periods while it is still dark, so that with the coming of daylight the bird will gradually become familiar with the sight of surrounding objects. Let this be done early, as in a fog, the first time, then more clearly, and, finally, with great distinctness. It is to accomplish this that we have advised the falconer to take the half-seed bird out for several days (on foot and horseback), and at last the fully sighted falcon on foot, always taking the precautions explained in the following chapters.

CHAPTER LXIII

HOW TO CARRY A FALCON OUT OF AND INTO THE MEWS THROUGH A DOORWAY

It is more satisfactory to give the falcon an airing in foggy or rainy weather (a fine, misty downfall is best), because then the bird does not see things distinctly and her feathers get wet—conditions that discourage her bating and make her keep quiet. Such weather makes her inactive, as is the case with other animals.

To leave the mews the falconer must pass through a doorway, and care must be taken

in doing so lest the falcon bate and be injured. Hence, whenever the attendant (with his falcon) is going to pass in or out, he should speak softly to her and give her the tiring, then approach the door sideways, with (first) that part of his body farthest from the falcon. The hand upon which she stands should be extended away from him and from the doorway. He must then put out his head and look around. If he sees anything that might alarm the bird he should have it moved to a more distant position or, if possible, taken away entirely. The falconer may then cross the threshold. When outside he ought to take away the tiring. This plan should be followed regularly until the wild state of the falcon has been overcome.

CHAPTER LXIV

WHERE THE FALCON SHOULD BE TAKEN FOR HER FIRST AIRING

When the falcon is carried outdoors for the first time she should be transported to some place where she will be least likely to see unfamiliar objects. A good locality is in front of an unfrequented wall or other barrier. There the falconer takes his stand with the falcon's back toward the wall and so near it that nothing likely to excite the bird can pass behind them.

Should anything likely to frighten the bird appear elsewhere, the falconer should not leave his position but should try to prevent an approach of the alarming object, or better, to get rid of it altogether. If unsuccessful in this he should quiet the falcon, using his soothing tones and offering her the emergency ration. Such precautions will be all the more necessary if there is no protecting wall behind the falcon and her attendant.

The bird must afterward be carried about and permitted to grow acquainted with her surroundings.

If a strong breeze rises (an event that will be discussed also in subsequent chapters), the falconer should turn in such a fashion that his body protects the bird while she faces the wind. If a wind is allowed to blow on her back, it makes her very unruly and she is likely to bate.

CHAPTER LXV

WHEN THE FALCONER SHOULD CARRY THE FALCON BACK TO THE MEWS

After the falcon has been carried about outdoors on the fist for a considerable period, as described, and the sunlight is becoming stronger and men and animals commence to go about in large numbers, she should be returned to her mews.

CHAPTER LXVI

HOW A FALCON REPLACED IN THE MEWS BECOMES RESTLESS AND BATES FREQUENTLY

When a falcon is carried out of doors, she will see clearly in the open air many things that she did not view in the mews and that will remind her of her wild life in the open. This will cause her to bate more frequently and vehemently than she has hitherto been doing indoors. Taken inside, she at once recalls her out-of-doors experiences, longs for a return to her former freedom in the air, gazes fixedly at the window, and springs toward it even more often than she did before her airing. She will bate more persistently, in the same way as before; but it must be remembered that this unrest is due more to her longing for an outdoor life than to the spectacle of the human face and room furniture, to which she has already grown somewhat accustomed.

CHAPTER LXVII

ON SOME REMEDIES FOR RESTLESS- NESS AND BATING

It is necessary, if the falcon is to be properly tamed, that she desist from frequent and vigorous bating, and we must put an end to it whenever it occurs. The emergency ration should not be utilized too often for that purpose, as it will make the falcon fat and she will lose her desire for it. Yet if she is not given the tiring when needed, her continual restlessness will damage her plumage and limbs and she will lose her energy. When, therefore, the signs of disquiet appear, try the soothing lullaby and let her have the cold leg of an unplucked bird, or a bony limb with the sinews (but no meat) on it.

CHAPTER LXVIII

ON SPRINKLING THE FALCON WITH WATER

If the falcon is not quieted by giving her either of the two last-mentioned forms of the emergency ration (because of her disappointment in them), she should be sprinkled with cold water and her plumage thoroughly dampened. To do this properly, the falconer should first wash out his own mouth three or four times with cold water, to cleanse it of mucus that might otherwise adhere to the bird's feathers and make them sticky, also to cool it lest the water become too warm for the proposed purpose. Then, filling his mouth with cold water, he should spray the falcon all over with successive mouthfuls, including in this ablution the bird's back, chest, sides, and under-wing parts, until all these areas are thoroughly wet. As long as the bird tries to fly off the hand or perch, this may be continued, but as soon as she settles down and is quiet it should not be repeated. This spraying, so long as she is untamed, should be done in a dark room.

The value of spraying is manifold; the falcon loses her desire to bate because her wet feathers make her lazy; moreover, she loses confidence in them as a means of support, is somewhat languid and feels that she must keep quiet and wait until her plumage dries. To facilitate evaporation she lifts all her feathers and spreads her wings out wide, shaking herself frequently to get rid of adherent drops of water. One may resort to sprinkling the falcon also as a refreshment, especially during the heat of summer, when it may be done every day more than once, for then the feathers dry quickly. Finally, sprinkling may, on account of its quieting effects, take the place and save the consumption of food rations.

We have now shown that during this period of taming there are occasions when the falcon should be sprinkled and others when she should be given either the succulent tiring or the sinewy leg of a chicken. She should be allowed only a little of the former, lest her daily ration be exceeded. Sprinkling may be useful in other emergencies, as will be explained later.

We wish to emphasize that once the sighted bird has been taken into the open air and brought indoors again she is to be watched more carefully than ever, to prevent her bating, or at least to assist her if she does bate, because all her previous restless tricks will probably be indulged in more frequently and with greater energy.

Another observation may here be added regarding the falcon who, when outdoors, bates behind the fist. She should, of course, be replaced; but one must first note whether there is a wind blowing or not. If there is no wind, the bird should be returned promptly by the shortest possible maneuver to her place on the fist. If, however, there is a strong breeze the falconer must first turn his back to it while the falcon, by strategy, is brought in front of the falconer's breast and quickly

replaced on the fist without permitting the wind to blow against her back. She can also be restored to the fist more easily when the gale does not blow from behind her, because all birds prefer to face the wind both when alighting on the perch and when resting there.

CHAPTER LXIX

ON THE FALCON'S BATH

Not only is the bath one of the best remedies for the unrest and bating of the falcon but it also assists in taming her and in familiarizing her with human beings.

Falcons and other birds of prey have a drier and warmer nature than harmless birds, and in their wild state are accustomed to bathe themselves lest they become ill—a subject that will be further discussed in the book devoted to avian diseases.¹ For these reasons we must make frequent use of the bath, not only during the period of taming our falcons but as long as we own them.

The bathing vessel itself should be of wood or earthenware, with a diameter of at least two feet and a depth of water that reaches to the ovaries of the bird, the latter a measurement regulated by the length of her legs. The water should be cold, clear, fresh, and without any dirty deposit, while the container should be free from rust² that, spreading through the water, might damage the falcon's feathers. The bath must be securely located in a mews, garden, or field, to which no dogs, pigs, or other animals that would frighten the falcon have access.

The best season for bathing is the sum-

¹ This treatise, as we have said, was lost or was never written.

² *Vas nullam habeat vetuositatem*, Bologna MS., fol. 58^r, col. 1; the Vatican Codex, fol. 96, col. 1, says *ventositatem*, and the Mazarine MS., p. 235, *unctuositatem*. The Old French translation (Bibliothèque Nationale), fol. 158, col. 2, reads: *Li vaissiaus nait nulle de rostreï.*

mer, although the bath should be given also in winter and at other seasons. In summer falcons ought to bathe before the sun's heat becomes intense. In winter and at other times of the year, although the birds may bathe after the sun is well up, too great delay in giving them a bath out of doors must be avoided because of the presence at midday of eagles, vultures, kites, and other large raptors that soar in the sky. At that hour it is wise to let the falcons bathe indoors.

The bath should be given at all seasons after a meal when food should be offered more sparingly than on other days. If, however, the falcon is losing flesh and continues to grow thinner, the attendant may feed her additional food after her bath and when the previous meal has had time to digest. This food may be given her about the second hour³ and in such an amount that, taken with the morning meal, it will make a full daily ration.

The falcon should not bathe every day, but the intervals between baths must not be too great. The bath may be offered to any falcon. It is especially good for the wild bird that has been recently unseeled, as well as for one that is fully tamed. Even those ciliated subjects whose sutures are only partly relaxed may be bathed, and we have seen the bath offered to completely seeled falcons. It is even possible, if one wishes, to bathe one's falcon on the very day of her seeling.

If the falcon is still wild, a stool or stone block is placed near the bath and the falcon tethered to it. If no stool is available but a stone is used, a wedge or stake should be driven into the ground beside the tub and the leash tied to it. Then the falcon may be placed on the stand still wearing her hood, if she has been tamed with that covering. The leash should now be tied and left long enough to permit her to enter the bath but not so long that she can cross the tub. If the falcon is

wearing the hood, it should be removed and the attendant should go far enough away, while she is bathing, to allay any fear she may have of him yet not so far off as to lose sight of her altogether. If she has been recently sighted and is not wearing a hood, she is placed near the bath to bathe if she wishes. While she is still wild the falconer must not stay near the tub.

When the bird has taken her bath the attendant should return to her in a roundabout way and not go directly toward her.

[*Addition by King Manfred:*⁴ keeping the arm on which she is to be carried toward the falcon and taking care to look always away from the falcon], the falconer should approach the bird gradually, offering her meat (the tiring) borne in the hand by which she is carried. She should then be taken from the block in the proper fashion and carried out into the sunlight, that she may dry and anoint her plumage; if the sun shines too strongly she should be put in the shade. Speaking about the falcon's bath, we have said that the falcon will "anoint" herself after it. To explain: Upon this and other occasions she presses oil from a rod-like elevation (*virga*) directly over her tail, where two glands, provided with ducts, are situated. With this oil she thoroughly oils all the flight and contour feathers of both sides of her body as well as her feet. This she does every time she bathes and frequently in between.

If, however, the falconer returns to take up the falcon after her bath, offers her meat, and she refuses it, he should wait until her feathers are dry, then come as close to her as possible without frightening her and squat down sideways with his carrying arm toward her. He may now renew his offer of the meat and take her on his hand. If she does not begin to anoint herself, he should carry her into the shade and hold her until she does. Should

³ *circa secundo*, Bologna MS., fol. 58^v, col. 1; i.e., eight o'clock. The Vatican manuscript says *circa sero*.

⁴ This short (Manfred) addition is taken from the Vatican MS., fol. 96^v, col. 1.

she hold out her wings and spread her tail and all her feathers, it is a sign that she is enjoying the sun.

When the seeled, or half-seeled, falcon is ready for a bath, she should be brought on the attendant's fist close to the tub and the water splashed with a wooden rod. As soon as the bird hears the sound of the water and evinces a desire to bathe, she will stoop over and point her beak toward the pool. Then the falconer must move the hand that carries her until her feet come in contact with the water. He should again splash the water with his wand, and the bird, hearing it, will show her desire to enter the bath by changing the position of her feet on his fist. If she then steps into the bath, the falconer should remove his hand and permit the bird to bathe. Nevertheless she should still be encouraged to take a complete bath by splashing the water with the wand.

When the falcon plainly shows a desire to come out of her bathtub by moving about as if to seek an exit, the falconer should take the long leash in his free hand and draw on it, put the other hand into the bath, and gather up the jesses close to her feet, so that she can regain once more her place on his fist. She is now placed in the sun until she finishes drying and anointing herself.

If the bird does not care to bathe and shows her antipathy by turning away and becoming unruly, the attendant should abandon further efforts to induce her to enter the water. If, however, the falcon is a tame one, she may be tied or held by the long leash and the water splashed about with a rod, and other means may be adopted to encourage her to bathe. Afterward she is treated in the same manner as other falcons.

The purpose of the bath is, of course, to preserve the falcon's health, to tame her, and to cool her off when overheated. It will be found of great value in taming her. Holding her on the fist until her feathers have dried

and she has anointed herself is a measure that will assist, in no small degree, in her domestication.

To sum up: When the falcon is first carried outdoors on foot, it will be found that bathing, spraying, and the frequent use of the tiring (in both forms) are effective measures in quieting her and preventing her from bathing. Moreover, out of doors when the falconer turns quickly to bring the bating falcon back on the hand, or even when he makes no turn of the body, he should be alert and notice which way the wind is blowing so that it does not strike the falcon's back. Wind from the front against her breast is of assistance in returning her to her place on the hand. Bating from the hand of the pedestrian falconer should be treated in the manner and with the same care outside as indoors. The special reasons for bating in the open will be treated in the next chapter on the taming of the falcon on horseback. All of the foregoing instructions should be carefully observed until the falconer is sure that his hunting bird is thoroughly tamed and is glad to be carried about in the open air.

CHAPTER LXX

ON THE TAMING OF FALCONS ON HORSEBACK, AND OF THE MOST SUITABLE HOURS FOR THIS TRAINING

In training the falcon on horseback all of the foregoing instructions are useful. In addition, a number of provisions must be made and precautions taken. One must consider the state of the weather, the disposition of the horse, the equipment of the falconer, the proper method of holding the falcon when mounting, and what localities may be visited. One must also discover what may be special causes for any bating and how the falcon is to be assisted under these circumstances. We should note, too, at what hour she should be

brought in and how to dismount with a falcon on the hand.

Not every kind of weather is suitable for every falcon. Some birds adapt themselves better than others to certain weather conditions. In general, a quiet, windless season is preferred by hunting falcons. In summer a cloudy day is best, as it is then cooler and the rays of the sun are not so penetrating; indeed, for wild birds overcast weather is desirable. Fine rain without wind is favorable to untamed captives, whether they are eyases or branchers; because the falcon is sheltered by the person of her carrier, who can always keep his bird directly in front of him, it matters not on which hand she is carried.

All frontal winds are harmful and the one that blows straight in the face of the falconer is the worst, for there is no protection afforded the bird. Side blasts are more harmful when their direction is frontal, less hurtful when they are partly from behind. In the chapter on carrying the falcon from one region to another the weather will be discussed further.

CHAPTER LXXI

THE FALCONER ON HORSEBACK AND HIS EQUIPMENT

In speaking of the pursuit of the crane by the gerfalcon¹ the desirable qualities and disposition of the horse will be fully discussed.

The falconer must always carry with him various emergency rations that the falcon likes and easily digests. It is not possible to say exactly what snacks the falconer should keep in his pouch for his falcons. Some birds prefer one kind of food, others a different sort. He must decide this question from previous experience.

When the falconer takes a bird out for an excursion on horseback, he should rise before

¹ Book IV, chapter vii, p. 280.

daybreak and place the bird on his fist. If he decides to mount his horse from the left and is bearing the falcon on his left hand, he should transfer her to the right, employing the method used in taking her from the perch. At this juncture he should give the bird some emergency ration to eat, talking to her meanwhile in the usual manner. Placing his foot in the stirrup, the falconer should grasp the pommel of the saddle with his left hand and, with his right (that bearing the falcon) take hold of the cantle, support himself in the stirrup, raise his body, lift his right hand (carrying the falcon) from the cantle, throw his right leg over the horse's back, and settle himself in the saddle. Following these directions the falcon is in little danger of injury and will very likely remain quiet. In mounting the horse on the right side the rules are reversed.² By changing the falcon to the appropriate hand, mounting is accomplished with little danger; but care should be taken that the horse's head faces the wind. If the falconer mounts his horse with the wind blowing directly against the latter's rear and (in order to bring the falcon's breast into the wind) he places her on the hand with which he grasps the pommel or (like many) the horse's neck or mane, he runs the risk, in swinging himself into the saddle, of crushing the falcon or of frightening her by a movement of the horse's neck. Moreover, when the falcon is carried on the fist that grasps the pommel, the motions of the horse's mane, or a close view of the falconer's face (brought near hers in mounting) may alarm the bird and make her jump to the horse's neck, terrifying that animal and causing him to run away and so expose both falcon and falconer to imminent danger. It is therefore wise to follow our method; also to give the emergency ration to wild falcons as yet unaccustomed to horseback.

² In the original text the full directions for mounting from the right are given.

Once in the saddle with the falcon on his fist, the falconer should ride along slowly and in localities where the bird, unaccustomed to the motions of the horse and other new sensations, will have less cause than usual to take fright.

The first excursions of horseman and falcon should be made to places where there are no ravines, no forests, and but little water, where they are not likely to meet vehicles, many men, or other animals, and where there are no bushes or brambles, because the falcon will be alarmed by all these objects and their accompanying noises.

CHAPTER LXXII

ON THE TRANSPORT AND SURROUNDINGS OF UNTAMED FALCONS WHEN ON A JOURNEY

We have described the taming of a falcon (without the hood) indoors and in the open air, when there is no necessity for carrying her from one locality to another. Now let us see what care must be given the untamed falcon when transporting her from place to place.

The newly captured and seeled falcon must learn, before she is taken on a journey, to feed from the falconer's hand and to recognize his voice. While she is doing this she should be handled and carried here and there in the neighborhood of the mews more frequently than if she had no journey ahead of her. In this manner she will gradually learn not to be frightened by adventures on the way.

As is well known, all falcons (at least those caught in their wild state) are taken as a rule in summer, autumn, and spring, rarely (and then only through accidents) in winter. Those caught in summer should be transported at night, especially in hot countries, because, even though their eyes are blinded, they suffer from the glare and heat of the sun. Moreover, the captured falcon would

in the daytime hear the call notes of the birds she is accustomed to prey on and she would become still more unruly; while at night she will not be disturbed by these and other sounds that alarm her. At that time, also, she is more sluggish and, like other birds, inclined to rest. She is also able (to some extent) to benefit from the stillness and coolness of the night.

If this plan cannot be followed, the falconer should rise shortly before daybreak¹ to set out on his journey, carry the bird until it gets hot, and then allow her to rest until the temperature has moderated. If he is obliged to travel during the heat of the day, the falcon should be sprinkled repeatedly with cold water from the attendant's mouth (in the manner previously described). Also several times during the day she should be given meat soaked in cold water.² The total daily allowance of food should not be given the bird at one time, as that would damage her digestion, because of the shaking incidental to transportation. Finally, it is a good plan to moisten the bird's food with cold water, because all birds of prey, especially falcons, being hot-blooded and of a dry nature, are rendered uneasy by the excessive heat of the day and if the meat were not placed in cold water it would harden and cause disease. Birds fed upon moist, cold meat will better resist both their own innate heat and the heat and dryness acquired through restlessness.

For the same reasons, falcons caught in the autumn (though the weather is less hot) are better transported by night than by day. If it is found needful to carry them while the sun is up, the same precautions should be taken that are suggested for travel in summer.

In winter conditions are reversed, so that it is better to journey with the birds during the daytime, when they are not exposed to the extreme cold of night. Nor is restlessness

¹ *summo diluculo.*

² Not to be confused with the washed meat usually given as a remedy or purgative.

caused by extreme heat to be feared as in summer.

If there is likely to be more harm done the falcon because of her unrest, or from some other danger encountered during the day, than from the coldness of the wintry night, the falconer had better choose the latter for his journey. If he does, a misty rather than a clear night is preferable, because in such localities the latter is particularly cold.

When the falcon is carried during the day in winter, one should choose either a bright day without wind or clouds or a cloudy one without wind or a too low temperature, because although, generally speaking, a clear day is objectionable, yet it insures warmth, that for the falcon is desirable in winter time. The emergency ration may be given more frequently during the winter, partly because it is not desirable to sprinkle one's falcons. Also, the falconer is not required to rise before dawn but may await the sunrise. Whenever the falcon is carried about on the fist in cold localities, by either day or night, the falconer's glove should be covered with fur that keeps warm the bird's feet as well as her whole body, and so mitigates her discomforts.

Falcons caught in the spring and carried about from place to place should be treated in about the same fashion as those taken in the autumn.

Let us repeat: Winter, by either day or night, is the least desirable season for traveling, because the nights are cold and the falcon is restless in the daytime and cannot be helped by spraying. Also, storms are more frequently encountered in winter. The summer is less desirable for the transport of captive birds than spring or autumn, for the days are too hot and, in northern countries, if a long journey is ahead of the bird and her carrier the nights are too short for the purpose. Finally, spring is better than the autumn, for at that time fine days are more common.

The most favorable meteorologic conditions for a journey in the daytime may be summed up as follows: Misty weather or heavy clouds without wind are excellent; the thicker the clouds the better the day, because then all is quiet and the heat does not become a disturbing factor; fine rain without wind is also an advantage because it moistens the feathers. For a journey with a falcon such weather is desirable in spring, summer, and autumn, and, except for the rain, also in winter.

Hail is harmful at all seasons because it strikes and irritates the falcon and it is usually accompanied by a strong wind. A pouring rain seldom occurs without wind, and this combination wets the captive bird too much. Snowstorms, without wind, occurring in spring and autumn are less hurtful than hailstorms and pelting rain.

If bad weather overtakes the falconer when on horseback and he sees that it will soon pass over, he may seek the protection of a tree or some other shelter; and he must not screen himself³ but in preference to himself shield the falcon as much as he can with his body and his hat, holding her close to his breast. If the storm comes from the front he should turn his back to it and, if there is no other refuge at hand, wait in that position until the storm is over.

Since the falconer may be unable to avoid travel in stormy weather, we shall again refer to its worst aspect—the wind. Gales that blow on the back of the falconer are less disagreeable than others, because the falcon is protected by his body. She may be carried upon either the right or the left hand, and can be held against the falconer's breast, where hail or heavy rain, coming from the rear, will drive across her back without touching her. Also, since the travelers are moving with the

³ Bologna MS., fol. 61^v, col. 1, *Et se non protegat, sed defendat falconem*; Vatican MS., fol. 100^v, col. 1, *et si non, protegat et defendat falconem*.



PLATE 87.—Hawking costume of a young nobleman of the reign of Henry III, 1250
(after Atkinson)



PLATE 88.—Falcon's hoods, sixteenth century (Hohenzollern Museum)



PLATE 89.—Elector Clemens August of Cologne (1723–1761) and his favorite falcon. (Courtesy of Dr. Walter Schlüter)



PLATE 90.—The Mogul Emperor Jahangir and a favorite falcon,
1600 (Museum, Berlin)

wind, it strikes less violently than when going against it. A wind coming from either side is less serious in its effects than a head wind, but care must be taken to place the falcon on the left hand to face a wind coming from the right and on the right hand in a gale blowing from the left. The more directly the breeze blows from the front the more harmful it is, because the falconer then finds it impossible effectively to shelter the falcon with his body.

CHAPTER LXXIII

ON TRANSPORTING FALCONS THROUGH VARIOUS REGIONS

Some localities are not as good as others for this purpose. In every season it is desirable to carry the falcon (untamed and seeled) through a wood. Whether it is hot or cold, in hailstorms, snow, or rain, the falcon is less exposed in a forest—and by this we mean among high trees.

Plains also form a good terrain, when they are windless; but whenever there is wind hilly localities are to be preferred because a gale has less force in the intervening valleys. Hill-tops and other exposed, elevated areas are to be avoided during stormy weather; so are underbrush¹ and shrubs, because of the rustling noises made by the passing wind;² moreover, low bushes afford no shelter for the falcon from storm, rain, or sun. Rushing water is to be shunned, because a roaring sound frightens the falcon. There would be no objection to towns and villages were it not for the din made by passers-by—animals and other creatures.

When a half-seeled falcon is to be carried about from one place to another she must

¹ *nemora dicimus de minoribus arboribus*, Bologna Codex, fol. 62, col. 1.

² Bologna Codex, fol. 62, col. 1, *ex gressibus ventorum*; Vatican Codex, fol. 101, col. 1, *ex gressibus equorum*.

once more be entirely blinded. This precaution is taken so that she shall not see objects that will frighten and make her unruly. If she has advanced in her taming so far as to be permitted full vision in the mews, she should be made only half-blind before beginning the journey. Were she to be fully seeled she might become wild again and entirely forget what training she has had, and if left entirely unseeled she might be injured by bating and restlessness.

When the falcon has been half-seeled, in the manner described, she may safely be transported; but the emergency ration and other quieting devices should be employed frequently, because she is more likely to bate, while on a journey, than is a completely seeled bird.

If the excursion lasts so long that it becomes necessary to renew the stitches in the lids of a seeled falcon, the operation thus repeated (particularly if under unfavorable conditions) may so excite the bird as to make her hate the operator and, perhaps, in her struggles, permanently damage her eyelids. It is then better to delay the procedure, to relax the seeling suture,³ and to treat the situation as if she were at home and during the journey to tame the half-sighted bird in the hope that (eventually) she may be given her full eyesight. Although this plan presents difficulties, because force is, as a rule, required rather than technical skill, it may be unavoidable in the present instance, owing chiefly to the fact that it is not possible on a journey to take advantage of the resources and care available at home. It must be added that the sighted bird should for several days be carried at nighttime. Later, the falconer may rise before daybreak and arrange his journey so that he can reach a desirable shelter by sunrise. In this way, he may safely and gradually increase the amount of travel dur-

³ By "relaxing the sutures" the Emperor means to loosen the threads so that the bird becomes half-sighted.

ing daylight hours. Meantime, the falconer should always have on hand the emergency rations to be presented whenever there are signs of unrest on the part of the falcon.

Although it is desirable for seeled falcons to be transported through heavily wooded hills and valleys, since their blindness does not then trouble them, this is less true of sighted birds, who dislike forests and valleys and prefer high land, whence they have good distant views.

When the falcon thus taken on a journey has been tamed in all respects, except for entering her to the lure and other more advanced training, she may be carried about anywhere at all suitable hours, whether she be an *eyas* or a *brancher*, the falconer accompanied always by rations, and using other precautions against bating.

CHAPTER LXXIV

OF THE UNREST AND BATING OF FALCONS WHETHER ON THE FIST OR ON THE PERCH

A bird that has not been trained in the order and by the methods described in this work will surely exhibit evidence of that maltreatment, both at the beginning of and during the training period. For instance, when the falconer approaches to lift her from a high perch she will rouse, contract her flight and contour feathers (as well as the plumage of her crown), and stare at the eyes of the falconer. The nearer the latter comes the more she will flatten her plumage. Finally, she will strike at him.¹ When he puts out his hand to unloose her, the bird will jump along the perch or in any other direction away from the man. When she is about to be raised from a low perch or block, these signs are more marked, as if she were still less certain about her safety in that position.

Again, if the falcon has already been placed

¹ *exacuit se contra falconarium.*

on the fist of the attendant, she now stares at him and at others who come near her, but especially at the faces of those who approach her from the rear; and she tries to bate. The bird rarely stands on the fist with relaxed plumage but holds her feathers pressed tight against her body, and she rarely lifts one foot, as is normally the case with the well-tamed falcon. She fails to lubricate her feathers or to preen them with her beak, nor does she rouse as usual when on the falconer's fist but springs down and backward, bating in the worst manner possible. If replaced on the fist she gazes fixedly at the man carrying her and at others about her, even while feeding. When nobody else is present she stares at objects about her.

When the horseman mounts with her on his fist, she bates and her restlessness continues while she is being carried about. She is much alarmed by all her old objects and sources of fear; and when the rider dismounts she continues to be disquieted. Added to all this she is not inclined to take her bath as long as the attendant is near her. If after it she is placed on the fist, she always bates. She misbehaves even when given the emergency ration of good meat, for a wet falcon has less appreciation of or desire for food.

Each one of these difficulties must be treated as a separate problem.

CHAPTER LXXV

FURTHER REMARKS ON REMEDIES FOR THE FALCON'S UNREST AND BATING

For unruly conduct of the falcon while on her roost one may resort to the following remedies: The falconer must offer the emergency morsels frequently, and never go near the block or perch without them, particularly if he intends to lift the bird to his fist. This practice should be continued until the falcon no longer fears her master but takes pleasure in seeing him.

In dealing with the misdeeds of the falcon on the fist, the attendant should remember never to stare at her directly and suddenly, but rather to offer her the emergency ration; and, if he wishes to inspect her, he must hold the tiring before his face until she has become habituated to a full view of both of them; and even then he must direct his gaze toward her gradually.

To quiet a falcon who is restless while her bearer is mounting his horse, let her have the substitute ration each time this act is performed, and let the falconer pay strict attention to the proper method of mounting, following the instructions already given.

To prevent the falcon's disquiet when on the rider's fist, attention must be given to objects that frighten the bird by the way-side and to offering a snack before they are reached; the latter must also be given on dismounting.

The rules governing the bird's bathing, and her encouragement with the emergency ration, must also be observed, as well as the employment of other devices to make her obedient and to accustom her to the near approach of human beings during her ablutions.

When a newly acquired falcon has been badly manned, so that she still fears the sight of a human face (although she has been properly carried), she should be entirely seeled¹ and tamed in accordance with the rules already laid down by us. When, in addition to her bad manning, she is fatigued after a long journey, she should be seeled or half-seeled, according to the degree of wildness she displays, and placed upon the low perch to rest. If she is emaciated she must be better fed, but not too much, else she will be made wild again. After she has recuperated, she should be tamed in accordance with her degree (lack or excess) of wildness.

In the case of a properly tamed falcon—

¹ This applies to falcons trained without the hood.

one not afraid of man or other objects—whom one acquires after a long journey and who is evidently suffering from fatigue and, in consequence, shows signs of bating, she should be allowed to rest in a darkened room, and must even be blinded if her bating is not stopped by other forms of treatment.

Those birds in whom bating is a habit are tired out more quickly than others by a protracted excursion. This is especially true of those who, at the beginning of their manning, were too much reduced in weight.

CHAPTER LXXVI

ON THE FAULTY CARRIAGE OF A FALCON ON THE FIST; ITS SIGNS AND SYMPTOMS

A bird that has been improperly carried on a long journey, or for a long period, indicates that experience in the following way: Her wings hang down and her tail is not held, as it should be, in a line with the back, but she uses it to brace herself against and to strike the falconer's fist. The tail is gathered into a kind of hump at the point where it is inserted into the back. Nor does the falcon keep her feathers in proper apposition; and she stands more on one foot than on the other. Furthermore, she grasps the fist with her talons and braces herself unevenly on it. If the hand is moved, the bird does not dare to alter her foothold because of her fear of falling, but grips the hand even more firmly. Eventually she rouses and makes weak efforts to bate; but she does not fly, she merely stretches out her wings—one or the other, or both. She does the same with her legs. Her eyes have a sleepy look; sometimes she closes one, sometimes both of them.

These signs [of fatigue], that may be observed not only when she is on the falconer's fist but while she is roosting on a high perch, or on a block, are more marked when a properly educated falcon is carried on the fist of

an improperly instructed falconer than when a bird that has always been badly carried falls into the hands of an inexperienced carrier. Never having been the victim of an improper method of carriage, the educated hunter is all the more disturbed by unusual ill treatment. She at once shows the signs of distress just described, and tries to fly away, even if she belongs to the class of falcons that rarely bate. Especially does she show intense dislike of an uncomfortable and improper position on the carrier's fist. On the other hand, the falcon who is accustomed to endure an improper method of portage will often become resigned to this maltreatment, albeit in an apathetic sort of fashion.

Further and certain evidence that the bating and distress of a falcon are due to faulty carriage is clearly noticeable when the bird is changed from the hand of a badly trained porter to that of an educated one; she shakes her plumage and settles down just as she would if she were transferred to a good perch in her mews and thus were assured of a rest for her tired feet and body. She now draws her disordered feathers into their proper positions—an act she also performs on the stool or perch because she knows the new pose to be more comfortable and to afford a firmer position than any hand.

For the treatment of the falcon who has been the victim of improper carriage, but who is so tame as not to be afraid of the human visage and most other objects, one should (without any form of seeling) put the bird to rest in a mews—preferably, for greater security, in a dark room—on a low perch or stool. In winter, cover the surrounding ground with straw, hay, or similar material (in summer sand is best) upon which she may rest without injury to her flight feathers or her feet. While she is in the darkened room, the falconer should visit her frequently and tame her with a ration so that by such means she may not revert to her wild state; how-

ever, when the time arrives for her meals she should be taken out and allowed, while being fed, to be near human beings, so that her previous manning will persist. If she is emaciated, her diet should be so increased as to re-establish her lost flesh; but she should not be overfed, else her former unrest will return. In this last case she will refuse any longer to accept the tiring and will become so restless that she will not profit by the period of rest that she has been given. Then her usual diet, unless she is still too thin, should be resumed, and great care should be exercised that she does not once more fall into the hands of an ignorant attendant, lest all this attention go for nothing.

To recondition either an eyas or a passage falcon, weakened and even exhausted by her efforts to bate because she was not seeled when first captured and has been tamed by an ignorant unskilled in carrying, it is necessary to seel her and tame her anew on a low perch and in a dark room. There she must be fed with fresh meat, allowed plenty of rest, and be given such further careful handling as will neutralize the wretched training she has already experienced.

All such falcons who have had sufficient refreshment indicate that fact as follows: The eyes are wide open, and they appear entirely awake; the wings are raised high and held in their proper position; the body plumage is normally arranged; they stand erect on their feet; they are agile in their movements; they shake themselves vigorously; they frequently and energetically ruffle their flight feathers, and anoint thoroughly and preen vigorously all their plumage with their beak. When these signs are given, the falcon is ready for such further taming as her condition requires.

At times a falcon that has been badly carried for a long period, or on a protracted journey, may be observed to show signs of wishing to go to perch, especially toward nightfall. In that instance she must not be kept any longer

on the hand but be placed at once (before she starts to bate or to give other evidence of distress) on a stool and allowed to rest and recover her strength. The symptoms of such a condition, and directions how to counteract them, will be found in the chapter on the bating of falcons while being manned indoors.¹

CHAPTER LXXVII

ON THE TRAINING OF THE FALCON BY MEANS OF THE HOOD²

Hitherto we have spoken of the falcon and her training without a hood; now we shall take up the subject of that device and consider its use so that, having learned both methods, we may choose that which suits us best.

In the foregoing chapters we have discussed first the unhooded falcon, because it is our older method and because the use of the hood is in this way more easily learned than in the reverse order.

First of all, let us consider the hood itself, its origin, what it is, the shape of a good hood, and how it should be utilized in the case of untamed birds. In this connection one should also study the preliminary treatment of the falcon (before she is allowed to wear the hood), under what circumstances and how the hood is first to be used, the falcon's struggles against its adjustment, and how one meets this last difficulty, especially during and after that adjustment. The falconer must be sure that the falcon does not drag off the hood, and he should be on the lookout for signs that the bird will try to remove it.

The falconer must also learn how the hood is taken off, and for what reasons and when the falcon should go without it. He should

know what birds can be trained to the frequent wearing and removal of the hood and what falcons cannot. He must learn also when the hooded falcon is to have her seeling sutures relaxed or entirely removed, and when she may be safely taken outside on foot and (later) on horseback. He must recognize the restlessness of both wild and tame falcons when it is caused by their head covering; especially must he notice if his attendant is expert in its use or if its shape and size are not suitable for and do not fit the bird. He should know when a change of hood is requisite and how, if possible, to avert dangers arising from its maladjustment.

While investigating the personal peculiarities of a newly arrived falcon, it is important to discover whether she has been accustomed to wearing a hood and if she has been broken to its use by a skilled or an unskilled falconer. If she has been made to the hood by an inexperienced attendant, she must be retrained under the care of a falconer adept in its adjustment.

Finally, we shall discuss the use of the hood when the captive bird is to be taken on a long journey and tell how it differs from its use in the case of a falcon who has no such travel before her; we must consider, also, in what respects the hood may serve the same purpose as the tiring and what other ends may follow its use.

The falcon's hood is a discovery of Oriental peoples, the Arabs having, so far as we know, first introduced it into active practice. We ourselves, when we sailed across the seas, saw it used by them and made a study of their manner of manipulating this head covering.

The Arabian chiefs not only presented us with many kinds of falcons but sent with them falconers expert in the use of the hood. In addition to these sources of knowledge—from the time when we first decided to write a book, a complete treatise (on falconry)—we have imported, partly from Arabia, partly from other countries, both birds and men skilled in

¹ In the Vatican manuscript this paragraph is placed before the preceding one.

² *capellum*.

the art, from whom we have acquired a knowledge of all their accomplishments.

As the practice of hooding was one of the most valuable features of their methods, and as we perceived its great utility in taming falcons, we adopted it in manning our own birds and have given it our approval, so that our contemporaries have learned its use from us; nor should it be neglected by our descendants.

CHAPTER LXXVIII

OF THE FORMS, MANUFACTURE, AND USES OF THE FALCON'S HOOD

The falcon's hood is a cover made of leather, fitted to the head of the bird, entirely enclosing it as far down as the throat, except for an opening to accommodate the mandibles and the nasal apertures. The leather of the hood should be neither too hard nor too soft, and the hood itself must in every respect conform to the shape and size of the falcon's head. It must be so adjusted that the falcon cannot see anything, while the apertures for the beak and nose should be so placed that the bird can breathe freely. The crown of the hood, as well as the portion over the eyes, must be wider than that encircling the throat. This provision obviates hurtful pressure on the visual organs, while the narrower part about the throat prevents the hood from falling off. At the same time the cowl¹ must not be too narrow, lest it be difficult to draw it down over the bird's head; nor should it fit too tight about the parts it covers. There should be one opening in that part of the hood that covers the face, through which the beak and nostrils protrude. It should just fit the beak. The segment that covers the crown should be perforated with small holes for purposes of ventilation, to prevent overheating of the falcon's head and

¹ In old works on English falconry the hood was often called a "cowl."

to allow escape of its exhalations. These small vents we ourselves added to the original hood, for we consider them to be of the greatest value in preserving the health of the birds that wear it. We noticed that when such a provision was not made the falcon's head became overheated; and when the hood was removed, the head, suddenly exposed to the cold air, was chilled and birds thus imprisoned were more liable to catch cold and to acquire diseases of the head. This disadvantage of the hood vanished when we invented this new form of hood and eliminated the sudden change of temperature.

That part of the falcon's hood embracing the back of the head (occiput) toward the nape must taper to a point, and to this is attached a narrow strip of soft leather, long enough to extend over the back of the bird,² between the wings, to the end of the tail.

Before the falconer introduces his hunting bird to the hood, he has other duties to perform—cutting off (coping) the sharp ends of the claws, putting on the jesses and the bells, seeling the bird, and placing her on the fist. If all these preliminaries are not properly looked after, it will be very difficult to accustom her to wearing her headgear.

Opinions vary as to the time and manner of initiating the use of this device. Some authorities maintain that as soon as a wild falcon is caught, seeled, taken out of the falcon sock, and placed on the fist, the hood also should be put in place, even before she is stroked or touched in any way on her beak, breast, or neck. They give as a reason for this rule that the newly caught bird is so frightened and subdued that she will at that time allow the hood to be placed in position and, from that first experience, will soon get accustomed to it and readily allow its future replacement. In the meantime she should be

² As is well known, the modern hood is supplied with ingenious devices for opening and closing this head cover. (See Plate 91, p. 209.)

stroked and made familiar with it in every possible manner until the time comes to re-hood her.

Others, however, claim that the newly captured falcon, when first thrust into the falcon sock and seeled, is so terrified by this treatment that additional attempts to handle her will only make her struggle all the more and resist the subsequent hooding. Hence they advise that for several days after her capture she should have a rest and be gently handled and frequently stroked with the hand, a rod, or feather, over the head, throat, and breast before attempting to put on her hood.

Our own opinion is that some falcons are so overcome by the terrors of their capture and subsequent seeling that they do not resist the further imposition of the hood, for example, the sakers and the lanners. On the other hand, there are birds of prey who, after they have been captured and seeled, are in the highest degree refractory and are so wild that it is practically impossible to hood them immediately. One can decide to which class a recently caught bird belongs by noting (shortly after she has been taken, seeled, and stationed on the fist) whether the feathers on her head and throat and the rest of her plumage are closely pressed against her body and whether or not her wings are drawn up on her back. When she is touched on the head or beak, if she does not open the latter or spit (hiss), and if she does not shake her head and the feathers on her crown and throat are not ruffled, then she is subdued by terror and may be hooded at once, before attempts are made to tame her; but of this class one meets few examples.

A falcon that does not answer to the foregoing description is innately wild and must be gently handled, stroked, and tamed by various means for some time before trying to hood her—at least until she ceases to open her beak or to ruffle her feathers when touched by the hand.

CHAPTER LXXIX

OF THE PROPER PLACE FOR AND MANNER OF HOODING THE FALCON

At first the hood should be adjusted in a dark room, for although the bird be entirely blinded she none the less perceives daylight and may, for this reason, struggle against hooding. This work should be done also in an isolated mews where the falcon cannot hear strange noises or voices, because these sounds will make her resist all the more the wearing of her hood.

In the actual placing of this cover on the falcon's head the jesses must be pulled short and firm, so that the bird is secure on the fist. The falconer then holds the hood with his fore and middle fingers placed in such a position that the segment corresponding to the back of the head lies on the inner side of these two fingers and the aperture for the beak is uppermost. The thumb should lie next this opening but in such a way that this slit does not come between the forefinger and the thumb.¹ The leather strip (at the posterior part of the hood) must project from the inner to the external surface of the hand so that the two fingers mentioned are on one side of the strip and the other two on the opposite side. To put on the hood it should be so held that the lower aperture (through which the head must be thrust) is opposite the falcon's face, and so presented that the beak slips easily into its special opening, which should never be covered by the thumb, thus impeding the adjustment of the hood.

The ring and little fingers, which do not support the hood, the falconer employs to prevent the bird from being pushed backward or otherwise disturbed while the hood is being put in place—an accident that often happens.

¹ That is, above the opening.

There are falcons who, in spite of the exercise of all these precautions, try to avoid the cowl and show anger and unrest even at the sight of it. Therefore it should be adjusted as dexterously as possible, that the falcon may not be exhausted, form the habit of bating at the sight of the hood, and grow to hate the falconer.

The leather strap on the back of the hood, which has been held between the two upper and the two lower fingers, must be gently placed along the center of the bird's back between the wings and allowed to hang down between the tail and the wing that is farthest from the falconer. In this manner the tail maintains a position between the leather strap and the falconer, who should now hold the end of the thong between the outer fingers of the hand that bears the bird. He does this for fear the falcon may loosen the hood from her head. But the falconer should not hold it too tight, lest it irritate the captive bird, who may then turn her head around, seize the strap with her mandibles, and try to tear it off; or, if she thinks she can grasp the strap at the middle of her back, she may attempt to do so and instead pull out some of her feathers; or she may attempt to rid herself of the leather altogether by shaking her head frequently and wind up by springing off the falconer's fist.

In case the hood is dislodged, either by the falcon's violent head-shaking or by her scratching it off with her powerful talons, it will not fall to the ground if the leather strap is held firmly between the fingers.

If the falcon does not object to wearing the hood and it fits so well that she cannot shake it off, it is a good plan not to hold the leather thong between the fingers but to allow it to dangle beside the captive bird's neck instead of resting on the back between the shoulders. One may also use this strap to fasten the hood, when not in use, to the falcon's perch and thus preserve it.

CHAPTER LXXX

ON OBJECTIONS TO THE HOOD ON THE PART OF THE FALCON AND HOW TO DEAL WITH THEM

The strong opposition by a hunting bird to having a hood placed on her head and to the subsequent wearing of it is easily understood; the whole scheme is contrary to her nature and, in consequence, she is restless under these alien conditions.

Some falcons resist the adjustment of the hood but are quiet once the operation is complete. Others do not resist attempts to hood them but appear to object strongly when they realize the results. Such instances are very rare. We must, therefore, study the nature of each falcon's resistance to hooding and her efforts to remove the cowl, so that we may teach her to submit quietly to its use.

Stubbornness in this respect reveals itself by the following signs: the falcons are not quieted by seeling but open their mouths, spit (hiss), ruffle the feathers of the head and neck, and, despite their blindness, feel for and attack the hood itself, because they hate the touch of it and (probably) have a sensation of tickling. Many birds show their aversion in many fashions, others by a few only; in some their dislike is persistent, while still others compose themselves, resigned to their fate.

A falcon that opens her mouth, hisses, and shakes her head and neck should be softly stroked, with the hand, a feather, or a wand, over the throat, neck, and breast to accustom her to the touch not only of the human hand but to the presence of the hood and to show her there is no reason to worry over any tickling sensations due to the head covering. The falcon should now be habituated to the frequent removal and replacement of her head-gear, as well as to frequent touching of her beak, neck, and breast.

After the hood has been placed on the fal-

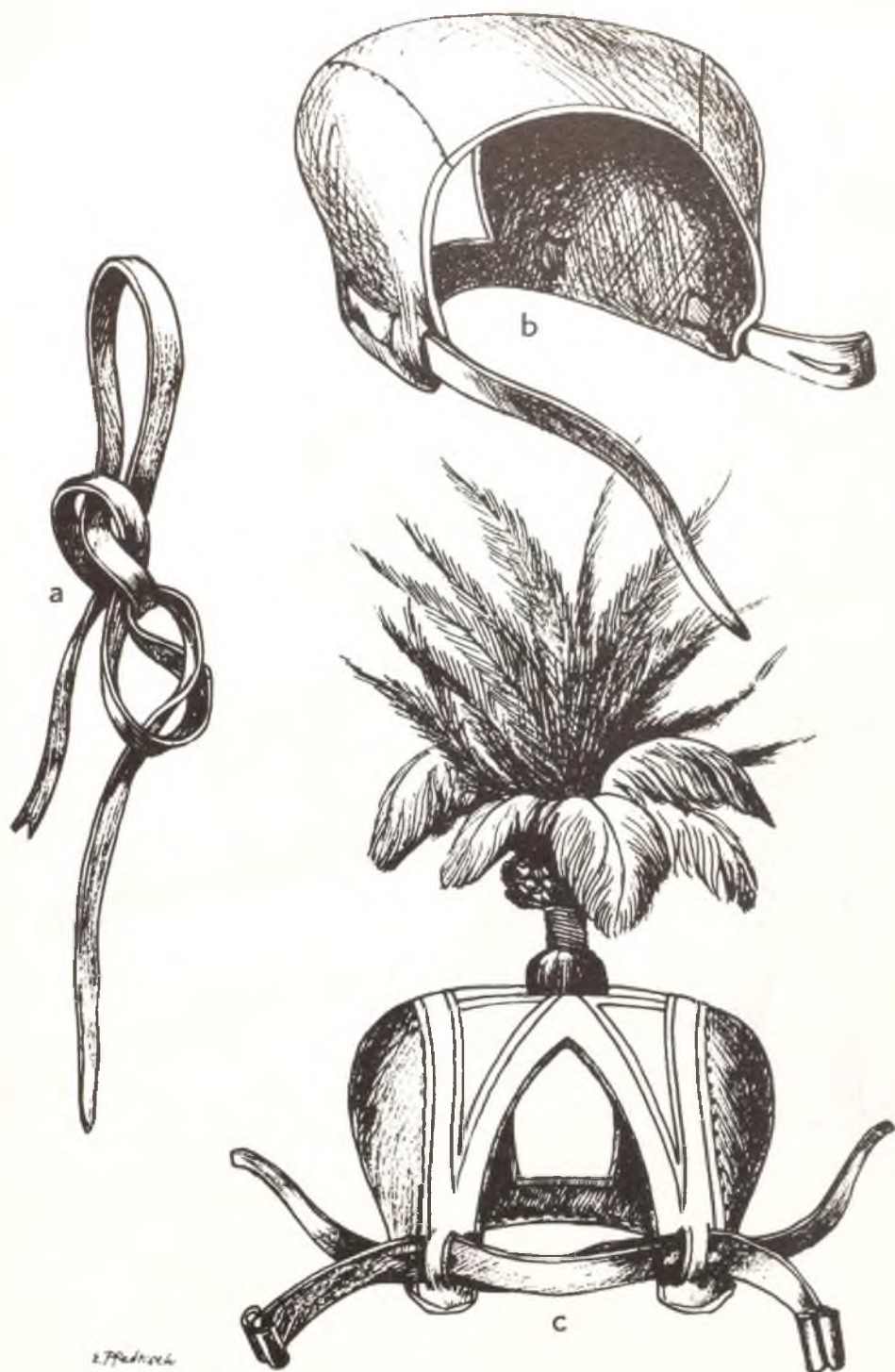

PLATE 91.—Hoods and their arrangements: (a) falconer's knot; (b) one-piece (Newcome) hood; (c) decorative Dutch hood.



PLATE 92.—Norway falcon. Adult male (after Brodrick)

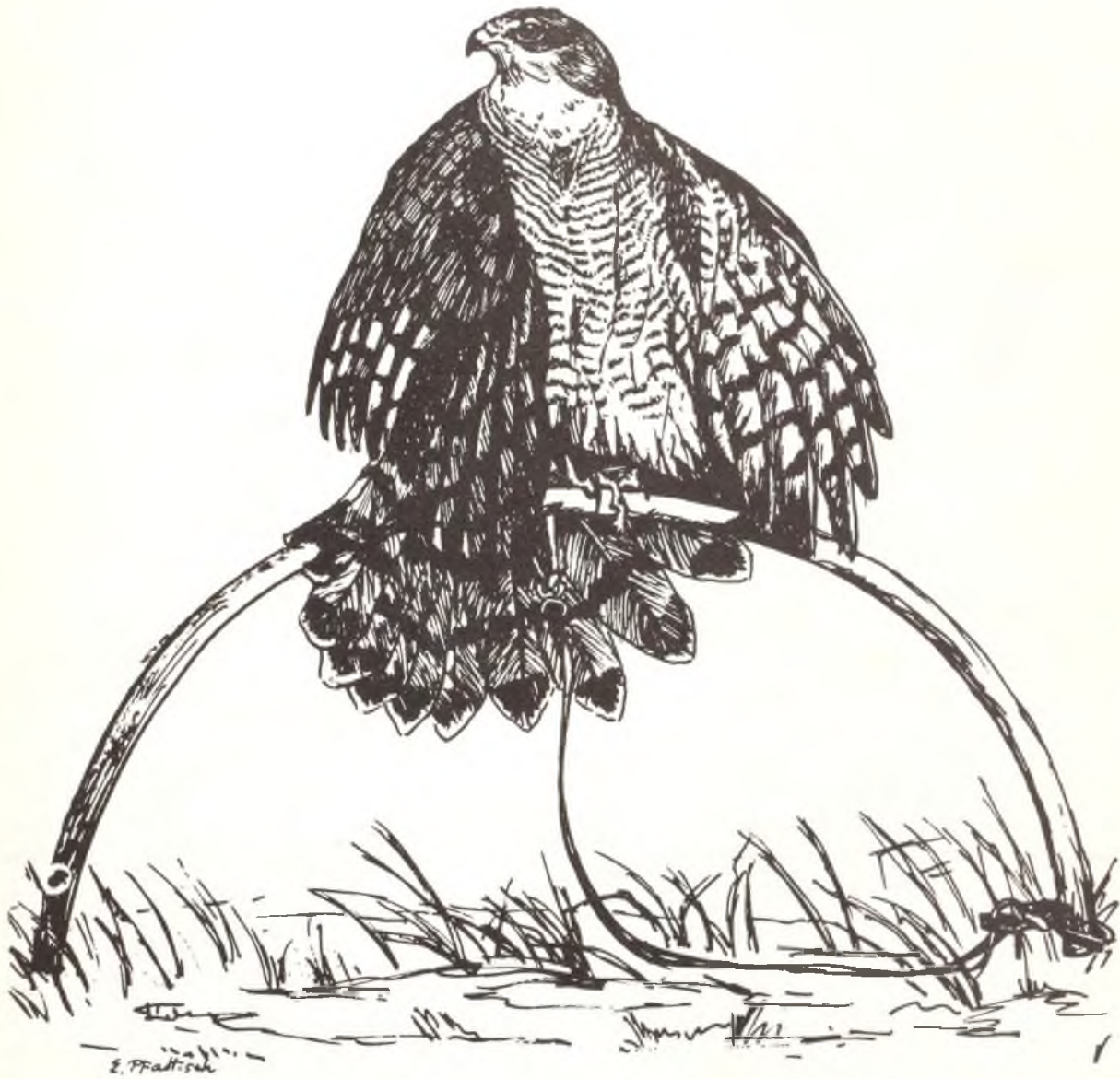

PLATE 93.—Sparrow hawk. Adult male (after Salvin and Brodrick)



PLATE 94.—Greenland falcon. Adult tercel

con's head she may at once shake her head violently, as if trying to rid herself of the cover; she hisses and screams, jumps off the fist in any way she can, and makes no effort to regain her position. If replaced, she bates again; while she is on the falconer's hand she clutches it with her sharp talons, bites her jesses and the carrier's glove, tries to grasp the hood with her foot, and if she succeeds in this attempt may easily pull it off. Some falcons show more, others fewer, signs of unrest due to the wearing of the hood. During this period of disquiet one must take precautions against the bird's tearing off the hood. The posterior leather strap should be held firmly between the fingers (as already described), and, when the falcon begins to shake her head or if she attempts to remove the hood with either foot or to scratch herself with that intention, the falconer should grasp the jesses still shorter and tighter, should place his finger on the hood in front of the bird's forehead (to hold the hood in place) and if need be rotate the hand on which the falcon stands. There, as she is not sure of her position on one foot, she will be obliged to lower the other, and cease her useless acts.

If she bates and will not of her own accord return to the falconer's fist, she must be pulled back to it, the falconer assisting her with his free hand; and if she begins to bite, some hard object should be tied on her mandibles. She will then not repeat that trick.

Falcons that continue to be refractory and manage to remove their hoods should be left covered for long periods, and frequent attempts to hood or unhood them should not be made.¹ When they are wearing the hood, they should be left quiet and not touched.

¹ The six-book and two-book editions differ at this point. Bologna MS., fol. 66, col. 1, reads, *istis tamen qui se multipliciter inquietant sub capello deiciendo capello in capite suo diu et non frequenter imponendo est eis capellus aut removendum*; whereas the Vatican MS., fol. 107, col. 2, says, in part, *diu dimittendum est capellum, et non frequenter*, etc.

From the foregoing it is evident how best to meet the difficulties presented by falcons that either resist the imposition of their hoods, or are restless when wearing them, or that suffer from both defects. The signs that the falcon is no longer displeased with her hood are that she occasionally shakes it, rearranges and anoints her feathers, and holds the falconer's fist lightly and does not try to sink her talons into it. She sometimes goes to sleep with her hood on, especially after she has been awake on the falconer's hand for a long time or is hungry or tired.

To remove the hood, take hold of it on both sides of the forehead, using pressure only sufficient to draw it off slowly and gently.

The bird is preferably freed from her hood while she is feeding, when she is offered the emergency ration (or a piece of cold wing), when she is placed on the block or on a perch, or simply in order to give her a rest. Furthermore, the hood is not required if the falcon is perfectly quiet, when she is taking a bath or when she is loosened to fly at prey. If she is for any reason restless, she should not be unhooded² until she has been quieted; for should her head covering be removed while she is disturbed, she will quickly learn to use that method of getting her hood taken off. If she is quiet when first her hood is removed but later becomes restive, the falconer should not encourage this vice by keeping her unhooded but should replace the hood until she has learned to remain unruffled when free of her head cover; else she will thereafter be subject to fits of unrest and wildness.

Frequent trials of the hood should be employed only in training those falcons that at first violently oppose its adjustment but not those that are restless under it. As a rule, those birds that object both to taking off and putting on the hood, eventually (by frequent touching of their mandibles and head with the

² The Vatican MS., fol. 107, col. 1, omits the rest of this sentence. Cf. Bologna MS., fol. 66, col. 2.

hood) become accustomed to the irritation caused by these acts. As for those falcons that do not oppose the putting on of the head covering during its frequent employment, special training is not at all necessary.

Seeling threads should not be loosened to give a falcon half-sight until she has given up resistance to the act of hooding and remains quiet while her head is covered. Should she accidentally become unseeled, the damage should at once be repaired. When she has become accustomed to the hood she can be half-sighted, so that she may gradually grow used to seeing the hood, as well as the falconer's hand moving about to place it on her head.

Among the evil results of a too early restoration of vision is that the sudden sight of the hood, along with the hand and face of a man, is likely to make her wilder than ever. It is true that she may have seen these objects in obscurity; but complete and distinct recognition of them is new to her and serious results may follow. If she has suddenly been given full vision, there is even more danger that she will be frightened into all kinds of unrest and bating.

The half-seeled falcon must be tamed to the hood in the same manner as when she was entirely sightless; she should be taken into a dark chamber, where she will only dimly see the trainer's face and hand, and the hood is frequently put on and taken off. Were she to see clearly she would turn away her head, open her mouth, and show other evidence of unrest. In such cases it is quite plain that it is not the hood itself that is the chief cause of the falcon's restlessness; otherwise she would continue to be unruly after the hood is placed over her eyes.

After the falcon has been thus trained in a darkened room for a number of days, so that she is sufficiently pacified, she should be transferred to a part of the mews that is better lighted, then into a well-illuminated chamber, and, at last, carried about outdoors both on

foot and on horseback; and when she has been amply trained to the hood she may be granted the full use of her eyes, and the same plan adopted as when dealing with her as a partially seeled bird. Each step of the scheme must be carried out in the same order with respect to localities, degree of lighting, and forms of transportation.

When the falcon is restored to complete vision, one must remember that outdoors she will, every time her hood is removed, see many things that she never met with inside the mews and that fact may at first stir memories of her former freedom. This will tend to make her restless, and she may bate; hence the falconer ought to take precautions against this contingency. For this purpose he should offer her the emergency ration now and then and, while she is eating it and is becoming less flustered, put on her hood. It is well to sprinkle her frequently with cold water, especially while she is wearing her hood, and to give her frequent baths, at the same time removing her hood. In this way the sighted falcon will soonest be made to accept her headgear, both indoors and out, and her opposition to wearing it will best be allayed.

Both a wild and a tamed bird will often refuse a hood at the hands of an ignorant falconer, particularly if it does not fit the head or if she is made to wear one to which she is not accustomed. After a sighted, a half-sighted, or an entirely seeled falcon has grown accustomed to the hood, it is bad practice to entrust her to a man who does not understand that the use of unskillful methods, either in putting on or taking off the hood, may ruin the bird or make her more difficult than ever further to tame, train, or utilize. It is bad enough when this happens to a falcon already trained to wear the hood; but it is a far more serious affair when a wild bird falls into the hands of an assistant who does not thoroughly understand the first principles of hooding birds of prey.

The falcon will not tolerate nor rest quietly under an ill-fitting hood but will resist attempts to make her wear it. When the cover presses too hard on any part of the head, especially if it touches the eyes, it will be noticed that the bird rubs one or both sides of her head on her shoulder, the exact spot depending upon the position of the irritation; and it will be found that the interior of the hood is wet from the tears that escape from the bird's eyes.

If the hood grates on the falcon's beak, she will open wide her mouth, shake her head, and gape as if she were going to vomit. With her talons she will scratch the mandibles where they are irritated, and there frequently appears on the upper part of the nose a red swelling, accompanied by some loss of feathers on both sides of the fauces. If the cowl presses on the throat, the bird ruffles all the feathers in that region, so that the gullet seems swollen; and she continually attempts to pull off the hood.

A falcon accustomed to wearing a hood is not always quiet when her headgear is changed even though the new one fits well. This unrest is nothing to be worried about, for it arises simply from a new sensation and is not at all similar to the restlessness of a wild, freshly hooded falcon that has had no experience of the hood. Both tame and wild birds, however, resent the new hood seriously if it is ill-fitting.

The only remedy to offer a falcon against an inexpert falconer, badly trained in the use of the hood, is, as we have said, to see that neither a falcon who is new to the hood nor one already accustomed to it be entrusted to an ignoramus for training; and if a bird has already suffered in this way she is to be treated as we have explained. There is no remedy for a really ill-fitting hood except its exchange for one that is without a flaw, especially one that does not improperly press on or irritate the head or throat of the bird that wears it—such a form as we have already described.

To avoid changing the hood—an act that always brings more or less dissatisfaction to the bird—try at the outset to choose a hood that has already been used and is of good form,³ one that will not later call for an exchange. If it is necessary to change the cowl, see that the new one is of equally good shape; and avoid frequent changes.

By the following signs one may learn whether or not a newly acquired falcon is accustomed to wear a hood and whether she has been under the care of an expert or an inexpert falconer. A bird that has never worn a hood may permit herself to be hooded without a struggle but once it is on will generally resent it and become restless. A bird that is already reconciled to wearing the hood and has had expert handling will permit herself to be hooded without opposition, and is quiet afterward, since she has been well educated. One who has been trained by a poor falconer fights against the hood, because she has experienced bad handling in adjusting it; but she is quiet afterwards as she gets used to it under the supervision of an expert trainer.

Falcons that permit themselves to be hooded easily at first and become restless later must be treated as if they were being broken to the hood for the first time. That a newly acquired falcon makes no resistance to hooding and is quiet afterward is proof of her good training. Those birds that have suffered at the hands of a clumsy trainer for some time should be re-seeled, and afterward treated gently and hooded with as great care as possible, so that they may forget their previous inexpert treatment and experience only proper methods carried out in the order already prescribed. In other words, one should guard against the acts of an unskilled falconer and the evil results of a badly fitting hood. Following these rules, the falcon whom it is not planned to send immediately from

³ One that conforms with the rules laid down in chapter lxxviii of this Book, p. 206.

one region to another can be made familiar with her hood both indoors and outside the mews.

When⁴ one is about to take or to send falcons on a journey, the newly caught birds must be first blinded and then hooded. If it be argued that seeling alone is all that is required while traveling about the country, the answer is that ciliation alone will not keep out all the disturbing light-rays, both because the lower lids cannot be kept raised sufficiently to act as a complete blind (the restraining sutures often stretch or the feathers beneath them become compressed, or else the eyelids sag on either side of the points of insertion) and because some light filters through the thin tissues of the lids. Although the head is less encumbered without the hood, the falcon is more easily disturbed by the stimulation of fresh air and the open country. When worn, the hood covers the entrances to the ears and so deadens those noises that, if distinctly heard, might easily disturb the tranquillity of the falcon.

Before starting out on a long journey the bird should, for a few days, be made familiar with her hood until she either ceases her restless activities altogether or at least abandons the worst of them. She should also be handled and carried about more than if she had no journey to make.

When an excursion is undertaken in summer and in a warm locality, it is better to travel at night, since during the extreme heat of the day the bird's head (under the hood) and her whole body may be overheated and the seeds of disease be planted in her system. Of course, the use of cold sprinkling and bathing will, to some extent, mitigate or prevent these evil results; but a proper supply of pure, cold water is not always to be had at the right time. Al-

⁴ In the opinion of the translators this paragraph should mark the beginning of a new chapter; but, since we are following Velsler in this respect, we omit any such break in the text.

though she shows fewer signs of distress under the hood than without it, she is to be sprinkled nonetheless, on account of the heat. It is also more desirable to take long journeys by night because, at times, owing to the darkness, the hood may be removed altogether; hence the need of having the bird accustomed to its removal and replacement easily and at all times. When, however, it is not possible to transport the falcon through a hot country by night, the falconer should travel only very early in the morning and quite late in the evening—during the coolest hours of the day—and never during the hot midday. During this period the falcon should be fed small but repeated meals and have her meat moistened with cold water. Large and less frequent repasts would harm the bird.

In autumn also it is better to pursue a journey at night with the hooded falcon; for, although it is as a rule cooler during the daytime at this season than during the summer, yet there are always hot autumnal days that should be avoided.

In winter transport is best during daylight hours, because one need not fear the bird's disquiet due to blinding light from the sun, inasmuch as she is at that time wearing her hood. The clear, bright nights that one encounters in the winters of some countries are very cold, and these should be avoided just as much as the great heat of summer. As we have already directed in the case of birds traveling without the hood,⁵ the falconer should wear a fur-covered glove, by means of which the feet of the falcon are kept warm. This precaution, along with the hood, insures the comfort of her whole body. Other provisions against cold, recommended for unhooded falcons, should be observed for those whose heads are protected.

These rules regulating travel with the falcon in the autumn apply also to a journey undertaken in the spring.

⁵ Book II, chapter lxxii, p. 196.

Having discussed the weather to be chosen for travel with the unhooded falcon at various seasons of the year, we now say a few words concerning weather conditions that affect hooded birds.

A clear sky is not unsuitable for a falcon with her hood on, because she is not directly exposed to sunlight and, of course, is not affected by it. Every falcon that is carried with her hood in place is not so much troubled by winds, because the hooded falcon habitually draws her wings and contour feathers close to her body and thus protects herself. In other respects there is but little difference in the effects of weather conditions on hooded and unhooded birds.

What has been said of a choice of locality for seeled falcons applies all the more to hooded birds. The remarks about a transition from seeling to half-seeling, or a complete restoration of the unhooded falcon's vision, are also true of hooded birds, inasmuch as in both cases their taming (and training) can be carried on successfully while they are on an extended journey, when prolonged seeling becomes undesirable.

If a falcon transported on horseback loses her hood and it falls to the ground, owing to an imperfect hold of the fingers on the hood-strap, various situations arise. When the bird is not seeled and is still so wild that she will not remain quiet, the horseman must give her an emergency ration and ask an assistant to recover the hood. The rider must then go a little distance from where the hood lies, turn his horse so that he may take the hood in his disengaged hand, and replace the head covering. The attendant must take care not to approach the falcon from behind.

If the falconer is all alone he must give the falcon a ration, carefully dismount, rescue the lost hood and replace it, and again mount his horse. The falconer on foot may either have a dropped hood handed to him or recover it himself. If (happily) the bird

is accustomed to hooding and unhooding, this procedure will not be a difficult one.

There still remain for consideration the reasons for believing that the hood and the emergency rations serve useful and similar functions, though under different circumstances. Both of them assist in training and manning the falcon and enable one to avoid many sources of disquiet. Also, they are both conducive to the well-being of the bird and to the preservation of her feathers, and through their pleasing effect on her senses lessen her unruly acts. Moreover, they may be used for every kind of hunting bird. They differ; for though they serve the same purpose, they accomplish it by different means and different routes. The hood prevents certain forms of unrest by darkening the falcon's vision, while the sight of the ration stimulates her desire for food and diverts her attention from human beings—an instance where a view of the hood would be ineffectual.

Under the inducement of morsels of food an uncovered falcon will permit the approach of the falconer, and she may more readily be removed from her perch than when simply hooded. She is rendered also more friendly to man and, in the same way, her flight feathers and her talons can be better treated when they are injured—a subject that will receive attention later. With the assistance of an emergency ration, also, necessary work about her feet, such as changing jesses and adjusting her bells, as well as giving medicine and performing other duties the falcon dislikes, will be more successfully accomplished than by the aid of the hood.

The hood, on the other hand, has its advantages over the tiring, when the need of shutting off the falcon's eyesight is urgent. If the bird, because of overfeeding, wildness, or fright, declines the ration offered her and is decidedly unruly, her unrest is best reduced by putting (or keeping) on her hood. If the cowl alone is employed for this purpose it is

generally better for her health, since frequent gifts of food, in addition to regular meals, add to the chances of overfeeding and its consequent evils. The hood obscures the eyesight and, in many cases, puts an end to the bird's unrest in such a fashion as the ration cannot. The hooded falcon allows herself to be handled more readily than does the sighted bird, because the former cannot see the hand that touches her, and this is not possible with the sole use of a ration with an unhooded falcon. Furthermore, when it is necessary temporarily to give a falcon in charge of an inexperienced assistant, it is much better to keep her quiet by hooding than by depending upon emergency rations of whose proper use he has no knowledge. It is, on the whole, easier for an untrained man to hood and unhood falcons than properly to feed them emergency rations. Falconers can divide and give several birds their shares of food in the presence of one another better when they are hooded, since one bird does not see what the others are eating and does not attempt (as she might if unhooded) to seize the quota belonging to the others.

Two hooded falcons can, when required, be borne on the same fist, but they could not possibly be induced by rations to remain there quietly when unhooded, as they would certainly quarrel over their food and injure one another. Should it happen that one of two falcons carried on the same fist⁶ is lost (or should a second falconer lose his bird), the assistant, keeping the remaining hooded falcon on his hand, while using the lure and making the familiar calls, can more readily recover the wanderer. She may then be carried on the same fist together with the other falcon. So long as they are hooded they will neither be restless nor injure each other. This feat cannot be accomplished by use of the tiring alone.

Whenever the falcon must be transported

⁶ The Vatican Codex ends at this point, fol. 111^v.

from place to place over long distances, she may be carried daily with greater ease when hooded, especially if she has been caught wild during the moult. For then, because of her excessive restlessness, she cannot be carried unhooded without injury to herself, nor can tiring (especially the meat ration) be given her throughout the day. If it is necessary to take her from the mews and carry her on a journey before she has finished moulting, she is more easily transported when hooded than by relying entirely on the use of the emergency ration. The latter would be of no avail, for she must be carried either in a fleshy condition (as she is taken from the mews) or reduced in weight along the way. In the first case, the tiring is of no use, as she will refuse it, not being hungry, and in her wild state will bate and be so disturbed that she may injure her plumage and become exhausted. If it is desired to reduce her diet and her weight while on the journey, so that she will have a craving for titbits, although she may be quieted in this manner, she will suffer a deterioration of her growing plumage through insufficient nourishment.⁷

When an unhooded falcon is taken out to hunt, the following difficulties may present themselves: The bird at which she is to be flown may be in open country, where it can be seen at a great distance by the falcon. One must then give her the tiring until a point has been reached from which she may be flown at her prey. If it is not given, one runs the risk of her seeing the possible quarry; and if she does she will become so exhausted from her anxious efforts to be free to fly at it that when she is finally released she will either have lost her desire to pursue it or be so fatigued that she is unable to overtake it; and even though the falcon should accomplish this task she would not be able to hold her victim, especially if it is large. On the other hand, should the prey see her enemy first

⁷ "Hunger streaks" will develop.

and perceive her suspicious movements, it would not wait to take flight until the falcon is slipped in pursuit. Moreover, if the (unhooded) falcon is given a tiring while she is being carried to a position suitable for casting her off, the titbit may or may not be of fresh meat. If the latter, it will not be sufficient to distract the falcon from her restless desire to fly at the bird she has seen. If it is of good meat she will eat so much that she will become sluggish and have less appetite for the quarry she is to pursue; and when the titbit is taken from her she will be so absorbed in watching the hand that removes it that she will have no desire to fly at her possible prey. Also, when she is cast off, the memory of what she has eaten will make her less anxious to follow for long the fleeing bird. All these unfortunate events would not occur if she were taken all hooded to the place where she is to be flown.

What we have said reveals the advantages of the hood and its superiority over the tiring as a means of taming and flying falcons. Therefore this method of manning is to be urged. It is even more to be commended when used in conjunction with the tiring. Training without the hood is to be thoroughly condemned. In other words, the hood and the emergency ration each have their functions; and one is complementary to the other, so that the use of both brings about more rapid and successful manning than either alone. At the beginning of her training, the falcon, through tasting the emergency ration, first loses her natural horror of man and develops an affection for her master; then the hood quiets her restlessness, maintains in good condition her members and feathers, and preserves her vigor.

Training with the hood is precisely the same as that performed without a head covering; the hood alone is added. At the present day the hood is in more frequent use in the training of falcons than in taming short-

winged hawks (*Accipitres*). For that reason we have given instructions for its employment with falcons; and we may add that the hood can be used in the same manner with all other raptorial birds that are employed in hawking.

We have now completed our instructions for the manning of a falcon, both without the hood (chiefly through the use of the tiring) and with that headgear, to the end that she may overcome her natural aversion to man and remain quietly among human beings, even though a confined prisoner. Neither system is to be hastily applied, and each step must be taken slowly and in order. The more gradually progress is made, even though it wearies the falconer, the better it will be in the long run. A falcon, through her wildness, fear, or other adverse condition, may fall into some vicious habit. This frequently is caused by hasty training and may be avoided if she is manned by degrees and for a considerable period. Through this method of instruction (which we much prefer) a falcon loses her fear of man and his surroundings by long association, and is less inclined to bate than when manned rapidly. Moreover, through following our method, falcons are kept in better health and plumage. Also we have found that when birds tamed in this manner are lost and remain in the open all night, whether or not they find food to eat, they are more easily recovered than those falcons that have been hastily trained. Furthermore, when a falcon thus tamed has taken some small bird that she can easily carry (whether she is slipped at it or chases it of her own free will), she will wait more patiently for the approaching falconer. Her fear of a man (when she has associated with him for a short time only) leads her to carry off her quarry to feed upon it and makes her more difficult to recapture. It is thus demonstrated that any hurried manning of a falcon produces results inferior to those obtained by gradual methods.



PLATE 95.—Doorway in the courtyard of Castel del Monte; above it the remains of an equestrian statue of the Emperor under a canopy or baldechino.



PLATE 96.—Fragment of the original twelfth-century ceiling of the Capella Palatina (built by King Roger II) in the Royal Palace, now in the National Museum, Palermo



PLATE 97.—Group of pillars in the cloister of the Cathedral of Monreale built by William II (the Good). The intricate, carved patterns are remarkable for the rich mingling of birds and beasts, leaves and flowers.



PLATE 98.—General view of the terrain surrounding Castel del Monte, so favorable for hawking in the Emperor's day. It is taken from the steps of the main doorway of the castle.

BOOK III

ON THE USE OF THE LURE; ON TRAINING FALCONS TO FLY IN A CAST; ON EDUCATING GERFALCONS TO FLY AT CRANES; AND ON HOUNDS USED IN FALCONRY

AUTHOR'S PREFACE

UR PURPOSE, as we stated at the beginning of this treatise, is to discuss that form of venery carried out by means of birds of prey trained to catch other birds. Since rapacious birds are wilder and more fearful of man than most species, in order that the falconer may hunt with them they must be induced to abandon their natural aversion to him before they are sent in pursuit of their prey. Moreover, as they are not always successful in taking their quarry and do not, chiefly because of past experience, return to their master, they not only must be taught with the greatest possible skill to forget their instinctive dislike of man but also must be trained to return to the falconer even when they fail to seize their prey. This last task is best accomplished as soon as they are completely manned and before they are flown at quarry.

Success in this aspect of training is impossible without proper instruments and the application of certain methods of instruction. We shall therefore first describe the various devices used in this part of the falcon's education. And since the gerfalcon is the most noble of her race, as was demonstrated in Book II of this work, we shall begin with a consideration of that falcon and, in doing so, touch upon the different instruments used by

various people, as well as the diverse methods employed by them for training purposes. When we have done this we shall be able to select and adopt the best.

CHAPTER I

ON THE LURE MADE OF WINGS OF THE CRANE

The two appliances we consider most necessary for our purpose are the lure and the crane. The lure is a symmetrical arrangement of wings by means of which the falcon is induced to fly back to her master. As the crane is the best-known quarry at which falcons are flown and as the gerfalcon is the most noble of rapacious birds, the most skilled in catching cranes, and gives her finest performance in flights at them, we properly choose a lure made of a crane's wings; for it seems best to make the lure of the wings of the bird at which the gerfalcon is usually trained to fly.

The wings of the crane must be cut from the body, not at the first joint (that which articulates with the shoulder), but at the second, that corresponds to the elbow in man. The incision should be made in such a manner that the large quills remain attached to the wing and separated from the body.

To assist the preservation and increase the durability of these wings some falconers cut

open the skin on the inner side of each wing over the two bones called the *focilia* [the radius and ulna], remove the flesh between them and fill the space with ashes—as a precaution against worms. Other falconers prefer a different treatment; they hang the wings in the smoke (of the chimney) until all moisture has evaporated from the fleshy parts. However, those wings that have not been smoked are always brighter and more beautiful than, although not so durable as, the smoked variety. The reason is that the flesh has been removed and the tendons cut, so that the bones are less firmly held together. This is true also of other types of the lure.

Two crane's wings are sufficient for the construction of a lure. In making the lure the wings are fastened together in the following manner: The two bones of one wing (from which the flesh has been removed) are placed in juxtaposition with the corresponding bones of the second wing. They should touch in such a manner that the lower portions of the wings hang down and the upper parts are above, that is, they maintain the same position they held when attached to the body of the bird and folded against the back.

While the two wings are thus held close together, take a thong of deerskin or other leather two and one-half feet long and the width of the thumb, one end of which is cut into two equal strips a foot long, making two end-pieces at one extremity of the larger strap. These thongs should be inserted one in each wing. But before this is done they must be tied together to prevent the cut between them from becoming enlarged or their being torn apart. In each case the insertion of the thong should be made in that part of the wing that is in close apposition to the other, that is, near the second joint. The end of the thong should be inserted from the upper [outer] side and drawn out at the lower [inner] side. The perforations made by the introduction of the thongs should be placed

between the bones mentioned. When the ligatures have been drawn all the way through, they should be knotted together as firmly and tightly as possible on the lower [inner] side of the wings and the two ends left beneath the wings.

Next the two extremities of a second thong, a foot long, should be inserted from below, one in each wing in the same hole (or in holes very close by) and half the ligature drawn through each wing. This thong should be tied as tightly as possible, so that it may not become unfastened or even loosened. A second and similar ligature should be made at the other side of the first incision, near the end of the first joint. These last two straps should be made a foot long, so that after the two wings have been firmly tied together there will remain on the upper side of the lure the ends of these two ligatures, and on the under side the two ends of the first ligature, all of the same length.

Although these two fastenings may be enough to bind the parts firmly together, a third one, similar in all respects, should be placed between the other two, the ends of which will serve, along with those of the others on top and below, to tie meat to both sides of the lure. When so arranged, it matters not which side strikes the ground; the gerfalcon, enticed by it, will find meat on the exposed side. This is especially necessary in the case of falcons that are not fully trained, and especially if they are branchers. Were there no meat on the upper side of the lure when a gerfalcon alights upon it, her attention would neither be attracted by nor fixed upon the food and she would be less likely to await the falconer's arrival but would abandon the lure and fly off.

A round wooden ball, the size of a walnut¹ in its outer green husk, should be fastened by some convenient method to the long strap by

¹ *nux regalis*, i.e., *Juglans regia*, or European walnut.

which the lure is suspended, at a distance of about half a foot from the lure. This ball, as a support for that contrivance, is inserted under the falconer's belt on the right-hand side so that the attached lure may hang there and readily be carried about.

At the upper extremity of the long strap a slit should be made through which the falconer's fingers may pass when he swings the lure.

CHAPTER II

ON VARIOUS CLASSES OF FALCONERS WHO, REPREHENSIBLY, DO NOT USE A LURE

In our day there are people in a number of countries who do not use a lure such as we have described to recall their falcons, but employ live fowls, as in Spain and Western territories near by. In Arabia and certain other Southern and Eastern lands live pigeons are used. But we condemn both these practices, for the reason that live birds are not always easily procured, as are bird's wings. Moreover, captive birds always try to escape and many pigeons and chickens are lost while being transported from place to place. When this occurs the falconer is unable to fly his falcons, since he has no means of recalling them.

There is the further objection to live lures that there are domesticated hens and pigeons that live in the vicinity of houses and farms. When a falcon is cast off to fly at quarry she may see some fowl or pigeon upon which she is accustomed to feed. She will then abandon her pursuit of the bird at which she is being flown by her falconer and will make off after the fowl or pigeon. The consequence is that the falcon learns to frequent farms, and the peasants and farmers who own the pigeons and hens kill the falcon, because of her depredations, while she is standing on her prey.

Sometimes, also, pigs, dogs, and other domestic animals attack her. An additional disadvantage is that hens are often hosts to lice and a falcon that is allowed to feed upon barnyard animals soon becomes infested with these insects.

When a wild falcon is called to the lure and is made familiar with that device, it is with the intention of making her forget her wild ways and return of her free will to the falconer. But when she is recalled with a pigeon it is a fresh reminder of her wild state; and when a falcon is fed on pigeon each time she is flown and she sees one—either domestic or wild (for they are often found in the fields)—she may chase the pigeon (or any similar bird), and in consequence the falconer's purpose is defeated. What was intended as a means of recalling the falcon has become a cause of her further wandering and of her consequent and permanent loss, because more falcons go astray in following improper quarry than for any other reason.

The following is another evil result of recalling the falcon by means of a live pigeon. When the gerfalcon is flown at cranes, bustards, geese, herons, or any other large species, she may or may not pursue them. And if she does not, she must be recalled at once, using the agency to which she is accustomed, that is, a hen or pigeon. When she is flown upon another occasion the same inducement will have to be used to recall her once more. Having flown badly the first time, she will fly even more reluctantly a second time, since she hopes to be recalled again with a pigeon or hen. Should she, however, fly after the large bird at which she has been slipped, it may happen (and it often does) that she will attack and struggle with it but be unable to hold it because her quarry now is not a weak pigeon but a larger and stronger prey. For this reason, or through its cleverness, or else because no one has come to the falcon's assistance, it

escapes. After the quarry has fled the falcon must at once be recalled with the usual fowl or pigeon. But when she returns to the pigeon after she has been buffeted and, perhaps, seriously injured, she may or may not feed upon it. If she does not partake of food now she will have no sense of being rewarded, and when she is flown again, at a crane for example, she will not only fly less eagerly (remembering her wounds and distress) but will not return willingly when called because she received no recompense on the previous occasion. Again, if she is fed on a live lure, the next time she is flown at a crane she will be even more unwilling to attack, having in mind the ills she suffered from this formidable prey and the good meal she obtained by taking, with no effort, the fowl or pigeon, both weak birds. She will believe that she has been rewarded not for the battle she has lost but for her success with a weak foe whom she overcame without effort. As a result she will be more and more inclined to return to the feeble quarry that she found an easy captive rather than to fly after a strong opponent that did her serious harm. Moreover, the chicken and pigeon have no resemblance to a crane, and small birds are always the first choice with untrained birds of prey, since they can be caught without risk. Therefore the falcon is more willing to return to her master than to attack a crane.

Another objection to this form of lure is that a falcon trained to return by means of a pigeon, hen, or other live bird might refuse such quarry and be unwilling to return when summoned with it. When this happens there remains no other certain means of recalling her. The artificial lure would be useless, as she has not become familiar with it. On the other hand, when a falcon that has been trained with the lure refuses to approach when summoned, a live bird may be thrown to her. Her pleasure in capturing a living quarry will render her more eager to ap-

proach. This treatment sometimes makes her unwilling in future to return to the lure, yet how much less willing to come to the lure of crane's wings must be those falcons that have not been trained with it and do not recognize it.

We repeat: the pinion lure and similar mechanical appliances are of no use for the falcon that has been trained with live birds but refuses to come when recalled with them; but a living bird is often quite effective in recalling a falcon that has been trained to return when summoned with the lure.

CHAPTER III

ON THE METHOD OF LURING WITH A LIVE BIRD

Although we have just said that it is not good practice to train a falcon to return to a live hen and have given our reasons for this belief, nevertheless we shall describe the method some people use in teaching a falcon to return when recalled in that manner. We do this that we may know what the method is and then leave the topic and discuss our own preference.

He who lures his falcon with a live bird does it in the following manner: Before training her out of doors to return when called, the falconer provides that as soon as she has been unseeled and tamed indoors, a pigeon or a hen is killed. He then feeds her two or three times on his hand from the pigeon or hen (whichever is to be used to recall her out of doors). This is done to establish her desire for this kind of food.

As soon as the eyas' flesh has diminished and she is sufficiently reduced to be entered to quarry, carry her, with a live pigeon, outdoors to a field. Tie a line to her leash and unwind it on the ground in front of her. Then release the pigeon a short distance from

the falcon. If the quarry is a strong flyer, a few of its flight feathers should be removed lest it escape. Then the falcon, with the line attached, is allowed to fly in pursuit and to kill the pigeon, while the falconer gives her the usual vocal encouragement; and this plan should be followed for the next two or three days whenever she is to be fed.

The next step is to release the pigeon at a little greater distance, and finally at the full length of the line. When the falcon has learned to fly to the pigeon boldly and her instructor thinks she is to be trusted, the cord is removed from the bird's leash and tied to the pigeon. The latter is now swung in the air in front of the falcon in the same manner as with the other lure. In this operation the line should be attached to some part of the pigeon other than the leg, because that limb is easily severed from the body during the struggle that ensues when the falcon seizes the pigeon and tries to carry it off.

A hen is employed in the same fashion, but she is never tied with a line, as she is heavy and the falcon is unable to "carry" her. But the pigeon should never be without the cord, tied preferably to one of its wings. When releasing the quarry one man should hold it along with the cord and a second assistant should carry the falcon on his fist. The man with the pigeon should walk away to the distance he thinks the falcon will follow her prey. Let him hold the cord a short distance from the pigeon and twirl it about, showing it to the falcon, at the same time giving the familiar call note used when the pigeon was placed before her so that, hearing the signal, she may return, seeking food. As soon as the assistant sees her approach he should throw out the pigeon in front of her, but some little distance away. She should then be permitted to kill and feed upon it. Falconers who use a hen proceed in the same manner, except in such particulars as we have indicated.

¹ A falconer's term meaning "to fly away with."

It should be noted that a falcon is never to be carried out of doors without a leash until she is made to the lure. If this precaution were not taken, she might pull the jesses free from the falconer's grasp and escape. This accident sometimes occurs because of the too rapid gait or stumbling of the falconer's horse, or because the falcon's bating is unexpectedly strong in her (wild) effort to elude the bearer.

CHAPTER IV

THE EMPEROR'S METHOD OF LURING

We ourselves use the following method of luring. Before the falcon has been thoroughly manned, indoors and out, by the method we have described, we reduce her meat ration in the regular manner so that she will be fairly eager for food. Then we tie meat to the lure by means of the leather thongs before mentioned. That she may be quickly attracted to the lure, the meat chosen is what we have observed the falcon to enjoy most. As we have mentioned, this food should be fastened to both sides of the lure so that no matter upon which side that device falls to the ground there is meat in evidence; should the lure roll over, the falcon will always discover meat upon the exposed side. The tit-bits on the lure should consist of the neck and some ribs of a chicken or other bird, or the sacral¹ bone with the rest of the back. With these, or similar parts, she may be enticed and fed, resting on the lure until she is lifted off and given a meal in the manner indicated. Or else the falconer may at once, if he so desires, summon her again with the same lure and ration of which she has consumed only a little.

The falconer should be assisted in all this by an attendant, whose duties are to hand him

¹ Bologna MS., fol. 72^v, col. 1, *ossa acharum cum residuo dorsi*; Valencia Codex, fol. 118^v, *ossa anchorum*.

the lure, bring him the meat with which to feed the bird, call the falcon to the lure, and other tasks that will be described in their proper place.

Let us repeat that first of all the falcon must be introduced to the lure and fed standing upon it (to the accompaniment of the proper vocal sounds used in luring) both indoors and in the courtyard. This must be done for two or three days—twice a day in summer (in the morning and at dusk), and once in winter, in the morning only. In this way she will become fond of the lure and recognize it later when she is called to it in the open fields. Unless she has become familiar with the lure indoors, when she is carried outside to be trained with it the falcon (coming into the open) will be so elated at seeing the blue sky and the birds flying about that she will take no notice of the lure. Therefore, to prevent her making off the minute she is released to fly to the lure she must be secured in some manner lest she escape. A gerfalcon, were she flown unattached at the start, feeling herself free, might upon leaving the fist make off and, if she saw a bird she liked, abandon the lure for this new prey. If she is not yet familiar with the lure it would then be impossible to recall her. It must also be remembered that some terrifying object may intervene to frighten and drive her away.

CHAPTER V

ON THE USE OF THE CREANCE IN LURING

The best means for securing the falcon is a slender cord of suitable length. While its chief value is to prevent the bird from flying away during her first flights from the fist, it must be long enough to permit her to reach the lure. The lighter and more flexible this line, the more suited will it be for these pur-

poses; yet its lightness and fineness should be determined by the size and strength of the falcon, who must not be able to break it. A length of twenty paces¹ is sufficient. This cord is called the line (*fileria*), or by some a creance (*credentia*).² The latter term is used because in her first flights from the falconer's hand and in her initial trips to the lure (while she is being taught not to fly away from her master) she is not allowed to fly free but is "entrusted" to the line,³ lest in her lean and wild condition she prefer the freedom of the skies to settling on the lure.

When the falconer wishes the falcon to perch upon the lure, either in the mews or in the courtyard, he must tie one extremity of the line to the end of her leash. The falcon should be carried with the attached leash not only during her initial training but until her education with the lure is completed. Were she borne without a leash, while still inclined to be unruly, the stumbling of the horse or her own vigorous bating (caused by the sight of some unfamiliar object) in an effort to escape, might jerk the jesses from the falconer's hand, leaving her free to fly away. Later, however, when she has been trained to return to the lure, she may be held and carried about with jesses only and without the leash.

After this line has been attached to the end of the leash, and as much of it unwound as is necessary for the ascent or other flight of the falcon, the bird should be taken on whichever hand the falconer prefers and the lure handed to him by his assistant, who should approach him on the side opposite the hand on which he is holding the falcon; e.g., if she is on the right fist, the associate must come from the left and pass the lure with the hand nearest the falconer. In the meantime the latter should remove the hood, if the bird is wearing one. Then, taking the lure (with

¹ *XX paxium. Passus*, "five Roman feet."

² From *credere*, "to trust."

³ *sed creditur illi filerie que credentia dici potest.*

meat attached) in his free hand and showing it to the falcon, he should bring it close to her, tempting her to bite. At this time he must make the call notes she is accustomed to hear when feeding and that he intends to use in luring. Whenever she hears this call she will understand that she is being called to the lure. While she is biting the meat offered her, the falconer must keep firm hold of the jesses lest she seize the lure or its provender with her powerful talons; for it would tire and discourage the falcon if it were necessary to pry loose her foot from the lure. The falconer should now pass the lure to the assistant, who must receive it in the hand with which he passed it to the falconer. Then with outstretched arm the assistant must retire in such a way that the falcon does not lose sight of the lure and its meat. The assistant should also carry in his purse additional meat upon which (later) to feed the falcon.

The next step is to place the lure on the ground at such a distance as it is hoped the falcon will fly to it. If that distance is found to be too great, it should be sufficiently reduced.

The person holding the lure should show it to the falcon, while making the usual sounds. As soon as he sees the falcon leave the fist, he must put down the lure and retire at once. If, however, he notices that the bird while fixing her gaze on the lure does so with no eagerness and (through fear) does not move, he must not place the lure on the ground. Finally, when the falconer sees that his bird is gazing intently at the lure, he should release her in such a manner that the line will run through his free hand, as well as through that on which he has been carrying the falcon. Thus the cord passes smoothly (with no hindrance to the falcon's flight) through both upraised hands, unimpeded by any obstacle on the ground.

As soon as he sees the falcon coming, the assistant who has set down the lure should

retreat quietly, turning about so that the bird does not see his face. The falcon must not be urged to fly any great distance upon her first trial, so long as she comes to the lure and feeds upon it. It should be our purpose on this occasion not to have her make a long flight but to have her recognize the lure and be attracted to it by the meat on it. Afterward, owing to this favorable experience, she will come a longer distance to the lure.

CHAPTER VI

OF HOW TO APPROACH A FALCON STANDING ON THE LURE

The assistant, having retired a short distance, should not again approach the lure until the falcon has alighted on it. When he sees that she has gained confidence and is intent upon her repast, he may approach her, but in the following manner: Keeping his broad-brimmed hat on his head so that the falcon will see less of his face (for she may be terror-stricken by the sight of a man's face), let him walk gently and very slowly toward her, circling her at such a distance as not to frighten her by this maneuver. If she should interrupt her meal because of his approach, let him desist until the falcon resumes her repast and then approach in decreasing circles, gradually drawing closer to the falcon but always turning his head so that his face is as far as possible from hers. As he encircles the bird in this way, he should have in his hand meat that he constantly holds out to her, repeating at the same time the sounds used in training and feeding her. These acts will draw her attention to himself and prevent her from leaving the lure. He should move always in such a way that the hand holding the meat (on which he intends to take her up) is continually extended in her direction. This encircling movement may be begun at a longer or shorter distance from the falcon and should

be governed by the degree of tameness she has attained. For a falcon still wild the assistant should begin his approach at a distance by making quite wide circles; but he may start closer to a tamer bird. In any event, he should move in an ever contracting spiral while the falcon becomes accustomed to his presence.¹ The falconer should make his last turn so near the falcon that, when bending down and reaching out his hand with it, the meat will be directly in front of her. When this point is reached he should take a last step toward the falcon with the foot corresponding to the hand carrying the meat, doing this so gently that she will not be frightened. He must now bend over, stretching out his hand with the meat and at the same time flexing the opposite knee and lowering his hand to her feet to give her a better view of the food. She will have less fear of his hand when it appears below her than if it comes from above.

CHAPTER VII

ON FEEDING A FALCON ON THE LURE; AND ON HOW TO LIFT HER FROM IT FOR REPEATED PRACTICE FLIGHTS

The falcon prefers the meat thus directly offered her to that on the lure for the reason, perhaps, that the latter has become soiled by coming in contact with the earth when the lure rolled over, either as it struck the earth or while the falcon was tearing at it; or else the food is of better quality and flavor than that on the lure. When she has seized the meat held in the falconer's hand, it is easy to take her up.

Where the falcon flies well to the lure, and while she is standing upon it (as it lies upon the ground),² let the falconer give her a complete meal of the meat he is carrying (that is,

if he wishes to feed her). This should be done in the following manner: If the food is the leg of a chicken or other bird, let him place it on the lure and slip his hand back so that he holds it only by the foot. If it is a wing, he should hold it by the tip and allow the falcon perched on the lure to have the whole wing. If the meat is of another sort, tie it in some manner that it may be given to the falcon, yet held securely. By this procedure the falcon becomes better acquainted with the lure, for she is fed standing upon it and not on the fist. The falconer must keep the hand that holds the meat as much as possible away from the lure. Although the falcon is prevented from flying off with the meat, her attention is fixed upon the lure rather than upon the falconer's hand.

If it is discovered that the falcon does not fly well to the lure, it is best to repeat the lessons aforementioned, to secure either a better or a longer flight. To do this the falcon must be taken up in the following manner: After the falconer has placed his hand holding the meat on the lure and the falcon has grasped the provender and is contentedly feeding upon it, he should grasp the lure in his free hand and with both hands lift both the lure and the falcon and rest them upon his knee. This method is followed because, if the falcon is hungry and the falconer tries to lift her from the lure as it rests upon the ground, she might in her struggle for food strike her tail and wings against the earth and injure her feathers. This is unlikely to happen if she is lifted with the lure onto his knee.

After the falcon has been brought to that position the falconer must observe whether she is grasping the hand that holds the meat with one or both feet or with neither. If she has hold of his fist with both feet, the falconer should gather up the jesses and draw them tight so that she cannot again grasp the lure. The falconer must then remove the lure—an easy task, performed with his free hand—and

¹ *assecuret se bene de ipso.*

² *illo loco.*



PLATE 99.—Reichsfalkenhof, of the German Falkenorden (photo by Fischer)

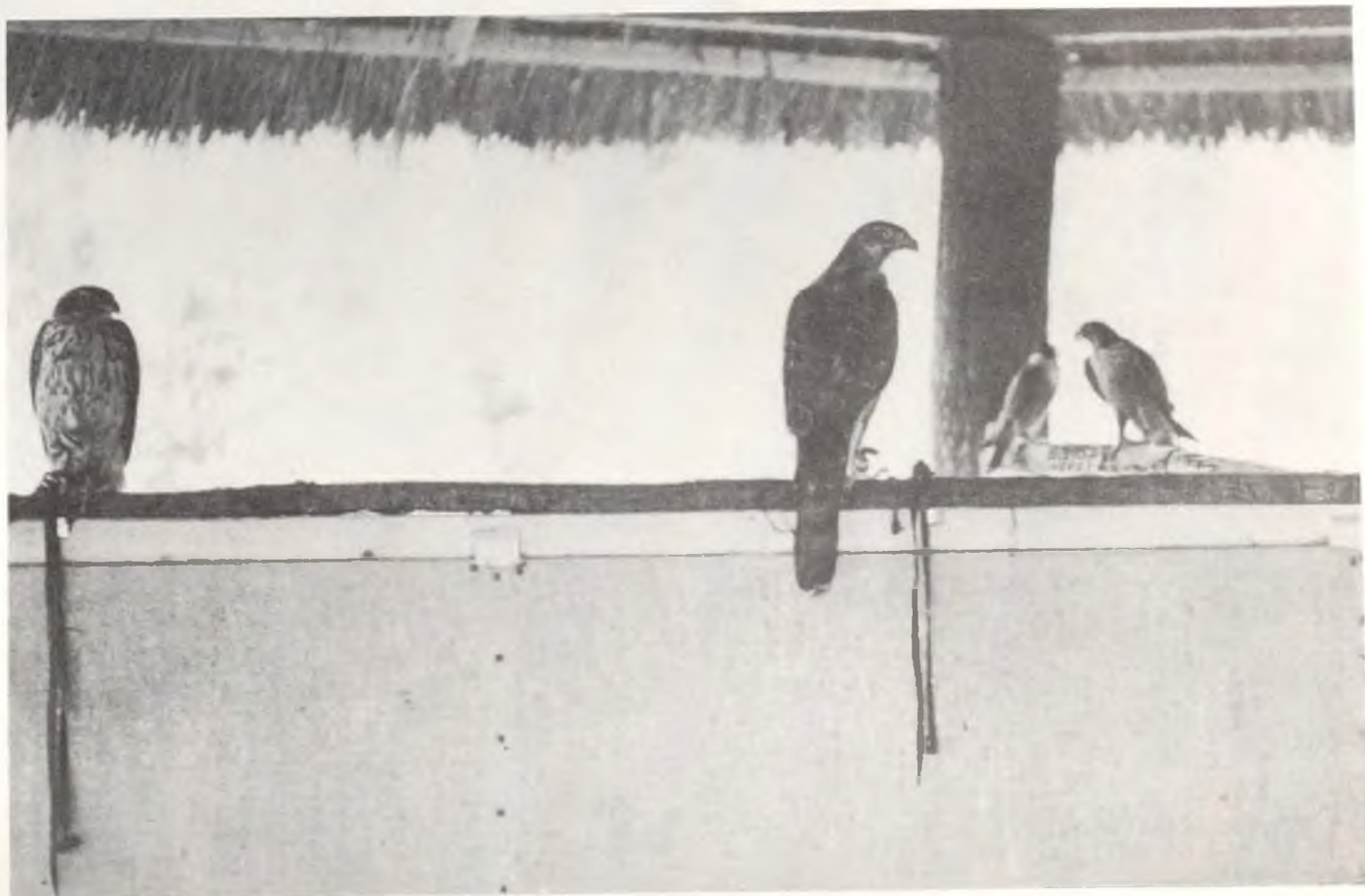

PLATE 100.—Outdoor shelter for falcons and other hunting-birds in the Reichsfalkenhof, Germany (photo by Fischer)



PLATE 101.—“Mushroom” refuge for hunting-birds in the Reichsfalkenhof, Germany (photo by Fischer)



PLATE 102.—*Falco Peregrinus anatum*, "Lady" (photograph by Arthur Van)

lay it aside so that she will not see it, or she may jump from his hand (that is holding the meat) and pounce upon it. If she holds the falconer's hand with one foot only, he should gently pry loose from the lure the claws of her other foot and place that foot on his fist beside the first, gathering together the jesses so that she may not again grasp the lure, which is now removed and hidden, as in the former instance. If she has neither foot upon his hand, he should first lift the falcon's foot that is nearer him to his fist and at once grasp its jess, then raise the other foot and gather its jess into his hand and, as before, withdraw and hide the lure. Having in this manner been lifted to his fist, the falcon is ready once more to fly at the lure and be fed while standing upon it.

At the beginning of the falcon's training with the lure, the assistant who carries the latter should always retreat, holding it in his outstretched hand and showing it to the falcon. This must be done until the time arrives when she bates toward him even though she cannot see the decoy—a sign that, in luring her, it is no longer necessary to keep the lure continually in her line of vision.

CHAPTER VIII

ON THE CHOICE OF A LOCALITY FOR THE FIRST OUTDOOR TRIALS WITH THE LURE

When it is desired to lure the falcon out of doors for the first time, one generally has a choice of plowed land, sandy areas, roads, or meadows. On plowed land the creance may be impeded, as it unwinds, by lumps of earth. Also the lure may become soiled by earth that has been stirred up by the plow; and when the falcon feeds on the lure she may injure her wings and tail on the hard, earthen clods.

On sandy soil there is no danger of injury to wings and tail feathers, nor is there any

impediment to the smooth running of the retaining cord; but the meat on the lure may become soiled and the falcon be badly nourished if she eats it, or she may shun the unclean meat altogether. Pollution by sand is, however, less harmful than that by plowed earth.

Upon a road the movement of the creance is not checked nor are the falcon's feathers injured (by contact with obstructions), but the meat may easily become soiled if the roadway is dusty. The passage of men and animals on a highway is also a hindrance to the use of the lure; but if a wind blows along the road it is usually beneficial.

A meadow is by far the best locality for outdoor luring, as there is there no obstruction of the line, the falcon's feathers do not suffer harm, and the meat on the lure remains unsoiled. The shorter and thicker the meadow grass, the better the situation for our purpose.

When first the lure is used out of doors, i.e., while the creance is still employed, one should avoid localities where the grass is long; for the falcon's view of the lure and its meat is obscured thereby and she is not tempted to fly to it or, if she does perceive and go to the lure, the attached line may be caught and held at some point by grass stalks, causing her to fall in the herbage. Even if she is not much displeased by this accident, it becomes difficult to gain access to and recover her.

Luring must never be practiced on grass that is wet with dew. One should wait until the dew has dried off. For a falcon who sees dew-sprinkled grass will think there is water beneath it and may not come down at all. If she does, she is restrained by the creance and will of necessity be forced down into the moist herbage and be more frightened than if she fell into dry grass. For the dew doubles her difficulties. Hence one should never practice with a lure in long grass and much less in dewy meadows.

Planted areas are also bad places in which to practice with the lure as, when drawn out, the line easily becomes entangled in the vegetation. Nor should one choose localities where there are high trees. Falcons like open ground and hate trees, where there may be enemy eagles, vultures, and other birds whose presence man is not so quick to detect as are they.

CHAPTER IX

OF THE WEATHER AND HOURS SUITABLE FOR LURING; AND OF FURTHER PARTICULARS CONCERNING THE USE OF THE LURE

It must again be noted that in summer a falcon may be exercised with the lure twice a day, i.e., in the morning after the sun has risen fifteen degrees above the eastern horizon, in other words, in the early hours of daylight;¹ and again in the evening, when the sun is fifteen degrees above the western horizon, in the last hours of the day. One must take into consideration whether the day is fine and warm, or rainy. In the former case, the first hour may be somewhat advanced and the evening hour retarded. If the weather is cloudy and cool, the morning exercise may be a little later and the evening practice somewhat earlier.

It should be remembered that practice with the lure should be made to correspond with the customary mealtimes of the hawks. They feed twice a day in summer and may, therefore, be called twice to the lure. In winter they are fed but once; hence they should be lured once only and at the same hour.

At least two men are needed for practice with the lure out of doors, one to hold the falcon and a second to call her to the lure. They both should be on foot and the exercises carried on in a meadow wherever one is available, otherwise in the next most conveni-

¹ *hoc est in prima hora vel tercia.*

ent and desirable of those localities we have just described. The assistant falconer who is not holding the falcon should draw out the creance, while the falconer who carries her on his fist should retain in his other hand the ball of cord, allowing it to run loose. The assistant must walk as directly as possible into the wind carrying the free end of the line (creance) to a distance such that he thinks the falcon will be willing to fly to the lure. At that point he should place a mark indicating the length of line to be unwound for the purpose of luring. Putting down the end of the cord at this point and returning to the other extremity, he must draw in the line and let it fall in coils on the ground in such a way that the second coil rests on the first and so on until the end that was first drawn out lies on top near the carrier of the falcon. The falconer should stand in such a position that the coils of the creance are on the side away from the falcon, while his assistant is on the same side as the line. The latter should now fasten the meat to both sides of the lure, as has been explained; and, since he has both hands free, he is the one who must also fasten the upper extremity of the creance to the end of the falcon's leash. He now begins the exercise by holding out the decoy to the falconer in the manner previously indicated. The falconer in the meantime must remove the falcon's hood, if she is wearing one; if not, he should interpose his body between the falcon and the lure. He now takes the lure from his assistant and permits the bird to nibble morsels from it, as we have explained, and then returns it to the assistant. The latter now carries it straight to windward to the spot marked on the ground or to some point close by, and moves the lure about close to the ground so that the falcon will notice it and the meat on it.

As the assistant walks away from the falconer he must not turn his face toward the falcon but must keep his back to her; and in

showing her the lure he must not frighten her by looking directly at her, as she has a greater natural fear of his face than of his back. Also, when retreating from the lure as he sees her coming, he should do so in a wide circle and as rapidly as possible without frightening her by his movements, causing her to turn away from the lure. The falconer, as he holds the falcon, should observe her closely and, when he sees that she is looking intently at the lure and is eager to fly to it, he should set her free. But if she is staring at something else, yet bating in the direction of the lure, as if she saw something beyond it that she would like to seize, she should not be allowed to fly free until her gaze has been brought back to and fastened intently upon the lure. As soon as he sees the falcon coming, the assistant holding the lure should place it on the ground, but not so far from her that she will lose sight of it nor so close to her that she will be frightened by the movements of his withdrawal.

A falcon must not be lured when the wind blows across her path, for when she makes a turn to alight against the wind (as birds do whenever they come to rest) the circling movement may drag the creance over the surface of the earth and as it trails along it may catch upon some obstacle in its path (for it is almost impossible to find an area so clear and smooth that there are no obstructions), with the result that the falcon is pulled backward as she turns to alight. Such an obstruction with its consequent tug on the line will force her to the ground before she reaches the lure. As one result of such an accident the luring exercise is repeated at a time when she is less eager to come to the lure because of the fright she has received.

Therefore, if one lures a falcon from a distance in a cross wind, or with the wind at her back, obliging her to make a turn of half a circle or more, in order to alight on the lure facing into the wind, the creance must be of greater length than the diameter of the circle

or she will be unable to complete her turn. She will be jerked back and will fall to earth, as the cord is too short to permit the turn to be completed.

Luring in a cross wind is bad practice, but it is much worse to lure a falcon with the wind (i.e., blowing against her back) as she goes toward the lure. For, since she must take off headed into the wind, she is uncertain of the position of the lure (that lies down wind) and must make two turns before coming to rest upon the lure, one after taking off from the fist into the wind and the second after she has flown beyond the lure in order to come back and alight upon it while facing the wind. Also, on making the second turn she may be frightened by the face of the assistant, who has previously been standing with his back toward her. For these reasons a falcon should not be lured either in a following or in a cross wind. In windy weather the only alternative is to call her up wind. The line will not then become entangled as the falcon circles, for no turn will be necessary. The wind comes from straight ahead, and with its aid she is in a favorable position to descend and go to perch.

CHAPTER X

OF FINAL INSTRUCTIONS FOR PRACTICE WITH THE LURE, BEFORE THE FALCON IS RELEASED FROM THE CREANCE

When it is found that the falcon attached to the creance comes well to the lure and is at ease standing upon it, she must, before the line is removed, be called not only to a lure placed on the ground but also for several days to one thrown out to the accompaniment of recall cries. She will thus not only grow accustomed to these calls and understand them but also become used to the throwing of the lure. Whenever she is lured it must be done with the same hand, i.e., that used in begin-

ning the instruction, in showing the lure to the falcon, in putting it down, and in tossing it out. If the lure be transferred from one hand to the other, some falcons might not understand the meaning of the movement and try to fly at once to the lure.¹

It is of prime importance to familiarize the falcon with the tossing of the lure. If she is not familiar with its projection while she is still attached to the line and while the falconer is on foot, then later, when she is lured on horseback without a line and the falconer astride his horse cannot place the lure on the ground and is obliged to throw it from him, she will disregard the lure and hold fast to the fist, since she has never before seen this maneuver. Also, if the assistant wishes to dismount and place the lure on the ground, he must ride ahead before dismounting to lay down the lure.

For these reasons, before a falcon is lured without a line and while the falconer is still on foot, she must grow familiar with the recall cry and the throwing of the lure. Then she will more readily recognize the decoy when thrown by a horseman.

There are, then, three steps involved in calling the falcon to the lure: First, the whirling of the lure; second, the use of the voice; and, third, the tossing of the lure. When a hunting bird flies away it is mainly by these means that she is recovered.

Let us repeat that when it is seen that the falcon has grown confident and flies well to the lure, and before the line is removed, the lure must be thrown out to her at about the distance to which she has been accustomed to fly when it was placed upon the ground, i.e., not so close as to frighten her nor too far away for her to see it. When the falconer has swung the lure a few times as rapidly as re-

quired, he should let it fly, not raising it too high, but casting it out laterally for about four paces. If it is tossed farther it may interfere with the creance as the falcon draws near and turns from the direct line of her flight toward the falconer in order to go to the lure. This obstruction of the line, or its failure to reach as far as the lure, may cause injury to the falcon. The lure must be thrown low so that it will revolve as it strikes the ground, thus further attracting the falcon toward it. If it is thrown high it will not roll over as it comes to earth and will not be so likely to attract her attention.

The lure should not be thrown in the path of the falcon, i.e., toward her as she draws near, because she is always frightened by the direct approach of an object; but it should be cast before her line of flight. She will then fly after it. Tossing the lure directly in front and away from the falcon is the worst possible procedure, as the assistant then stands between the approaching falcon and the lure and as she passes him she may be frightened by his presence and, turning aside, fail to reach her goal.

There are many falcons who, when flown to the lure, do not settle upon it but land near by, look about timidly until they feel safe, and then walk to the lure, upon which they perch. Should a falconer approach such a falcon, she will try to "carry" the lure; if she is unable to do this, she will drag it along the ground; if this fails, she will drop it. All this is the result of her wild condition; and she may even be lost if she has been released from the line. Such birds and, indeed, all others should not have the creance removed until they give proof of their fitness for freedom, chiefly by the following signs: As soon as a falcon on the fist sees an assistant starting out with the lure, she begins to bate toward him, and when she sees the lure she immediately springs from the hand and, without delay, flies eagerly toward the decoy and

¹ Bologna MS., fol. 75^v, col. 2, *quod ex secunda transmutatione ignorent quid eis fieret et ad loyrum vellet venire*; Mazarine Codex, p. 304, . . . *quid ei fieret et ad loyrum nolet venire.*

settles greedily upon it. There she awaits quietly the coming of the falconer and does not drop the lure when he arrives. When these indications of the falcon's tameness are in evidence, her training without the creance may safely begin.

CHAPTER XI

OF LURING THE FALCON ON FOOT WITHOUT THE CREANCE

Before a falcon can be lured on horseback, she should be called to the lure on foot and without the creance, at no great distance, at least not too great.¹ On the first occasion the distance should be about twice the length of the line (previously used), and it may be increased gradually to a hundred geometrical paces, a pace being equal to three arm-lengths (as measured on an average man from the elbow to the tips of the fingers).²

To lure the falcon on foot and without a creance, one proceeds as follows: At first the assistant who has the lure should carry it to the point at which it is to be thrown. There he must show it to the falcon, as he did when she was secured by the creance. He must now swing the lure, held by a long leather strap. When the falcon arrives at the place where she has been used to have the lure thrown to her, he must toss it low near the ground and as far away as possible. But if the assistant notices that the falcon starts to turn away before the lure has left his hand because of its unusual whirling motion, he should at once toss it to her. She will now recognize the familiar tossing motion.

¹ *non longe, non longius.*

² Bologna MS., fol. 76, col. 2, *Brachium dicitur a principio meri usque ad extremitatem digitorum.* Mazarine MS., p. 304, supplies for *meri, humeri.* The geometrical, or great pace, is five feet. The Roman *passus* was measured from the heel of one foot to the heel of the same foot when it next touched the ground, or five Roman feet. The *brachium* was, in particular, the forearm, from the hand to the elbow—more generally the whole arm.

If the falcon does not see the lure the first time, it must be picked up and thrown again. This method of luring should be repeated for several days until she grows familiar with the whirling motion of the lure. In case the falcon exhibits no desire to reach the lure that is thrown to her, but flies away, the falconer (who was holding her) should have in reserve a second lure and a horse near by but not so close to the first lure that she will fly off through fear of the horse. He must follow the falcon on horseback, and when he has reached a place where she can see him he must throw out the lure without whirling it. Whether the falconer is on foot or on horseback, this last operation should always be performed in the same manner. He must thus follow the falcon, calling her continually, until he reaches her, and then proceed as we have indicated.

CHAPTER XII

ON LURING THE FALCON ON HORSEBACK, AND ON CERTAIN PRECAUTIONS TO BE OBSERVED

When it is found that the falcon leaves the fist to fly to the lure as soon as the assistant reaches his post and starts to whirl the lure, then we know that she is ready to be lured by a man on horseback who will swing the lure and call out in the same manner as was done formerly on foot and without the creance. As we have said, it is not easy when on horseback for the falconer properly to lure a falcon attached to a line.

When all these training stages have been completed, the falcon may be lured on horseback for greater and greater distances, just as was done on foot. Whether one uses the right or the left hand to swing the lure, one should always take up a position such that neither the horse nor one's body is brought between the lure and the falcon, as her view of the lure might then be interrupted. The lure should

be swung several times rapidly, then a call should be given; in this way the falcon is induced to come more eagerly. Were the assistant to call out before swinging the lure, the falcon might start but, not seeing her objective, wander off and be lost. It is therefore best to whirl the lure first and call her afterward. In this way she sees the decoy and goes at once in its direction. The maximum distance for luring on horseback is one stadium,¹ which is about a seventh of a *miliarium*. A *miliarium* is a thousand paces. The pace we have already defined in our chapter on luring on foot without a line.

If at first the falcon does not come to the lure when summoned by the falconer on horseback, he should not at once dismount and go directly toward her; for she may be frightened, as she is not yet familiar with either the horse or the horseman's movements in dismounting. He should carefully encircle the falcon in the same manner as on foot, always reducing his distance from her, and when she has gained confidence he should dismount gently and, continuing his circular path on foot, approach and take her up according to our previous instructions. Meanwhile (if these precautions are followed) she will wait while he encircles her until he takes her up on the fist on which she is usually carried. The falconer should dismount in such a way that the horse is not between himself and the bird, otherwise he would have to encircle the horse or turn his mount around in order to reach the falcon, which would be difficult and might alarm her.

The falconer (i.e., the man who has been carrying the falcon) should have with him a second lure in case the falcon is diverted by the sight of some bird (or for some reason does not see the lure) and flies away in an opposite direction. With this reserve lure he

¹ $\text{Stadium} = \frac{1000 \text{ paces}}{7} = \frac{5000}{7}$ feet, or over 700 feet; the Roman *stadium* was 625 feet.

can attempt to recall her. If the falconer had no second lure and allowed her to fly in the belief that she had seen the assistant luring her, the falcon, not having observed him, might fly about over the falconer's head or fly away altogether. When this happens the falconer on horseback should ride as fast as possible toward the assistant, at the same time calling out to the falcon, to induce her to follow him. As soon as he perceives that she has caught sight of the lure there is no further need for him to continue at such a pace.

This is the best method for luring falcons, in fact all species of falcons. It is sufficient for the training of any individual bird of prey, even of those caught for training after the first moult²—that are more difficult than others to tame and train to come to the lure.

To sum up: He who first lures a falcon should whirl the lure about several times before calling the bird. The falconer holding the falcon should watch her expression attentively and not permit her to fly until she has fixed her gaze intently upon the lure. If she bates toward the lure, but looks in another direction, she must not on that account be allowed to leave the hand. She bates of necessity toward the lure when she is being lured into the wind; hence she must not be cast off for that reason alone, but the falconer should wait, as we have explained, until she is staring eagerly at the lure.

Moreover, the falconer should be careful in luring the bird that the sound of his voice does not attract a dog. For it is the habit of dogs to come at the sound of a human voice. The presence of this animal may make her afraid to approach the lure, or if she has already reached it the advent of a running dog may terrify her, causing her to take flight and be lost, or may implant in her a dislike for the decoy.

After a falcon is thoroughly trained to the lure she no longer needs to be carried abroad

² That is, haggards.

when on horseback with a leash attached to her jesses. Should the horse slip and fall, the falcon tied to the hand is likely to be caught between the horse and the earth, or between the rider and the ground, or between the rider and the horse. The falcon may then be killed or at least seriously injured. Even if she escapes with the leash, it may catch somewhere and cause her to hang in such a manner that she is harmed before she can be rescued.

CHAPTER XIII

HOW FALCONS ARE LURED IN BRITAIN

Those who live in Britain and are called Anglians do not use the lure in the manner just described because they never lure on horseback, nor do they call out while luring. Instead they go afoot and toss the lure high in the air. They repeat this act until the falcon notices the lure and starts toward it. When the falconer sees her coming he stands still and allows her to alight on the lure. This is the reason they do not lure falcons on horseback, for it would be inconvenient and difficult to toss out the lure and then dismount to recover it in order to cast it out again.

We inquired why they do not call out, but they could only reply that it is their customary practice.¹ Nevertheless it is our opinion that their ancestors did not use a call in luring because, when falcons are flown at herons, it is necessary to call out because herons frequently take refuge on the water in fear of falcons and the shouts startle and make them rise more often into the air. Also when falcons are flown at cranes (at least when first entered and before they have taken many birds) it is necessary, after the falcon is cast off and before she approaches her quarry, to shout so that the cranes will be

induced to rise from the ground. If the falcon has become accustomed to being summoned to the lure with a shout, she will, upon hearing this outcry, think she is being called back to the lure and will leave the crane and return to the man giving the call in the hope of receiving meat on the lure. For these reasons they do not use a call in luring, since they hunt for cranes and herons more than for any other birds, but train their falcons in the manner described.

It is our opinion, however, that it is better to lure with a vocal summons, as it is natural for a falcon to fly from man. To wean a falcon from this normal instinct the use of extraordinary instruction and proper instruments is essential. Everything must be contrived to retain possession of a falcon once she is secured and to recover her if she is lost. Among suitable instruments are the lure and man's voice. The voice entices the falcon through the sense of hearing to follow the sound. As she comes close, she perceives the lure through her vision. But if the lure is whirled or cast upward (in the manner of the Angles) without calling, whenever the falcon cannot see the lure she will not come, for she will hear no voice guiding her in its direction. Remember that hills, cloudy weather, woods, and groves may all obscure the falcon's view of the lure.

Sometimes it happens that the falcon flies at and pursues a bird that her master has no desire to have her follow and at which she was not slipped. In that case, when the lure is whirled or thrown out with no accompanying sound, the falcon may not see the lure, as her eyes are fixed upon the bird, nor does she give up her pursuit of it to seek the lure; but if she hears the familiar voice of the falconer, she will turn her head toward him and see the lure. She will then abandon her pursuit of the quarry and come to the lure. For this reason it is best to lure with a vocal accompaniment that, by an appeal to the sense

¹ A sufficient British reason.

of hearing, brings about a visual perception of the lure. These two senses together awaken the sense of taste, through which she was first trained to come to the lure. It is thus easily shown (according to our opinion) that their [the Britons'] reasons for proceeding as they do are illogical. This we shall explain once more when we give instructions for flying falcons at cranes and herons.²

Where several falconers have gone out together and, having more than one falcon to lure, have reached a suitable locality, one of them should separate (with his lure) from the others so that the falcon that is to be thrown off may distinguish him from the rest of the group and be able to observe clearly the swinging of the lure. This would be impossible were he to choose a position too near the other falconers. It is also well for him to stand on high ground where no trees or other obstructions interrupt a view of the revolving lure. Finally, the two falconers (the first who releases the falcon as well as the second who calls her to the lure) must be experts in the methods we have unfolded.

CHAPTER XIV

ON FALCONS WHO REFUSE TO COME TO THE LURE

We have now explained all the measures necessary to complete the training of any kind of falcon by means of the lure; and they should suffice to secure perfect results. Yet there are birds that in spite of all this education are still not attracted by the lure. Indications of their dislike of it may be discerned while the falcon is still on the fist and before she is slipped to the lure. The symptoms of this defect (evident while she is still on the

² The last two sentences are a free translation of the rather obscure words: *Sed id quod diximus supra propter quod opinabamur quod ipsi facerent, facile docebitur emendari ut infra dicetur quando docebuntur volare ad grues et ayrones.* Bologna MS., fol. 77^r, col. 1.

hand) are identical in both hooded and unhooded birds. When she sees the assistant in the act of luring her, she will sometimes glance at the latter and sometimes look in another direction, to right or to left; or when she looks at the lure she will turn her head and neck toward it but on seeing it will not turn her body in that direction or flatten her feathers, although she may finally shake her feathers, mute, and fly toward the lure. Symptoms of dislike of the lure displayed after leaving the hand are these: She will glance back and gaze to either side; she will not fly straight to the lure, but wander here and there, and as she flies move her wings slowly. At times she floats on outspread wings and when she arrives at the lure she does not seize it eagerly. These indications of her lack of interest in the lure may all be more or less in evidence. Such a falcon must be exercised for a longer period with the lure than one who seeks it readily.

Everything should be done to make the lure attractive to the falcon in training, such as attaching to it special kinds of meat. Some falconers garnish it with a live pigeon or other bird of which she is particularly fond. We think this is not a bad practice.

When one is not sure whether or not a newly acquired falcon has been completely trained to the lure and likes it, she may be placed in training and her acts carefully observed to discover if she displays any of the adverse symptoms mentioned.

CHAPTER XV

ON THE CHARACTERISTICS OF PROPER FLIGHT; ALSO ON SIGNS OF INJURY OR FATIGUE IN FALCONS

When a gerfalcon is first flown to the lure one should watch her closely to see if she is sound in body and flying powers. To judge of her abilities and learn if she gives promise of becoming a strong flier, the falconer him-

self must understand the characteristics of good flight, especially since falcons fly to the lure in various fashions. Some flap their wings frequently and others at longer intervals; some have a strong wing beat and some a weak one. Of those fliers whose movements are slow, some are vigorous and others feeble. Again, rapid wing motion may be either powerful or weak. Certain falcons, when flying, raise their wings high over their backs, while others do not but bring them far down beneath their bodies. In either of these last two classes there are both weak and powerful fliers. Some falcons mount high and some fly low to the lure; others approach it at a moderate height. Among all these falcons there are those that never digress from a direct course because of the wind and others who are tossed hither and thither whenever they fly in a breeze. All these modes of flight may be observed in healthy falcons.

Unsound birds show their defects in sundry ways. There are some whose wings move evenly and powerfully yet possess a tail that droops, with its feathers partially separated, indicating weakness in the loins (*renes*). Those that have no such defect hold the tail correctly, i.e., flat and in line with the back. A defect in alation is shown when a falcon does not move her wings firmly but feebly and curved below the body, in which case she has a hump on the back above the tail. Such a bird, on reaching the lure, drops heavily upon it without control. When a falcon is defective in both wings and back she displays all the foregoing signs of distress.

There are falcons that exhibit uneven wing movements. One wing appears strong, the other weak; or one is extended and the other curved. If she has been injured it is sometimes the extended wing that is affected, and sometimes the curved one, depending upon the character of the traumatism.

We have described the modes of flying to

the lure found in both sound and unsound falcons and are of the opinion that the best type of flight is that in which the wing beats, while strong, are neither too fast nor too slow and where the wings are extended well over the back and are not brought too far below the body. In birds that display this kind of flight the back and tail form a uniform surface, i.e., the tail does not hang down. The best falcons fly to the lure neither too high in the air nor too close to the ground, but choose a middle course; and wind does not drive them from a straight passage. The feathers of the tail are held firmly together; and wing motion is smooth and regular. Those falcons that display these characteristics are of the most desirable type, but they are not numerous. One can safely say not only that by no means all falcons are of this sort but the best are they that have a powerful wing motion. Yet, as we have said, there are individuals of this class who do not like the lure and therefore do not show their best qualities when first flown to it. One should not despair of such birds but should ascertain whether their poor performance is not due to a temporary dislike of the lure rather than to some inherent weakness. In the latter case there is no hope of improving them.

Falcons that are worn out from bad methods of transportation, a long journey, or much bating, will give evidence of their fatigue when flying to the lure. They may really like the lure and be eager for it yet, because they are tired out, move their wings weakly, bringing them below the body (not lifting them high over the back); and they settle heavily upon the lure because they are exhausted from fatigue. The degree of fatigue will vary with the sort of maltreatment to which they have been subjected, the length of the journey, or the intensity of bating. It will depend also upon the normal strength of the species in question, as well as of the particular individual.

CHAPTER XVI

ON TESTING FALCONS TO BE FLOWN
IN A CAST¹

Now that we have explained the luring of falcons and shown what mode of flight offers the best promise of good results, let us, before we proceed to our next topic, the use of the train, consider flight in a cast. Some birds can be flown together and some cannot. Those falcons that fly instinctively in a cast can be more easily instructed with the train than those that do not; and it is found that there are fewer gerfalcons and sakers that fly well together than of any other species. These two species are most frequently taught to take large birds, in whose capture co-operation is more necessary than in hunting small birds.

As falcons cannot assist one another unless they are willing to fly in a cast, it is of primary importance that we early recognize the individuals among gerfalcons and sakers that give promise of working well together. Indeed, neither her acts nor her appearance may indicate a falcon's disposition to collaborate; because some birds will sit quietly together on the same perch yet cannot be flown in a cast and will not associate in other ways. On the other hand, falcons that will fly together do not always agree to remain on the same perch and to live harmoniously otherwise. They must be tested in action; and the best method of doing this is to fly them in unison to the lure. It will then be evident which of them will fly together and yet be unwilling to continue standing over their quarry, which will alight on the lure simultaneously and yet refuse to fly together, and which will do neither of these. Therefore it is best, even before they are flown to the train, to test them with the lure and so decide which falcons are likely to collaborate and in what manner; or, if they will not work in

¹ To fly in a cast is to co-operate in the taking of a single quarry.

harmony, to discover in what particular they are deficient in this respect. We repeat: such a test is useful in revealing not only what birds may be flown together but also the reasons why certain individuals cannot be used in this fashion.

There are three modes of behavior that disqualify a falcon for use with a companion. First, a falcon may seize the jesses of another. She does this because seeing them hanging loose she mistakes them for some quarry her companion is carrying. This is a frequent occurrence, but as a rule the culprit (realizing her mistake) will drop the jesses at once and as often as she repeats the act she will immediately release them. In the second form of disqualification the falcon binds² to the jesses of her captive and they drag each other to earth, where they release their respective holds. In the third case, certain falcons follow another of their own species and try to seize her as if she were a natural quarry; and sometimes the assailant succeeds in binding to her—a serious state of affairs for both. At times the hunted falcon dodges her pursuer, or she may see her enemy coming, wait until she passes, and then seize her. This happens especially when the pursued falcon is herself one that cannot be flown in a cast.

To carry out the necessary test with the lure requires two falconers, both standing in some open space with the two falcons to be tested. Two additional men are needed, who proceed, each with a lure, to a point as far away from the falcons as it is customary for the luring assistants to stand. Halfway between these two pairs of men there should be an extra man, also carrying a lure (or even, preferably, two men, each with a lure). The two assistants farthest from the falcons should be on foot, so that they may come to the aid of the birds in case the latter bind to

² To bind to is to seize and hold another bird, sometimes the quarry of a second falcon.

one another just before they reach the lure. Were these men on horseback the falcons might attack each other before the falconers could dismount and run to their assistance. These two men should stand one before the other as far apart as a strong man can throw a stone. One of them should call the falcon and swing his lure, while the other remains still. As soon as the first assistant calls the falcon to the lure, both men holding falcons should toss them from the fist to fly to the lure—together if they see it simultaneously—but if one bird sees it first she should be released at once, while the second falcon who has not seen it should be slipped from the fist immediately afterward.

When these two falcons have been slipped to fly to the lure, the man (or men) stationed halfway must watch to see whether they bind to (i.e., crab) each other while in flight over the center of the course. If they do, he (or they) must ride rapidly toward them and dismount to separate the struggling birds. In so doing he should place some object between them to prevent them from injuring one another with their beaks. If they sink their talons into each other's flesh, he should loosen their hold by separating the toes and gently raising and freeing each claw. He may now lift one falcon to his hand while placing his body between the two contestants. In this way the falcon on his fist will not be seen by her companion, to whom he must now offer the lure. The second falcon can then be recovered by another falconer.

The two falcons found by this test to be unwilling to fly together are not to be fed at once after they are separated and taken on the fist. A little later they may be lured separately and fed while they stand on the lure. Were they fed immediately, it would be more difficult to make them work together on another occasion.

Sometimes while two falcons are flying toward the lure one tries to catch the other

by the jesses (and she may succeed), causing the second, in her fright, to flee before her; or the leading falcon may turn back to seize the one that is following her, causing the latter to take flight. In such a case the man stationed midway must hasten in pursuit of the birds, swinging his lure and calling out to induce at least one of the falcons to return to the lure. As soon as she has settled upon it the falconer must so dispose his body that the second falcon will not approach the same decoy. When there is a second falconer stationed near him, the latter should at once ride up and lure the second falcon in such a manner that the first will not see the lure. If the halfway man has no associate, the second falcon must be called to the lure by one of the falconers stationed at the far end of the luring ground.

If both falcons pass straight over without binding to each other in midcourse, they may reach the assistant with the lure simultaneously (and at the same speed); or one may arrive before the other. If they arrive together, the lure should be hidden from them both so that they will fly over the falconer. He must now wait to see which turns back first and then throw out the lure to her, but not too far. When she has settled upon it he should run to her and place himself in such a position that the second falcon may not return and approach the same lure. His associate, however, should call her and throw her another decoy. These falcons may, if desired, be fed at once.

The hiding of the lure serves the purpose of determining (as the two birds circle over the falconer) whether either or both may be trusted to fly in a cast. If one of the birds is unwilling to co-operate yet has had no desire so far to attack the other falcon because her attention has been fixed upon reaching the lure, now because the lure is out of sight she may try to seize her companion, since there is nothing to divert her. If she does

so, it must be observed whether she is one of those refractory individuals that temporarily seizes the other by the jesses or one that seriously attacks and binds to her companion.

If one of the two falcons reaches the man with the lure first, either because she is swifter than the other or because she started much sooner, let him hide his implement as she draws near so that she will fly over him. His associate must at once call her and throw out his lure, placing himself between her and the second falcon. As soon as the latter is close to the first assistant he should throw her the lure and take her up in the usual way. Such a flight is not a satisfactory test of the falcons if the first bird is very far ahead of the second and has her attention so fixed on the lure that she is not aware that the second bird is following her. In this instance, the hiding of the bait not only prevents them from binding to each other upon it but gives the falconer an opportunity as they circle about overhead to see whether they will work together or not. As they fly about above him, he can quickly discover in what respect either the leader or the pursuer does not co-operate, or whether they are fit to fly in a cast. In this manner one can determine whether or not a particular falcon will work with another.

CHAPTER XVII

HOW TO TEACH FALCONS TO CO-OPERATE WHEN FLOWN IN A CAST; AND ON THE USE OF THE HARE-TRAIN AND THE MAKE-FALCON

As a preliminary to flying two falcons at a single quarry we have shown that some birds are naturally responsive to this practice and some are not. We have also indicated how two classes of falcons are to be distinguished. Those defectives who do not at once respond to treatment should not be flown, either two or more together, until their de-

ficiencies in this mode of flight have been cured, when both they and those who fly naturally in a cast may be taught to work in unison. We must therefore explain how this is accomplished.

To capture large birds, co-operation in a cast is essential; and this result cannot be achieved without the consent of both falcons.

Let us repeat: There are at least three signs by which birds of prey manifest unwillingness to work together. In the first instance, one bird seizes the other by her jesses but immediately releases them. A second and more serious form of attack occurs when the first falcon binds to the jesses of the second and drags her to earth before releasing her. In the third case one falcon seizes the other, not by her jesses, but in the same manner as she would take her quarry for food. This is the worst possible form of attack, since each contestant may injure the other and not abandon the struggle even if wounded.

Falcons that display unwillingness to co-operate in the first two ways may easily be taught (by a single method) to work in harmony, for both offenders merely grasp the jesses of a second falcon which they later release. However, when a falcon is dragged to the ground the results may be more serious, for then each falcon may develop a hatred for and deliberately assault the other.

There are two causes for one falcon seizing the other by the jesses—hunger and a gluttonous appetite—and the second form of this onset is simply the result of an aggravated form of these incentives. A falcon seizes the jesses of another because it is her nature to attempt to grab the quarry carried by a second bird of prey. As the two falcons in training are novices at this kind of work, one may mistake the jesses of the other for quarry, and fly at and seize her, but, upon discovering her error, at once release the captive.

In training two falcons to work together it helps if they are placed on a single perch as close together as is safe; they may then grow used to seeing and being near each other. To break them of their habit of seizing each other's jesses they should be slipped, one at a time, to fly at a train prepared with a hare in the manner explained below. After they have each been flown by themselves to the train a number of times, and have worked together with the hare-train, their attention will be fastened on the decoy (since it is now familiar to them) and not upon the jesses that both birds wear. This is especially true if on several previous occasions they have realized their mistakes. By repeating this maneuver a number of times the falcons are soon trained to work together in their flights.

The hare-train, for falcons that are being instructed to fly in a cast, is better than that made with a bird; for the hare does not run very far from either a man or a dog. If perchance the falcons do not work together in their flight, a man can then rescue them before they injure each other; and, if a dog sees them binding to each other and runs toward them, through fear of him they will separate. This is not true when the bird-train is employed, for the rapid flight of the bird draws the falcons far from the falconer. If they are of the kind that will not agree over the quarry, and if they capture their prey, their master would be so long in reaching them that they might attack each other. Also if they are unable to seize the bird in the train and, in stooping over it, grasp one another's jesses, they may become angry and attack each other with beak and talons, when, as they cannot be rescued quickly, serious injury may result.

In the third example of a falcon's objection to flying in a cast the incentive is simply her desire to capture the second falcon. As she has not been used to flying with a companion and sees one in front of her, she directs her

efforts to capturing her as she would any other bird under similar conditions. Such a falcon must be flown to the hare-train until she becomes well acquainted with the hare and attacks it eagerly. Flying her to the bird-train is not so effective, not only because she is more easily rescued when a hare is used but for the additional reason that one falcon is less easily influenced thereby to desist in her attack upon another, because a falcon bears a greater resemblance to an avian lure than to a quadruped hare.

As soon as it is observed that a falcon in training performs well in capturing the hare, she should be fattened as much as possible without making her sluggish in coming to the lure. A second falcon who works well with others¹ and is also an adept at capturing hares should now be flown to the hare-train and, while she is still in flight, the trainee must be thrown from the fist to fly with her. But this must not be done unless the hare is in full view. For example, she must not be slipped while the hare is in a thicket or hidden by tall grass, lest, losing sight of it, she attack the other falcon.

The falcon in training when flown after the make-falcon is more eager to hunt the hare, to which she is accustomed and upon whose meat she has been fed, than she is to chase the other falcon whose flesh she has never tasted. If she flies directly to the hare in the company of the trained falcon, all is well and it remains only to repeat the performance a number of times. The newly trained falcon may now be reduced gradually in weight until she reaches the proper degree of leanness for flying at cranes. While this is being done one should find out if she continues to co-operate when her weight is reduced in the same manner as when she was in a fat condition. It sometimes happens that as she grows thinner she no longer works

¹ Such a bird is commonly known as a "make-falcon" or "make-hawk."

harmoniously with another bird. Therefore, as she gradually loses weight, she should be flown frequently with her companion to allow her to get used to working in a cast. If, then, she neither flies to the hare nor attempts to seize the other falcon, she should nevertheless be fed upon the hare when it is caught by her partner. She must then be further reduced, so that she will fly to the hare-train. Thereafter she may be trained to fly with a companion at cranes or other birds.

CHAPTER XVIII

ON FALCONS FLOWN IN A CAST WHO CRAB WHILE STANDING ON THE QUARRY

We have discussed falcons that do not fly well together. Now we must turn our attention to those that refuse to stand peacefully side by side on their quarry. A falcon who grapples with her companion at this time does it through fear either that the latter will carry off the prey or that she will herself be seized. If she is afraid of losing her quarry she spreads her wings and tail over it, bends her head, and turns her back to her approaching companion. If she is afraid of being seized by the new arrival she opens and spreads her wings, faces her foe, flattens her feathers, opens her beak, and fixes her eyes upon her enemy. As soon as her associate reaches her, she attacks with beak and talons.

As for the second falcon, if she comes toward the quarry (upon which the first bird is standing guard) with the intention of feeding upon it, she will arrive with no sign of ferocity but will alight a short distance away and approach the quarry on foot. Or she may fly directly to it and settle there. But a falcon who comes with the intention of seizing another that has preceded her, and who is guarding the prey, will arrive with wings and tail

curved and spread, feathers ruffled, head low, beak open, and staring and contracted eyes, and will immediately seize her associate.

It is difficult to cure such falcons of these bad habits, for as often as they are flown together to take the same quarry they will bind to one another. The oftener this happens the more inimical they become toward each other. Moreover, even if only one of the two falcons that struggle over the quarry is guilty of crabbing, she will contaminate all other falcons that are flown with her. Therefore a falcon that seizes another when on the quarry should never be flown in a cast. It would, it is true, be less dangerous to fly her in a cast at a heron; for then dogs are in attendance and a heron does not fly any distance from either man or dog. In this case, when one falcon seizes another, they soon separate on the approach of the dog (whom they fear) and a man may quickly rescue them before either is injured. Or, because of her fear of the dog, a falcon may not even approach the quarry, or will be looking so anxiously about her that she will not think of seizing the other falcon.

Furthermore, the bird one wishes to test in order to discover whether or not she may be flown in a cast should never be allowed to fly with a second falcon at quarry of the same species it is intended to teach them to hunt; for if a bird of that species is used in the trial and one falcon crabs the other, the falcon that is crabbed will connect her misfortune with that species of bird and will no longer be willing to attack it.

CHAPTER XIX

ON HUNTING WITH THE GERFALCON AND ON VARIOUS CONDITIONS THAT AFFECT HER FLYING POWERS

Now that we have completed our discussion of luring falcons and teaching them to fly in a cast, we shall in the following pages

lay down rules for instructing falcons to capture quarry. As gerfalcons always take precedence in our consideration, and as they must be taught by methods that vary according to their individual characteristics, we shall discuss first the various kinds of gerfalcons.

Gerfalcons are captured as either eyases or branchers, meaning by the latter those that are taken wild after leaving the nest. They may be sorefalcons (unmoulted) or moulted.¹ Such birds may reach us after good or bad treatment, from men skilled or unskilled in falconry. In fact, since gerfalcons come to us a long distance, through various regions, they may have been handled both by those who know how to treat them well and by those who handle them badly.

Power and courage are two qualities requisite in gerfalcons if they are to make good hunters. To be powerful they must be sound in health and must be and must have been well treated. Their courage is derived from a virile will power. For this, also, careful handling is essential, for improper treatment may render them inactive and awkward.

Those gerfalcons that have been brought a long distance, have been badly treated, and have not flown for a considerable time should upon arrival be retired for a period of rest so that they may recover their strength and keenness. For this purpose those falcons that are received in autumn and have been mishandled should be permitted to rest all winter, until early spring; if their feathers are sound, they can then be used in hunting. Although it is possible to fly these falcons when spring comes, we feel we should caution those falconers who do not wish to allow their birds to rest until autumn that it is nevertheless better policy to permit them to remain quiet until the more advanced season. If the gerfalcons one receives in the autumn have broken feathers or bad plumage, it is essential

¹ In this last case the falcon is no longer a "brancher" but is called a "haggard."

to let them rest not only all winter but all summer as well, until they have completed a moult, that is, from one autumn to another. Those with poor plumage that are received in the spring may be flown in the autumn after the moult.

A falcon before her first moult is more seriously affected by bad handling than is one that has moulted, since she is weaker and more frail. The moulted falcon is also less sensitive to maltreatment, even though it lasts over a longer period, for she has been a greater time in captivity and is therefore less gravely injured thereby than is a sorefalcon. A bird that receives bad handling both before and after her moult is much more seriously affected by it than a falcon that has been mishandled only before the moult.

An eyas is less harmed by bad handling than a wild-caught falcon (brancher), because an eyas is more accustomed to the companionship of man, to different kinds of food, and to the unusual eyrie (the mews). She therefore bates less and is not so easily disturbed by untoward occurrences and poor treatment. She finds less cause for uneasiness in the objects about her to which she is accustomed than a bird unfamiliar with them.

The rest period for badly handled falcons should be apportioned as follows: Falcons received in the autumn should be kept the whole winter in a dark room upon the low block we have described. The room should be strewn with straw which the bird may lie upon and which will protect her feet and feathers from injury when she bates. She must be kept from any exertion, allowed to bathe (if she wishes, but always on a fine day), and fed on good meat to keep her fat. Birds received in the spring should be placed in the mews and left there to rest all summer. While in this retreat they should be dealt with in the same manner as all other falcons resident in the mews. This last topic will be resumed later; at present it is foreign to our

subject. We shall then discuss the mews in general and the important theme of moulting.

When they are taken from the mews, falcons received in the spring must be taught to fly and hunt for quarry in the same way as those that were rested all winter. This training we shall now discuss.

CHAPTER XX

ON THE GERFALCON'S PRELIMINARY EDUCATION IN HUNTING, AND ON THE USE OF A HARE-TRAIN

Gerfalcons trained in the same region in which they are caught wild (as branchers) have not made previously a long journey. They may therefore be taught in the same manner as other falcons that do not require a prolonged period of rest. After they have had a short repose in the surroundings we have indicated,¹ they should be taken up, carried about, reduced in weight, and called to the lure in the manner we have already detailed. But in the case of those falcons that have been badly handled and that have not flown for a long time, it may be found that they do not immediately exhibit natural movements of their wings (perhaps through some accident that occurred in bating), for their flight is not normal. It is like a man who has been chained up for a long period; when he is set free, his gait is decidedly abnormal. Such a falcon should therefore be lured frequently from a lower to a higher position, i.e., from a valley to a hill. Luring of this kind, involving upward flight, will often remedy any uneven movement of the wings and restore to them their normal functioning. After this has been done, a horseman should carry the falcon outdoors and look for a hare. For this purpose he will require two good hunting dogs that can be trusted to find the

desired quarry. When the hare is found, let the falcon see it. The hare is preferable to any other animal for this purpose, since few if any falcons are unwilling to fly at a hare. It is in fact almost second nature for falcons to hunt them. Hounds are useful at this point also, for a gerfalcon that does not seize a hare is thereby rendered less keen when loosed at one upon a later occasion. But after a dog has been used to capture the hare, remove it from his mouth and throw it to the gerfalcon. In doing this the dog should be held back from seizing the hare, lest the falcon be frightened and make off.

If the gerfalcon is unwilling to fly at a live hare that is shown her, take the whole pelt of a hare, stuff it with chopped straw (to make it resemble a live animal) and tie some meat between the neck and back of this dummy. Allow the falcon to feed on the meat two or three times in a meadow where the flesh attached to the counterfeit animal is not likely to become soiled as the form is tossed about. When the falcon has flown with keenness and avidity at the counterfeit hare, remove the meat and fasten a cord at least four paces long around the neck of the decoy. An assistant on foot should then take the end of the cord and, running hither and thither, drag the train about the meadow. The gerfalcon should then be permitted to fly and seize the hare-skin. When she has grasped it she must be fed with meat held in the same position as it was formerly tied. This maneuver should be repeated until the falcon flies after the hare-train with eagerness. Then the various stages of instruction should be repeated, with a longer cord and with the assistant, on horseback, racing over the fields until the falcon flies down to seize the dummy. Then the horseman should draw in the line with a jerk, with the result that the gerfalcon misses her mark and fails to seize her intended prey. This will teach the falcon to stoop hard, to fly swiftly, and to

¹ Book II, chapter xxxiii, p. 129.



PLATE 103.—Upper-floor room, Castel del Monte, with remains of a fireplace and cupboards on either side, formerly closed with metal doors—probably used to keep food warm or to dry clothing. This room is considered to have been Frederick's bedroom. It is Room 2, second floor, Plate 30 (p. ci)



PLATE 104.—Antique casket with hunting scenes; Oriental falconry on the left. From the Capella Palatina, Royal Palace, Palermo; probably familiar to Frederick II

throw up² high after striking. This action may be repeated more than once, but not so often that it tires out the gerfalcon, who might if fatigued fly off to another locality.

When this final stage of her training is completed, the falconer should ride out into the fields without the stuffed skin but accompanied by two good and trustworthy hounds. When a hare is found, the dogs should be loosed after it. When a number of hares have been procured and the falcon is flying well in her pursuit of them, one dog should be placed on the leash and (with one dog only) the gerfalcon should be permitted to catch several hares, upon each of which she may be allowed to feed a little. Finally, the single good hound should be replaced by one less swift. In this way the falcon becomes used to longer flights. She should then be flown among plantations and thickets so that she may learn to throw up (*surgere*) to greater heights—a necessary accomplishment in crane hunting.

If it is asked why, when it is intended to fly the gerfalcon at cranes, the train is made of a hare, which is not even a bird, and why it is not made of a goose, or of a member of the goose family, or of a bustard or similar bird (for there is more resemblance between birds than between a bird and a quadruped), the answer is that no other flight³ is more beautiful or more resembles the flight at a crane than that learned with a hare. More-

² Of this "throw up" E. B. Michell (*The Art and Practice of Hawking*, p. 109) says: "this is the counter-move by which she responds to the shifts of the quarry. A good, long-winged hawk, after an unsuccessful stoop, immediately shoots up to a great height above the place where the stoop was intended to take effect. She rebounds, as it were, from the rapid descent, glancing upwards with wide open wings to a new position of advantage."

³ *nillum volare pulcrius est*, Bologna MS., fol. 81^v, col. 2.

over, were the train made of such birds as those mentioned and a gerfalcon were flown at cranes she might find birds of the same species in the fields and fly at them; whereas in utilizing the hare we are dealing with an animal that is unlikely to come running up by itself but is inclined to lie hidden.

In the Island of Armenia⁴ and adjacent lands, falconers, after their lanners and sakers have learned to fly at the skin of a hare, make a hare-train in the following manner: A live, young pig is disguised in the skin of the hare and permitted to run about the fields. The falcon is slipped to quarry and when she has seized the pig she is fed on its flesh, or on other meat if that seems desirable in order to preserve the live pig for use as a train on a future occasion. This stratagem is repeated until she flies well at the pig, and then she is flown at a live hare. Such a scheme is adopted in training saker and lanner falcons, because they are not so courageous as gerfalcones. In the rare case of a gerfalcon who does not fly well at a hare-skin stuffed in the prescribed manner, she may be tried with a pig. After the gerfalcon has been flown at a hare-train, if it is desired to fly her at some bird before she is duly entered to a crane (to make her flights swifter and more daring), it is best to choose such birds as are not found in meadows; for if she is entered to birds that are common in grasslands, especially geese and their like, bustards, and other birds that mingle with cranes, it will be found that when she is flown at a crane she will check and fly at such a bird whenever she sees one.

⁴ It is probable that Frederick is referring here to the Kingdom of Lesser Armenia, founded in the Cilician Taurus A.D. 1080 by refugees from the Seljuk invasion of Armenia. This isolated Christian kingdom supported the Crusaders and carried on trade with Italian commercial cities.

CHAPTER XXI

ON FLIGHTS OF GERFALCONS AT
SMALL BIRDS; AND OTHER PERTINENT CONSIDERATIONS

Before a gerfalcon is entered to cranes it is permissible to fly her at snipe and partridge, since these birds are no hindrance to her flight at other quarry. Snipe may be used because they are not seen at all times of the year as are some other birds. From the extreme northern limit of the fourth climatic¹ zone to the seventh zone they can be found only from about the middle of spring until sometime in the autumn. The closer to the seventh zone, the earlier snipe migrate and the later they return. From the middle of the fourth zone to the first zone they are found during the entire year. Therefore to incite a love of hunting in a falcon she may be entered to snipe in the more northerly regions before she is flown at cranes. If it is objected that when she is slipped at a crane she will check in pursuit of snipe found in the fields, our reply is that when the gerfalcon is entered to cranes, snipe have already migrated and can be found only in a southern area.

Partridges are small birds that lie hidden on the ground and do not fly alone from place to place unless they are put up by men or dogs. Hence a gerfalcon will not abandon her flight after a crane on their account, as she cannot see them easily.

When one possesses a falcon whose flying powers and strength of loins² one wishes to test, she should be flown at the bird that resembles the great horned owl³ and the short-eared owl but is smaller than the former and larger than the latter and is called by the French *huhani*.⁴ Or one may use one of those

many birds whose defense depends on lofty flight, such as the *moha*⁵ or the birds called *albani*.⁶ Screech owls are found in the fields in uncultivated areas and in thickets. They protect themselves by flying high, as they are dilatory during long, straight flights. If a gerfalcon that is entered to a screech owl has strong loins and is powerful in ascent, she will fly at this prey and surmount and overcome it by her high pitch. But if she is not strong, she will be unable to accomplish this feat. When a screech owl is unobtainable, the gerfalcon had better be lured from low ground to a higher position.

We must now return to our discussion of the various types of gerfalcon.

All eyases, whether badly handled or not (either before or after the moult),⁷ must be trained, in the fashion we have described, with the hare-train and by other means. As these immature birds are taken from the nest, they have not learned to fly or to hunt and must be taught by various artifices to fly well and to capture their quarry.

Branchers, also, whether moulted or not, if badly handled are to be instructed in the same manner. Those that have moulted⁸ and have not flown for a long time should also be put through appropriate stages of instruction.

It will be found that little training is required for branchers that have been well handled; for, though they have never hunted, they soon acquire keenness and strength. Similarly, if newly captured falcons are properly treated, there is little trouble in training them; for one does not, in this case, have to counteract bad handling. Also, a long interval not having elapsed since they hunted, they

⁵ *moha* or *moba*, unidentified.

⁶ *albani*; possibly the Italian *Albanella* or hobby.

⁷ Intermewed, i.e., those birds whose first moult takes place in captivity.

⁸ Branchers that have moulted, in the sense in which the expression is used by Frederick, may mean either intermewed or haggard falcons.

¹ Cf. Book I, chapter xxi, footnote 1, p. 39.

² *renes*, "kidneys"; Fr. *les reins*, "loins"; the region of the back.

³ *buboni et noctue*, "great horned owl (*Bubo*) and short-eared owl" (*Stryx*).

⁴ *chat-huant*, "screech owl" (*Scops*).

remember previous experiences. If one wishes to fly them at a bird-train of the species which they are to hunt, it may be done; or, if it is desired to enter them first to some other bird, to test their powers of flight, this too is permissible.

The falconer who is educating a recently acquired falcon should observe closely any evidence of previous good or bad treatment, displayed either when she is on the hand or when flown to the lure, and should govern his further handling of her accordingly.

CHAPTER XXII

ON ENTERING A GERFALCON TO THE CRANE-TRAIN, AND ON THE PREPARATION OF THAT DEVICE

When all this preliminary training has been completed, if the falconer desires to make use of a crane-train he should proceed as follows: The falcon's weight must be reduced until she is fairly thin before she is entered to the train. Those birds that are naturally more eager and courageous have less need of being reduced than those that show less spirit and keenness. One should therefore adjust a falcon's weight mainly to her eagerness to fly, taking care to maintain her strength. It will be found necessary to have her thinner when flown at a train than when entered to free-flying birds or hares.

The falconer should not begin his instructions with a train so early in the season that they are completed before cranes are to be found in the district, nor so late that all cranes have migrated by the time he is ready to hunt them. He may, however, give his falcons these lessons just before placing them in the moult house. This will facilitate their further training when they are again brought into the open.

Lessons with the train should be pursued without any interruption, and once begun they

should be completed in their regular order. A falcon must not be flown to the train one day and then be allowed to rest three or four days before flying is resumed. Everything should be in readiness for this work so that, from the beginning of the lessons to their completion, there is no break in the prescribed sequence.

In practice with the train, birds of prey are taught to take animals of the same species as those of the train and of a kind that falcons do not normally hunt. When made from a living crane, the train is prepared in the following manner: Procure a live crane; and, since that species defends itself with its beak and feet (especially with those slashing talons that we have described), its claws must first be coped and its beak bound to prevent it from injuring the gerfalcon. In coping, the crane's claws are charred by means of a lighted wooden splinter until their sharp (needle-like) points are blunted and thickened; then when the crane strikes no serious injury is inflicted on the falcon. This method of blunting the claws is better than cutting them with a knife, which may cause a heavy flow of blood, weakening the crane and besmearing the gerfalcon when the crane strikes at her.

The beak is rendered harmless by passing a small cord through the opening in the two nostrils and binding the lower mandible to the upper, so that the crane cannot bite. Then the crane must be seeled so as to render her quite blind and unable to see when and where to strike the falcon.

A weak crane may be used for the train at the beginning of the instruction period, but it should be able to stand on its feet.

A too-strong crane may be "carried" in the following manner until she is sufficiently weakened. Two sticks are sewn one into each end of a cloth, and this fabric is used to enfold the crane, whose feet and legs are bent beneath its body in the sling. The sticks are brought together over the back of the crane

from the tail to the shoulders, near the neck. The two upper extremities of the poles are then bound together by one end of a cord whose opposite end unites their lower extremities near the crane's tail. In this fashion the bird may be slung by the cord placed for that purpose around the carrier's neck. While being carried, the crane's head and neck should be turned toward the carrier's back; for were it directed forward the imprisoned bird would still be able to strike at the assistant's eyes, especially when the crane is not seeled. The crane's efforts to escape, the carrying about, and the bending of its legs in the sling, which causes pain in the knees, all contribute to stupefy and weaken the bird to a point where it can be utilized in the train.

When all this has been done and the crane is sufficiently weak, one should place two leather straps, like the jesses of a bird of prey, on the feet of the crane. Each of these straps is joined to a cord two feet long, the opposite end of which is fastened to a single cord at least ten paces long and the size of the shaft of a goose quill. A further requisite is an iron stake a foot in length with a sharp point and a head large enough and flattened laterally to provide space for a hole the size of a man's thumb.

When these necessities are all in readiness, the crane is carried to a meadow or a flat grassy place where the herbage is short and sparse. See to it that the crane's claws, beak, and eyes are prepared in the manner we have just described. Place the straps on the crane's legs and tie them to the cord. Then drive the stake into the ground up to the hole, into which insert the cord. Now draw the latter all the way through—even to the knot joining it to the straps. The long, loose end should be stretched out at right angles to the wind. Meat is then tied to the crane's back between its wings. For this purpose, use a cord passed over the back of the captive in front of the wings, and draw each end down under a wing

and up again on to the back, where the meat is fastened to the ends of the cord. The crane is now set on its feet and turned to face into the wind. One man stands at the end of the cord stretched across the wind, while a second falconer stands holding the gerfalcon at such a distance behind the crane that she can see the meat on its back. A third man takes his position near the second assistant on the side away from the hand holding the falcon.

If the gerfalcon wears a hood it must not be removed until all is in readiness for the chase. Then she is unhooded and the crane is shown to her. If she is not hooded, she should not be permitted to see the crane until everything is prepared. To this end, the falconer should interpose his body. If, when the falcon sees the crane, she wishes to fly at it immediately (because of a desire either for the crane or for the meat), she should be permitted to do so.

CHAPTER XXIII

THE EDUCATION OF THE GERFALCON WITH THE CRANE-TRAIN

While practice with the train is in progress, no one, either on foot or on horseback, should be allowed to pass in front of the crane lest the gerfalcon check and fly to the interloper in expectation of being given the lure. If she does not fly at the crane, either because she does not see it or because she has no desire for it, the third man who has been standing beside the falconer should approach the crane, seize the tip of a wing and move it up and down to induce the falcon to fly. This may be done also if she fails to see the meat.

When the gerfalcon does not respond at once to this procedure, either because she does not see the meat or because she does not wish to fly on account of the distance, the falconer should go close enough for her to see the meat. By thus arousing her desire for it the

falcon will probably be induced to fly to it. When the falconer is convinced of this craving he should release the falcon and let her profit by it, but he should not urge her in any other way. When the assistant who is holding the crane's wing sees her coming, he should slip off sideways from the crane; for if he stands too near, the falcon may check from fear of him. As soon as the gergefalcon seizes the crane, or the meat on its back, the assistant holding the long end of the cord must pull it through the eye of the stake until the feet of the crane are drawn so close that the bird falls over. Even then he must not relax his hold. If he does, the crane will somehow free its feet, strike at and seize the falcon, and injure her.

The third man, who held the crane's wing and has now stepped aside, as he is nearer than the other two, should approach the crane and keep it quiet on the ground; for though the crane cannot strike the gergefalcon with its talons it may be that its unaccustomed movements will terrify the falcon and cause her to fly off. If the falcon does not seize the meat but the crane instead—and the falconer has another crane suitable for use in the train—the gergefalcon should be allowed to kill her quarry by strangulation. When she has killed and plumed it, the falconer must extract the heart from the prey. If the heart is firm and has fat on its upper surface,¹ he must pierce the skin with a knife (since it is tough) and permit the falcon to feed also upon the flesh of the breast. If the heart is not firm, the falcon must be fed not upon the crane's flesh but on other meat that she likes. In feeding it to her, slip the hand holding the food under the feathers of the crane's wing in such a way that the meat protrudes from the plumage while the hand remains hidden. The falcon will then think she is eating the crane's heart. Allow her to take only a little food, so that

¹ A sign that the crane is healthy and its flesh fit for consumption.

she can be exercised with a similar train on the following morning. Her meal, of whatever meat it is, should be the equivalent of a chicken's leg.

The next morning a similar train should be prepared of the same crane or, if it was killed the day before, of another bird. If the gergefalcon does not fly better at the train on the second day, the operation of the latter should be carried out exactly as on the first day except that the falcon should not be allowed to kill the crane. This rule should prevail each day until she flies better and with greater keenness.

When it is observed that the falcon is improving and makes better and more spirited flights and is ready to fly before the crane's wing is moved, whether this be on the second or any subsequent day, then the falconer who is holding her should stand a little farther from the crane. The assistant who moves the crane's wing and the man who holds the end of the train cord should now hide behind a thicket, or in a hollow, to prevent the falcon from seeing them and flying to them in the hope of being fed.

As soon as it is evident that day by day she is flying better and with greater confidence at the crane attached to the train, the falcon's ration should be increased a little to add to her weight; for she must not be kept so thin that she is weakened and unable to accomplish what is expected of her. Whenever any alteration is made in these training practices she should be allowed to become a little heavier, but not so much so that she loses her keenness in seizing the crane.

On the occasion of the first flight, after the gergefalcon has recognized the crane without having its wing moved to and fro and has flown eagerly to it, the quantity of meat attached to the crane's back should be reduced slightly and the falcon should now stand at such a distance that the falcon on his fist cannot see the meat. As she approaches in her

flight she will, however, espy it and seize it hungrily. At once the man at the line must pull it in, to make the crane fall over, and the third assistant should then run out to give aid, as we have directed.

When the falcon flies to the crane without delay as soon as it is shown her, the train may be prepared with no meat at all attached to the crane, and the better she flies the farther she may be called.

If it seems desirable to fly the same or another falcon to the train in the same locality as before, be careful that there are no crane's feathers (or those of any other deplumed bird) lying about, or the bones or flesh of such birds, for fear the falcon may abandon the crane to investigate these strange objects.

Sometimes a gerfalcon will come to the crane but will not seize it. This is because so far her incentive to approach the decoy has been the meat she expects to find and not the crane itself. As she sees no meat, she will merely settle on the ground near the crane. In this case the flesh has been removed too soon, i.e., before the gerfalcon has acquired sufficient keenness in flying to the crane. She will then stop near the crane and walk around it, looking for the meat. Wait and see if she attacks the tethered bird of her own free will. If not, move the crane's wing in the usual manner, letting the falcon remain on the ground until she mounts the crane of her own initiative. If she refuses, take her up, if possible without offering the meat. Should this fail, show her the tiring and take her on the fist but do not allow her to feed until near evening. Before this is done, give her a last chance to fly to the train and, if she will not approach the quarry, feed her on washed meat,² say a little less than half her usual portion.

The following morning try again to fly

² The English falconer's term for what Frederick II describes in the phrase, *pascat ipsum de carnibus non bonis et madefactis*.

her to the train; and if she will not then seize the crane, take her up and go some distance off. Make the crane fall to the ground (by drawing in the attached line) and then move its wing. This motion of falling and the wing movements may incite the falcon to grasp the quarry. If so, allow her to deplume the crane before feeding her.

When there is a sparse supply of cranes and the falconer does not wish her to deplume the one in use, he should place a lure on the crane's back and allow the falcon to tear at it. He may then give her meat, holding it under the crane's wing and permitting it to protrude from between the wing and the back while his hand remains invisible. We recommend this method, as it is inadvisable to call gerfalcones to the train with meat after it has once been removed.

When the falcon has been called to the crane-train on foot and without meat, and she is flying well to it, the falconer should mount his horse and have her called to the train from horseback, allowing her to fly in the same manner as he did when he was on foot but increasing the distance day by day until the space between the mounted falconer carrying the falcon and the crane is that of a bowshot.³ Such a distance is sufficient. After the gerfalcon has seized the crane the horseman should ride up quickly to give assistance, lest she struggle with it in vain.

When the train is prepared with meat tied to the crane, the falcon may be flown once each day; but when no meat is used she should be flown only every other day.⁴ On the day she is flown to the train she should be given a full meal while standing on the crane. A smaller meal of washed meat is given on the

³ The shot of an English longbow was 300 or 400 yards.

⁴ The Latin expression is *de tercio in tercium diem*. The days are counted, however, in the following manner: The first day is that on which the falcon is flown, the second that on which she rests, and the third the day on which she is again permitted to fly.

intervening day. The larger meals, given on the days she is flown to the train, will keep the falcon strong and increase her taste for the crane; the hunger induced by the small meals of the alternate days will whet her appetite for the crane food on each succeeding day. The days of fasting and rest should alternate with those of practice with the train. On the latter occasions she will improve her bodily condition by a full meal, and on the former her appetite is increased by fasting.

When cranes are abundant and the falcon takes the prey boldly the first time after removal of the meat from the decoy, she should be permitted to kill it and then the procedure should follow the program we have indicated above. But if cranes are scarce the falconer should have on hand a wild pigeon, ash-colored like the crane, which he thrusts up under the wing (between it and the crane's back) as he did with the meat. He must hide the head and feet of the pigeon, so that the falcon will not recognize its nature. She must then be allowed to deplume and feed upon the breast of the pigeon.

CHAPTER XXIV

HOW TO TEACH A FALCON TO RECOGNIZE THE CALL OF THE CRANE, AND ON OTHER MATTERS PERTAINING TO THE TRAIN

As it is an advantage for the falcon to recognize the cries of the crane (upon which she is accustomed to feed) the falconer should lay bare¹ a crane's larynx as close to the mouth (or jaws, *fauces*) as possible, and remove its heart. No other incision should be made in any part of the body, except that as the larynx is to be drawn out after the first cut is made, the skin of the crane should be slit a little downward from the opening (at the throat). The falconer should then grasp the end of the pulmonary tube and blow into it, inflating the

lungs and trachea with air. Taking care not to allow the air to escape between his fingers, let him pinch the end of the larynx, near his mouth, and remove it from his lips. When he wishes to imitate the voice of the live crane, he has only to compress the sides of the bird and release the end of the tube held in his fingers. The crane will then emit the same call as the live one. This scheme may be repeated whenever one wishes to hear the cries of the crane. If one desires to keep alive and uninjured a crane used in the train, the dead bird may be substituted for it without the falcon suspecting the subterfuge. Moreover, when a gerfalcon is permitted to feed upon a crane used in training, the dead crane may be placed near her while she is engaged with her meal and made to call out in the manner we have described. While these call notes are being made the wing of the crane upon which the falcon is feeding must be moved to make her think the quarry is still alive and giving voice.

During the day of fasting the falcon should be fed on a little washed meat. This diet resembles the flesh of young chicken, has little nourishment, and is insipid to the taste. On the third day, remembering the good food she consumed while feasting on the crane's body, she will fly eagerly to it, hoping always to receive the same satisfying meal.

When train practice is being carried on with a crane that has no meat attached to it, and the time arrives when the falcon is eager to leave the fist the instant she observes the crane, even though she does not see it well (since it does not move), then she is ready to be flown at a walking crane whose jesses are removed but who has not yet been unseeded or had its mandibles freed. When such a crane is shown to the falcon, if she looks now at the crane and then elsewhere, rouses, defecates, and behaves generally as if reluctant to fly at her prey, these signs indicate that she is not yet ready to be flown at an ambulant crane.

¹ *excarnare*.

CHAPTER XXV

THE USE OF A WALKING CRANE IN
THE EDUCATION OF THE
GERFALCON

When a falcon is to be slipped at a walking crane, the strap should be removed from the crane's legs and it should be allowed to direct its steps into the wind. The falconer should take his stand half a bowshot from it; for, as the crane is moving away from him,¹ it is best to be near it at the start.

The crane must not be too strong; in fact it should be as weak as possible and yet able to walk. Attention should also be given to the seeling lest the vision be unequal; for if the crane be allowed to see slightly with one eye and not at all with the other, it will, in walking, move more toward the side on which it has some vision and so will not walk straight into the wind but will turn toward the gerfalcon. This result will render the latter more timid in her approach, for few birds of prey will attack a quarry with which they are brought face to face.

Following any change in the use of the train, the gerfalcon may be permitted to kill the crane if there are others available for further train practice. When she has done this, one should proceed as before. If there is no reserve of cranes, give the gerfalcon a pigeon and keep the crane alive.

When the gerfalcon is flying boldly to the crane, it is in order on the third day to employ a stronger crane and with it prepare the train. If a more robust quarry is not at hand, use the same crane whose strength has been previously increased by good food and rest. Then, when the train is ready, let the falcon fly to the decoy from a distance greater than she has yet flown.

A prompt and courageous attack by the gerfalcon on the crane is characterized by

¹ *Mutat sibi modum illum*, referring to *contra ventum*, which precedes this sentence.

the following behavior: When the falcon sees the bird, she leaves the fist at once and flies eagerly toward it. Having gained a good hold, she will not release her grasp despite blows or other defense the crane may put up. Or if the crane does drive her off, she returns again at once to seize her quarry. This part of the training should be continued for several days, until the foregoing signs of improvement are in evidence. Then the next stage may be taken up.

At this point it is well if the seeled crane can be made to run with outspread wings. Thereafter the seeling threads may be removed and the two ends of the cord that passes through the nares and binds the mandibles should be tied together behind the crane's head. This precaution serves to bend the beak slightly downward toward the neck and to hold it in a position which prevents its use as a weapon. Indeed, the crane's mandibles ought always to be tied and drawn down in this fashion, to make it impossible for the captive bird to open its beak or to stretch its neck to strike at or wound the falcon.

CHAPTER XXVI

ON ENTERING A GERFALCON TO A
CAPTIVE FLYING CRANE; ALSO
HOW TO POST ASSISTANTS

If the gerfalcon is one that can be flown in a cast with another gerfalcon (or other falcon) and she now takes cranes that run and flap their wings, she is ready to be flown with a second falcon that is considered a good hunter of cranes. She has had adequate practice with the train, but it is better nevertheless to give her assistance when she is first entered to a flying crane. If, however, she cannot be flown in a cast, exercise her first with a crane whose feet and beak have been prepared according to our instructions—one that cannot injure the falcon. Then let her



PLATE 105.—Doorway and arch of Castel del Monte. Doorway formerly giving on to the balcony that ran around the courtyard on the second-floor level. An example of the mixed architectural styles employed by the Emperor. It shows fine Gothic crotched capitals and moldings combined with classical acanthus foliage in the archivolt, surrounded with a band of classical laurel or bay leaves. While in general design the portal is more Roman than Gothic, the recessed well arch strongly recalls Sicilian-Norman-Saracenic influence.



PLATE 106.—Tomb of Roger II, first King of Sicily, and maternal grandfather of Frederick II

be exercised alone with a flying crane, since she will not fly in a cast.

Carry the crane out to a flat area, where there are no ditches, hollows, water, swamps, or other obstacles to prevent the falconer giving prompt succor to the falcon when necessary. In such surroundings the gerfalcon will not be intimidated by the proximity of water and marshy ground in which the crane is accustomed to seek refuge. The falconer must be accompanied by a number of assistants to carry the crane. On this (first) occasion the latter should be seeled, if it will fly in that condition; if not, the seeling threads should be removed to allow the bird to open its eyes; but the ligature of the beak, that is tied behind the neck, should be retained. The crane is then placed on the ground with its beak pointed into the wind and with the man who holds the gerfalcon stationed downwind behind the crane. When the assistant in immediate charge of the crane has set it free to fly, he must at once hide himself behind the horse of the mounted man stationed near by, lest the falcon, seeing him on foot, desert the crane and follow him, hoping to be fed; for a falcon is attracted more readily to a man on foot than to a horseman. In addition to these assistants more horsemen should be employed, one posted to windward ahead of the crane, another to the right, and a third to the left of the quarry, so that no matter in which direction the bird flies, or turns, a man on horseback is at hand to give aid. These horsemen should, however, keep as much out of sight as possible, so that the gerfalcon may not check in her pursuit of the crane.

This posting of men to lend assistance is desirable because the crane now in use is stronger than those previously employed and the flight of the gerfalcon is longer. She is thus more exposed to injury if not soon rescued.

As soon as the falconer holding the gerfalcon sees the crane rise, he shows her the

prey and (at the proper time) slips her to fly at it. If the disabled quarry cannot rise, it must be permitted to shake itself, rest, and walk about a little. When it has thus rested, the horseman near it should ride toward it. Seeing him come the crane will at once fly off, if it can. Now is the time to slip the falcon. The horseman near the crane must allow the approaching gerfalcon to pass over him, going toward the crane, before he moves from his position. Should he ride off before the falcon has flown well over him, she might check at him in the hope of receiving food. When she has passed he must ride fast after her to give any needed assistance, for he can reach her more quickly than the falconer who slipped her. In giving aid he must hold the crane by its feet so that it cannot injure the falcon. The gerfalcon is now allowed to kill the crane and from it make a good meal. This plan is to be repeated on the third day; and on the intermediate day the falcon's food is to be reduced.

These exercises may be repeated every other day with stronger and stronger cranes as long as the gerfalcon takes the crane boldly. Having once flown her at a strong crane, she must never be given a weak quarry; for this leads to bad habits.

The education with the train must not be performed from start to finish in one place. In fact, the same training locality must not be used more than twice. Cranes are not always found in similar haunts. One must therefore vary the training ground to suit avian peculiarities. Were the gerfalcon trained always in the same environment and then slipped at a crane under different conditions, she would be unwilling to fly because of the unfamiliar surroundings.

We have already stated that when a new procedure is introduced in the training of the gerfalcon she should be fed in such a manner that she adds a little to her weight, so as to make her a little stronger when flown to

the train. In case she cannot be flown at a crane for several days on account of inclement weather, unsuitable ground, because no cranes are obtainable, or for any other reason, the gerfalcon should be kept in such a condition that if it is necessary to reduce her food to make her sharp-set she will nevertheless retain her strength.

The method we have described for the education of gerfalcons is adapted to the less spirited of them. A courageous falcon will not require such long, continued training.

While a falcon is being flown at the train she must not be called to the lure nor entered to any other prey, for such practice interrupts and brings to a standstill her exercise with the train, thus making it of little educational value. Furthermore, unless the weather is bad, there should not be a delay of several days after the gerfalcon has completed her practice with the train before she is flown at a free-flying crane. In case of unfavorable weather, especially if it looks as if it were to be of long duration, the falcon's food must not be increased enough to make her fat and unwilling to fly at cranes when good weather returns. Nor, in the belief that the adverse weather will last only a short time, should her food be so reduced that when the weather does improve she has lost her flying powers. The gerfalcon's condition must be maintained between leanness and fatness in this manner so that when the skies have cleared she will be both eager and effective in her chase of the crane.

CHAPTER XXVII

ON THE VALUE OF THE TRAIN IN THE EDUCATION OF THE GERFALCON

The value of the train will now be explained. Many of those who are unacquainted with the use of the train ask of what value it is when gerfalcons, falcons, and other birds of

prey not only are able to capture cranes but also have the courage to attack them, or any other bird, without practice with the train. The reply is that when birds of prey attempt to take cranes or other large birds to which they have not been entered, it is because they are induced by their bold spirits to feel that they can conquer such quarry in the same way that they have overcome smaller birds, just as an eyas will fly at unknown prey in ignorance of what may befall her.

When a gerfalcon, without preliminary practice with the train, is entered to a crane and captures it, she may be cheated of her reward because the quarry inflicts some wound upon her that makes it impossible to retain her hold. This mishap renders the falcon unwilling to fly at a crane on a later occasion, not only because of the injury she has received but because she has not even had, as a reward, a taste of the crane's flesh or of any other meat. The oftener she is flown at a crane in this fashion the less eager she will be to fly at such quarry. It therefore becomes necessary to exercise her with the train. She now discovers the crane attached to the line to be a weak bird, and when she is again entered to a free-flying, wild crane she is unwilling to attack it because she has learned by experience that it is much stronger. In this manner she develops the bad habit of refusing to fly at a wild crane, since she is able to distinguish it from that used in the train. For this reason it is only before they are entered to wild cranes or other large birds that the train is useful in giving instruction to both timid and courageous falcons. Few high-spirited falcons are found willing to fly to such birds without the train, but even timid ones may be taught by its means to capture birds that courageous falcons will not undertake without previous exercise with the train for fear some harm may befall them.

Although some gerfalcons and other raptors are so timid that they cannot be per-

suaded without the inducement of meat to attack a crane fastened to a line, nevertheless the falconer will discover the advantages of the train if he will follow carefully the various stages of instruction with that decoy. He must educate the novice, first with meat on the crane, then without it; he must pass in his lessons to his falcons from the employment of very weak cranes to those so strong that they differ little from wild ones; and then he must practice the various methods of training that we have described in such a way that the falcon experiences only pleasant results, such as being fed on the crane (or on good meat while standing on that quarry). And as the falconer follows all our instructions his bird must be protected from accidents. She will then become so habituated to good results that in case she fails, through lack of assistance or some accident, to capture a crane at which she is flown, she will not thereby be rendered overcautious in future flights. Thus the effect of previous successful operations will prevail. This would not be the case were she flown first to large birds without practice with a train, for she would then have no memories of former happy experiences.

CHAPTER XXVIII

ON HOUNDS USED IN FALCONRY

When the gerfalcon is to be taught to capture the larger aves whose size and strength greatly exceed her own, she should be given every possible assistance; and even this is barely effective against the size and power of big birds, for the help of man is not sufficient or prompt enough to contend with the speed of the quarry and the distance they can fly. When human aid is delayed, the crane, for example, may wound the falcon or drive her off. She will then no longer be keen to capture her prey. It is therefore necessary to

devise some more rapid means of succoring her.

The dog is the animal among all others that can most easily and fully be taught various helpful maneuvers, and is the animal best suited to receive instruction from man. He has good judgment and an unusual memory,¹ by which he masters and retains what is taught him. He learns also to discount whatever seems contrary to the lessons so imparted. Hence the idea is rational that dogs are capable of assisting falcons when on their quarry, and it is reasonable to conclude that no other domestic animal can be of such skillful assistance as our canine friend.

Moreover, while dogs in general are the best fitted among all animals to give quick assistance to falcons standing on their prey, a particular kind of dog may be more valuable in this emergency than any other. There are, in fact, breeds of dogs that are more decidedly useful in this regard than any other variety. These strains are called harriers² or greyhounds,³ and they should be used, mainly because of their speed, in assisting falcons. It is well also, if they can be procured, to use that special breed that has been trained for generations to assist in the chase, and whose natural qualifications have been thereby augmented.

A hound to be trained in hunting birds should be about a year old. Before it reaches that age its limbs are not strong enough to stand the work. If it is much older it may meantime have acquired bad habits either through its own inclinations or from association with its fellows. These defects are not easily overcome. It is wise to choose dogs of medium age for the additional reason that it is impossible to decide whether or not

¹ *Virtutem estimativam* (i.e., *existimativam*) et *conservativam*.

² *Leporarius*, a hare-hound or harrier.

³ *Veltres*, *Valtres*, a kind of greyhound. *Veltre*, Old French.

younger dogs possess certain serious physical defects.

A hound's body should be thickset, with a good coat of hair, so that it can endure hard work and resist the cold. Such a dog will also have less dread of rough ground and of a bad climate. The chosen hound should be of medium height; if too small, he is unable to see over long grass and shrubs; if too large, his weight is a hindrance to effective work, as well as a danger to the falcon if he dashes impetuously against her or treads on her. He should be so agile that he will not readily tire, and must be prompt in executing his tasks. He should be a male, as he must constantly be in condition to attend to his hunting duties. With a bitch this is not the case, for during the mating and breeding season she tends to be careless and lacks strength in giving aid and when in heat might spoil other trained dogs. Also, of course, when carrying young she would be unable to endure fatigue.

The hound must be brave and have no fear of wading or swimming through water or of running over difficult ground across which the falcon has flown. He should be quick to understand what is taught him and to avoid what is forbidden. He must be obedient to his trainer and endeavor to learn to execute commands and so avoid trouble.

The chosen hound must not have been previously employed in hunting quadrupeds; for, as dogs are naturally prone to hunt animals other than birds, such hunters are not as keen for avian prey as those that have never hunted four-footed creatures. Also, if such a dog, while following a falcon, sees a small animal that he has been accustomed to chase, he will desert the falcon and run after the former.

It is an advantage, also, if the falconer himself can feed the dog while it is young and make it familiar with falcons. Harriers that are to be trained in this manner should see falcons frequently and be near them, so

that they may recognize these birds of prey and distinguish them from other species both by their odor and their appearance.⁴ However, the falcon should not be allowed to see the trained hound too often, for she will then wait for him while standing over the captured quarry. It is just as well that she be a little afraid of her helper. She will then not stand still upon his approach but will withdraw a little; for not all dogs are well trained or have good habits, and there is a possibility that in the long run a hound may injure the falcon on the quarry if she waits for him in that position. It is better, therefore, if she be rather timid and stand off a little from the crane.

Whenever the falcon is fed, the dog should be present, to make him realize that she is dear to his master and that he must not harm her. As a rule a dog is afraid to injure anything that is cherished by man, especially if he has been fed near and is familiar with it. Therefore, when the falcon is fed, the dog should be given cheese, bread, or other food that he likes. This food should be handed him from beneath the fist on which the falcon stands; i.e., he should take it in his mouth almost under the falcon's feet. Now when the falcon has grasped the quarry, the hound will dash at the crane under the falcon's feet and not direct his attentions higher up at the falcon herself, since he has been accustomed to find his food under her feet.

Inasmuch as dogs recognize all objects by means of their sense of smell as well as through sight, the hound should be made to sniff the falcon so that he may distinguish her by her odor from other birds. If while he is smelling her the dog tries to injure the falcon by biting or otherwise injuring her, the falconer must scold or threaten him. The falcon

⁴ Frederick well knew that the dog depends for recognition of objects much more upon his extremely acute sense of smell than upon his comparatively poor vision.

at whose feet the hound is taught to feed and with whom he is to become friendly must not be a falconer's pet and, above all, not the falcon the hound is to assist in hunting. The latter bird should be kept a little afraid of the dog.

When these instructions have been followed for a number of days, give the young dog cheese to eat on the lure, repeating the snack several times until he becomes well acquainted with the lure and comes readily when it is shown him. The next step is for the falconer to hold the falcon in the same manner as when she is called to the lure and to have the dog near him on a pigskin leash.⁵ A second falconer should carry the lure a stone's throw away in an open space and hold it well in sight of both the falcon and the hound, giving the decoy a few turns without calling out. The falcon carrier should then slip the bird to the lure in sight of the hound, holding the latter back so long that he will be unable to overtake the falcon, and then set him free to follow the bird. As soon as the falcon draws sufficiently near, the lure is tossed to her. The falconer who threw it must then place himself between her and the dog, to prevent his going to the lure (where he is accustomed to be fed); for the falcon would be frightened if she saw him coming and would abandon the lure. Also on another occasion she would not come so easily to the lure. The falconer must now catch the hound and lead him to the falcon so that he will see her standing on the lure. He must be fed in her presence on cheese, bread, or other food he likes. Next the dog and falcon must be again called to the lure, this time at a greater distance. This maneuver must be repeated frequently, calling them farther and farther each time until the dog starts to run with the falcon of his own accord as soon as she is slipped at the quarry.

The next step is to station the assistant

⁵ *fune layatorio*. Laya, "wild sow."

with the lure far away in some position where the hound cannot see him even when he whirls the lure. As soon as the falcon has been slipped the dog is released and must quickly follow the falcon in order to reach the man using the lure. This ruse is repeated frequently until the hound follows the falcon eagerly and without delay.

At this juncture, procure, if possible, a wild goose (if not, use a domestic one) that the dog will bite, and if he refuses to do this of his own accord give him some cheese on the goose and he will bite it eagerly. The falconer should then carry the goose into a field and tie both her wings (so that she cannot strike with them) and allow her to run about the field on foot. Then allow a falcon (one of small value) to capture the goose. Let her fly to it; but wherever the goose may go, post a falconer. Then set free the dog that he may follow the falcon. Before he reaches the goose, upon which the falcon is now standing, the nearest assistant must catch it with his hands and when the hound comes running up he must admonish him, to check the impetus of his course and to teach him to approach gently so that he will not collide with the falcon. Now let him, beneath the feet of the falcon, bite the goose. When the falconer holds the goose to be bitten by the hound, let him be careful to hold it tight and close to the ground so that the dog cannot carry it off and worry it. In this way the hound learns not to carry off the quarry, nor to worry it, but to hold it down (for the falcon). If the hound bites the goose with relish, he should not be given anything to eat upon it, but he should be praised and his head stroked while he is performing his task.

If the hound worries the goose, the falconer must scold and threaten him; and he must repeat his rebukes and threats until the dog abstains from shaking the goose when biting her. When the hound has reached the point in his training where he no longer wor-

ries the quarry, the falconer, who up to this time has stood near the goose, should allow the dog to come directly to it without stopping him and without himself holding it down. He should in fact stand a little way off. When this stage is safely passed, the falconer may allow the hound to run with a falcon to the crane, but only with one that is used to taking cranes and may be trusted to capture this one expeditiously. For should she fail more than once to do this the hound would no longer be eager to run with her, and

would be demoralized as a helper, having had his labor in vain.

Such hounds as these should never be permitted to kill any domestic or wild animal, especially animals that defend themselves with their teeth, such as wolves, foxes, and cats. For if he catches such beasts he will learn to shake, or worry, the quarry when he is sent out to assist the falcon, and this would endanger the latter as she stands on her prey. She might then have her feathers broken or be even more seriously injured.



PLATE 107.—*Hierofalco hoeboulli*. Adult male (after Keulemans)



PLATE 108.—Greenland falcon, *Falco candidans*, Gmelin. Adult female

BOOK IV

CRANE HAWKING WITH GERFALCONS AND OTHER FALCONS

CHAPTER I

ON CRANES AND THEIR FEEDING HABITS

THE TRAIN, how it is prepared with a crane, and its use in teaching falcons we have described. In addition we have explained how to train a dog to assist the falcon. Our present task is to show how a gerfalcon is taught to hunt cranes. But before we can do this it is important to know where cranes are generally found, for they shift their habitat with the changing seasons, the hours of the day, and the prevailing weather.

First of all, let us describe the regions in which one may expect to discover cranes at various times of the year and discuss at what hours of the day and in what weather it is best to hunt them.

It is generally agreed that cranes go out to feed twice a day. They may be seen from dawn until the third hour,¹ and sometimes until the fourth if the day is cloudy. But on overcast days they both start out and return later from feeding. After the third or fourth hour a sense of alarm causes them to return to their retreat in or near the water where they rest and drink. At the ninth hour² they again come forth to feed until sunset, when they go back to sleep on the water where they are safe.

¹ Nine o'clock in the morning.

² About three o'clock in the afternoon.

In the early autumn, before the sowing of the crops, cranes are most frequently found in open fields, especially in those places where men thresh the corn;³ and sometimes they are seen among the stubble. In regions where corn is not threshed in open fields, cranes are found more frequently among the remains of crops irrespective of the kind of grain but most often among millet stalks.

In cold regions, after the autumn sowing, cranes are to be found in newly planted fields, where they remain until both earth and water freeze; thereafter cranes are scarce and are seldom seen. In warm countries cranes are to be had in planted areas until the germination of the seed. After the sprouting of the grass in those districts where the birds pass the winter, cranes are more often detected on unbroken and uncultivated ground, where they dig among the roots. In early spring, in regions where sowing is not done at that time of year, cranes may be found in meadows and on uncultivated ground. If the district is one where planting is in progress, they are more frequently seen on land where vegetables are being planted or in fields sown to grain. There they stay until the seed germinates and grass springs up. After that they again seek the meadows, swamps, and reed beds. In summer cranes are numerous in meadows and swamps, near marshlands, and in plowed fields that have not been sown.

³ That is, any kind of grain.

After the rains (i.e., when it has stopped raining but the sky is still cloudy) cranes are often found in fields from which they are reluctant to retire to more watery resorts. If the weather is fine, unless there is frost, they come out earlier to feed and are ready to retire early. In a mild climate on days when there is frost in the morning, the rising sun soon melts it. Here, although the weather is fine, cranes postpone their search for food until the ground thaws and they can more easily dig for worms. On returning to the water to rest on fine days they fly high and circle about before settling on their aquatic shelters; but on cloudy days they fly directly to these resorts.

Cranes feed almost all day long on rainy days if there is no wind. On windy days they nearly always return quickly and gladly to bodies of water, for along the shores there are generally willow thickets that protect them from wind and cold. Cranes are of a cold nature and fear frigid weather, and they have long legs that expose them to the wind. On windy days they may also be noticed feeding quietly in the lee of hills (that protect them from stormy blasts) or in other localities where wind cannot disturb them.

Some cranes are large and have ash-colored plumage and a red, featherless head. Their call is sharp and high. These are the best-known—they are, indeed, quite common.⁴ Another variety⁵ is small, ash-colored on the back, with red eyes and feathers of the nape long, like the heron. In this species the head is neither red nor bare. The knees are white and the feathers on the breast are black. They have plumes on the breast that are separated, like hairs. Their call is raucous. The sexes differ little in plumage and structure.⁶ Still other cranes are white and large; they are, as

⁴ *Grus grus*, common European cranes.

⁵ *Anthropoides virgo*, Demoiselle crane.

⁶ *in reliquo vero plumagio et in forma membrorum parum diferunt a maribus*. Bologna MS., fol. 89^v, col. 1.

a rule, the size of the other large cranes, and may be even larger. They have black-margined feathers on their wings, but are entirely white elsewhere.⁷

CHAPTER II

ON THE SEASONS BEST SUITED TO CRANE HAWKING IN VARIOUS REGIONS

We have related where and in what kind of weather cranes are most often found. We must now recount what seasons (in various districts) and what hours of the day are best suited for hunting them.

As a rule in autumn and spring cranes are found abundantly in both temperate and cold climates. In winter many seek hot countries. If they are found there in larger numbers in the springtime, it is not because they have migrated thither from other climates but because those individuals that have been scattered over an extensive region are now collected in flocks to journey to their nesting places, as we have explained when describing the spring return of birds.¹ As we have already stated, cranes are not found in the coldest climates during the autumn, because then they are migrating. Nor are they to be seen there in springtime (when they are making their return flight), nor in winter. We have also given the reasons why there are no cranes in hot countries in summer. At that time they are to be sought in cold climates.

In warm regions cranes are seen all winter. For many reasons, therefore, the autumn is the best time to hunt cranes in any region. They are more widely scattered then than at any other season; the weather is generally dry and the ground less muddy; swamps are not then so serious an obstacle, and in the autumn

⁷ Species unidentified.

¹ Book I, chapters xxiii-A and xxiii-B, pp. 42-44. These chapters are not in the Vatican Codex; see Bologna MS., folio 12, col. 1, to folio 13, col. 2, and Mazarine MS., pp. 50-55.

cranes are unable to take refuge in bodies of water, since the rains have not yet set in and the ground is dry.

In autumn, too, the days are clement and the weather is mild. Moreover, beginning with that season, there is a long period (until spring) when falconry can be readily practiced. If perchance a falcon is injured by a crane or incapacitated as a result of some other mishap and becomes unwilling to fly at cranes, the long flying season affords time to restore her to her former good condition or even to improve it. Furthermore, in the autumn young cranes remain with their parents, as they are still weak in flight and in self-defense, and the mother cranes provide for the preservation of their young ones. When she flies she regulates her speed to suit theirs. When they do not fly as fast as she does, she waits for them. This is the opportunity for the falcon, who is then able to overtake them.

Captive falcons have in the autumn, as a rule, just come from the mews, where they have completed their moult. They have rested during the summer and are therefore at their best. Sorefalcons (i.e., unmoulted birds) have their full plumage, uninjured by work. Those falcons that need it should have instruction with the train sufficiently early to be well educated and ready for entry to cranes when autumn comes.

Winter is not as good a season for hunting cranes as autumn, because, although many cranes are then resident in warm climates, the weather is damp (sometimes wet) and swamps are abundantly supplied with water, affording cranes an easy refuge and valuable defense. Since the ground is muddy and slimy, neither dogs and horses nor men can readily reach the falcon to assist her after she has captured a crane. Winter days are inclined to be windy and therefore not propitious for falconry. With the passing of autumn the days when our sport can be satisfactorily pursued are

fewer. If any accident or injury befall a falcon, there is hardly time to rectify the trouble. Moreover, young cranes are older and stronger than they were (in the autumn) and their mothers also have increased in strength as they have had a long rest. Falcons that have been kept idle and indoors have perforce suffered from smoke settling on their feathers, for at that time of year it is difficult to protect them from it and their feathers are in consequence defiled with soot² and lack the gloss³ that not only added to their beauty and brilliancy⁴ but served also to protect them from the rain. When smoke-laden and soiled feathers come in contact with heavy fog and rain, they easily become soaked with water and the falcon is thereby hindered in her flight.

If a falcon brings down a crane in winter when the ground and grass are wet, her feathers become damp, so that if her quarry escapes she rises again with difficulty to effect a recapture. For all these reasons, the colder the region in winter the less suited it is for hawking.

Of spring the same is true, although more cranes are then in evidence and they are still weak from the exertions of their long return journey. Further evidence of their spring debility is the following circumstance: In a certain flat district of Apulia called the *Capitanata*⁵ cranes captured by means of gerfalcons, falcons, and other birds of prey were found to have blood-soaked feathers and plumules beneath their wings and along their sides. They were so weak that it was with difficulty that they flew at all. Some of these birds were even taken by the hand of man, an occurrence I have heard reported in no other region. It is difficult to account for this

² *extractamentus*.

³ *florem*.

⁴ *quo pene erant mundiores et spendidiores* (i.e., *splendidiores*).

⁵ This is the great plain around Foggia that extends to the Adriatic on the Bay of Manfredonia, today a fertile, wheat-growing area.

phenomenon. It may be that the cranes had been fighting because the mating season was setting in; or the maternal cranes had been struggling to drive away their young, since they were looking forward to the raising of another family of nestlings; or, possibly, the cranes were so exhausted by their long and arduous flight that blood flowed from their nares and when they preened and anointed their plumage the latter became smeared and sticky with blood.⁶

Although such cranes are, as a rule, found scattered and solitary, having driven away their young ones, and although they and their young are both still weak, spring is even a poorer season than autumn for crane hunting, because the hawking season is short and if an injury is inflicted on the falcon, either by a crane or by some other agent, it cannot be repaired unless she is retired to the mews. When she comes out the time is too short to re-establish her as a hunter. In spring, also, since the winter is past and summer is approaching, falcons are less greedy and are not keen in flying at cranes. In addition, their mating season has arrived and they are more fastidious and less influenced by hunger.

Summer is entirely unsuited to crane hunting. Few of these birds are seen during this season; they are busy with their nest building and are generally to be found near difficult bodies of water and in swamps, which they seldom leave. The parents are in evidence, but few young cranes are seen; and the mothers are especially strong at this season. Falcons, on the other hand, because of the heat and since they are losing their feathers (the moulting season having begun) and the rest of their plumage is ragged, cannot exert much effort in hunting. They are awkward in flight and tire quickly in their contests with cranes, so that they are easily incapacitated.

⁶ Cf. Book I, chapter xxiii-B, p. 44, for an account of this same incident.

CHAPTER III

ON THE PROPER WEATHER FOR CRANE HAWKING

We have thus indicated the seasons favorable for hunting cranes in various regions. We must now discuss the varieties of weather that are either suitable or unsuitable for that sport.

All misty and foggy days must be strictly avoided, because then visibility is poor and the course of the falcon after a crane cannot be followed to furnish, if needed, the usual assistance. Rainy weather also moistens the falcon's plumage and hampers her flight. Snowy weather, at least while the snow is falling, is harmful, for it wets the falcon's feathers. Such weather is harsh and gloomy, so that one cannot see far. Bitter cold also reduces the falcon's flying spirit. So long as snow is on the ground, though it may not actually be an obstacle to flight, the falcon has no eagerness for hunting because she hates and fears the white mantle. If a falconer wishes to fly his bird at a crane where the ground is covered with snow, he must first call her to the lure, so that she may grow used to the snow and lose her fear of it.

Strong winds make bad flying weather, as they hamper the falcon. Gentle winds, however, provided climatic conditions offer no other inconveniences, are no obstacle to flying a falcon at a crane. In all such adverse weather, cranes remain out for short periods only and leave their feeding grounds early.

Dewy mornings, if the falcon takes a crane and brings it to earth while the dew is still on the grass, are unfavorable for the chase, because her feathers become wet with dew (which moistens them even more than rain) and she is unable to rise in pursuit if the crane escapes.

Sultry weather, added to the exertions of flight, overheats the falcon, with the result that she is soon fatigued.

Cloudy days that are quiet, without fog, rain, or snow, are good for hunting; for then cranes remain longer on their feeding grounds and return later to their watery resorts. In overcast weather a falcon can make more and better flights and does not become unduly heated by her exertions. Also the falconer can choose his ground at will where to slip his falcon, as he need pay no attention to the direction of the wind.

Clear, quiet days are best for falcons that are in condition to fly in the early morning; because the brightness of the day spurs them to successful flights. But cranes do not stay out long on bright days, and such weather is unsuited to falcons that do not fly well in the early morning either because of lack of practice or because they are not hungry. If on fine days one waits for the hour when birds that are unaccustomed to early flying are ready to hunt, the sun has risen so high that they cannot fly or exert themselves because of excessive heat. Also when one waits for those falcons that are not hungry to develop an appetite, the sun becomes too hot for them to fly. Moreover, the cranes will have deserted their feeding grounds, and if one wishes to get several flights during the day it is not possible. As stated, when the sun is high in the heavens the heat is intense and the cranes have already departed. Also one is obliged to use a new falcon for each flight.

CHAPTER IV

OF THE HOURS OF THE DAY WHEN GERFALCONS MAY BE FLOWN AT CRANES

We have now discussed the topic of weather conditions as well as the seasons suitable in various regions for hunting cranes. There remains only to review the hours of the day when cranes may be hunted to best advantage.

When weather conditions are good, falcons may profitably be flown at cranes in the morning from sunrise until the third hour, and in the afternoon after the ninth hour for the last three hours before sunset. On fine, clear days it may not be practicable to fly a falcon so late in the morning and it may be well to begin later in the afternoon in order to avoid great midday heat. The hours we have given refer principally to autumn and springtime. As winter approaches, falcons may be flown later in the morning and earlier in the afternoon. The colder the region, the longer in the morning and the earlier in the evening can flights be undertaken with success.

The forenoon is better than the evening hours for crane hunting, because in the morning the quarry remains longer in the fields. Indeed, they are busy at that time seeking food and are hungrier than later in the day. Their appetite is greater then because they have had a longer and more favorable period (during the night) to digest their previous evening meal than they have before evening for assimilating the food they eat in the morning. The interval between evening and the next morning is longer than that between the third and ninth hours of the same day. Another reason why the morning hours are better for pursuit of the crane than those of the afternoon is this: If the falcon is kept waiting to fly until the afternoon, one must decide whether or not to give her food in the morning. If she is fed at that time it is difficult to allow her just the amount of nourishment that will not dull her keenness before she is flown in the evening. If she is given too much she will evince no desire to hunt cranes; if she has too little she becomes weak, and she would be far from competent because of her long fast if she were not fed at all from the morning of one day until the evening of the next.

An additional reason for preferring early hours for the chase is that if a falcon is lost

in the morning she may be hunted with ease during the long daylight and the search for her is more likely to be successful. If she is lost in the evening, with night coming on, conditions are not favorable for finding the errant bird; to which may be added the further difficulty that the falcon who spends the night in the open and feeds out of doors is always hard to recover.

In general, the hours from nine in the morning until three in the afternoon are not propitious for flying falcons at cranes; for then the latter have left their feeding grounds and, if the day is clear, the heat is often intense and unbearable. The hunters lose their spirit and their appetite for the chase, while during those hours eagles and vultures (which the falcon fears) are on the wing, soaring in the air.

When it is not hot at midday and there are clouds in the sky, the falcon is much more alert than on a clear day, especially since on dull days the predatory eagles and vultures soar very high and do not circle about immediately overhead. In such weather, wherever the swamps (that usually furnish a midday refuge for cranes) have not sufficient water in them to thwart the falcon, she may be slipped at the prey. For the quarry, relying on watery ground for defense, tarries there, not expecting the attack of a falcon at that hour and place.

It is generally agreed that if there are cranes in a locality where it is unusual to fly falcons, although they are of a species that do not as a rule seek refuge in the places where falcons are flown (and have, moreover, been delayed here simply by the fortuitous circumstances of migration), and although time and locality make it possible to fly a falcon at this desirable quarry, it is nevertheless to be expected that the falcon will not be keen to capture her prey and will not fly well, because at these hours falcons are accustomed to rest.

CHAPTER V

OF THE DISTRICTS THAT ARE BEST SUITED FOR CRANE HAWKING

The weather conditions and hours of the day most likely to produce good results in crane hunting have just been discussed. Now let us see in what localities one is most likely to secure good flights. When a falconer goes out to hunt cranes he should not be content with merely locating the quarry; he should also take into account the topography of the district, for not all regions are favorable for his purpose. Land that is broken by ditches or channels, by watery or dry hollows, vineyards, hedges, and other enclosures is unsuitable. Although falcons have no fear of these obstructions, they prevent prompt assistance from reaching them when in trouble.

Regions covered with shallow but wide stretches of water, or that have many and dense thickets, much long grass, or willows, render a falcon timid. Moreover, while a man may possibly come to her assistance, a dog is useless in such surroundings. When a falcon brings down a crane in a thicket or in high grass and the quarry escapes, the latter with the aid of her long legs can easily rise from the ground; but it is more difficult for the falcon (with her short legs) to take flight after the crane.

Large rivers, deep water, groves, swamps, and canebrakes are additional obstructions feared by falcons and form impediments that neither man nor dog can overcome. Not only must care be taken not to fly a falcon in districts characterized by obstacles of this kind, but the falconer must avoid also the neighborhood of every asylum in which the crane may take refuge when pursued by the falcon. Even an area entirely free from these impediments will be useless for crane hunting if mingling with the cranes are geese, bustards, or other birds at which the falcon may check when slipped in pursuit of her legitimate quarry.

Regions preferable for crane hunting are wide, open plains or, as a second choice, low, hilly country that is free of the obstacles mentioned.

Hindrances to flights at cranes may be placed in three categories: In the first group are those that prevent the falcon from taking her quarry yet permit her to receive aid from men or dogs. In the second class are those barriers that not only prevent her from capturing her prey but preclude human and canine assistance. In the third group we place those obstacles that prevent help from reaching her after she has captured the crane. This last group is in every way the most serious to deal with; for when a falcon captures a crane where assistance cannot reach her, her quarry will tire her out, strike her, and inflict injuries that prevent her holding her prey, besides leaving her so exhausted and battered that on future occasions she will hesitate to fly at cranes for fear of further injury.

Obstacles that merely prevent a falcon from capturing her prey cause her no injury, nor do they make her afraid to attack a crane when flown again, because the crane has done her no harm.

Where there is an obstruction so great that neither man nor dog can reach the falcon, she should not be flown. This is true also when the impediments are so numerous that adequate assistance cannot be afforded her. If, however, the obstacle can be overcome by man and dog, then the falcon may be flown (in the manner we shall describe); but where there are many obstacles, any one of which may prevent aid reaching the falcon, she must positively not be flown.

There are certain types of ground in which a man may be of more timely assistance than a dog; such areas are those that are flinty or covered with high grasses, tall corn, and briars; but where there are ditches, hollows, and muddy ground a dog may run about more easily and more readily give aid.

Areas where either a man or a dog may bring help but where a falcon cannot capture her prey are those in which lie wide and shallow bodies of water. Here a man or a dog might reach a falcon in distress, but the falcon does not dare to attack.

The obstacles that prevent both men and dogs from assisting a falcon who has captured her quarry are excessively deep valleys, gullies, or rivers over which they cannot pass when a falcon has brought down her quarry on the other side or beyond them.

Where the water is very deep or the forests are thick, the falcon could not take the quarry; nor could she be helped by either man or dog were she to do so. If such adverse conditions are encountered, falcons must on no account be flown.

And, finally, wherever there are bustards, storks, geese, or other birds at which a falcon may check when flying in pursuit of a crane, she must not be slipped, for she will then desert the crane and go after the smaller and, to her, more desirable quarry. These outsiders must first be separated from the cranes, pursued, and driven from the neighborhood and the company of the cranes. To do this the falconer must ride between the birds he desires to drive off and the cranes. The horseman must go close to the unwanted birds to frighten and force them to take flight. If these birds are too near the cranes to be driven off without the latter, both groups should be evacuated, when, being of different species, they will separate as they rise into the air.

CHAPTER VI

OF THE NUMBER OF CRANES TO WHICH A NOVICE FALCON MAY BE ENTERED

The localities that are propitious as well as those that are unsuitable for flying falcons at cranes have been described. Now we must

determine at what number of cranes one may fly a falcon who is being entered for the first time to that quarry, for one should not fly a novice at an unlimited number of large birds. It is, indeed, desirable to begin with one crane only, although a solitary bird is difficult to find unless it be one that has been injured and so prevented from following the flock. One might try flights at two or three cranes. Four birds, however, are too many, and that number should not be attempted unless it is not possible to do better.

It is safer for a falcon to assail a group of two than one of three cranes, provided one of the two is a young one. It is less dangerous, as a rule, to attack the smaller group, since cranes assist each other against a common foe and the individual that is attacked receives less aid from the second crane of a group of two than from the two remaining in a set of three. However, when the choice lies between the group of three cranes (in which one is a young one) and a pair of birds (both adults), it is better tactics to fly the falcon at the larger group, because a young crane is so (comparatively) weak that a falcon is less hampered by the defense put up by this group of three than by two cranes neither of which is young. It is important to note that one adult crane captured by a falcon makes a stronger defense when aided by a second adult than does a captive young one assisted by two adults; for it is the captive adult that inflicts the more serious injuries on the falcon, attacking her with feet, beak, and wings. Assisting cranes can do no more than attempt to crush or trample¹ on the falcon.

Even when a falcon is immature and has never before flown at cranes and should not be expected to distinguish a young crane from an old one, nevertheless she recognizes a small and weak quarry, so that it frequently happens that she seizes a young crane and

not an adult. It is always preferable to choose a group of two rather than one of three cranes where one of each set is young or where they are all full-grown. Where there are more than three cranes present, conditions are less favorable.

A falcon must not be flown at two or three cranes standing near a large flock where they can take refuge among their neighbors; for she will not, as a rule, pursue them boldly. Should she do so and succeed in taking one, it would result in serious danger to herself. For many, if not all, of the other cranes would come to the assistance of their captured companion.

CHAPTER VII

ON THE EQUIPMENT SUITABLE FOR A FALCONER HUNTING CRANES

We have completed the discussion of practice with the train, of the proper weather, and of places best suited for flying at cranes. We have also explained the number of cranes to which one may properly enter a novice falcon. Now let us see what equipment a falconer requires when he goes out to practice the art of venery with the intention of hunting cranes with a gerfalcon.

The skirts of his garments must be short,¹ so that they do not hamper his movements, and of a single color, preferably beige or an earthen tint, and of such material as peasants wear; for such cloth may be exposed freely to the inclemency of the weather and to use in rough places. If when he goes out to hunt he wears fine clothes of various colors (that are easily distinguished), the birds he hopes to capture with the falcon will at once see him and will not tarry but will easily escape. He should wear a wide hat to make his face less visible to the cranes, who will, in consequence, be less frightened by his appearance.

¹ *pesundare.*

¹ *habeat pannos vestimentorum suorum curtos.*

It will serve also as a shield for the falcon from wind, rain, and sun. If necessary he should wear heavy leggings that are a protection to his legs and feet from water, thistles, thorns, and other injurious objects.

The falconer's horse should be gentle and stand quietly; and he must not gallop without permission of the rider. When the falconer drops the reins on the horse's neck (to perform some task for the falcon with his free hand), the animal must not increase his gait. He must be quick to obey and agile in turning right or left as desired. He must be swift and not frightened by unforeseen or unusual objects. He must not whinny when on duty, because that will drive away the birds. He should not be difficult to handle or hard-mouthed,² lest when he hurries to bring assistance he may trample on the falcon. His bridle and martingale should carry no small, ornamental bells³ whose sound may frighten the birds. That the falconer may mount and dismount with ease, the saddle should not be lower in the seat than at the cantle. To this part of the saddle there should be attached a large meat pouch,⁴ placed on the side opposite that on which the falcon is carried. In this a live pigeon or chicken or other bird may be placed on which the falcon can be fed should the necessity arise. This sack should hang down behind the rider's leg. The falconer should also bring with him a lure, and he should go out accompanied by a number of other horsemen. It is well for each of them to have a lure; and one or more good hounds, trained to aid the falcon, are desirable.

The gerfalcon should be carried without a leash. Only her jesses should hold her, especially if she has already learned to hunt and has not been trained merely with the lure. If some bird at which the falcon is to be flown

appears suddenly when she is restrained by a leash, before the latter can be removed the quarry will make off so that it will no longer be worth while slipping the falcon in pursuit.

CHAPTER VIII

ON HOW THE MOUNTED FALCONER SEPARATES TWO OR THREE CRANES FROM A FLOCK

When the falconer finds several cranes in a good location for flying the gerfalcon but near a large flock of cranes, a horseman without a falcon should ride between the main flock and the smaller group. He should go quietly as if intent on other business, but nearer the big flock, so that the latter collection will fly up and leave. If the smaller lot of two or three cranes is so near the major flock that he cannot pass between them, he must ride toward the larger group from the opposite side to make them rise and fly away, leaving behind the few it is desired to hunt. If the flock that has risen resettles near the group of two or three cranes, let him repeat the action, riding around them and making them rise as before. It frequently happens that a flock flies off leaving behind them two or three cranes that do not belong to their company.

When, however, two or three cranes cannot be found that are thus separated from others and a united flock is seen, the falconer should ride toward it at an even, gentle gait, approaching in a wide circle. If a few birds that are suitable for quarry fly off, he should mark where they alight and gradually ride away from the main flock, not altering his gait but riding in ever increasing circles until there is no fear of alarming the cranes he had previously approached. Were he to ride swiftly away, those still on the ground might also rise in flight. If the few that flew away have come

² *dure boce.*

³ *Non habeat frenum aut pectoralis cum nolis seu campanellis.*

⁴ *carneria.*

to earth in a suitable position, the falconer may now approach them to fly his falcon. When the main body flies away, leaving only a few on ground that is convenient for hunting, then the falconer may at once fly his ger-falcon at them without seeking a new position.

It often happens that the whole flock takes to the air and during their retreat some of them separate from the rest, since they do not belong to a united band. Among these latter there are generally some single birds that fly off by themselves. If it is still early when this occurs, that is, before the third hour (nine o'clock), and if it is not yet time for the cranes to return to their water resort, the falconer should follow the smallest group that is on suitable ground for hunting. Should the flock, on rising, continue to show a united front, the horseman must again put them up and separate them, if possible, into smaller groups. When this has been accomplished, the larger groups should be driven off before slipping the falcon at a suitable smaller one.

If several flocks are found in various places not far from each other in a district poor for flying, or even a few whose numbers are no obstacle to good flights, they should be driven from the unsuitable ground¹ to make them separate and pass on to an area better adapted for flying falcons.

This process of isolating the quarry is especially designed to aid the novice who is undergoing her first season of hunting cranes. When she has captured a number of large birds and has become adept in that art, she may be flown at a number of cranes. Even then it is best to choose a small group, for then less danger threatens her. In this way, too, fewer cranes are subjected to alarm and when found on another occasion they will be more likely to remain quietly in the fields.

¹ The Bologna Codex (fol. 93^v, col. 1) says *convenientibus*, but the sense demands that we follow the Valencia text (fol. 153), where the word is *inconvenientibus*.

CHAPTER IX

ON THE SIGNS THAT CRANES WILL REMAIN QUIET WHILE THE FALCON IS BEING SLIPPED

We have described the method of separating a crane (or cranes) from a flock at which it was not convenient to fly a falcon. Now let us see what the indications are that cranes will remain quiet while the falcon is being slipped.

In autumn or winter, cranes that are feeding and are separated from the flock, wandering here and there, now with the wind and now against it, their heads lowered, looking for food, and that do not draw close to each other on the approach of a man, or else [while walking] ruffle their feathers and plumes and preen themselves with their beaks—and even those that do not walk about but ruffle their feathers or anoint them, or that rouse—indicate by such actions that they will remain quietly on the ground.

In the spring in addition to these signs, one should look for others that are due to the approach of the mating season. At that time they call to one another, flap their wings (rising a little from the ground), pick up bits of litter and straw¹ with their beaks and toss them in the air; indeed they really play with each other. The more frequently these acts are exhibited the greater is the likelihood that the cranes indulging in them will remain quietly in place when they see the falconer approach.

When cranes that are walking about on their feeding grounds stop eating, come together, flatten their feathers, turn toward the wind, lift their heads and raise and extend their necks as if they wish to fly, it is evident that they will not wait for the falcon to be flown.

¹ *palaceum et festucam*, Bologna MS., fol. 93^v, col. 2, l. 36.

CHAPTER X

ON THE POSTING OF ASSISTANTS ON AN OPEN PLAIN FREE OF OBSTACLES, EITHER ON A QUIET DAY OR WHEN A BREEZE IS BLOWING

Now that we have determined what groups of cranes will remain quietly in the fields when one goes out to hunt and which ones will not, we must describe the course to be pursued when the falconer rides forth to practice his sport. He who goes crane hawking must have in mind four considerations that will affect the career of his falcons. These are the nature of the locality, the direction of the wind, the provision of dogs for co-operation in the hunt, and the nature of the aid he himself and his fellow falconers can bring to the falcon. The last-named assistance is indispensable because, though the crane, strong and dangerous, may inflict only a single wound on the falcon, that injury may prove to be a serious handicap.

Such forms of succor as we have already described, and others that might be provided, should be especially available on the first occasion that a falcon flies at cranes. It is of the utmost importance that no harm befall her on her initiation, otherwise she may be so terrified that she will be unwilling to fly at cranes a second time. A further reason for such special assistance is that she will find these wild cranes much stronger than those employed in the train.

As we have already pointed out, the district chosen for flights at cranes may be either a level plain or one interspersed by low hills. The weather may be either windy or without wind, and there must be men and dogs properly stationed to be of assistance to the falcon in overcoming and holding the crane, who is often strong and dangerous.¹

In this form of the chase, there must be at least four men in addition to the falconer,

or falconers, who are to fly their birds. If there are more, all the better. They must be mounted on fast horses, and each man should if possible be accompanied by a trained hound. It is absolutely necessary to have at least one dog; and any number up to four is desirable.

The falconer should first of all make himself familiar with the entire region in which he intends to go crane hawking. He should know whether it contains any of the obstructions or obstacles we have discussed, so that he may make suitable provision to meet or avoid them. Information concerning the region and its topography may be gathered from some one of his fellow falconers or from some inhabitant of the district. If he can get no reliable news from either of these sources, he should, before hunting, ride over the district himself and search for possible obstacles, so that he may acquaint himself with their nature as well as their position.

When cranes have been found and the falconer has become thoroughly informed in regard to that particular neighborhood, so that he is ready to ride out and fly his falcons, he should, in advance, send out his assistants and station them at a distance from the cranes in the following manner: One assistant must ride to the far side of the flock; a second must go to the right and a third to the left—all at the same distance from the cranes as the latter are from the falconer. Four men are thus placed about the cranes in the form of a cross. They must take up their posts in such a manner that neither their riding about the quarry nor their (motionless) presence alarms or causes the cranes to fly off. If there are more than four men (besides those who are to fly the falcons), the men should hide themselves at pre-established posts equidistant from each other, thus making an equilateral pentagon, or hexagon, if there are enough assistants for that purpose. Each one should be at the same distance from the cranes as the falconer.

An additional horseman should be sta-

¹ *dampnificans.*

tioned between the cranes and the man posted on the far side of the flock, away from where the falcon is to be flown and in the direction in which it is thought the crane will fly. This is done in case the freshly entered falcon, who has grown bold from her experience with the train, is disposed to capture one of the cranes at which she is slipped. If she has the courage to attack it, as she did the captive crane, and binds to it before it reaches the man on post who is farther off, the horseman placed nearer the flock will be ready to give immediate assistance. If two trained hounds have also been taken out he should be given one to send to the falcon's aid when he sees there is need. All the men who have been placed on guard (especially the one nearest the cranes) should stand so that they can see the birds without being seen by them, because if the cranes were to see the horsemen they would be frightened and fly away. Therefore these men must be hidden as much as possible.² If there are many more helpers than those we have mentioned they should place themselves farther away but in the same order. They are thus able to follow the falcon and give aid in case the first group of assistants is unable to do so because of the crane's rapid flight ahead of the falcon.

If the terrain where the cranes are found is flat and presents none of the obstacles that we have mentioned, and if there is no wind, all the posted assistants may stand at equal distances from the cranes. If the plain is entirely free from obstructions but there is wind, the watchers who are standing down wind from the cranes should be at about twice the distance that the rest are from the flock. That distance will vary according to the strength (or weakness) of the wind. When the falcon overtakes and strikes the crane still flying

² Although this sentence is tautological, it illustrates one of Frederick's devices for impressing the student with the great importance of the canon. There are, as the reader will notice, many such purposeful repetitions throughout the six books.

against the wind, the prey often turns about and flies with the wind, hoping to be helped by its force; indeed, the crane's large wings make easy a down-wind flight. Therefore, unless the assistant posted in that direction is farther away than the other men, he may be too late in bringing aid, since the crane passes quickly over the assistants and may injure the falcon before help can be given.

CHAPTER XI

OF POSTING ASSISTANTS ON A PLAIN WHERE THERE ARE IMPEDIMENTS TO THE HUNT, BOTH IN A BREEZE AND WHEN THE AIR IS QUIET

If where the cranes are feeding the plain has obstacles that nevertheless permit hawking, and if it is windy, the falconer must observe whether a serious obstruction is down wind or in the opposite direction from the cranes. If it is down wind, then the danger that the crane will fly that way is redoubled, because the wind carries the quarry in that direction and the obstacle acts as a refuge. Therefore a man must be sent thither to recover the falcon cautiously and quickly. When the obstacle is up wind, especially when the wind is strong, fewer precautions are required, as cranes wing their way with difficulty in an opposing wind. Still less care is required if the falcon is flying well and attacks boldly. However, unless the obstacle is near, a man should be placed there to lend assistance; because a crane is strong and swift in flight, she sometimes, for her own defense, flies against the wind to reach the obstacle that will impede the falcon. Again, if the barrier is so far away that the falcon is given an opportunity to take the crane before she reaches shelter, the assistant near the refuge will be unable to come to her aid. It is therefore necessary to place a second man closer to the point of departure and in such a position that he can assist the falcon in the intervening area.

If it is not possible to post a man at such an intermediate point, then two men should be posted at the barrier, one to run out and help the falcon, the other to remain near the refuge in case the crane and the pursuing falcon both reach it.

If the region is level and there is no wind but one or more of the aforementioned obstacles present themselves, certain precautions must be taken, to wit: When there are no additional men available beyond the four, five, or six that are stationed around the cranes, one of these (i.e., the assistant on the side of the flock nearest the obstacle) should take up a position farther from the cranes than the rest of the men but closer to the barrier. Now, if the crane flees toward it, the assistant can give aid before the crane has had time to inflict any injury on the falcon. However, when a number of men are present in addition to those stationed around the flock, send someone to post a few men, or many, depending upon its size and extent, near the obstruction. These men should study the nature of the impediment so as to cover it and give prompt assistance if and when necessary. When the barrier is such that a hound can be of more effective aid than a man, a number of the former should be dispatched. When, however, men are likely to be more useful, more men than dogs should be utilized and the latter sent where they can best be of use. One should keep in mind the curious fact that cranes will seek a given refuge when there is no wind but will avoid it when there is a strong breeze blowing from it toward the flock.

CHAPTER XII

ON POSTING ASSISTANTS ON A HILLSIDE UNDER VARIOUS CONDITIONS OF WIND AND TERRAIN

If the terrain where the cranes are found is sloping, without obstacles, and windless, the man stationed downhill from the cranes

should be posted much farther away than those that are in place toward the top of the hill, because cranes are heavy, massive birds and seek shelter preferably low down in the valley. They do not rise easily and therefore fly more swiftly downhill than up.

Whether or not there is wind in a hilly region that presents hazards, a large number of assistants should always be sent downhill when there is an obstruction in the direction of a valley. If the obstacle is toward the hilltop, there is no need (for the reasons already stated) to send many men to give aid in that direction.

In windy weather and on a hillside, with a stiff breeze blowing toward the valley, the men stationed downhill should halt very much farther from the flock than when the air is quiet. The reason for this is that the crane, escaping in that direction, has the double advantage of wind and slope. If the cranes are near a hilltop, it is always well to place a man leading a hound on the far side of the hill just below its margin, because the first hound that follows the crane may lose sight of it through the interposition of the hill. As the crane, fleeing from the falcon, crosses the summit, the man stationed on the opposite slope can release the hound he has with him to follow and assist the falcon, or he can at least take part himself in the chase (even without a dog) to give such aid as he finds necessary.

CHAPTER XIII

ON THE POSITION OF THE FALCONER IN A BREEZE ON A PLAIN WITHOUT OBSTACLES

In a windy, level region without obstructions, the falconer who is about to slip his falcon, after approaching the cranes in a circuitous manner, should be careful in taking up his position that the wind is blowing across the flock into the face of the falcon. As he

makes his circuit, the wind may blow in turn from his right, left, back, and front. He should, in consequence of this, carry the falcon on the hand requiring the least maneuvering so as to bring her into position to be slipped into the wind when she is flown at the cranes.

Flying a falcon against the wind has many advantages. It is well known that the wind is not as great a hindrance to the falcon as it is to the crane. Her wings and body are smaller than the crane's and offer less resistance to a head wind, but when a falcon is slipped with the wind its force against her back is a detriment. Moreover, when a falcon is launched at cranes into the wind, the quarry is at a disadvantage, because the prey flies more slowly against wind than with it, thus making it possible for both men and dogs to bring prompt help to the falcon. And again, when a falcon that is directed into the wind pursues and attacks a crane, the latter, in its efforts to escape, may turn and fly down wind. In doing so it travels back toward the falconer and the men accompanying him, as well as toward the assistants posted down wind, all of whom are available to succor the falcon.

Were a falcon released to fly with the wind, the crane (which has large wings that add to its speed in flying down wind) would be able to outdistance both men and hounds, with the result that if the falcon finally seizes it she will do so at such a great distance from possible help that she may be severely wounded by her quarry. When a crane starts to fly down wind it rarely turns around to fly up wind again, even though the falcon pursuing it attacks and strikes.

CHAPTER XIV

ON THE POST OF THE FALCONER IN A BREEZE ON A PLAIN WITH OBSTACLES

When the region chosen for sport is level but is windy and presents hazards, the latter

may be directly up or down wind in relation to the cranes, or they may be to one side. If the obstructions are up wind, the falcon should be slipped across the path of the breeze, so that she may prevent the cranes from taking refuge in that direction. Also the falconer on horseback and flying the falcon should promptly ride and post himself between the cranes and their possible refuge. If the hazard is down wind, the falconer must stand (or ride) between it and the flock, and slip his falcon into the wind. When the obstacle is to one side of the cranes, the falconer must place himself between it and the flock and then fly the falcon into the wind. When this is done the obstacle lies at her back and the cranes will fly in the opposite direction. In flying the falcon from a position to one side of the cranes (with reference to the wind), care must be taken to launch her with the hand well into the wind, irrespective of the position of the cranes, because it is the habit of birds of prey to rise against the wind. If the falcon is slipped in any other manner, her subsequent flight is sure to be impeded by the bad start she has been given.

CHAPTER XV

ON THE POSITION OF THE FALCONER ON A HILLSIDE THAT PRESENTS NO OBSTACLES, ON EITHER A WINDY OR A QUIET DAY

When cranes are on a hillside and there are no obstacles and no wind, the falcon must be slipped from such a position that the quarry is downhill from the falconer, who, if necessary, must climb the hill to attain a post above the flock. Not only is it easy for a falcon to fly downward from an elevation but, though the cranes may rise high to escape, the falcon can easily overtake them when she is flown from higher ground.

When cranes are on a hillside without hazards but with a wind coming across the hill

down into the valley, the falconer must ride to one side of the cranes and slip the falcon from that point. Should he stand between the cranes and the hilltop, although he would be slipping the falcon downhill, it would be a false move, since the wind would be at her back; and were he to stand below the cranes and let her fly into the wind (which is good in itself), he would be flying her uphill. Therefore it is better to stand to one side, because then she flies neither directly with the wind nor against the hill.

When a breeze blows from the valley toward the hill, the falcon must be slipped from a position uphill from the cranes, thus giving her a double advantage, as she flies both into the wind and downhill. When the path of the wind is along the hillside, the falconer and his bird should ride with the wind along the hill until he reaches a position beyond and a little higher than the cranes. The falcon is now flown from a position in which she enjoys the same advantages as before.

CHAPTER XVI

ON THE POSITION OF THE FALCONER ON A HILLSIDE WITH OBSTACLES AND ON EITHER A WINDY OR A QUIET DAY

Should the hillside present a hazard but there is no wind blowing, and if the obstruction is downhill from the cranes, the falconer should take up such a position that the falcon when flown is not directed against the hill and yet the impediment lies as much as possible at his back. In every other delivery from obstacles the falconer should take up a position that will place them as much as possible behind him.

When the slope where the cranes are feeding is windy and also presents an obstruction, if the latter is downhill and the cranes are directly between it and the hilltop, three vari-

ations of the situation may present themselves: In the first the wind may blow from the hill, in the second instance toward it, or (third) from either side. If the obstacle is uphill, directly above the cranes, the same problems arise; i.e., the wind may come either over the hill across the obstacle toward the cranes or in the opposite direction, or it may blow from the side. When the hazard lies to one side of the cranes and on the same level (neither higher nor lower), one of four possible problems presents itself for solution. The wind may blow along the hill from the cranes toward the obstacle or in the opposite direction; it may blow toward the hillside or away from it—in both instances across a line from the cranes to the obstruction.

When the hazard is on the hill directly above the cranes and the wind is blowing toward the hilltop, the falconer must climb above the cranes, and, keeping the hazard at his back, fly the falcon downhill into the wind. This can be done if there is sufficient space to slip the bird between the obstacle and the flock of cranes. If not, the falcon must be directed from the side but in such a manner that the obstacle still remains as much as possible behind the falconer.

If the obstacle is on the same level and to one side of the cranes, with the wind coming toward it from the direction of the cranes, the falconer must place himself between them, with his back directly toward the obstacle, and slip the falcon into the wind. In all other cases the falcon must be slipped from such a position that any hazard lies either entirely behind her or is at least as much as possible to one side.¹

Under all these circumstances the sportsman should avoid launching a falcon with the wind. She may be tossed into it or, at least, across it. The stronger the breeze the more care the falconer must take not to slip his falcon directly with it.

¹ That is, not directly in front of the falcon.

CHAPTER XVII

ON CERTAIN PRECAUTIONS TO BE
OBSERVED IN SLIPPING A GERFALCON
AT CRANES; ALSO ON THE
USE OF HOUNDS

After the assistants have taken up their positions around the cranes, the falconer, carrying his gerfalcon, may approach the quarry in order to slip her; but he must neither go too near nor allow the novice falcon to fly, if there is a strong wind or if there are obstacles, lest some accident befall the untrained bird; nor should he slip the falcon before the assistants have arrived at their designated posts.

The falconer should not ride out to fly his bird with more men than he needs. If he has no captive live cranes, but a dead one that has been captured by some falcon already expert in crane hunting or taken in some other fashion, let him carry it with him to feed the novice falcon should she fail to capture the crane at which she is flown. He should, also, have with him a lure and the best meat available, and one or, if possible, two assisting dogs. If a dog is unable to pick out the quarry that the falcon has chosen (when she is flown at several cranes standing close together), the second hound may be able to do so; or if one of the dogs has a bad fall or a thicket blocks his passage, or if there is some other barrier to his giving assistance, the other animal will be able to reach the falcon. Sometimes when two falcons are slipped together at a flock of cranes it happens that one falcon pursues one crane while the other follows the second bird. Then, while one hound is assisting the first falcon, the remaining dog can go to the aid of the second. In case both dogs go to the help of the same falcon and one of them shows a desire to worry the crane or to carry it off, the second will be able to hold it down and thus prevent the first dog from shaking it too vigorously or carrying it away. If more cranes come to the assistance of the bird that

is being held by the falcon and one dog, the second dog can seize at least one of the rescuing cranes.

CHAPTER XVIII

ON ENCIRCLING THE CRANES ON
HORSEBACK BEFORE SLIPPING
THE FALCON

A falconer should not ride directly at the cranes; he should encircle them at a distance, approaching gradually in a spiral. He must also keep constant watch to see whether or not the quarry show signs of remaining where they are. By these indications he should be able to judge how quickly he may approach the birds, meantime reducing his encircling movements. He should not prepare to slip the falcon until he is sure from their behavior that the cranes will stay quietly in the field and that immediately upon the flying of the falcon they will not rise at such a distance as to frustrate the latter or cause some accident to befall her.

Even though a falconer judges from observation that the moment is auspicious (and he has reached a proper position) for slipping the falcon, he should not do so if he sees that one or all the cranes are gazing in his direction. Were they to see the falcon leave the fist, they would at once fly off. She should be slipped only when the heads of all the cranes are bent to the ground or at least when none of them are looking in the direction of the falconer, for they are then more likely to remain quiet.

During the time that the falconer is encircling the cranes, preparing to slip his falcon, and while he is in the act of throwing her from the fist, both he and those riding with him should preserve a uniform gait. They should all ride one behind the other with no spaces between; nor must any one of them pause on the way, because any irregularity in

their progress may cause the cranes to rise. Let us repeat: There must be no quickening or slowing down of pace and no delays, for frequently this uneven progress disturbs the cranes and causes them to take alarm, rise, and fly away.

In completing the spiral of approach the horsemen should ride so as to reach a point whence the falcon may be slipped in such a direction that she will receive the best possible assistance from both men and dogs. Also, during the encirclement, if the falcon is one who has not been broken to the hood, the carrier should keep his body between her and the cranes, so that she may not see them and be made restless and so be induced to bate toward them. Let him give her a tiring and continue to shelter her with his body. The tiring should be taken from her long enough before she is slipped to give her time to relax her hold on the carrier's fist, for she takes a firm grip of the hand on account of the tiring and her hungry preoccupation with it. She must be allowed also an opportunity to shake herself, to defecate if she wishes, and in general to prepare herself for flying. The point at which she is to leave the fist should not be farther from the cranes than the distance she has been accustomed to fly to the train; and the nearer the falconer can come to the cranes without making them fly off (because of his presence, or on the slipping of the falcon), the better the results will be.

There are certain signs that the falcon is ready to fly at the cranes. When the quarry is shown to her, she flattens her feathers, fixes her gaze upon them (*exacuit visu*), beats her wings or bates, shakes herself, and, if need be, defecates. If possible she must be slipped and even launched from the hand with force before she bates, for when she is flown after much bating she loses her keenness, mainly because fatigue has weakened her flight.

If the falcon wears a hood, it should not be removed until she is near the place whence

she is to be flown but yet in time for her to shake her feathers, to defecate, and, in general, prepare to fly. If the removal of the hood is delayed until the place is reached for flying the falcon, that point will be passed before the falcon has performed these preparatory acts, since no stop or slowing up is allowable while she is performing them or while she is slipped. When the hood has been removed, therefore, and the falcon has been allowed time to prepare herself for flight and she shows a desire to fly at the cranes, she should be slipped from the fist with an assisting motion of the supporting arm.

When a novice falcon has just been entered to cranes, the hounds must not be released at once, for they may cause the quarry to rise too soon for the falcon's convenience. It is possible, also, that they may frighten the falcon by running beneath her, especially if she is naturally afraid of dogs, all of which may make her less eager to fly at the cranes.

CHAPTER XIX

ON THE NATURE OF THE ASSISTANCE TO BE GIVEN A GERFALCON WHEN FLYING AT CRANES

After the falcon has been slipped and the dogs released ready to go to her assistance, the falconer should not change the gait of his horse nor ride toward the cranes until he has seen how they will behave. If the flock remains quiet and does not rise until the falcon is near it, and then takes to the air, the falconer who slipped his bird should ride to her assistance. But if the cranes remain on the ground and do not rise even on the approach of the falcon or the dogs, he should ride swiftly at the cranes (without calling out, however, lest the falcon think she is being called to the lure) and put them up well into the air before the falcon discovers them on the ground. Should the falcon find them waiting in the field and not yet risen from

the earth, she might, in attempting to strike one of them, herself hit the ground with all her force, an experience fraught with danger of serious injury. She may, as a consequence, be unable to rise (or may rise only with difficulty) to pursue and attack the crane; or some other accident may befall her of so grave a character that she may even remain lying on the ground.

As soon as the cranes, fleeing from the falcon, fly toward one of the posted assistants, he should not continue to stand and wait but should gallop as quickly as possible in the direction whither all the cranes are flying, pursued by the falcon. But if she selects one crane and separates it from the others (in order to attack it), the assistant must observe in what direction that particular crane is fleeing so that he may, if need be, quickly succor the falcon. Were he to stand still until the cranes (or crane) that the falcon is pursuing have passed his post of observation, they would soon be so far away as to make it impossible for him to aid the falcon in the proper manner. He must also release the dog, if he has one, and encourage it to run with him to the falcon's assistance.

CHAPTER XX

ON THE GERFALCON THAT BINDS TO HER QUARRY

When a falcon flies at cranes, various eventualities are possible. She may seize her chosen quarry, or it may escape. If she binds to it, she may not be able to hold it. In case she is able to retain her grasp of the crane, the assistant galloping to her assistance should not ride directly at her but should approach to one side. If the rider goes directly to her he may not be able to check the headlong rush of his horse, which might trample and crush the falcon under foot.¹ When he has come near enough he should dismount and run to

¹ *pesundare et suppedicare falconem.*

the falcon. If the dog has hold of the crane he must remove him, not by threats, but with praise. He should then seize both legs of the crane, bind them together, extend them along the ground backward, and place a foot on them. Also, the crane's beak must be forced into the earth up to the eyes. Its breast is then exposed. The falconer must now hold the crane's wings with his hands and allow the falcon standing on her quarry to deplume it. Next the falconer must open the *gastraeum* of the crane below the breast, where the abdomen (*ovaria*) begins, and, inserting his hand as far as the *furculum*, extract the organ within that moves of itself, i.e., the heart, which even after its removal continues to pulsate in its normal fashion, dilating and contracting. This organ should now be given to the falcon to feed upon while sitting on the crane. Then let the falconer open the breast of the crane with his knife sufficiently to permit the falcon to feed upon it. The heart is extracted and given to the falcon first because the crane dies more rapidly after this act than from any other internal operation. And it may be added that while the crane is alive there is danger that it will wound the falcon. Moreover, were she to feed on the heart before it is removed from the body she would be soiled by the blood that gushes out and spurts into the air.

The falcon should be allowed to consume the same amount of food from the crane's breast as she is accustomed to receive on the train. The following day she must rest, and on the third day be flown again to the train. In this way she will take a crane without injury to herself, and is fed enough so that the next day (the fourth) her weight may again be somewhat reduced and she may be flown to free-flying cranes on the subsequent day. If the falcon has been much fatigued or injured by struggling with a crane, feed her less than usual, since a tired or wounded bird can then digest only a smaller quantity of food.



PLATE 109.—Casting off the falcon. A Ridinger print representing the sport in the Middle Ages



PLATE 110.—Two lateral panels of the Great Fountain in Perugia, whose reliefs by Nicolo and Giovanni of Pisa and Annolfo di Cambio represent the months of the year and the signs of the zodiac

CHAPTER XXI

ON THE GERFALCON UNABLE TO
BIND TO HER PREY, AND ON
THE PROPER TREATMENT
OF THAT CONDITION

There are some nonrapacious birds that in times of trouble receive help from others of their own species. The cranes are among these, as well as geese, crows, and ravens. Others, including doves, pheasants, and partridges, will not assist a captured fellow, nor mob a bird of prey when it attacks one of their species.

When a falcon takes a crane but is unable to hold it, this plight is the result of some unfavorable aspect of the locality where she brought it to earth, or because of the crane's strength or of the assistance given the captured crane by others of its species; or it may be that the falcon is too fat and therefore does not wish to fight her quarry (to retain it in her grasp) or, perhaps, help does not reach her in time. A further possible factor is the appearance overhead of eagles.

If the falcon is unable to hold the crane because of a defect of the terrain, the falconer should at once come to her aid and, if he is carrying a live crane of some sort with him, he should stretch it on the ground and hold it before the falcon in the manner previously demonstrated and allow her to kill and deplume the captive bird. Then, if its flesh is good, she should be permitted to feed upon it. But if the crane's meat is not wholesome, she should be fed, as she was on the train, with good food placed surreptitiously under the crane's wing. As we have already explained, the crane's flesh may be regarded as good if, when the heart is removed, there is fat over the auricles. If the falconer has no crane at hand he should approach the falcon where she is sitting, take the lure,¹ and (holding it with its back upward) show it to the falcon. He must neither call out nor throw the lure but hold it close to his body, so that

she will believe it to be a crane and not see that it is merely a bait. He must allow her to climb upon the lure, having first removed the meat (if there was any tied to it). While the falcon is sitting on the lure, she should be allowed to deplume it. Afterward the falconer should take the best meat he has and, holding the food, insert it from beneath the lure up between the wings and so feed the falcon without showing his hand.

If the falcon does not settle down after the crane has escaped but either circles about or flies toward the falconer, the latter should gallop in her direction and, when he is below her, dismount, and, without giving any call or throwing her the lure, hold the latter out in his hand as if it were a crane, draw it along the ground, and perform such other maneuvers as we have previously explained. If he has a live crane of any sort, he should do the same with it, holding its feet on the ground with his left hand and its beak with the right. Its back must be turned up so that it cannot injure the falcon with its talons. The falcon should now be allowed to feed on this crane, as on the others, and then be permitted to rest for a few days according to the amount of work she has done while hunting.

If the crane is very strong the falcon may be unable to hold it, either because of the wounds she has received from her quarry or for some other reason. If the falcon is unharmed in her struggle, she must be treated as we have advised. If she is wounded she should also be managed as already directed; but in addition she must be allowed to rest until her wounds are healed and she has gained flesh through extra feeding, indeed, until she has recovered her health. Then her weight may once more be reduced. She must also remain quiet, not only to regain her health but that she may forget her injuries. When she is quite well again, she is to be starved a little to increase her appetite and keenness in hunt-

¹ One made, presumably, of crane's wings.

ing the crane. This renewed eagerness will make her forget any harm that may have befallen her in the past.

When it is because of her fleshy condition that the falcon is unable to bind to the crane, or is unwilling to struggle in order to hold it, this will be evident in her failure either to attack or to strike with vigor. It may be that, having seized and brought her prey to earth, she makes no effort to retain it, and then when it has escaped she fails to follow it. All that is required in the case of such a falcon is to starve her further and thus to increase her keenness in attacking and striking and her perseverance in holding her prey. The falconer may discover by tactile examination whether or not the bodily state of his bird is what it should be.

Whenever timely assistance is lacking and the quarry has escaped, the falcon should be treated in the same way as when the crane's strength is too much for her, taking into consideration whether or not the falcon has been injured. On another occasion care must be taken that men are posted in such a way that the crane will not again escape through lack of punctual assistance. These assisting falconers must be placed at longer or shorter intervals, as experience shows to be desirable.

We attribute the falcon's inability to hold the crane to lack of assistance whenever the falcon struggles so long with her quarry that help might easily have reached her yet has failed to do so; and we place the blame on the crane's strength when the falcon struggles with her quarry but does not hold it for a period reasonably long enough for the needed help to arrive. Often it is because she is too fat that a falcon does not hold her prey. Then she usually circles about and returns to the falconer. When he notices that her return is becoming a habit and is induced by her desire to be fed by him, he must not at once show her the lure, nor feed her, but must wait a little before giving her food, so that she will follow the crane more persistently.

CHAPTER XXII

ON THE REASONS FOR A FALCON'S INABILITY TO BIND TO HER QUARRY AND ON THE METHODS USED TO CORRECT THESE DEFECTS

There are numerous reasons why the falcon may fail to capture the crane she is pursuing: (1) that she was not given sufficient practice with the train; (2) that she is too fat, or (3) too thin; (4) that she was frightened by eagles or vultures; or (5) she may abandon pursuit of the crane for that of other birds (an act called checking);¹ and, finally, (6) the quarry may have eluded her through effective and clever maneuvers.

The indications that she fails to take her quarry through lack of sufficient train practice are that, although she is not too fat, she does not strike at the quarry, or else she attacks and strikes with little enthusiasm. Unless such a falcon is flying at cranes as one of a cast, nothing remains to be done but to give her further practice with the train, beginning at the point where her education was defective and perfecting those stages that were incomplete or entirely lacking until she takes a crane eagerly and boldly. However, if she can be flown in a cast there is no need to put her back to the train. In that case she should be flown with a make-falcon trained and expert in the art of capturing cranes in the manner to be described later. The novice watches the expert capture a crane, then assists in the process, and, finally, becomes accustomed to taking one alone.

Whenever a falcon fails to seize a crane because she is overconditioned, she must be reduced by hunger until she pursues her prey in a bolder spirit and with eagerness. If she has been thoroughly exercised with the train and is still unwilling to take a crane, in the manner usual with those falcons that have been

¹ *Concambium*, "an exchange."

properly educated, it is then apparent that the cause of her failure is her excess flesh.

If the cause of her failure is that she has been too much reduced in weight, she should first be made somewhat more fleshy than is proper for flying; then her food should be restricted for a day or two to make her hungry but not weak. That a falcon is too thin may be recognized by these signs: After she has left the fist her tail hangs down, her wings move slowly, and she does not fly in her accustomed fashion. Even though she may move her wings rapidly, she does not fly as swiftly as usual and is therefore unable to overtake a crane. And when by a great effort she does overtake a crane and attack it, she has, nevertheless, scarcely sufficient strength to subdue it in battle and to retain her hold, because of weakness induced by starvation. Should she succeed in bringing her quarry to earth but it escapes, she is still not strong enough to rise and pursue it, although she flutters her wings and attempts to take to the air. Even though she succeeds in this first effort she will not again be able to overtake her prey.

When a falcon has been unable to seize her quarry through fear of eagles, vultures, or other large birds of prey circling overhead, care must be taken not to fly her again in a region where such rapacious birds are frequently seen nor at the hours of the day when they are on the wing. When it is fear of an eagle or other bird of prey that prevents a falcon taking a crane, she will shake her tail and turn from her course while in pursuit of the crane. Some falcons, under these circumstances, spread their tails and circle about, while others flee to some place of refuge.

When a falcon fails to capture a crane because she has checked at another bird, she may or may not take this second bird. If she does make a capture and her victim is a bustard, a white or black stork, or any species of heron, she may be allowed to feed on it as on

the crane, for these big birds are not found in great numbers. Storks and herons are not only large, like bustards, but their manner of flight resembles that of the crane. If the bird the falcon has improperly taken in place of a crane is a species of goose, or is smaller than a goose, the falcon must not be fed on this prey, nor on any bird resembling it; for there are many such birds in the fields and they differ greatly from cranes in both size and shape. Nor should the falcon, in the latter case, be fed at once, but her meal ought to be delayed. Even if she did not capture the smaller quarry at which she checked, when she is recalled to the lure she must not be fed immediately unless the falconer has with him a crane, upon which she may be allowed to eat.

On the other hand, if the falcon fails to capture a quarry of a large species at which she has checked and on which it is permissible for her to feed when she is successful, the falconer should dismount, take up the falcon on the lure, and feed her in the manner adopted when the escaped quarry is a crane. But if the quarry is of the small variety which a falcon should not be allowed to feed upon when she captures it, the falconer (still on horseback) must call her to the lure but not feed her.

We have ourselves witnessed such craft and shrewdness in cranes that one might believe them to possess reasoning powers. For example, after we had slipped a gerfalcon at them and she had separated one of the birds from the flock and was in pursuit, her quarry, happening to see vultures standing in a field, took refuge among them and so gained sanctuary, because the gerfalcon would not then dare to attack the crane. It seemed as if the crane knew the falcon would think the vultures were eagles that she would not have the courage to approach.

It is better that a falcon should fail in her first attempt to take a crane than to succeed and be wounded. For if she fails at first, the

reason will be apparent and the falconer will know how to remedy the defect. The falcon will now be keener for the prey on the second occasion than if she had captured her quarry and been injured or exhausted from fatigue. This is true whether or not she overcame and held the prey.

When the falconer has once entered his gerfalcon to cranes he must not allow many days to intervene between flights, because with the passage of time she may lose her desire to fly at cranes. The best results are obtained if she is flown at the most every other day.²

CHAPTER XXIII

ON ENTERING THE GERFALCON TO FLY SINGLY AT CRANES; AND OF THE USE OF A MAKE-HAWK

So far we have discussed the novice falcon that is undergoing training for hunting cranes, and is found to be unwilling to fly in a cast. We have in this connection explained the various exercises with the train and other steps requisite for her education. We must likewise consider the falcon that is to hunt alone even though she be willing to fly double.

Those falcons that will fly with a second (assisting) falcon require less initial practice with the train whenever there are few cranes available for the purpose. If cranes are to be had in large numbers, it is best to complete the exercises with the train in every detail—as we have described them. Instruction with the train is adequate, however, when the falcon has been flown to a train provided with a crane that runs and flaps its wings. The subsequent steps are more difficult to teach her to perform alone. Therefore, when some experienced crane-hunting falcon is to be had that can be trusted to capture her quarry and will fly well in a cast, one should proceed as follows the first time the novice is to be en-

tered to cranes: Two falconers go forth together, one carrying the initiate and the other the expert hunter. The make-falcon is now loosed, and when it is seen that she is giving chase to a crane and it cannot escape (the rest of the flock having made off) then the young falcon also is slipped, so that she may be present at the capture of the crane or at least see it seized as a crane should be caught. At this juncture either those men who are flying the falcon or those who are present to give assistance should gallop up, and he who arrives first should, if both falcons are standing on the body of the crane, place something between them so that they cannot see each other. The make-falcon must be given the heart of the captured crane, and lifted from the quarry as gently as possible. The education of the novice as she sits on the crane is then continued. If the make-falcon so employed is not broken to the hood, the falconer keeps his body between her and the crane; but if she can be hooded, this is done after she has eaten the crane's heart. The novice is then allowed to feed upon the crane as if she herself had captured it. When she has finished, she is taken up and the make-falcon is replaced upon the crane and allowed to complete her repast.

If the make-falcon employed is a very courageous one and habitually captures her quarry quickly, the two falconers must ride out together and he who carries the make-falcon should slip her as before. On the first occasion the novice was not permitted to fly until it was seen that the crane was in such a position that it could not escape. If it was evident on the first trial that the novice followed the other falcon eagerly, on this second flight she may be released sooner, that is, as soon as the make-falcon has singled out one of the cranes and is in pursuit of it. The novice is flown sooner than before because she has demonstrated her ability to follow the leader. On the next occasion the young falcon may be set free as soon as her more experienced com-

² *de tercio in tercium diem.*

panion has covered half the distance to the flock of cranes. When it is seen not only that she is thoroughly intent upon capturing the crane (and attacks and strikes courageously and with all her might), and that no harm has befallen her, also that she has on several occasions seized cranes in her talons before the make-falcon has come to her help, or that she has even once or twice separated a crane from the flock and captured it herself, then she is ready to be flown alone.

When, however, the make-falcon is not a bold hunter and does not capture her prey swiftly, but is rather one whose attack is slow and timid, i.e., one that follows her quarry for some time before capturing it, then a different plan must be adopted when flying her with a novice. In the first place, the two falconers should not ride together, but the one carrying the young falcon must go ahead to a point toward which (owing to the lay of the land and the state of the weather) it is thought the crane will fly. There he remains concealed, so that the crane will not change its line of flight at the sight of him. The make-falcon is now slipped in the chosen direction—namely, toward the man in hiding. When the old falcon has cut out a crane and is giving chase, the hidden falconer must release the young novice, not in a direct line with their flight but from the side. If she were flown at close quarters directly at the crane,¹ she might become alarmed or she might easily be injured by the quarry. Moreover, she prefers to make her attack from behind. These maneuvers may be repeated for several days until it is perceived that the novice follows the crane from a distance and gives assistance to her companion. From then on the two fal-

coners may ride together to fly their birds in the same manner as when they have a make-falcon that effects a swift and bold capture of her quarry.

We have now shown how a novice is flown in a cast with an experienced falcon and is taught by her, and how the falconer who carries the make-falcon precedes the second bird and slips his hunter sufficiently in advance for her to separate one crane from the flock; also how the second falconer comes up and, when he sees a crane has been isolated, slips his novice to follow the expert crane falcon so that they may both fly at the same quarry.² If this order of releasing the falcons were not followed but they were flown simultaneously, one falcon might cut out one crane from the flock and her companion choose a second. This would not be to our purpose, as the novice would then receive no assistance from the make-falcon and might be injured. The more cranes there are in the flock the greater the delay should be before the novice is flown after her companion, because it is more difficult for a young falcon to understand that a particular crane has been specially selected by the make-falcon when there are a large number in the flock. Moreover, it takes longer for the older falcon to separate a crane from a large flock than from a small one. This delay is also desirable³ lest perchance the young falcon be so eager to hunt that she is unwilling to follow the make-falcon but attacks a crane on her own account, not waiting for one to be selected by the more experienced bird.

Should a solitary crane be discovered—an unusual event—when both falcons are to be flown, the make-falcon should be slipped first and a very little later the younger bird. Although under these circumstances the falcons cannot each follow its own particular quarry,

¹ At this point in the Bologna MS. (folio 100, bottom of column 2) some words are missing. On page 404 of the Mazarine text the following words have been supplied: *forte timeret de ea ille posset ei defacili nocere et falconem, nam est libentius sequi avem a posteriori*. The same words are found in the Valencia text, fol. 164.

² This last sentence, from folio 100^v, col. 1, of the Bologna MS., is somewhat defective.

³ The translators have taken the liberty of transferring this sentence from its original position, i.e., after the next paragraph.

the hunters must not be slipped simultaneously; nor should the novice be allowed to start so soon after the make-falcon that they are so close in flight that one of the cast is seized with an overwhelming desire to attack the other.

CHAPTER XXIV

ON ENTERING TWO NOVICES SIMULTANEOUSLY TO CRANES

If no falcon experienced in crane hunting is to be had and two or more falcons are to be flown who have demonstrated that they can be flown in a cast¹ but have not yet been separately entered to cranes,² each of them must be instructed by aid of the train in the manner identical with that advised in the case of falcons destined to fly alone to cranes. When a number of these inexperienced birds have been trained in this fashion, the two that fly most courageously to the train should be selected and flown in concert at a free-flying crane in the following manner: After assistants have been posted in the prescribed manner, the keener flyer of the two is first slipped at the flock; then the other is flown (just as in the case of the make-falcon and the novice), in the manner advised when one crane only is found but two falcons are flown.

If there are two or more cranes, the bolder of the two falcons should be slipped a sufficient length of time ahead of the other to enable the leading falcon to reach a point midway between her starting point and the stance of cranes before the second is let loose. The latter will thus be unable to overtake her companion before she has separated a crane from the flock. If the falcons were slipped one immediately after the other, each might choose a different crane, so that neither would

be able to help the other. If there are more than two cranes, the release of the second falcon must be delayed longer than in the former case, for it is easier for a falcon to select and separate one of two cranes than one of several. A falcon prefers, if possible, to fly at a bird that is being pursued by another falcon rather than at one that is not being so followed. She makes this choice, not because of any enjoyment of the efforts exerted to capture the prey, but to be able to feed upon it.

When two such falcons have thus learned their lessons, other falcons may be trained by them—either a third by the two together or by one alone (as was noted in the case of the first novice)—but in this instance the falcon that is most to be relied upon should be chosen as teacher.

Gerfalcons and sakers are among those that are least willing to fly double. It is true that they sometimes work well in a cast while still in the air, but when they do they often crab each other after they have captured their quarry, especially if no assistant immediately intervenes; and then the quarry usually escapes. For this reason neither gerfalcons nor sakers should, as a rule, be flown in a cast. However, when that arrangement is necessary, two may be flown together, as in the case where one is taught by a second; but to fly a third with them would be dangerous.

Peregrines and noble falcons, who are not so strong or competent in taking their prey as gerfalcons and sakers, may be flown as many as three together with good results; and the cranes will be unable to escape.

When falcons have been taught to fly double and each does her best to capture the cranes, they may be expected to fly satisfactorily alone. This is true whether they flew naturally in a cast or only after instruction. It must be remembered that in order that they may fly successfully alone they must not be flown continuously together, for if they fly uninterruptedly in a cast they develop bad

¹ Book III, chapter xvi, p. 246.

² *et non sint gruerii.*

habits. When one falcon expects always to be assisted by the other she loses her desire to fly alone. Also those falcons that crab on the quarry cannot be flown long together, especially if they are gerfalcons or sakers.

CHAPTER XXV

ON THE VARIOUS MODES OF FLIGHT DISPLAYED BY FALCONS ENTERED TO STANDING CRANES

Since falcons of various kinds fly at standing¹ cranes in different fashions, it follows that they attack flying cranes also in various ways, although not all these methods of flight are equally commendable. We must therefore explain the typical modes of behavior of falcons when flying at both standing and flying cranes, so that we may know which method of flight is preferable; that is, which one gives the best promise of success.

When a falcon flies at a standing crane it may be in any one of a number of ways. Her flight may be high, low, or at a moderate height. Falcons that pursue a high, straight course may fly either swiftly or slowly, while the flight of others may be high and broken, fast or slow. Those falcons that keep close to the ground may pursue a swift or a slow flight and in either case follow a direct or an indirect line. Finally, the intermediate flight of a falcon (i.e., one that is neither high aloft nor close to earth but at about the level of her position on the hand of her mounted carrier) may exhibit any of the four characters we have described.

A falcon pursues a high, straight, and fast course in order to overtake quickly the crane she has selected after the latter has risen from the ground, and in order to strike hard. Those that take a swift but indirect course do so in

order to have the wind in the best direction, if they have not already been slipped into it. Those high flyers that proceed slowly and by a roundabout path do so both because of the wind and to give the cranes time to rise, for they are afraid to attack quarry on the ground.

When falcons fly near the ground they do so to take the cranes standing (and not flying), as when they flew at them in the train. If they fly slowly, it is because they are afraid of finding them actually on the ground. If they fly fast, it is to attack swiftly, not caring whether a crane is standing or has risen. Those that pursue an indirect course near the earth do so to gain the advantage of a favorable wind.

Those falcons that fly at either a great or a medium height and in a broken line do so because of the wind, and because they are afraid to attack a crane still on the ground and are waiting for the quarry to rise before they attack. Those that fly at a moderate height, and slowly, wish to allow time for the prey to take to the air. When they fly swiftly it is to reach the quarry before they have left the ground. When a falcon has been slipped directly into the wind and pursues an indirect path, it is because she is waiting for the cranes to rise, as she is afraid to attack near the ground.

The finest flights of all are those of falcons that fly high over the cranes, for then they descend with ease and grace in their stoop over the quarry. These lofty flyers must never be allowed to come down upon cranes standing on the ground, for in their earthward rush they may strike the ground and incur serious injuries. Cranes must be made to rise before the high-flying falcon stoops. She will quickly reach the cranes upon whom she descends, even though they rise and fly upward at a distance. The best results may be expected when the falcon flies high above her prey, stooping hard and throwing up well over her quarry when it is on the wing.

Falcons, when they are daring and eager,

¹ The word *volantes* has been here properly emended to *stantes*. This obvious error appears also in both the Mazarine and the Valencia text.

may fly at a moderate height in the attack on cranes; but although this makes a fine flight it is not as spectacular as that just described, especially if the cranes fly up at a distance, for these falcons are unable to overtake the quarry so quickly. The good points of such flights are that the crane, when pursued, is already on the wing and the falcons, though flying at a medium pitch, stoop and throw up, although not so frequently nor so well as when stooping from a lofty pitch.

Falcons that fly near the ground make less praiseworthy flights, for they are seldom successful in reaching the quarry, especially when it rises at a distance. The distinguishing features of such flights are that the crane is already on the wing as before and that few falcons that fly close to the ground are able to rise in sufficient time to stoop well over the prey. They seek rather to pursue and then to grab the crane.

CHAPTER XXVI.

ON THE VARIOUS MODES OF FLIGHT DISPLAYED BY FALCONS ENTERED TO CRANES ON PASSAGE¹

In flights at cranes on passage some falcons fly high over them and others below. Still others fly at a moderate height, on a level with the crane. As stated, lofty flights over flying cranes are the most laudable and promising, for the falcon whose pitch is high dominates the crane wherever it may be and does not permit it to fly far off. She can stoop harder and, after the stoop, rebound to greater heights, giving an exhibition of beautiful and elegant flying. She is less exposed to injury, since she can dominate the crane and not allow it to fly wherever it pleases or

¹ Quarry "on passage" may be defined as that discovered already on the wing (not found standing, nor flushed for the falcon) and attacked in full flight.

to travel far from the falconer's assistants, from whom she may receive help.

Falcons that fly neither high nor low but keep to a medium altitude make less remarkable flights (at flying cranes), because they merely pursue their quarry for a considerable distance until they are able to bind to it. This may occur at a point beyond the possibility of interference by the posted assistants.

Low flights at flying cranes are by far the least desirable, for at times the hunter fails to overtake her prey and when she attempts to throw up she barely succeeds in rising higher than the crane and the quarry makes its escape. Moreover, as the falcon rises to get above the crane, the latter may strike out and wound the pursuer by a blow with its feet.

Some falcons in overpowering the crane do not, after the stoop has hurled it to the ground, bind to it or settle near by but wait on overhead until a man or dog again raises it; then they stoop again. They repeat this maneuver until the crane can no longer rise and is captured by the assistant or his hound.

Other falcons, after striking or seizing a crane, force it to earth, but neither bind to nor hold it. They do not wait on above it but settle near the quarry on the ground and, when it rises for any reason, again force it down, and repeat this performance until it is captured by the falconer or his dog. Both these methods have the advantage of not harming the falcon.

There is a third method of capture wherein the falcon strikes and binds to the crane and carries it struggling to earth. This method is not commendable, for the falcon cannot battle with the crane without sooner or later receiving an injury from her quarry. Even though she escapes harm she is so tired out that she is seldom able to continue her pursuit of the quarry if it eludes her, much less to overtake it. Many falcons when thus defeated become so discouraged that for days they are unwilling or unable to fly at cranes; indeed,



Das scharfe Aug der schönen Jägerin Phyllis
 Sieht Phyllis Aug in: Sucht zugleich den Hirschen Hirsch.
 Wie Schatz wird es nicht fern, fürcht es sich unter Felsen.

*Venantis Phyllidis oculus acute cernens,
 Phyllidis ante oculos acrios dum praedat sagittas.
 Observat, quid non acrius illic videt.*

PLATE III.—“The Fair Huntress Phyllis,” engraving by August Vind, after J. E. Ridinger, from the collection of Dr. W. Schlüter, Dortmund



PLATE 112.—Persian falconer, from a drawing in the
Bibliothèque Nationale, Paris

some of them may never again be able to hunt unless they are given serious attention and diligent care.

The first of these methods of capture is better than the second, because while the falcon is flying about overhead she can quickly overtake a crane that has risen from the ground, while in the second instance she is not always able to do her duty. When the crane is forced down where there is long grass, bushes, or hollows, the falcon that waits on may be seen from a distance by the falconer's assistants, whereas a falcon cannot be seen when she sits on the ground. The first form of flight has the further advantage that the falcon cannot be harmed by other cranes coming (as is their custom) to the assistance of their companion prostrate on the ground. Nor has she to fear the wetting of her plumage from the moisture of rain or dew on the grass, and she does not suffer the disadvantage of attempting to rise through the stalks of long herbage or high grain.

The second method of attack, however, has some commendable features. To begin with, the falcon sitting on the ground keeps the crane under observation and with less exertion than in the first method, and she is more inclined to await the arrival of human or canine assistance before initiating her attack than is a falcon of the first type. In this position, also, it is easier for her to distinguish her selected quarry from other cranes that may come to its assistance. When they all rise together the falcon that waits on² has more difficulty in picking out its victim. The second method has the further advantage that the falcon standing on the ground is less inclined than one on the wing to check at another bird, for she does not so easily spy out a second (possible) quarry.

When the falcon flies slowly at standing cranes, no matter what her manner of ap-

proach, the falconer must release the dogs, but only after a short delay; for if he does it at once he may raise the birds too soon, also the slow-flying falcon may become alarmed at seeing a dog running beneath her and lose her keen desire to fly at the cranes, with the result that she either gives up entirely or makes a spiritless attack. However, if the falcon flies swiftly toward standing cranes, no matter what course she pursues, the dogs must be released with little delay after she has left the fist. The moment for loosing the hounds depends upon the kind of flight one may expect from a particular falcon and the distance to be covered. The greater the distance the sooner the dogs should be released.

CHAPTER XXVII

OF SHIRKERS AND THE TREATMENT OF THEIR INFIRMITIES

Since the size and strength of most cranes exceed those of many falcons, and as it is unnatural for falcons to capture such large birds of their own free will, they must learn this practice through the instruction and assistance of man. It often happens that in consequence of poor teaching and tardy help certain falcons become shirkers,¹ while, as a result of injuries inflicted upon them by the cranes, others become cowards.² We must now further discuss these terms and the reasons why falcons develop such unworthy traits, and how they can be cured of them.

Shirkers are those falcons that can perform better than they do but dissemble and give a poor account of themselves. Cowards are those that have been wounded by cranes and are therefore afraid, or unwilling, to attack or capture the quarry. Hence the difference be-

¹ *ficticii*.

² *repulsati*. Both shirkers and cowards may be classed under what E. B. Michell in *The Art and Practice of Hawking* calls "refusers."

² Cf. Book II, Author's Preface, footnote 9, p. 106.

tween them is that the one cloaks her true character and the other is really afraid. The shirker, if slipped at a weak or injured crane, will take it; but the coward will not touch any prey, injured or uninjured, weak or strong, so long as her fear lasts.

When a coward is exercised with the train that has been prepared with a strong crane, she will either not seize it or will attack timidly because she has (perchance) been injured by a crane. The shirker, on the other hand, has no fear of the crane, as she is well acquainted with and has never been hurt by one. The coward, however, is more quickly cured (of her fear), for she soon forgets her injuries; but the shirker is slower to break off her habit of malingering.

The falcon that has become a shirker through poor instruction may refuse to attack a crane for various reasons. For instance, her lessons with the train may not have followed the established order. For example, a weak crane may have been used for a time, followed by a stronger one, and later the order may have been reversed. Since she has learned in this manner to distinguish a weak crane from a strong one, she is unwilling to attack a wild crane, recognizing it as of greater strength.

Another reason why she has acquired this bad habit may be that she had not completed all the steps in the practice with the train when entered to a wild crane, with the result that she did not fly well and failed to take her quarry because it was much stronger than the crane used in the train. She was then flown again to the train and developed a liking for the captive crane. She has therefore no desire for flying to quarry. Or if she did capture the free crane, she may have been hurt by that bird or become so exhausted that the crane escaped. Such a falcon must resume her lessons with the train, since she has been insufficiently taught. This inferior instruction has two evil results: The falcon becomes both

a shirker and a coward—a coward because she has been injured and is consequently unable to hold her quarry; and a shirker because, having been returned to lessons with the train where the crane is weak, she has learned to recognize that fact. Excessive train practice also may result in the same defects.

A further cause of these evils is that sometimes, when a falcon is flown at a number of cranes and takes one, the others come to its assistance and between them they injure the hunting bird before human aid arrives. For this reason she is no longer willing to fly at more than one crane. A habit that may develop into the fault of shirking is that of selecting a young crane as her quarry whenever she is flown at a flock. She may also become accustomed to flying in a cast and acquire the habit of waiting for the assistance of her companion. Another cause of shirking (or refusing) may be that on some occasion when she failed to capture a crane at which she had flown, someone threw out a lure and fed her immediately, so that when she now flies at cranes she stoops once or twice but does not trouble to capture the prey because she hopes to be called to the lure and fed. Still another reason for refusing is that after she has been injured by them and has developed an aversion to cranes, she is put back to the train and in this way learns to distinguish between the wild crane (that harms her) and that in the train.

When, therefore, a falcon has become a shirker through improper train practice and is unwilling to take a crane, the falconer must determine at which step in the course of instruction she became a shirker and put her back to that point in her education. He must not, however, revert to those stages of her training that preceded the defective portion, for that would only increase her tendency to refuse. This experience demonstrates the necessity for adhering to an established order in the stages of train practice, using stronger

and stronger cranes until the falcon's skill is thoroughly developed. This is the method of cure (or treatment) adopted where sufficient cranes are available; but when they are few in number an experienced crane-falcon must be procured and flown in a cast with the shirker, provided, of course, that they consent to fly together.

Should a falcon be found unwilling to fly in a cast, or if there is no experienced crane-falcon to be had, the shirker should be treated in the following fashion: If she is fat, reduce her condition by several days of starvation. Now take a strong crane that flies well; attach this bird to a creance and permit the falcon to take it. Feed the falcon well on the crane, and then allow her to rest for several days; then, lowering her condition, but before she has become too weak from hunger, fly her at a free crane, taking good care that no harm befall her because of a poor environment or lack of prompt assistance. In this way, through hunger and the judicious use of the train, a shirker may be cured of her vice and made to capture a crane willingly and without delay.

If the falcon is not overfat, but rather on the lean side, so that she cannot be reduced without weakening her to the point where she is unable to take a crane, she should first be fattened for several days and then fed very little for a day or two, and finally entered to the train at the point where her instruction became deficient. After this, when flown to a wild crane she will take it because of her hunger. The period during which she is being fattened and then reduced in weight furnishes an interval of rest during which she may forget or abandon her habit of malinger.

If these methods of treatment are unavailing, then one should wait until the falcon completes her next moult. Then she should be reduced in condition, given train practice with cranes as strong as wild ones, and be well

fed upon the train. At this last stage of her re-education every effort should be made to conceal from the falcon the fact that the crane is a captive. She should now be flown at a few free cranes that may be relied upon to remain quiet and on a well-placed feeding ground surrounded by men who are ready and in positions to give immediate assistance.

Those falcons that have become shirkers through the second cause, i.e., that they were given insufficient practice with the train, should be allowed to rest for several days. If they have been injured they should be treated until the wounds inflicted by the cranes are healed, and if they are exhausted until they are rested and have forgotten their unhappy experiences. While they are at their ease they should be somewhat reduced in weight and then flown at a strong, captive crane. If the falcon thus treated does well and attacks her prey boldly, this treatment will suffice; if not, she should be flown again at an even stronger crane and a number of lessons of this sort (with the train) will do her no harm. However, this plan must not be chosen for shirkers who have been spoiled by too much train practice. Refusers of this last type should be treated like those in the first category, who have been made shirkers through an improper and irregular system of instruction with the train.

A falcon that is unwilling to fly at a group of cranes but will attack a single bird should be slipped with a second falcon at a flock (that is, if they are willing to fly in a cast). And this practice should be repeated until the reluctant one becomes used to taking one of a flock with the assistance of her companion. If such a falcon hesitates to fly readily in a cast, she must be re-trained by the methods already explained. Should no other falcon be available to make a desirable cast, take several cranes that have been somewhat weakened by hunger, put them each in a train, stir them up in such a fashion that they run about and flap

their wings, and allow the falcon to seize one of them. Repeat the performance a number of times.

A shirking falcon who invariably chooses a young crane from the flock should be starved a little for several successive days and flown at a flock of cranes among whom there are no young ones. This should be done toward evening when the shirker is in need of food. A small group of birds is preferable, and special care must be taken to have men posted to prevent the falcon from being hurt by the cranes. This procedure must be repeated many times until the shirker has taken a number of adult cranes. Then it will be safe to fly her under all conditions, even with young cranes in the flock.

Those falcons that shirk in the hope of receiving help from a companion and are unwilling to fly alone are quickly cured of this fault by separating the recalcitrant from her companion. The sooner this fault is noticed, taken in hand and the falcons separated, the sooner will she be cured. It will be noticed that when such a falcon is slipped ahead of her associate at cranes she will at once delay her flight until her companion has reached and passed her. Therefore it is bad practice always to fly the same falcon first (when they are flown in a cast); first one, then the other, should be made to take the lead.

When a falcon has been separated from her partner and is undergoing a course of re-education, she must be put on a reducing diet and then flown at cranes without an associate. If she takes even one crane, all is well; if not, she must again be flown in a cast, but far ahead of the second bird, so that one may observe whether she makes any attempt to take a crane alone. If she does, she must be flown even farther ahead of the second falcon, so that she receives less help from her. This experiment must be repeated a number of times until the falcon works entirely without her companion; or else she may be given an asso-

ciate who affords her little or no assistance, so that any crane that is captured in this cast is taken by her and not by her companion.

A falcon that becomes a shirker through being recalled to the lure and fed may be cured as soon as she develops this practice. The first few times she is flown to cranes it is necessary to feed her at once, but this treatment must not be continued long enough to make a habit of it. When it is seen that she is beginning to expect food, she must not be called to the lure or fed immediately. Moreover, when she has her meal, (after a little delay) give her a poor quality of washed meat. In this way she will not forsake the crane in the hope of returning to the lure and being there bountifully fed. If this scheme is not effective, fly her in a cast with another falcon—assuming that they are both ready and willing. Arrange the flight so that the companion precedes the recalcitrant by some distance; then the shirker, seeing her associate far ahead, will hasten to overtake her and will forget about the lure. Do this until (with an associate) she has taken several cranes. If no companion is available for such a cast, the poorer falcon must be flown at a train made with flying cranes.

CHAPTER XXVIII

OF COWARDS AND HOW TO DEAL WITH THEM

It may happen occasionally that a falcon (wounded by a crane and thereby made a coward) after being given a course of train exercises, loses her desire to take wild cranes because she has learned that they are stronger than those of the train. In this case the faint-hearted one must be first rested for several days to allow her wounds to heal and that she may forget her misfortunes. After a season of inactivity reduce her weight and let her be flown at cranes. If she still refuses to

seize this quarry, she should be flown in a cast, and if this latter method succeeds her companion may gradually be withdrawn. When no associate crane-falcon is available, make a train of the strongest possible crane and let her have it while it is on the wing. If all these plans fail, one must just wait until the stubborn falcon has completed her next moult, when she will probably prove more amenable to the usual processes of training.

As we have stated, there are many causes for falcons becoming cowards. The first is that when a falcon, newly entered to cranes and flown at a large flock, captures one of them, the other members of the family come to its rescue and, attacking, injure her. This defeat may cause her to lose all desire to take cranes, especially if the experience is repeated.

A second cause of cowardly refusing is flying a falcon in unsuitable territory where her rescue is difficult, e.g., where there are large bodies of water or other dangerous features. Under these circumstances she may capture a crane and in the ensuing struggle fall to the ground at a point where no help can reach her, with the result that she is seriously injured and completely exhausted. Or she may be so lacerated that she is forced to release the crane. If this is repeated she may easily become a coward.

A third reason for her cowardly behavior may be that when she was first flown she failed several times on the same day to take her quarry; and this unpleasant event, happening several days in succession, decided her to refuse thereafter to make any real effort.

A fourth set of circumstances may produce a coward, viz., the falcon, flown in a cast, may be crabbed by her partner while on the crane. She then believes the crane, especially if it escapes, to be the cause of her distress, and so becomes a refuser.

A fifth cause may be that the coward has checked at easier avian prey when flown at cranes, has made a capture and has taken a

good meal off the strange bird before she is interrupted. If this happens more than once, she may flunk her duty altogether and decline the battle against any cranes.

A sixth reason is that while she is on the crane the attendant dog, or horseman, in coming to her assistance accidentally does her an injury; or some inexperienced falconer may take the quarry from her in such a way that she is harmed. Any or all of these acts may cause her to refuse cranes.

Those falcons that become cowards for the first reason and have been injured, or wounded, should be given rest and be well fed. When they have recovered and have undergone a certain amount of starvation, they should be flown in a cast at cranes. Assistants should be carefully posted around the hunting area so that one or other of them will be able to help the falcon promptly. She must not always be flown double, as then she learns to expect help on every occasion and becomes a shirker. She must be exercised in a cast only until she has captured one or two cranes, then be fattened and again starved for a day or so, and in her keen state flown alone at cranes. If there is no available make-hawk, she should be flown at a strong crane, flying in a train, so arranged that she will not be subject to injury. For several days thereafter her diet should be reduced before she is once more flown at free cranes. When first flown at wild cranes, a make-hawk should if possible accompany her. If not, care must be taken not to fly her at large flocks.

When a falcon becomes a coward from the second cause, she must be allowed to rest until her wounds are healed. Since she will, in the meantime, grow fat, her condition must be lowered before she is flown at cranes. Care should also be taken against a repetition of the accident that befell her when she came down out of reach of aid. If she will now take a crane alone, all is well. If not, fly her in a cast as we have indicated or, when a make-

hawk cannot be procured, put her to the flying train.

If the third cause, just mentioned, is the reason for the falcon's refusal, let her rest a few days, fatten her, and then reduce her to her former lean state, or a little more, if she can stand it. Then give her as strong a crane as possible, flown in a train but in such a fashion that she will not perceive the bird to be a captive. Finally fly her alone to a wild crane or, if necessary, with a companion.

A falcon that has become a coward of the fourth category should be kept inactive, like the others, for a few days to permit her wounds to heal and until she forgets her unpleasant experiences. She must then be reduced a little (or more if she has already taken several cranes) and flown alone at her quarry. If she has not previously captured cranes, she should, after the aforesaid treatment, be flown at a flying crane attached to the train. Then fly her in a cast at the lure and, when it is seen that she works well with her partner, let them together attack free cranes. The timid falcon will then lose some of her fear, so that after she has taken several cranes with her companion she may be flown alone. If the cowardly falcon has previously captured cranes alone, she should have a rest for several days, be fattened, starved a little, and, finally, flown by herself.

Under the fifth set of circumstances the pusillanimous bird should be treated by rest and during this period fattened, then reduced in weight and given (last of all) the strongest possible crane flying in a train. This must be done in locality where there are none of the birds at which she checked when previously flown.

The falcon that has become a coward for the sixth reason should be rested until her injuries are healed, after which she should be held and fed in the presence of a dog so that she may lose her fear of that animal. She may then be flown at cranes. If she will not take a

crane alone, fly her with a make-hawk, if possible, until she has taken several cranes; then she may be flown alone at this quarry. If no make-hawk or other falcon (that can be flown in a cast) is available, pursue the alternative course described above. If she has been injured by a man, apply the same course of treatment.

To all cowardly falcons rest and mild starvation are of benefit, especially when they are overconditioned. But if they are thin when their bad habit of refusing was acquired, they must not be reduced further, for extreme hunger will weaken them. If they have been kept quiet and reduced in weight because they were too fat, and this regime does not effect a cure, slip them at a strong, flying crane attached to the train. This should cure them, for now no weakness of the crane reveals the fact that it is captive. This ruse should not be used too frequently.

We have now discussed the proper method of teaching gerfalcons in particular to fly at cranes. But this method may be applied also, if desired, to other kinds of falcons. All the foregoing instruction concerning gerfalcons should be carried out with even greater care and attention to details in the case of such hunters as are less courageous and weaker than this fine species. In fact, the less brave and powerful the species of falcon, the more heed must be given to their training. This rule, modified to suit each case, applies also to individuals of the same species. What they lack in prowess and strength is made up by careful exercise with the train—when a crane standing, walking, running, and flying is used with proper regard for the regularity of operations. It should not be forgotten, also, that the frequent satisfaction of the falcon by feeding her good meat, as she stands on the crane, is one of these requisites.

Before going further into these matters, it must be admitted that lanners cannot easily be taught to capture cranes, since they are not

strong, bold, or swift enough to fly at this quarry. The work of training them would be excessive and the rewards small or nil. It may also be added that, although we have singled out the gerfalcons as the crane-falcons par excellence, the fact must not be overlooked that she is very easily taught to hunt everything that any other falcon can chase and with greater facility and swiftness, since she excels in courage, power, and speed. By whatever method other falcons are taught to capture any bird the gerfalcons may be instructed even more expeditiously to do the same.

CHAPTER XXIX

HOW OTHER SPECIES OF FALCONS COMPARE WITH GERFALCONS AND WITH EACH OTHER AS HUNTERS OF CRANES

So far we have been discussing methods of teaching gerfalcons to hunt cranes and the proper method of capturing this quarry, and we maintain that gerfalcons are better crane-hunters than any other species of falcon. Nevertheless, the latter, when taught to fly at cranes, exhibit some great and others less success, depending upon the varying flying powers of the individual as well as of the species to which it belongs. Let us now consider in what respects different falcon species resemble or differ from gerfalcons, and from each other, as hunters of cranes.

Sakers resemble the gerfalcons in that they may be taught by using the train and by flying them in a cast. When they have been thoroughly exercised with captive cranes, they are not easily induced to check at other birds. Sakers, moreover, exhibit modes of flight similar to those of gerfalcons when attacking standing cranes. They also fly in exactly the same manner when they assault their prey on the wing, and they strike with identical speed. Moreover, their method of rushing their

quarry to earth is the same as that of the gerfalcons. The flight of sakers, however, displays some differences: They do not overtake the cranes as swiftly, nor stoop as often as gerfalcons, nor have they such complete control over their quarry, for they are neither so courageous nor so powerful as the nobler birds. They are also more embarrassed by bad weather and are not so invariably successful in hunting cranes. When slipped at a quarry on passage at a distance (an easy prey for the gerfalcons), the saker hardly ever captures it. Another peculiarity of the saker is that she may be swifter in flight before her first moult than after it. This is not true of the gerfalcons.

The peregrine falcon resembles the gerfalcons in that she can be taught to take cranes, and in her flight she approaches that of the larger falcon in swiftness more nearly than any other species. This is true also of her bold spirit. Bad weather affects her less than it does other species, and her energies do not deteriorate after the moult—characteristics that are shared with the gerfalcons. The latter, however, holds pride of place over even the peregrine in strength, speed, courage, and indifference to stormy weather. The peregrine is somewhat more inclined to check at other birds than the gerfalcons, and she does not stoop so frequently nor throw up with such facility after the stoop, nor does she keep the crane so completely under her control. Indeed, peregrines are not, as a species, so uniformly fine in their flights at cranes as the (larger) gerfalcons.

Among the true noble falcons, branchers show almost the same qualities, when compared with gerfalcons, as do peregrines in the hunting of cranes, since they belong to the same category. Further differences between noble falcons and gerfalcons will be spoken of later when we compare noble branchers and peregrines.

The nestling of the true noble falcon

resembles the gerfalcon in that she can be taught to fly at cranes and by the same methods. She may be slipped in the same manner, and she is not more prone to check at other birds than is her larger relative. The noble eyas, however, excels the gerfalcon in her agility and boldness of flight when entered to the train, and she completes the various grades of practice with that device more rapidly than the gerfalcon. She also takes more readily to and puts greater effort into her flights at standing cranes, when she flies nearer the ground than do gerfalcons. But when she is slipped at a crane flying at a distance she rarely overtakes it. In this feat gerfalcons are proficient. In fact, the eyas is less attracted than a gerfalcon by a flying crane. Again, she flies low at a crane on passage until she is beneath the quarry, when she rises to seize it. She is more inclined to seize her prey in this fashion than to stoop at it, and when she does stoop she does not turn upward again and get above it nor tire it out with long flights. The noble eyas is rather more likely to check at other birds than is the gerfalcon, though in neither of these birds of prey is this a frequent fault.

Having compared the gerfalcon's flights at cranes with those of other falcons, let us see how the latter resemble or differ from each other when flown at that quarry. These comparisons (including the four given above) number ten in all, i.e., four, three, two, and one.¹

The saker and the peregrine are alike in that they may both be entered to cranes by the same use of the train, and are slipped at cranes in similar fashion, although there are

¹ The gerfalcon is compared with the saker, the peregrine, the noble brancher, and the noble eyas (four comparisons); the saker is then compared with the peregrine, the noble brancher, and the noble eyas (three comparisons); the peregrine is compared with the noble brancher and the noble eyas (two comparisons); and, finally, the noble brancher and the noble eyas are compared. This makes in all ten comparisons.

some falconers who fly a saker down wind instead of into the breeze. We do not favor this last practice, for the various reasons given in our chapter on slipping the gerfalcon at cranes.² The peregrine is a swifter and more courageous bird than the saker, though smaller and not so powerful; she is, however, more likely to check at other quarry. The peregrine is less affected by strong wind and bad weather than the saker. Also, when flown at a distant crane on passage, the peregrine overtakes her prey more frequently than the saker, although she is less given to long flights than the slower saker. Nor does the peregrine share the saker's tendency to deteriorate in flying power after the first moult.

The noble brancher and the saker compare with one another in the same manner as do peregrines and sakers, but the brancher of the noble falcon is neither so strong nor so swift as the peregrine.

The noble eyas resembles the saker in that she may be educated to undertake flights at cranes and is flown at them in the same manner as the saker. In their flights they both are adversely affected by stormy weather. They have the common virtue of not checking easily at other birds when flown at cranes. The noble eyas seeks to grab her prey rather than to strike it in a stoop, in the manner of the saker. She prefers to seize her quarry from below, as is the habit of nearly all eyases of whatsoever species of falcon. This is not true of the saker. Eyases for the most part do not follow the quarry for long, but all their movements are quick. The saker, however, is slower and more persistent. A noble eyas is a little more inclined to check at another bird, but neither she nor the saker is a serious offender in this respect.

Since the peregrine falcon and the true noble brancher are of similar species, they may be taught to hunt cranes in the same manner. These varieties of raptors may be

² Book IV, chapter xiii, pp. 285-86.

given the same instruction with the train and other lessons in flying, and they are slipped at cranes in the same manner. The noble brancher and the peregrine will fly and perform their duties in almost identical fashion and are alike in their tendency to check at other quarry. The brancher, however, is not so strong nor so bold as the larger (peregrine), nor is she so swift and powerful in her maneuvers. She will often check at birds smaller than those that the swifter peregrines can follow, and will go after such small birds as starlings that are often found in the fields. Bad weather is a greater obstacle to noble branchers than to peregrines.

The noble eyas, who (in many ways) is closely related to the peregrine, may be taught in the same manner to capture cranes. She can be instructed by means of the train and slipped at cranes in identical fashion. The eyas is more easily entered to the train and completes her lessons more quickly than the peregrine. She is, however, not so strong nor so swift, and flies more readily at standing cranes, keeping closer to the ground. In flights at distant cranes on the wing she is rarely successful; in this latter respect the peregrine excels her. The noble eyas, in pursuit of her flying quarry, flies below and then rises to seize it. This is not a trick practiced by the peregrine. The noble eyas is more eager to capture than merely to strike her quarry; and when she has stooped she makes no effort to throw up for a second trial, but tries instead to seize the crane. This the peregrine will not attempt.

The eyas of the noble falcon compares with the noble brancher, in almost every respect, in the same manner as with the peregrine, since they are of the same species. They are taught to hunt cranes in the same fashion. But the eyas flies better at the train and finishes her instructions more quickly than the brancher. She also takes more pleasure and is more expert in flights at standing cranes, flying more swiftly and closer to the ground. However, the brancher is to be preferred to the eyas in flights at cranes on passage, for the former will capture a crane flying at some distance more frequently than the eyas, who approaches her quarry from below, and rises to grasp it. The brancher, unlike the eyas, will stoop and then throw up for a second attack, while the eyas is intent upon seizing her prey direct. She will not, however, persist in so long a flight as the brancher. The noble eyas will not check at other birds as often as the noble brancher.

The same differences and similarities displayed between noble branchers and noble eyases, in their flights at cranes, obtain as between eyases and branchers of other species.

Such, then, are the comparisons that can be made between gerfalcons and various other falcons, as well as the relations between various other species. Additional likenesses and differences are to be found, but what has been said should suffice to indicate the sundry modes of flight employed by diverse falcons when flown at cranes.



PLATE 113.—Saker, *Falco saker*. Adult female.



PLATE 114.—Barbary falcon (after Brodrick and Salvin)



PLATE 115.—Hobby. Adult male.



PLATE 116.—Female merlin, immature (after Brodrick)

BOOK V

HERON HAWKING WITH SAKERS AND OTHER FALCONS

CHAPTER I

ON THE EDUCATION OF SAKERS BY MEANS OF THE HERON-LURE AND THE HERON-TRAIN

ADEQUATE account has been given in the preceding books of the instruction of gerfalcons and other raptorial in hunting cranes. As the saker is larger than all other falcons, with the exception of the gerfalcon, we shall attempt in this present book to explain how sakers are trained to hunt. And since they are at their best and exhibit their most beautiful flights at herons, we shall give special attention to methods of teaching them to take this quarry.

When a saker has been completely manned, she should be called to the lure in the same manner as the gerfalcon. There is, however, this difference: the crane-lure for the gerfalcon is made of only two crane wings, since their weight is sufficient to prevent the gerfalcon from "carrying" it; but the lure for the saker must be made of heron's wings that are lighter than those of the crane and, therefore, two of the former have been found to be insufficient because the saker can raise and easily fly away with them. To prevent this, the heron-lure must be constructed of four wings bound together. This is particularly necessary in the case of the saker, since she, among all falcons and gerfalcons, is most given to the fault of bolting with her prey.

¹ Flying off with it.

The wings should be those of either white² or ash-colored³ herons, depending upon the color of the heron to be hunted.

Even after a saker has had ample training with the lure, it is unnatural for her to take herons unless she has first been educated for that purpose by a falconer. As the only means of giving proper instruction is with a heron-train, we must explain how this is done. Before she is flown to the train (that is, after her education with the lure is complete), she may be slipped at those birds that sakers habitually take when hunting for themselves. By following this rule she will grow accustomed to receiving human assistance when hunting before she is flown at the heron-train. This method has proved to be the best and most effective form of instruction. Falconers who wish, after her initial instruction (with the lure), to enter her gradually to the train may do so after she has become thoroughly educated in flying to the former decoy.

CHAPTER II

ON THE FEEDING OF HERONS KEPT FOR USE IN THE TRAIN

The falconer who proposes to employ a heron-train should have on hand a number of these live birds. He will be unable to keep them very long unless they are well fed, and

² This might be the great white egret, *Herodias alba*.

³ Probably the common European heron, *Ardea cinerea*.

as they are more difficult to feed than cranes or other birds, we shall now give the necessary directions for a suitable diet and its proper mode of administration. Herons that have been taken very young from the nest are not difficult to feed, since they open their capacious mouths, asking for food just as they did from their mothers. While their mouths are wide open it is easy to feed them the meat or fish they crave. A piscine dietary is best because it forms their usual fare; if fish is not to be had, meat may be given, but they should receive less of that viand than of fish. Let the meat be of chicken cut in small pieces and wet with fresh water. In fact, whatever food is given captive herons should be thus moistened. When they have been fed and it is evident that they are not eager for more, let that suffice.

Larger herons, that were not taken from the nest but have been acquired in some other manner, are more difficult to feed; for when taken wild they are unwilling to open their mouths because they see that they are among men (whom they normally shun) and, therefore, do not expect to be fed; indeed, if their mandibles are forcibly separated and food is inserted they will not retain it but will eject whatever is given them. Consequently they must be seeled and fed in the following manner: Their repast, whether of meat or fish, is first prepared in water, as directed, and forced on them in the same amounts as are given to herons taken from the nest. The falconer should have on hand a ring of cord, or other material, the size of the heron's beak. This he can slip over the bird's mandibles up to the nares to make it impossible for it to open its mouth. This is done because the heron, after it has been given several portions of meat, will regurgitate the ration into its mouth, intending to eject it. When the heron has tried this several times without success, it will swallow the food and retain it until digested. After a heron has been fed in this manner a number

of times it will become tame and used to taking food from the men that attend it. After a few days the heron may have its sight restored, and will grow more and more domesticated and accustomed to feeding in the presence of human beings. In addition to soaking a heron's meat or fish in water, one should also wet its feet and legs, because as a wader it is accustomed in its wild state to walk about in mud and water.

CHAPTER III

ON FLYING SAKERS AT THE HERON-TRAIN

As most sakers are less courageous than gerfalcons, they should be brought to a sharp-set condition before introducing them to the heron-train. When this has been done, take a heron¹ of the same color as those at which the falcon is to be flown, either white or ashen, and seel it. Bind its mandibles (as is done with cranes) and draw its legs together with jesses, so that by pulling an attached cord it can be made, when standing upright, to fall to the ground. Now tie some meat on its back between the wings, as was done with the crane. An assistant should be present to hold the end of the line. When all is ready, the falconer bearing the falcon should show her the heron, and if she gives any sign of wanting to fly at this quarry she should be released. If she fails to see the heron because it is motionless, let the man holding the line pull it gently so that the heron moves its wings, but does not fall to the ground. As soon as the falcon sees this movement she must be slipped. When she has taken either the heron, or the meat on its back, unless other herons are on hand

¹ Bologna MS., fol. 107^r, col. 1. *Ayro seu Herodius* (heron or egret?). Frederick uses most frequently the word *ayro*. Other forms are *heiro*, *heironus*, and *herona*.

for further trains and the falconer is willing that the falcon behead this one, the nearest attendant must interfere to protect the head and neck of the captive heron lest it be decapitated. If the meat on the heron is unsuitable as provender for the saker, give her a pigeon of the same color as the heron, to be offered in the following manner: Take the pigeon by the head and feet and thrust it under the heron's wing, keeping the hand concealed. Present the pigeon's exposed breast to the falcon and allow her to deplume it. Then incise the skin and feed her on the flesh of the pigeon's breast, as if it were that of the heron and not of another bird. If no pigeon is available, feed the saker on other good meat, held in the hand and concealed under the heron's wing (as in the case of the crane). The falcon should be flown at the train until she readily seizes the heron with the meat.

As these lessons continue, the amount of meat on the (decoy) heron should be reduced very gradually; and the man carrying the falcon must stand each day a little farther from the heron until the falcon is so far away that she cannot see the food on the quarry. When she takes the heron quickly (when thus flown from a distance) and does it without the incentive of meat—i.e., only for the sake of the heron—then remove the bait and cease its use entirely.

From the time the meat is removed and the train lessons are resumed without it, there is no further need (as in the case of the crane) for jesses to be tied on both feet of the heron to make it fall to the ground, for that bird is weak and not powerful, like the crane, and it tumbles easily when grasped by the falcon. After it topples over it is not able to wound the falcon with its claws, as does a crane. The heron should now be fastened to the train (above one knee) by a single jess and cord; this tether is enough to prevent its escape. The heron, blinded by ciliation, generally stands

still and does not move even its wings. But since it is more difficult for the saker to see a motionless heron than one that moves, the cord is pulled to make it flap its wings and so attract the falcon's attention. The line must, as stated, be attached above the knee, so that when it is drawn in, the heron will not fall over but will move its wings, as if starting to fly. This movement, which is already familiar to the falcon, will serve to identify the prey and enable her to recognize it when it stands still. It is the habit of herons¹ to remain almost motionless, making it difficult for a falcon to see such quarry; and this effect of imperfect vision is increased when there is no meat placed on the heron's back. Thus, movements of the heron's wings, when it is attached to the train, help the falcon to see the prey.

The falcon should not be flown to the train every day after the removal of the meat, but only every third day.² On the occasion of her flight to the train she must be well fed; on the following day her ration should be reduced. Full meals will preserve her strength; the smaller ration will make her more sharpset and eager for the train. Were she flown every day she would have to be fed in one of two ways, either a full ration each time, or a reduced portion. If the former method were chosen she would lose her keenness in flying at the train; if the latter, she might become too weak to fly and in this way also lose interest in the train. Hence it is best to let her go hungry one day and feed her well the next while standing on the train. This latter plan of feeding is the one usually adopted in all forms of practice with the train.

The falcon is now slipped at the heron train (without meat attached); if she seizes the heron boldly and without hesitation, the beak of the latter is thrust into the earth, and the falconer withdraws and permits the fal-

¹ Especially while fishing.

² That is, every other day.

con to decapitate her prey alone. There is little danger of the heron injuring the falcon, but if it is observed that the former has managed to inflict some injury on the falcon with its feet, the falconer on watch should go to the aid of his bird.

When the heron has been decapitated, if the victim is plump (a state easily recognized from the condition of the heart when removed), let the falcon also deplume it and feed on the flesh of the breast, as in the case of the hunted crane. If the heron is found to be thin and her flesh not nourishing, feed the falcon, instead, on good meat placed on the heron in the manner already described. Repeat this last step in training a number of days until it is clear that the falcon recognizes the heron easily and is eager to fly at it.

The ambulant train cannot be made use of in the case of herons, because they do not run along the ground. Nevertheless, a seeled heron may be forced to rise from its feet and fly so that the falcon will see it on the wing. When this is done the falconer holding the saker should release her to fly at the quarry. If she seizes it, she must be allowed to kill and eat it.

After the falcon has learned to capture a heron when rising and flying, she must be made sharp-set by starvation and flown the third day at a sighted heron that still has its mandibles bound. When she is expert in taking a flying and sighted heron (and there are other herons available), she must be permitted to kill and feed upon her quarry. But if herons are scarce, one should protect the captured heron as much as possible from the falcon, feeding the latter, in the usual way, with meat. Starve her the next day and fly her to the same heron, if it is not too weak and has not been injured by the falcon. In case it is feeble, use a stronger heron for the train; but when the latter has been actually seized by the falcon, substitute the weak one and allow the falcon to kill it at once and make her usual repast,

or feed her on (other) good meat. Practice with a flying heron in the train should be repeated until the falcon recognizes it immediately and seizes it boldly. The period of time devoted to each step of heron-train practice will depend upon the degree of courage possessed by each saker falcon.

This method of instruction with the heron-train is adequate for the teaching of gersakers, sakers, and noble falcons, including the peregrine. The lanner, who is neither so brave nor so strong as the others, requires much longer and more elaborate lessons in heron flying. That course of instruction will depend upon the possession or lack of boldness, strength, and speed. It will be found that falcons vary in their training requirements, not only from species to species but also from individual to individual, chiefly in the degree of their courage.

CHAPTER IV

ON THE SEASONS WHEN HERONS ARE FOUND IN VARIOUS REGIONS; AND ON THEIR NESTING AND FEEDING HABITS

We have now given a sufficiently complete explanation of the reasons why sakers should be trained and flown to the heron-train in certain ways. But before describing how they are flown at free herons, and how they hunt them, we must at this point give an account of where and when herons are to be found—in what regions and at what time of year they are most common, and of the particular localities they are most likely to frequent in those regions.

In spring and summer many more herons are found in cold latitudes than in warm ones, that is to say, in the fifth, sixth, and seventh climatic zones. To be more explicit, while

one will find many herons in the fifth zone, more will be encountered in the sixth and many more in the seventh zone. In these regions (from the beginning of the spring) they nest and bring up their young, who remain in the vicinity of the nests until the end of the summer. Here the young herons increase in strength and size, fed by their mothers and nourished also by food found by themselves. Here they remain from the time the sun enters the sign of the Ram¹ until it passes into the sign of the Virgin,² that is, from the middle of March until the middle of August. There are, moreover, other reasons for their spring and summer sojourn in these regions. Here at this time of year they find abundant water in which they can fish and catch their natural fare. Northern waters are full of all sorts of aquatic life in early spring; and this is very helpful, because herons are among those birds that nest and produce their young early. The latter are hatched while the sun is entering the sign of the Ram.

Hérons nest in swampy reed-beds and in trees close to the water, as we explained in Book I. They dwell and nest near rivers and small bodies of water, where they fish for themselves and their nestlings. They also frequent plowed ground (near water) and may feed upon lizards, small snakes, and other creeping creatures.

At the approach of autumn (or, more precisely, at the close of summer or beginning of autumn, while the sun is in the sign of the Virgin and proceeding toward that of the Balance),³ at the time when the young herons are grown and the coming of winter is evident, there is a double threat to their existence. In winter the waters freeze and they are unable to fish and cannot support the bitter cold that now threatens them; so they congregate and prepare to migrate to warm climates. They

must leave before winter comes and before the waters freeze and the rigors of the north descend upon them. At the beginning of autumn, therefore, flocks of herons may be seen gathered together, ready to migrate, and many others are already on their way. When the sun has entered the sign of the Balance (about the middle of September) many more are observed in full flight. At this period of the autumn large collections are seen more frequently in the neighborhood of rivers, large lakes, and big swamps, as well as on the seashore wherever fresh waters flow into the ocean.

Migration cannot take place before the autumn because the young herons are not yet strong enough for a long journey, nor later when the rigors of winter (that they cannot tolerate) threaten them. For this reason few herons are found in cold climates during the winter. Those that do remain choose districts where there are sources of rivers and swamps of spring water that do not freeze. There they can fish and the wintry cold is generally not so severe and harmful.

In warm climates, by the end of spring and throughout the summer, few herons are to be found, because the main flocks have long ago left for their northern nesting grounds. While a few may still be seen in the fourth climatic zone, even fewer will be found in the third; and they will be extremely rare in still warmer regions because they are certain to try to escape from the summer heat of these southern countries. If any remain in the hot zones they frequent those less torrid districts where there are springs and flowing water that do not dry up in summer, and also where the air is cooler.

By the end of autumn and in winter, however, a great many herons are found in warm climates, where they seek food and take refuge from the cold of northern regions, which they cannot endure. Herons are especially abundant in parts of Egypt. Here the Nile begins

¹ *Aries*, March 21 to April 20.

² *Virgo*, August 22 to September 22.

³ *Libra*, September 22 to October 23.

to rise as the sun enters the sign of the Crab⁴ and continues swollen until the appearance of the sign of the Balance, that is, from the middle of June until the middle of September. The Egyptian river is then at its height; in fact it is so full that it overflows the entire region. From the end of September the flood begins to ebb, leaving all the ditches and hollows of the districts full of water, in which are found during the winter many fish and other food for these waders. In consequence of these favorable conditions more herons are discovered in the Nile territory at that season than in that of any other warm country we know of. There are still other explanations of the presence in the Nile country of so many herons. In these parts are found numerous field mice (that live on corn), and these rodents form a favorite repast for herons. Hence it is that while the sun is passing from the sign of the Goat⁵ to that of the Fishes⁶ (i.e., from December to the beginning of March) many herons are to be seen in some warm climates, while very few are found in cold regions, and then only near water that does not freeze. The rare herons found in cold districts always prefer the neighborhood of warm springs,⁷ in which they can fish, just as those that migrate to warm climates seek rivers, marshes, fens, and small lakes, where they remain the whole winter feeding and resting. They do not move far from their chosen habitat, nor do they allow herons belonging to other flocks to join them and fish in their waters. Here they may be discovered until spring arrives, unless for some reason they are driven away.

When spring comes, both adult and young birds begin the return journey from the warm south to milder regions and, finally, to the cool north to escape the extreme heat and

the drying up of the waters, and also to find food. For two reasons the older herons make the return earlier than their young relatives. One is that they are stronger and can fly with greater ease against the cold blasts from the north, and the other is that their mating and nesting seasons are at hand.

At the time of the return many herons will be observed on the rivers and along the seashores (wherever they can fish) as well as in valleys where fish-bearing waters collect. They also gather in ponds, inhabited by a certain kind of black worm with a big head and body and a slender tail,⁸ which it is said becomes a frog when full grown, as well as by other aquatic animals which they fancy as food.

In winter and summer, herons are found continually near their habitats, chosen in winter for the purpose of fishing and in summer for fishing as well as for other beneficial features required for raising their young (whom they do not abandon). Winter and summer are not proper seasons for herons to move from district to district, but during migration and the return they are not always found in the same localities, since they are constantly on the move. Whenever the weather favors a change of location, they fly off for a new resting place.

When weather is propitious, during either the migration or the return, herons are on the wing at all hours of the day and night, in both spring and autumn. But in winter and summer they never leave their habitat for a whole day or night unless they are moving from one large body of water to another; and then they fly either at break of day or at sunset. In summer, when they have young to care for, they go out to feed twice a day, morning and evening. During the rest of the twenty-four hours they remain standing near their young or over the nest.

⁴ *Cancer*, June 21 to July 22.

⁵ *Capricorn*, December 21 to January 20.

⁶ *Pisces*, February 19 to March 20.

⁷ *fontaneta*.

⁸ Tadpoles.

CHAPTER V

ON THE BEST SEASON FOR EDUCATING
A SAKER TO HUNT HERONS

Having described the countries and characteristics of the localities in which the greater number of herons are most frequently discovered during various seasons of the year, we can now decide which seasons are best for commencing the training of falcons to hunt this quarry, because some seasons are not propitious for that undertaking.

In regions where herons nest it is wise to begin the education of falcons to hunt them during the nesting season, for then herons are available to make trains, as well as for use, later, as quarry. About the middle of June, when the sun is entering the Crab, the young birds are leaving their nests and are weak and without experience in defending themselves against falcons either by flying or by other means, and at the time, when bodies of water are low and afford little protection, falcons flown at herons have the best opportunities for capturing their prey. Then, also, herons are found on good hunting grounds, waters are usually low, excellent weather prevails, and there are no strong winds to impede the flight of falcons while offering protection to herons, who fly better in strong winds than in light breezes. This fine weather generally lasts from the time the young herons leave the nest until they migrate. All these remarks apply to herons hatched during the entire year. After this period and all through October many herons are found in the temperate and warm zones to which they have migrated.

While the herons are growing larger and proportionately stronger, the falcons also are increasing in strength, courage, and skill. Therefore, as early in the season as the falcons have developed their full bodily vigor, their instruction should be taken in hand. This rule applies especially to sakers, noble

falcons, and lanners, who are among the first falcons ready for active duty, especially in those regions where they nest—whether they are taken as eyases or (a little later) when they have left the nest. If captured by man and trained for hunting at this season they will be so tamed and skillful when winter comes that bad weather and rough ground will have less harmful influence on them. The period just previous to the setting in of autumn is even better than autumn itself for training and exercising young falcons. It affords an interval when they can become tame, capable of resisting the rigors of winter, and able to contend with herons, whose strength also increases as autumn advances. Hence the early autumn is better for starting their training than the middle or end of that season.

The next most favorable season after late summer and autumn for instructing falcons to fly at herons is the time of the return (migration), for then many herons gather on small lakes and ponds and those falcons that have been flown during the winter have meantime gained experience in hunting. Then, too, the weather is improving. After the falcons have been taught heron hunting and have been allowed to become a little fleshy, they can be placed for a while in the mews and when they come out they will easily remember the lessons they have received and are still competent to be flown at herons. For these reasons, we repeat, the autumn and the period of the spring return are best suited to training falcons to fly at herons.

The weather in winter prohibits any training, also the heron quarry are then strong and it would be difficult for falcons to capture them. Indeed, not only weather conditions but also the state of the ground would be in favor of the quarry; and it must be remembered that when falcons fail frequently in their efforts to capture their prey they may easily become "cowards," making it difficult, later, to teach them to take herons. This is

true, especially during the winter, in the fifth, sixth, and seventh climatic zones where herons are scarce and the weather is not favorable for training falcons, owing mainly to the heavy rains and frequent winds prevailing in those quarters, that hinder flights. The rivers then become swollen, and the streams, full of water from the heavy rains, overflow their banks. In these deep waters herons are captured with great difficulty. In winter, whenever the small lakes freeze over, herons leave the minor ones and seek larger bodies of water and such swamps as are not covered with ice where they can find food and protection. Falcons, however, cannot hunt over these large expanses of water. Moreover, the sharp, cold, wintry winds are discouraging to them. From the foregoing one can conclude which are the best times of the year to teach falcons to hunt herons.

CHAPTER VI

ON THE WEATHER AND THE HOURS OF THE DAY BEST SUITED TO HERON HAWKING

Now that we have pointed out the most desirable seasons for educating young saker falcons to hunt herons, we shall next discuss the sort of weather and hours of the day that are best suited for that undertaking.

Clear, quiet days furnish the best flying conditions for the falcons, for (among other advantages) their wing and tail feathers remain dry and hard—a prerequisite for good flying. Cloudy days, with no wind, are also good and provide conditions that are not adverse. Foggy¹ weather is not auspicious, because it is embarrassing to both man and bird. The falconer cannot then see whither the falcon has flown and is uncertain whether or not

¹ The translators have taken the liberty of translating the word *nubilosum* as "foggy" (*nebulosum*). Cloudy weather has already been dealt with and, furthermore, the context of the passage requires this change.

she has captured her prey; consequently he does not know whether he should recall her to the lure, nor from which direction; likewise the falcon is unable to see the lure. In misty weather, also, the falcon may easily be lost and her feathers may become wet. Rain, or anything that dampens the falcon's plumage, is undesirable, as it hinders her flight. To the heron such weather is less of an impediment, for its feathers, even when sprayed with water, do not absorb the moisture. The heron's defense is in lofty flight; and a falcon weighed down with rain-soaked plumage cannot mount above the hunted bird. The falcon's feathers, the effective use of which is essential to her movements, are rendered unserviceable by damp, with (as stated) the result that she cannot rise high in the air to overtake her quarry.

Strong winds are always a disadvantage to young sakers. On the other hand, the heron, with its plumes and long wings, is buoyant and the wind raises it to heights the young saker falcon rarely reaches. This unfortunate situation arises either because she lacks experience in catching herons and therefore has no desire to hunt, or because she is unable to take them, since she lacks boldness and speed in ringing up. Hence it is that the novice saker may fail in making a capture and this failure may lead to further trouble. For example, when a heron is on a small body of water and is driven off, perhaps by the wind, if the bird perceives that she cannot again take refuge on the water—one of her principal means of defense—she will, with the aid of her wing power, ring high up,² thus placing the falcon at a disadvantage. On no account, however, must a novice falcon be flown at herons over large bodies of water, or indeed under certain other adverse circumstances that will be discussed later.

The best hours of the day for heron hawking are from early morning until about the

² To ring up, to mount swiftly in a spiral.

third hour,³ or from vespers⁴ until sunset. The intermediate hours of the day are not suitable for flying saker falcons at herons, and are to be avoided for hunting since at that time vultures and eagles are aloft wheeling about. Moreover, the intense heat of midday in spring and summer is detrimental to the flight of falcons, who at that time are unable to exert themselves. In the winter, however, these hours may well be used for hunting.

CHAPTER VII

OF LOCALITIES SUITED TO HERON HAWKING

Now let us speak of the particular localities that are best suited to flying young falcons at herons. Natural or artificial basins that are free of trees are good. From these collections of rainwater herons wading or swimming in them can easily be raised when necessary.

Next in order of choice are small winding rivers from which herons are quickly flushed and easily driven off. Because of the bends in the stream a heron soon finds itself some distance from a water refuge. But if the course of the river lies between woods, or if trees grow thick along the shores of the stream, the locality is not an appropriate one. Here a falcon, stooping at a heron, especially when rising for a second attack, may strike a tree or become entangled in its branches. Falcons⁵ are not naturally skilled in twisting and turning while in flight among trees.

Large bodies of water and wide rivers do not offer good opportunities for flying young falcons at herons, because it is difficult in such places for men to put up the quarry. When a falcon is flown in surroundings where herons cannot readily be made to rise at the proper

time, she may, exhausted by overexertion, become a coward.

We have now discussed the sort of locality in which a novice falcon may be flown. Other places should not be chosen until a falcon's manner of flight has been studied. For this purpose we shall have to investigate the various ways in which a saker falcon flies at herons, so that each bird may hunt in the environment and weather best suited to her style and method of flight. This matter will be set forth in the chapters on methods of flying young sakers at herons.¹

CHAPTER VIII

ON DRIVING AWAY BIRDS AT WHICH A FALCON MAY CHECK

As it is natural for birds of prey to abandon the pursuit of large birds for smaller ones, or for quarry that is easily taken, the falconer should be careful that there are no other birds near the herons at which he thinks the falcon may check when flown. He should proceed as follows: He must send a horseman to ride between the heron and any other birds that are present and, no matter whether the heron rises and flies away from the latter or they move far enough off to make a flight at the heron possible, then the falcon may be slipped. If the interlopers have not withdrawn far enough the horseman should ride at them again, either to drive up the heron or to scatter the smaller prey, whichever is easier. The choice will be influenced largely by the conformation of the land and the direction of the wind. It is better to drive the small birds up wind a short distance from the heron than a longer distance down wind, because it is natural for a heron to fly with the wind, and if the other birds are also dispatched down wind it will be easy for the heron to re-join them; and so the danger of the falcon's checking is renewed.

¹ Book V, chapters *xxi-xxiv*, pp. 342-46.

³ Nine o'clock.

⁴ *a vespere diei*, "mid-afternoon."

⁵ Unlike short-winged hawks.

CHAPTER IX

ON THE NUMBER OF HERONS AT WHICH A FALCON MAY PROPERLY BE FLOWN; AND ON POSTING ASSISTANTS AT THE RIVER

A large gathering of herons does not present the same (serious) problem that must be solved when a large flock of cranes is encountered, that of the flock helping one of its number attacked by a falcon; indeed, this is relief herons never offer. Flocks of herons, however, present other disadvantages. When a falcon is flown at a number of herons, she stoops first at one, then at another. She may start to fly at one and check at a second, so that this constant changing of quarry not only offers a degree of relief to the harassed herons but also fatigues the falcon and causes her physical distress, and in the end she may lose one heron by attacking a second.

However, when the herons are standing, somewhat separated one from the other, and the falconer has a number of falcons on hand, he may slip all of them at once at the herons or he may fly a single falcon as many times as there are herons standing isolated one from another. If a falcon is flown at herons in a flock, one of them may see the approaching falcon, when they will all fly off together; but if they are well divided, a falcon may be flown at one at a time and each flight be completed without driving the others from their watery habitat, since they have not been frightened by the flight of the falcon. Let me repeat: it is better to scatter the herons and fly the falcon at each one singly than to let her attack them gathered in a flock.

When a heron holds its neck and head drawn in close to its breast and shoulders, and stands quietly without turning its head toward the wind, (it is a sign that) it has no intention of flying off. But when it extends its neck straight out and stands on both feet, with body erect and wings and plumage flat

against its sides, and starts to walk away, meantime turning toward the wind, (these are signs that) it is about to fly off.

Although herons are not strong and can do little harm to falcons attacking them, and there is therefore little need to post men where they can readily help the falcon, yet certain features of the hawking ground or the weather conditions may make it advisable to have assistants placed at selected points. For example, if a river is unfordable and otherwise impassable, if the banks are high, or the river bed and shores are slimy, men should be stationed along the stream, not so much to protect the falcon from any harm the heron may do her but to put up the quarry when necessary. One assistant should be posted across the river, opposite the man flying the falcon, and two others posted down wind, one on either side of the stream. If the wind is blowing along a river that is unfordable and impassable by other means, one man may be sufficient to place down wind; but whether there are one or two, their distance down wind should depend upon the strength of the breeze. If the stream is fordable, so that neither its depth nor the height of its banks makes it impassable for a dog, one trained hound will be sufficient in hunting quarry; but if the river is unfordable, then two hunting dogs are necessary, one on either side of the stream. These hounds should be trained according to the instructions we have already laid down.¹

CHAPTER X

ON GENERAL PRECAUTIONS TO BE OBSERVED IN SLIPPING A FALCON AND IN PUTTING UP HERONS

We have already given directions governing the exercises and education of young saker falcons with a heron train, and have discussed other precautions that must be taken before

¹ See Book III, chapter xxviii, p. 267.

the falcon can be trusted to fly at herons. It is, in addition, very important to note and prevent the failure of a novice when she is first entered to herons, because such a failure to capture her prey the first time she is flown may have serious consequences. The only reasons why she should fail are the prevalence of adverse weather and unfavorable topographical conditions. Consequently we must consider how the obstacles presented by weather and terrain may be overcome.

When novices are flown, the best terrain and most favorable air conditions (as we have defined them) should be chosen. When a heron is discovered in a suitable locality and the wind is not blowing, the falconer may ride either up or down stream, whichever suits him, to slip his bird at the quarry. But if there is even a little wind he must be careful to head the falcon into it.

Although herons are birds that are not easily disturbed, nevertheless the falconer should not ride too close to them before releasing his falcon. He should take his stand away from them at about the equivalent of the longest distance used in practice with the heron-train. Such a position is better than a closer approach, because it permits the falcon to develop greater momentum in her flight, and if the heron rises to any height the former can more quickly overtake, strike, and seize the quarry. If she is unable to take the heron in the first attempt, because of its gyrations, she can easily throw up and stoop again, for the heron remains beneath her. Therefore, in flying a novice for the first time, it is well to slip the falcon from some hill or high spot so that she may fly downward.

Before reaching the point whence the falcon is to be flown, a horseman should be sent to put up the heron. This assistant should have with him a trained hound, and must place himself between the heron and the man carrying the falcon. He must not make the heron rise until he is sure that the falconer

sees that he is about to do so and has the falcon ready to fly. If the falcon is one not used to wearing a hood, her carrier should keep his body between her and the heron, lest she bate in her desire to fly at the quarry.

When the falconer has reached the place whence the falcon is to be flown he should stop and give her time to mute and rouse, if she wishes. If the bird is wearing a hood, the falconer must halt, remove her head gear, and, as before, wait for her to mute, rouse, and, in general, prepare herself for flight. When she has completed these preparatory acts, and the falconer has given the signal, the assistant must put up the heron, but not with too much force or too suddenly. The dog accompanying him must not be unleashed. At this point the falconer should turn toward the heron, and allow the falcon to see the quarry rising. He must keep an eye on his own bird and if he notices that she bates toward the quarry should throw her off. Even when she does not bate, if the falconer sees her flatten her feathers and stare at the heron, he must slip her, giving her a gentle toss with his hand, at the same instant loosing his hold on her jesses.

The falconer must now wait until his bird reaches the heron and stoops, and look at her closely to mark whether she is a slow flier and if she has any fear of water. If she is not afraid she will strike as boldly over water as on land; but if she is slow she will not rise high after the first stoop. If, on the other hand, she is swift but fears the water, she will not stoop at a heron that has taken refuge in an aquatic environment but will wait on until the quarry has flown off; and her speed may be measured by the impetus of her throw up¹ after stooping, when she leaves the heron well below her. The possession of these two good qualities—speed and courage—will be chiefly disclosed by the manner of a falcon's first performance.

¹ Cf. Book III, chapter xx, footnote 2, p. 255.

When flying falcons that are slow but do not fear water, allow a dog to put up the heron; and if no dog is at hand, send a man to perform this function; but he must take care lest any sudden action of his cause the heron to ring up. If the quarry tries to return to the water, the assistant should advance to the edge of the stream and by his presence prevent the heron from coming down. He must not cry out or wave his arms, or the falcon may think she is being called to the lure, and so permit the heron to escape.

In the case of a falcon who fears the water, but is swift in flight, the heron should be driven up forcefully, so that it will fly well away from the protecting water. For this purpose a dog should be employed if the heron can thus be driven off; but if not, or if no dog is available, then an attendant must flush the quarry and frighten it entirely away from stream or pond.

When a falcon has the two desirable qualities of speed and courage, the heron may be forced up suddenly; for even though the falcon does not fear bodies of water she can capture her quarry more easily away from them.

As soon as the assistant (who has flushed the heron) sees the falcon on the wing, he should stand still and not leave his post. In going in to send up the heron he should keep between the falconer and the heron, so that the quarry on rising will fly away from the falconer who is about to slip his bird. The assistant must not cry out or run toward the heron, lest the falcon (that has just been slipped), seeing him run and hearing the call, may desert the heron, expecting to have the lure thrown to her. Moreover, if he calls out and speeds after the heron he may prevent it from taking refuge in the water. The heron, lacking this refuge and putting its trust in its powers of flight and ability to maneuver

on the wing, may attempt to escape by ringing up. As a result the young falcon who is skilled in capturing only weak herons in the train will probably give up the chase, since she has had no experience of mounting above and seizing herons aloft.

CHAPTER XI

ON THE UTILITY OF DOGS IN HERON HAWKING

One purpose of canine co-operation is to prevent a heron, on seeing itself pursued by a falcon, from settling in the water or near it in search of security. The heron will be afraid to land near the dog; but if it does, the hound will force it again into the air. Every time it settles, it must be made to rise, for if the quarry remains in the water or near it the falcon, who fears all aqueous areas, will not dare attack; or, if she has learned to take a heron in a train on dry land and descends boldly upon a heron standing near water, it may use its long beak to strike her; and if she seizes her prey, the heron may again strike at her. Unless the quarry is made to rise quickly, the falcon will be unable long to wait on overhead. She will soon become fatigued and abandon her attack; and if she sees another bird she may check at it. It is important, therefore, that either a dog or a man be on hand to drive the heron into the air each time it tries to settle down. A dog is preferable for this task, since the fear of a running man may cause the heron to ring high up. This she will not do because of a hound, for she has no great fear of the canine interloper, at least not enough to cause her to seek security high in the air. Moreover, when a heron has been struck by a falcon a number of times, and is tired out, the attendant dog will be able to seize the quarry as it comes to earth.

CHAPTER XII

ON HERON HAWKING AT THE RIVER

If a falcon, stooping repeatedly, pursues a heron and the breeze carries it down wind until in its flight it passes beyond both the assistant who first put it up and the man who originally slipped the falcon, and if it then takes refuge in water at a point beyond the assistants stationed down wind, these men must leave the water's edge, lest their presence force the heron to fly still farther away. The falconer's aids should then run quickly with the breeze, so as to keep the heron up wind from them. Now, when once more they drive it into the air the heron will be forced against the breeze. This maneuver must be repeated as often as the heron tries to escape. Its fear of the men sent down wind will finally drive the prey into fields, away from the stream, on one side or the other, where the falcon can attack it with impunity. Also, the heron being forced against the wind becomes tired out and falls an easy prey to the falcon.

When there is no wind blowing and a heron is found in a small pool of rainwater, it makes no difference from which direction the horseman rides to slip his falcon; but, if there is a breeze, he should maneuver so as to fly his bird directly against it, while the man and dog that are sent to drive the heron into the air should follow their usual procedure.

If, on setting out for heron hawking, no trained dog is available, the man sent to flush the heron should do so in the regular manner, but when the heron has risen and the falcon has been slipped this assistant should stand perfectly still until after the falcon has reached or flown past him; then he should follow the falcon, for were she to see him running ahead of her she might check, in the hope of receiving something on the lure. His

fast pace might also shield the heron, and the falcon, not seeing it, might turn in another direction. Therefore the assistant must run behind the falcon toward the heron and drive the quarry up every time it takes refuge in a pond. This must be done without calling out and without the use of arm movements, lest the falcon's attention be shifted from the heron to the assistant in the expectation of being called to the lure. To repeat: When the wind blows along a river bed and the heron, flying in the wind, is driven to the ground by the attacking falcon at a point down wind and beyond the assistant, the latter must not force the quarry into the air from where he stands but must run down wind and drive it back, against the breeze.

When the wind blows from across the river, the assistant who has roused the heron should take up such a position that when the falcon forces the heron to the shore it will wing its way between the falconer and the assistant. Whichever is nearest the heron should now drive the bird into the air toward the other man, thus helping to force it from the river into the fields, where it is more easily attacked. This action also makes it difficult for the quarry to take refuge in the water, since to do so it must fly back, against the wind.

If after the heron has been driven ashore by one or both falconers it settles up or down stream beyond one or the other of them, the nearer man should circle around the heron, going away from the water but returning to it on the far side of the quarry. The other assistant should close in and again force the heron into the air.

If it is clear that the falcon is making a bold attack and the heron cannot escape, the latter should be made to take flight suddenly and leave the vicinity of the river. But when the falcon's attack is weak, the heron must not be driven up quickly and abruptly, lest the latter ring up too high. But if the heron

takes refuge in a lofty flight, everyone must withdraw from the river, so that the quarry will again settle down, to seek asylum there. When it does, it must be made to rise again, and as soon as it has left the water the assistants must once more withdraw, so that their presence will not make the quarry lose hope of being able to take refuge in the water and so spiral upward out of range. When this plan is pursued the quarry will fail to take advantage of either means of escape and easily be captured. The falcon will either seize the prey or so injure it with repeated blows that the falconer can take it. Even if it is not actually struck to earth, it will be rendered so weak by fatigue that it can be seized by either a man or a dog.

CHAPTER XIII

ON THE TREATMENT TO BE ACCORDED A FALCON THAT HAS CAPTURED HER PREY

When a heron is taken by a falcon, the falconer must drive its beak into the earth and leave it to the mercy of the falcon. He should stand close by, so that in case the heron frees its beak he can at once push that member once more into the earth. If the heron attempts to harm the falcon with its claws (although it can do little or no damage), he can hold its legs while the falcon decapitates it. The falcon should then be allowed to stand on the quarry until she has deplumed and begun to feed upon it. If, however, she begins her repast at some other part than the breast, the falconer should present her with the breast (depluming it and breaking the skin at some convenient point) and allow her to feed on it. If the falcon of her own accord deplumes the breast and breaks the skin, the falconer should enlarge the opening thus made and allow the falcon to begin her meal. She must not, however, be permitted, at this stage of the pro-

ceeding, to consume what would be a full day's ration. The falconer should take from the heron's breast enough meat to complete the repast (with what the falcon has already consumed) and, using it as an inducement, take the falcon from the heron and feed her on the fist.

There are those who, to please the falcon, after she has been fed on the heron and they wish to take her up, remove the larger of the forearm bones of each wing,¹ crack open their ends, insert the feathery part of a quill into the narrower end and push out the marrow, which is then given to the falcon. We do not attach much importance to this procedure.

If the falconer captures a heron wounded by the blows of a falcon, he must keep an eye on the latter, and if she circles about over the spot where the heron has been caught he must not recall her by means of the lure; but, taking the heron by the mandibles with one hand and by a wing with the other, he should display the quarry to the falcon, without calling out. While the falcon responds to this signal and is making her descent, he should insert the heron's beak in the earth. If he sees that the falcon is timid about approaching the prey because of his presence, he should withdraw a short distance until the falcon has settled on the heron, when he should carry on in the manner already described. The method is the same when the falcon does not approach a wounded heron, nor wait on, but settles on the ground near by. An exhausted heron may be treated in the same manner when captured.

CHAPTER XIV

ON CERTAIN RISKS IN THE USE OF TRAINED HOUNDS

The use of a trained dog in the capture of a heron may have any of the following consequences: When a falcon captures a heron

¹ That is, the ulna.



PLATE 117.—Episcopal throne in the Cathedral at Canosa, built in part by Bohemond, Prince of Antioch, son of Robert Guiscard. The whole building is remarkable for the animal motifs in its decoration, reminiscent of the "Bestiaries" of the Middle Ages.



PLATE 118.—Cathedral of Bitonto (1200). Matteo Spinnello da Giovenazzo describes standing before the doorway and seeing the body of Frederick II carried in procession on its way to Taranto—high on its crimson-covered litter, six companies of armed Saracen guards loudly weeping for their master as they went, and the long train of barons in black following the bier.

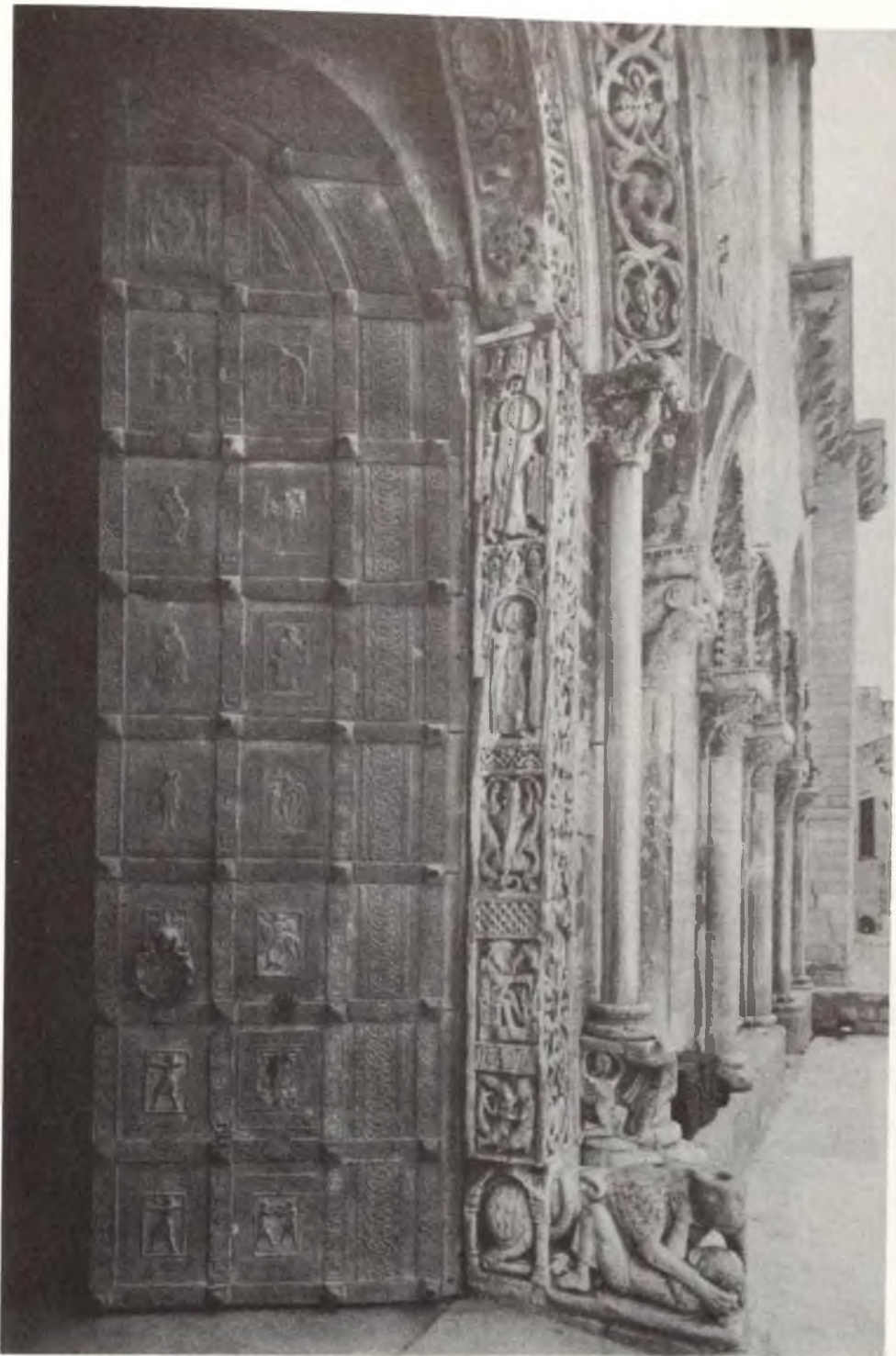

PLATE 119.—Façade of the Cathedral of Trani (twelfth century), showing details of the bronze doors and pilaster of the main portal. It was near Trani that Frederick built his great Castel del Monte.



PLATE 120.—Norman apse of Palermo Cathedral, where Frederick II of Hohenstaufen is buried (1250)

the dog that comes to her help may grasp the heron she now holds in her talons. When this happens there are two possible results: the falcon will either retain her grasp or else she will fly off. On the other hand, when the hound captures the heron first there are also two alternatives: the falcon may alight upon the prey even while the dog is holding it, or she may come close to but (since she is afraid of the dog) not actually settle on the quarry.

Of these four contingencies, the first is dangerous for the falcon, for the momentum of the dog's approach may prevent him from recognizing the falcon, who may be injured by this collision or by being trampled upon; or else the precarious position of the falcon may be greatly increased by the arrival of some other (untrained) dog.

The third method of capture is also dangerous, but less to be feared than the first, because the dog that has already captured and is holding the heron does not snap at the falcon, since to do so he would be obliged to release the heron. Nor is there any danger of the dog colliding with the falcon on his approach, since he arrives first. There is no other manner in which he can harm the falcon unless he belongs to the class of hounds that shake and worry their quarry.

The second and fourth styles in which a dog can seize a heron are the best; for if a falcon captures a heron but flies off on the approach of the dog, or if the dog makes the capture and the falcon remains aloof, not settling on the heron, there is little possibility of the dog harming the falcon.

When a falcon captures a heron and does not release it on the arrival of the dog, the man nearest the contestants must approach and remove the hound, without rebuke or threats if he has done no harm; but if he has worried the heron, or injured the falcon, or done other damage, he must be threatened with punishment, to prevent a repetition of the fault. If a dog is scolded when no harm

has been done, he may refuse on another occasion to seize a heron and so permit it to escape; or he may carry off the quarry and, in doing so, trample on, or drag along, the falcon clinging to it.

After the dog is removed, the falcon is left on the heron, whose mandibles must now be inserted in the earth. The heron's feet also should be held, although there is little chance of the quarry using them to inflict serious wounds on the falcon.

In all cases the dog is to be taken away (from the heron) whether or not the falcon has settled upon it.

The quarry must now receive special attention. When her mandibles and, if necessary, her feet have been secured, she may be left to the falcon. The dog must be given to someone to hold, so that when the heron is turned over to the falcon he may not interfere and cause the latter combatant to assist the heron.¹

If the falconer is alone, when he removes the dog he must hold him back, then press the heron's beak into the ground and withdraw, leaving the heron to the falcon. He can return later without the dog, driving him off if he attempts to approach the birds. The falcon must now be allowed to decapitate the quarry and, if this is her first capture of a heron, feed upon it, according to previous instructions and following the various steps therein specified. This plan should be carried out until at least three herons have been captured. When this part of the training is faithfully continued for some time, it will be found that the falcon will fly better and seize other herons more boldly.

Should the falconer wish to fly a falcon at a second heron, she should not be allowed to take a full meal from the first captive but may be given the heart only, after which she must be lifted from the quarry.

¹ In other words, by causing the falcon to attack the dog, permit the heron to escape.

These are the measures to be taken after a falcon has taken her quarry. The plan to be adopted when she fails to make a capture will now be considered.

CHAPTER XV

ON THE REASONS WHY A FALCON MAY FAIL TO CAPTURE A HERON

It often happens that a saker flown at a heron fails to seize it. There are many reasons for this failure, some of them connected with the falcon herself, others of extraneous origin. If the default is due to the falcon it is usually because she is either unable or unwilling to make a capture. Infirmity and emaciation, or some damage to her feathers, are the common causes of her disability. Her unwillingness is probably because of overfeeding,¹ or because of irregular and insufficient practice with the heron-train, or because she prefers to return to the falconer in the hope of being fed on the lure or wishes to go in pursuit of some other bird for which she deserts the heron.

The outside causes of the failure of a falcon to seize her prey have their origin mainly in the locality of the hunt, the weather, or the arrival of other birds that have injured or frightened her. All these incidents are impediments to good flight. Districts that are characterized by expanses of water, groves, or similar obstructions; windy, or otherwise unfavorable, weather; birds that interfere with the falcon's capture of the heron, i.e., wild falcons, ravens, crows, and such other species as obstruct her flight; eagles and vultures that she fears—all these are causes of a falcon failing in a flight at herons.

¹ The Bologna Codex (fol. 114, col. 2) reads *transiciem*; the Mazarine text (p. 465) says *grasitiem*; and the Valencia MS. (fol. 187) has *grasitiem*.

CHAPTER XVI

ON THE BEHAVIOR OF A SAKER THAT FAILS TO CAPTURE HER PREY; AND WHAT THE FALCONER SHOULD DO UNDER VARIOUS CIRCUMSTANCES

We must now consider how the falcon behaves when she has not made a capture, and how she may be recalled and cured of any bad behavior or protected against its effects. A falcon that has failed to capture her heron because of weakness, emaciation, the inadequacy of her plumage, or unsuitable environment or weather, because of birds that mob her,¹ or because of the advent of eagles, vultures, and other large birds that she fears, will do one of two things. She will either wait on² over the falconer, or fly off. In the latter instance she may settle down, either close at hand or some distance away.

If she waits on, the falconer must dismount, take the lure in his hand (holding it with the back upward), and move it about near the ground. As he shows it to the falcon he must not call out, lest she receive the impression of being lured. He must let her think that the lure itself is the heron. When she arrives she will expect to find meat; therefore the flesh upon which she is to be fed must be hidden under a wing of the lure, and drawn out from above, so that when she sees it, she will think it is the heron's flesh. When the falcon has been recovered in this manner, she must be fed at once.

When a falcon that has been unable to capture the hunted heron does not wait on, but flies off, a mounted falconer must ride after her. If he can travel fast enough to get beneath her, let him act as when she circled overhead. But if, owing to the swiftness of her flight, the falconer is unable to overtake

¹ *male tractant*.

² *circumgirare*.

the falcon, he must whirl his lure in the air—without calling out, for it is better for the falcon to come down without vocal encouragement. As soon as the falconer observes that she sees the lure and is beginning to descend, he must dismount and plainly show the decoy. Finally, he must take up the falcon and feed her immediately. However, if he finds that the fleeing falcon ignores both the lure and himself, he must call out, as he whirls the former, and so attract her attention. As soon as he perceives that the sound of his voice has made her turn toward him, he must cease calling, dismount, recover the falcon, and reward her with food.

When a falcon neither waits on nor flies off but comes down and settles near by, the falconer should make in,³ dismount, and, holding the lure near the ground with its back uppermost, show it (with the meat attached) to the falcon. He should then take her up and feed her at once. If for any reason the falconer cannot immediately approach the falcon,⁴ let him dismount at the point where she checked in her pursuit of the heron and, by making use of the lure, induce her to come to him.

When a falcon, because she is mobbed by other birds, or because of her fear of eagles or vultures, has failed in her flight at a heron, whether she waits on, flies away, settles down, or soars high in the air, she must (especially in this last case) be recalled to the lure as quickly as possible, and in any manner possible, by holding out the lure, by throwing it (with or without meat attached), or by calling out. When she has been recovered, she must be fed at once. When she is not recalled

at once in these cases, she may, either because of the injuries she receives from mobbing birds or because of her fear of large avian enemies, fly far off and be irretrievably lost. Sometimes it happens that, while she is on the lure, eagles and other birds she fears fly close to her and she will then fly off. At such times the falconer must not attempt to retain her merely by her love of the lure and its meat but must also take a firm hold on her jesses, for unless this is done the falcon may escape him.

When a falcon is unwilling to capture a heron because she is too fat or likes to be fed, or has had too little practice with the lure, whether she waits on or settles somewhere, she must not be recalled at once to the lure. If possible she should be recovered without the use of any tiring, especially if she has gone to roost for any of the reasons mentioned. If necessary, a tiring may be used; or, should this fail, the falconer should try the lure without meat and without vocal or other encouragement. When the falcon has been recovered and taken up, she must not be fed at once; for were her hunger satisfied immediately she would have even less desire on another occasion to fly at the heron, hoping always to be recalled and fed.

When a falcon has deserted a heron to check at another bird, she must be lured, in any manner possible, at the very spot where she checked, and when she has been recovered she must not be given a meal immediately.

Thus, all falcons who fail to take a heron, either because they are physically incapable of doing so or because of some extraneous obstacle that they cannot overcome even though they exert their best efforts, must be fed as soon as they are recovered. Falcons, however, who are unsuccessful because they are merely unwilling must not be given food when taken up, for they would then become more fixed in their bad habits and would act worse the next time they were loosed to quarry.

³ The method of circular approach used by a falconer when he wishes to take up his falcon.

⁴ The text at this point—*et carnibus appositis ut dictum est recipiat falconem et statim pascat si statim falconarius non statim non vadat at ipsum sed illuc ubi dimisit ayronem descendat movendo loyrum faciat ipsum venire ad se*—is not entirely clear.

CHAPTER XVII

ON SPECIAL CORRECTIVES FOR A
FALCON'S IMPROPER BEHAVIOR

The following are special correctives for certain undesirable conditions: If the falcon's improper behavior is caused by some infirmity, the disease must be determined by its symptoms and the falcon allowed to rest while she is being treated and until she is cured. If the falcon is emaciated, she must be fattened as much as is proper, then made as hungry as possible without becoming weak, and flown at once at herons.

Another cause of failure of the falcon to grow into a useful bird is a lack of symmetry in her plumage, which may be caused by the breaking of a feather or the incomplete development, after moulting, of a few or even all the flight feathers. If all (or many) of the feathers are affected, one should fly the falcon at herons with a good make-falcon and, while she is in a state of good will from this experience, place her in the mews. If she is flown often without attention to her defective plumage, she will not only be unsuccessful but will lose her desire for hunting; in other words, she will become a coward. There is nothing that makes a falcon a refuser so quickly as frequent failures in her flights. This is not so in the case of crane falcons. It is the falcon who has taken a strong crane fully armed with beak and talons and who has been wounded by it that is most likely to become a coward. But herons are weak prey and seldom injure a falcon when she seizes them. Hence falcons rarely become refusers through the successful capture of a heron.

If an unsuccessful flight is due to a broken pinion or the incomplete moulting of certain feathers, the harm may be remedied by imping, an operation we shall describe later.¹

¹ "Imping"—the insertion of a new vane on an old pinion. In this work Frederick did not, however, reach an extended account of diseases of, or injuries to, falcons.

When a falcon is overconditioned, she must be reduced in weight in the manner explained in the chapter on this subject² and fed on washed meat. Should she return to the falconer because she hopes to be fed on the lure, one remedy is not to take her up at once or feed her. When she is given food, let it not be on the lure and washed meat only.

When the falcon has failed because of insufficient practice with the train, she must not be fed at once when recovered. If a heron is available she must be re-entered to the train that same day. Otherwise herons must be provided and utilized until the hunter's education is completed, especially where it is deficient. She must on no account be flown again at wild herons until her training has been perfected.

The only remedy applicable when the falcon checks at another bird is to lure her at once and to feed her (after some delay) upon washed meat. If she is not recovered at once she may be lost, or she may capture the quarry she last pursued. This latter result would be unfortunate, since she will not again hunt a heron with any eagerness. When she captures the bird at which she has checked, she may feast upon it. If she has not consumed any of it, she must be taken up as soon as possible but not fed at once. If she did make a meal of the checked bird, the falconer may not learn what avian species she has eaten, although he should try to discover it. To do this he may wait until she disgorges the plumage, for she must of necessity eject a casting,³ since in her hunger she will have eaten without distinction both feathers and flesh, and the former she cannot digest. When this casting has been washed and dried, the falconer will be able to identify the bird to which the plumage belongs. This process can be followed with gerfalcons as well as other birds of prey.

² Book IV, chapters xxii (p. 294) and xxvii (p. 305).

³ *Plumata*, "casting," a pellet of refuse feathers and other indigestible matter disgorged by hawks.

There is a second way in which the falconer may discover the kind of bird on which the saker has fed. Let him find the place where she made her repast and inspect the feathers and other remains of her victim. Thus, in one way or another, he will diagnose the species of a particular quarry.

Since a falcon that has gorged in this fashion has probably put on flesh, having partaken with enjoyment and to her full satisfaction of the feast she has provided for herself, before she is flown again at herons place her on a reduced diet until she has acquired her former lean condition.

There is another remedy for the bad habit acquired by a falcon who has checked at another bird and chased it, whether or not she has captured it and whether or not she has fed on it. Even if she fails to seize it she, nevertheless, has adopted the vice of checking. The remedy for this fault consists in taking care that the falcon is not flown again at herons in the locality where there are birds of the species for which she had deserted the heron. Or if there are such birds, they must be driven off before the falcon is slipped, because it is in the nature of a falcon to hunt birds she has once caught and fed upon to her complete satisfaction.

When other birds, especially eagles and vultures, pursue the falcon, causing her to refuse to attack the quarry, care must be taken not to fly her in places these birds frequent, nor during the time they are accustomed to soar in the air, e.g., after the third hour on clear, warm days. Should it be desirable, for certain reasons, to fly falcons at that hour, then the falconer must look about carefully to make sure that there are at hand no large birds that frighten falcons—either those that soar overhead or those that perch in the vicinity.

Furthermore, if the terrain is poor, or the weather bad, a falcon must not be flown at herons, especially when she is a novice; for

at such a time and place she may be lost or at least so affected that she will fly less willingly the next time she is slipped at herons. In case a falcon is flown at a heron in a suitable locality and the quarry flies off to a dangerous position and the falcon starts to follow it, or if she is flown in good weather that changes to bad while she is in the air, she must be recalled to the lure at once and fed, because she has done her best. It is better that she be taken up than be rendered fearful of flying again at herons.

CHAPTER XVIII

ON THE UTILITY OF A MAKE-FALCON

We have shown that a saker, when flown alone at herons, may be thwarted by many obstacles which would not always stand in the way if she were flown with another falcon. There is, indeed, no general remedy nor any relief as efficacious against mischances that block success as to fly the saker with a make-falcon.¹ For a weak falcon who sees another in pursuit of a heron forgets, as it were, her infirmity, and makes a more determined effort than when hunting alone. When a make-falcon, slipped at a heron, overpowers it by stooping and forces it down exhausted, a second falcon, who is so emaciated that she has not the strength to fly high and surmount the heron as her mate has done, is still able to seize the quarry or at least to assist in its capture.

When a falcon's flight plumage is defective, she also will receive relief and assistance by being flown with a make-falcon. Also, if she is fat and reluctant to undertake a solitary venture, her spirit and will are strengthened by observing the flight of another falcon at the heron.

Not only is a falcon that has been incompletely or irregularly educated with the

¹ *falco doctus.*

heron-train encouraged in her flights by a make-falcon, but through the capture of a heron with another's assistance the defective portion of her instruction may be so ameliorated that there will be no need to return her to the train for further practice.

A falcon whose fault is that she is always on the lookout for the lure will lose hope and forget the decoy when she waits on over the falconer if he does not throw it out; and when she sees the make-falcon flying after the heron, she will then follow willingly. This curbs her habit² of always thinking about the lure and will encourage her to fly at the heron. Again, when she is tempted to check at another bird and sees her companion flying at a heron, having a greater inclination to feed on the heron than on the bird she is chasing, she will follow the former, because it is more natural for birds of prey to try to feed upon the quarry of a fellow rapacious bird.

When bad weather and unsuitable ground are present as obstacles to a successful flight, the novice falcon must not be flown. Yet if she is made to hunt with a make-falcon there is less danger of a mischance, for under these conditions a heron is more quickly captured by the make-hawk and the novice together than by a novice alone.

If the obstacle to good flight is the mobbing by other birds, there is less danger that the quarry will escape when the falcon is flown in a cast; for the pursuing birds may attack one falcon and not the other, leaving the second one free to fly after the heron; or even if they attack both falcons, less harm is done to two than to a single bird.

Moreover, when eagles appear it is better to fly a cast than a single falcon, because, although all falcons have a natural fear of the

larger birds of prey, it is possible that one falcon may be less frightened by them than the other; and, if her companion flies off in alarm, the other may remain to pursue the heron and, with luck, capture it; indeed it sometimes happens that the courage of one falcon induces the second to continue her flight.

CHAPTER XIX

ON HOW TO FLY A NOVICE WITH A MAKE-FALCON

We have explained the advantages of flying a novice in a cast with a make-falcon. In order that they may be flown together, whether they are both sakers or one or both of a different species, we must first know that they are willing to co-operate. Two falcons of different species are less likely to fly in a cast than two birds of the same kind; and there is greater risk in attempting the former task, if for no other reason than that one bird will usually be larger than the other. When it is known that they can be flown in a cast, they should be slipped at the quarry in the following order. The make-hawk should fly first, and far enough ahead to reach a point halfway between her starting point and the heron, before the novice is slipped. The latter, seeing her companion ahead, will follow and so be encouraged to attack the heron.

The novice must not be slipped at the same moment as the make-hawk for another reason: When flying close together, they may crab one another because of the hunger to which both are reduced. This will not happen if one is flown well in advance of the other. The falcon that is ahead, since she does not see her companion following her, will reach the heron without attacking the second falcon; and the second falcon cannot seize the first, because she is unable to overtake her in the flight to the heron. When the novice reaches the heron, and sees it has already been attacked,

² The text reads: *eo quod capit usum redeundi ad loyrum et assuescet volare ad ayronem*. To eliminate the apparent contradiction, the translators have inserted before *redeundi* the word *non*, probably omitted by the scribe.

her inclination to strike and feed upon it becomes stronger than her desire to crab her associate.

Moreover, if two falcons were slipped simultaneously at two or more herons, one falcon might choose one heron and her companion a second, so that both herons might escape. If there were only a single heron, the make-falcon might fly at the quarry, while the novice, failing to see her attack the heron, might check and stoop at another bird, and on seeing this the make-falcon also might abandon her pursuit of the heron and attack the easier quarry.

Also, if they are slipped and start their flight together, when they reach the heron they will strike, as it were, a single blow. The heron is less fatigued by this kind of attack than if one blow preceded the other. Because when the first falcon stoops and throws up over the heron before the second arrives and stoops, there is no interval in which the heron, struck by blows in rapid succession, can rise and defend itself by ringing up; and it is thus forced down to earth.

If the novice were slipped to fly at herons before the make-falcon, she might, after starting her flight, check at another bird and so induce the second falcon to follow her example; and even though she chases the heron, the latter is likely to make its escape by lofty flight; and although the make-hawk may rise in pursuit and the novice sees both birds mounting in the sky, she will fail to follow because she is not experienced in such ascents.

And, finally, as it is our purpose to teach the novice by example, it is reasonable to fly the make-hawk first at the heron so that she may carry out the maneuver she is to learn. It is evident, therefore, that a young saker must not be flown either before or at the same time as the experienced heron falcon, but should always follow the latter.

After a make-falcon has been flown with a novice and has captured a heron, the falconer

must go in and take her, if possible, from the quarry by means of a tiring or with meat. The novice should be left on the heron (whose beak is now thrust into the earth) to feed upon it in the usual manner. When she has had her proper allowance of flesh, the young bird must be lifted and her place taken by the make-hawk, who is then permitted to make a meal on the dead heron. If it is seen that the two birds fly so well together that they may be permitted to feed on the quarry at the same time, it is well to allow it. Although it is habitual with falcons to feed in the presence of each other, it is just as well to hold a glove, a hat, or some other object between them while they are eating; indeed, it is good practice to hold them by their jesses to prevent their crabbing.

Although two falcons are better able than a single one to capture a heron, it is still useful to send a trained hunting dog with them, remembering what has been said about the use of hounds in hawking. Moreover, when two falcons capture a heron at a distance, or in a place where it is difficult for a man to gain quick access to them, they will abandon the heron at once when they see a dog coming and will not crab one another; or, if they do, they separate immediately.

A novice should be flown several times with a make-falcon but not so often that she grows accustomed to that form of flight. Exactly how often she is to be flown with a companion we cannot say, as fewer such flights may be enough for one novice than for another and the decision generally depends upon the greater natural endowment of one or the other.

As soon as the novice has taken part in the capture of several herons, is flying at them boldly, and exerts herself to the best of her ability, she may be slipped ahead of the make-falcon and, finally, alone. After this she may be used to teach other falcons to fly at herons as she herself has been taught.

When no make-falcon is available and there are two novices, each of whom the falconer wishes to fly at herons, let him observe which of the two is the more spirited and swifter in flight. This can be done in practice with the train. The better one may take the place of a make-hawk and thus encourage the less-spirited falcon to pursue the quarry.

Although it has been said that the novice may be flown with a group of falcons, we do not agree that it is always wise to fly her with several others. Two, either of the same or of different species, may be flown in a cast if they both consent; but to fly more than two together may be very dangerous.

CHAPTER XX

ON FOUR CHARACTERISTIC MODES OF FLIGHT EXHIBITED BY FALCONS FLOWN AT HERONS

Up to this point we have been discussing the question of teaching falcons to hunt herons without a companion. Now let us see what qualities distinguish the most accomplished of heron falcons, for not all falcons display the same powers when in action. Some develop great speed in mounting high into the air but are not bold in stooping at herons over water. Others, who are not afraid of water, strike fearlessly at quarry actually standing in it but are not able to ring up rapidly. A third group possess both admirable traits—swift upward flight and fearlessness over water; while a fourth class lack these qualities and deserve no praise, for they are useless in heron hawking, inasmuch as a heron attacked by them can exercise successfully both her favorite methods of escape.

Those falcons that possess the two best qualities of heroners¹ are more valuable as hunters than those in either of the other two categories, because the heron has two main methods of defense, viz., to ring up and to

¹ An old name for trained heron falcons.

alight on water, neither of which is an effective guard against the most proficient falcons. As we know, by ringing up high enough a heron may escape from a falcon who is not afraid of water; and it can defend itself against a swift flier who is afraid of water by taking refuge in that element, even though the latter be of small extent.

CHAPTER XXI

ON HERON HAWKING WITH SAKERS SWIFT IN FLIGHT, BUT FEARFUL OF WATERY AREAS

Having described the four types of flight, any one of which a saker falcon may exhibit when she is trained to fly at herons, we must now discuss the various ways of hunting with sakers, taking into account three of the aforesaid modes of flight. As stated, we absolutely reject the fourth type as useless in flying at herons.

Although it is true that sakers, after they are trained, may be flown in many places and in many kinds of weather in which it was impossible to fly them while under instruction and while they were still novices, yet their manner of flight varies greatly, and it is, therefore, desirable when setting out to hunt herons to take this fact into special consideration, and to study prevailing topographical features and weather conditions so as properly to regulate one's own method of procedure.

Those falcons that are swift fliers but fear watery areas should be flown in places where there are shallow waters such as the overflow from streams, pools of rain water, and marshy ground.¹ A heron is easily driven from such localities; and although it is habitual for the bird to ring up as soon as it has lost its watery protection in order to escape the blows of the falcon, nevertheless if the latter is swift

¹ *Loca parvarum aquarum sicut flumina rivorum et loca collecta aquarum pluviarium pantanarum.* For the last word, compare the Italian *pantano*, "fen," "bog," "slough."

enough the heron cannot escape on the wing and, deprived of an aqueous refuge, is soon captured. The farther the heron is driven from expanses of water, either in vertical or in horizontal flight, the more boldly will the falcon stoop and bind to her prey. For this reason it is desirable, when putting up a heron for a powerful but timid falcon, that the expulsion of the quarry be carried out suddenly and forcefully. Whether the task is performed by a man or a dog does not matter, so long as the heron is driven far from pond or stream. The oftener a falcon captures a heron the greater becomes her desire to hunt, and her sense of efficiency increases with exercise. As herons are usually found standing in water or near it, the more often a falcon hunts them the quicker will she become accustomed to the presence of water and, therefore, less afraid of it.

Wind blowing along the river is unfavorable to the success of hunting falcons who fear the water, because the breeze makes it difficult to drive the heron from the aqueous surface over which the falcon is afraid to attack and in which the heron finds an adequate refuge. One method of proceeding against this state of affairs is to drive the heron as hard as possible into the wind and when, after the quarry has risen, it turns and drifts down wind past the assistant who forced it up, let him ride fast, moving away from the water, until he has outstripped the heron. Then he should [return to the shore and] send it up once more against the breeze. This act should be repeated until the falcon has either captured the heron or given up the chase.

If the wind blows across the stream (even though the river is wide and the falcon fears the water), the problem is not as difficult as when the direction of the wind is along the river, over which it may blow strongly;² because, when the falcon attacks, if she takes courage and strikes the heron, the wind will help to drive the bird away from the water.

The falconer's (two) assistants who are near the river should separate, so that one is on the shore above and the other below the heron. When one aid has raised the heron, driving it toward his companion, it soon flies away from the water and, if the falcon attacks, is unable to return, because the wind is contrary.

When the area is a collecting ground for rain water, is shallow, is such that a man may easily gain access to it (to put up the heron), and there is no wind, the falcon may be flown in the following manner: The heron is first made to rise and allowed to fly so far from the water that it can have little hope of returning to it. Then the falcon is slipped. If, in fear of the falcon, the heron manages to return to the water, the bird must be driven off forcefully. In such a locality, a falcon may also be flown when the wind is blowing, no matter what its direction, provided she is directed against it. This is an important proviso, since, as she makes her attack, wind and man combine to drive the heron quickly away from the pool. Let it not be forgotten that there are localities where the watery surface is so wide that it would be unwise to fly a falcon without the help of a breeze.

When the body of water, either lake or pond, is so large that a falcon does not dare (because of her timidity) to attack a heron in it, if there is wind, make the heron rise after stationing men around the water's edge to prevent it from settling there again. Since a heron is not a good swimmer and is prevented from landing on the shore, it must fly away from the pond. If, on leaving the water behind, the heron flies against the wind, do not slip the falcon until it is so far from its aqueous refuge that it has no hope of returning to it. The direction of the wind will assist the quarry to return to the water, but it may be expected to try to find another watery sanctuary. If the heron flies back with the

² *quam vis pervasit.*

wind or across it, the falcon may be sent after it; but if there is no wind, put up the heron and wait until it is so far away that it will not try to return. Then slip the falcon, if she is one that can be flown at such a distance; or, if this cannot be done, wait until the heron seeks some other pond, where it is possible to fly her. This method of allowing the heron to fly some distance from the water is inapplicable in the case of rivers, for these streams are long and a heron that is sent up will simply move from one point on the bank to another. The bird naturally follows the course of the stream and does not of her own accord go far from this water.

When, however, the aqueous body is so extensive that the falcon is afraid of attacking a heron over it, she may yet be flown if one adopts a certain ruse. Take another falcon that is not a swift flier but has no fear of stooping at herons over large bodies of water, and use her to help capture the heron. Stand down wind, holding both the swifter falcon and the second that is fearless over water. Let the latter stoop at the heron and, when the quarry has been forced away from the water and is being attacked by its pursuer in a wind that is unfavorable to it, it will be forced to fly down wind and leave the water behind it. The falconer holding the swift-flying falcon, when he has seen the heron leave the water, must slip his bird at the quarry. Then the heron, now aware that it has lost contact with its asylum, will ring up. The higher it flies the farther it will be carried from the water, since the wind is stronger at the higher altitude, and the heron is carried off a great distance in a horizontal as well as a vertical direction. When this has been accomplished, the swift-flying falcon (having now no water to fear) can surmount and bind to the heron. By these maneuvers the heron can be secured, having been barred from its watery shelter and thus not lost to the falconer by gaining a sure refuge.

CHAPTER XXII

ON HERON HAWKING WITH SAKERS
SLOW IN FLIGHT BUT HAVING
NO FEAR OF WATER

We have discussed the saker falcon that though swift in flight is afraid of watery expanses. Now let us consider the saker that is not swift but has no fear of water. It is necessary in maneuvering with such a falcon to take into consideration its deficiency in flying ability. It was essential, as we have shown, in the case of the first class of falcons, to prevent the heron from escaping by taking refuge in water. Under identical conditions of environment and weather (in the present instance) our aim will be to forestall any attempt of the heron to ring up and, by this means alone, evade the slow-moving falcon.

If a stream is small the heron should be put up in the same manner as in the case of the novice, with or without a dog and whether or not a wind is blowing. If, however, the river is wide, the heron must be sprung with greater force than over a small body of water; for when the prey knows it has a good chance of returning to an aqueous refuge it will not willingly ring up, because herons always prefer to find sanctuary in large bodies of water. The more extensive the asylum the more swiftly must an effort be made to put up the heron from the water; otherwise the falcon waiting on will become exhausted and lose hope. She may even return to the falconer, or alight somewhere else. If it is seen that the heron is starting to soar, the falconer must withdraw at once to such a distance from the water's edge that his presence will not make the heron afraid to return to the river. In this way she is kept flying at a low pitch. When the wind blows across the river, it is not necessary to use as much force in putting up the heron as when it blows along the course of the stream.¹

¹ The aim is to keep the quarry above the water.

As soon as the heron has been made to rise and it is apparent that it is going to soar high up, because of the presence of the falconer or because it is carried off by the wind and has lost hope of returning to the water, the falconer must withdraw from the river's edge. But if the heron takes refuge in the water in fear of the falcon, he must go in at once and drive it away. This must also be done if the heron is struck into the water by the falcon. Under such conditions a saker that is fearless of water will either kill a heron by stooping over it or so weaken it that it can be captured by a man or a dog; or, if it leaves the river, it will be unable to ring up because of its exhaustion or injuries. To repeat, a heron must be put up with considerable force from a wide river or other large body of water over which a falcon can fly.

A falcon must be flown at herons under weather and topographical conditions adapted to her ability as a hunter, and the various maneuvers employed to assist her must be determined by her skill, taking into account her speed and courage (or lack of it) over the water, in both of which qualities some sakers excel others.

No matter what exceptions may be made in the foregoing rules, two are unalterable: the falcon must be slipped against the wind, and the heron put up into it.

CHAPTER XXIII

ON HERON HAWKING WITH SAKERS THAT ARE BOTH SWIFT AND FEARLESS

The maneuvers that are appropriate for hawking in various kinds of weather and localities have just been discussed, as they relate to falcons who are swift fliers but fear water and to those who are slow but fearless. We must now consider the saker who is both swift and fearless, and because she possesses both

these fine qualities we can describe more fully and completely all forms of her flight at herons.¹ This was not possible in the case of the first two classes of falcons, for neither of them is competent to carry out every kind of maneuver. The heron may be put up for the falcon who has both good characteristics in any manner desired, either as was recommended for the swift flier or in the manner used for the falcon who has no fear of water, provided only that the locality is otherwise suitable for flying falcons. As the heron places her chief trust in a sanctuary consisting of a body of water, one has only to see that she does not escape by ringing up to great heights.

CHAPTER XXIV

ON THE ENVIRONMENT DESIRABLE AND ON THE PRECAUTIONS TO BE OBSERVED WHEN FLYING A SAKER THAT IS BOTH SLOW AND TIMID OVER WATER

We have said of the saker who has neither of the good qualities desirable in a heron falcon (i.e., one who fears the water and is a slow flier) that she is useless for capturing herons; but as it sometimes happens that no other kind of falcon is available we must detail the circumstances under which, and tell by what procedures, such an unsatisfactory falcon may be made use of in heron hawking. A bird with the defects in question is able to do very little against a heron unless she is given proper assistance, and this must be supplied by good weather, favorable terrain, and skillful manipulation of her flights. For these birds, the very best ground and weather should be chosen by the falconer. If a hill is close by, he should climb it and from there slip the saker. His assistant, who remains below, must not put up the heron until he has, by

¹ Book V, chapters xxv to xxvii, pp. 346-50.

gesture or voice, received the falconer's signal from the hill.¹ To direct the heron into the wind the assistant must loose the accompanying hound, while he himself remains down wind. The falconer will then slip the falcon, and as often as she drives the heron to the water the dog must send it up. If the wind blows parallel with the riverbank and carries the heron down wind, beyond the assistant who put her up, the latter must follow down wind at once and place himself below the heron and again allow the dog to send up the quarry. If the hound delays in performing his duty, let the assistant himself go in quietly and drive the prey into the wind; and he should repeat this act each time the bird descends into the water. If he has no dog, or the dog fails to approach the heron, the assistant must himself do the work, as we have directed.

When the wind blows across the river the dog should rout out the heron, but gently, lest the wind carry it swiftly from the shore, causing it to ring up and be lost to the slow-moving falcon. The falconer must stand on the hillside to slip his saker, because this station furnishes his hawk the greater momentum to throw up and to stoop a second time. If the falcon takes the heron, the falconer must go in and assist her, following the instructions we have given. These last remarks (with reference to unsatisfactory falcons) apply only to the hawking of herons found in or near shallow pools of rain water.

CHAPTER XXV

ON SPECIAL HAZARDS CAUSED BY WIND AND UNFAVORABLE TER- RAIN WHEN FLYING FALCONS AT HERONS ON THE RIVER

Not all rivers offer the same satisfactory environment for flying falcons—some being favorable in certain parts of their course and

¹ *nisi voce vel signo inuingat sibi.*

unfavorable in other sections. Some rivers flow through groves, others out of or into lakes; some become lost in, or flow from, reed beds and marshes or other inaccessible places; while still others both rise from and terminate in localities that are unsatisfactory. These last are of two types: i.e., the hazardous areas, through which streams run, may be at (first) a short or (second) a long distance from each other. As neither the same sort of weather nor a single procedure may be suitable in both of these localities, we must describe the various maneuvers that are proper (or not) at a given place and under certain weather conditions.

When a river is propitious for flying falcons in some parts of its course and poor in others, and a heron is discovered standing near an unfavorable point, with the breeze blowing toward it, the falcon positively must not be flown, because the wind will carry the heron quickly into the disadvantageous position. The quarry must first be made to move to a better region. While this is being done, no one¹ should stand near this more suitable position; the entire party must withdraw toward the point of danger, and an assistant should ride quietly between that hazard and the heron. He must not proceed as if with the intention of driving up the prey but must simply by the mere fact of his approach make the heron rise and move farther from the place that is inconvenient to the hunting falcon. If the heron flies far enough the first time to permit of launching the saker, let the falconer slip her; but if not, he should make the heron move farther away until it has reached a favorable position.

When the wind is blowing from across the river, or when it comes directly toward the heron from the unfavorable area we have mentioned, the falcon may be slipped at the

¹ Bologna Codex, fol. 119^v, col. 1: *Non stet aliquis in loco (in)conuenienti.* The sense of the passage requires the omission of *in*. The Valencia and Mazarine codices give the same reading.

heron. In the case of a cross wind the heron must be farther from the obstruction than when the breeze blows directly from the danger point, if one wishes to fly the falcon. If the heron is not as far away as it ought to be, it must be made to move on (as before); and when it has reached a proper distance, the falcon may be slipped. It is better to hawk a heron in a cross wind² than in one blowing from an unfavorable region, because when a gale blows across the river and the heron has been moved far enough from the point of danger there remains nothing more to do but to drive the quarry from the water's edge, to which end the breeze and the efforts of man combine. A stronger wind is required to drive herons from a wide river than from a small stream; also a vigorous breeze helps to expel herons from other large bodies of water.

If one wishes to fly a falcon at a heron near a hazardous area and the wind is blowing from that direction, the falconer, bearing the falcon, must approach the quarry as near as he can and slip his hunter against the wind, so that she will take the heron before it reaches a protecting asylum. To accomplish this, the assistant who puts up the heron must take his stand between the quarry and any possible refuge. In this case, in spite of what has been said about always driving the heron against the wind, the quarry must be raised with the wind until it has flown away from the danger spot; then, when it has reached a sufficient distance, a hound may be sent to raise it well against the wind. But even if a dog is available when the heron is standing near an unfavorable locality from which the wind is blowing, he must not be trusted to put up the heron, for he cannot distinguish the proper direction of that operation. Speaking generally, however, where the heron has to be frequently flushed, and where a man is prevented from performing this task, a trained dog may be very useful.

² From across the river, not along the stream.

When the river flows from one to another of two hazardous areas that are only a short distance apart, and there is little or no wind to raise the heron away from the water, conditions forbid any flight of the falcon. If, however, there is a cross wind strong enough to force the heron from the river, and the bird is standing about halfway between two unfavorable points, then the falcon may be slipped. This cannot be done with success when the wind blows directly from one unfavorable locality toward the other.

Whenever the distance along the river between the danger points is great, the falconer must first consider whether the heron is standing midway between them or nearer one end of the stretch than the other. If it is near the middle and there is no breeze, or the wind is weak (no matter whether it blows crosswise or comes from one of the dangerous areas), a falcon may be sent in pursuit of the heron. But if the wind is strong and is blowing along the stream, the heron will probably take refuge in the hazardous area into which the wind drives it. The quarry will then be able to find security more rapidly in a refuge that is down wind, thus reducing the chances of a successful flight on the part of the falcon. Nevertheless, if the heron is raised against the wind, in such a way as to send it far enough from the obstruction that is below the wind to permit the falcon to capture it before it changes its course and returns to that refuge, a successful flight will be possible. But if the heron is nearer one obstacle than another and there is no wind, the bird should be made to move to a point halfway between them before the falcon is slipped. When there is a wind, one must take into account its direction and proceed as in the case of the river where there is only one perilous area. The heron, however, must always be moved away from the refuge below the wind. The distance that is requisite for flying a falcon between a safe area and an unsafe one cannot be estimated with-

out first knowing the flying prowess of the particular falcon.

Even though the river near which a heron has taken its stand is uniformly good throughout its course, the falcon must not be flown when there are close at hand such hazards as ponds, pools, marshes, or groves lying near its bank, on one side only, into which a heron standing in the river near such a possible refuge may be carried by wind blowing that way. The quarry must, in that event, be flushed and forced to move either up or down stream, whichever is easier, until it has reached a point far from the protecting sanctuary. Then, if the wind drives it from the river it will not be carried directly into the refuge. In case the wind blows away from the marsh or other watery deposit, or even along the river, conditions are favorable for a flight at herons. However, where there are hazardous areas on both sides of the stream it is better to have a wind parallel with its course. If there is a cross wind the heron must be driven far from that section of the river, either up or down stream, before the falcon is allowed to fly. Finally, if there are too many obstructions or one so large and of such a nature that none of the foregoing precautions is operative, then positively no flight should be attempted.

CHAPTER XXVI

ON HOW TO TEST THE FLYING POWERS OF A FINE FALCON

When one has an apparently good falcon, whose qualities and speed he desires to test, the falconer may make the trial in the following manner: If possible, find a heron in a small pond, or river, whose size gives the quarry little promise of safety. Using a second, slow-flying falcon, put up the heron forcefully and slip the falcon (the slow one). The heron, seeing itself pursued by the fal-

con and deprived of a watery refuge (since the stream or pond is too small), will ring up and sometimes, in order to rise faster and soar more lightly, it may evacuate the contents of its digestive tract. In climbing, the bird both mutes and disgorges the fish or other contents of the gizzard; and it has been proved that whenever it does this a heron actually mounts higher than it otherwise would. When the falcon that has been slipped sees the heron mounting, she will follow or ring up with it. When it is evident that the heron has soared as high in the air as it is possible to slip a falcon after it, then the good falcon (whose powers of flight are to be tested) may be sent up. This, however, can be done only if it is known that the two falcons can be flown in a cast. If not, the first saker must be lured and recovered before the second is released. When there is wind, care must be taken that the man flying the second falcon is standing down wind; how far will depend upon the strength of the breeze. The flying powers of the hunter to be tested will be regarded as superior if, after the slow flier has already forced the heron to a high pitch, the former falcon is able to outfly and stoop over the quarry, seizing or forcing it to earth. At this time it is very desirable that the horsemen who are present to give aid should not stand still. They must gallop as quickly as possible with the wind, for it is in the nature of the heron (or of any other bird on the wing) to escape by mounting on the breeze. For this reason it is always well for those who wish to help the heron falcon to keep well below the wind. In a very strong breeze these men should be stationed a long distance down wind before the falcon is slipped, to make it possible for them to lend assistance. Moreover, when the wind is strong, the falconer should be very sure that there is no hazardous locality or other possible sanctuary down wind (even though it be at a distance) where the heron may take refuge.

CHAPTER XXVII

ON FLYING SAKERS AT A HERON
ON PASSAGE

So far we have been discussing the status of herons found standing near water, the manner of putting them up, when to slip the falcon, and other matters pertaining to successful flights at quarry. Now we must decide how a falcon should be sent in pursuit of a heron flying across country.¹ A falconer who wishes to do this must first become acquainted with the countryside where the flight is to be made, particularly to avoid flying at a heron near some hazard where it can take refuge.

When there is no wind, and the heron is flying toward the falconer, he must not slip his saker until the quarry has passed overhead. Then let the falconer observe whether the heron is flying high or low; if high, allow it to move off some distance before slipping the falcon; but if it is flying low, she may be sent up sooner. Should the heron be passing directly in front of, behind, or at the side of the falconer, he must take note of its pitch (as before) and regulate the moment of slipping the falcon accordingly. When the heron is passing at some distance, the falcon may be slipped across its path before it has passed, whether it be going along high up or low down.

The proper moment for slipping a falcon at a heron when there is wind blowing may be determined by the following factors: Let us assume that a heron, flying in the wind, approaches the falconer from the front, passes over his head and onward, or flies in the reverse direction. Another alternative is presented when it crosses before him from one side to the other or behind him in the same way; or, again, it may pass by on one side or the other.

When the heron advances directly toward

him, the falconer must note the exact course of the wind. If it blows in the direction the heron is moving, he must not slip the falcon before the former has passed over him, because that would be to slip her in the face of the quarry, which is contrary to good practice, since no rapacious bird will attack her prey from the front, no matter how small the quarry may be. Nor should he slip his falcon behind the heron, for then he would be sending her down wind, and this procedure, also, is against the rules. Hawks do not leave the fist properly when sent down wind, nor do they mount so well as when flown against a breeze—a prerequisite in heron hawking. Therefore, when the falconer who is to fly his bird sees the heron coming in this manner (especially if he sights it from a distance), he should at once turn and ride away from the course of the heron's flight, so that it will have to pass to one side of him. When it has reached a point opposite him, he can slip the falcon, who now will be headed half into the wind and yet will not be directed into the face of the heron but will approach it sideways. After slipping the falcon he must follow quickly, to give aid.

On the other hand, if the wind is against a heron coming directly toward the falconer, he must wait until it has passed over to slip the falcon. There are two objections to letting her go sooner: she would then be flying directly in the face of the heron and with the wind; but when the quarry has passed over, the falcon may be flown against the wind and behind the heron. There is no need in this case for the falconer to ride off his course.

When the heron is flying in the direction of the falconer and the wind blows from right to left, or from left to right, and the falconer sees the heron from a distance, he should turn from his path and move down wind. The falcon must be slipped before the heron has passed, and in time to permit her to reach the quarry while she is still flying

¹ Or, as the falconer says, "on passage."

against the wind. If she starts too soon she will fly into the face of the heron; if too late, she will be at a disadvantage when she overtakes the heron, since she will then be flying down wind.

When the flight of the heron is in the opposite direction, i.e., when it is moving forward from behind him, the falconer must, before slipping his falcon, note the direction of the wind, to decide whether it is blowing with or against the heron or from left to right across the latter's line of flight. He must then turn and slip the falcon, governing his acts by the rules laid down in the previous paragraphs, especially taking care never to fly the falcon into the face of the heron, nor with the wind.

When the heron is flying from right to left, or in the reverse direction across the path in front of the falconer,² and the breeze is blowing in the same direction, the falconer must wait for the heron to approach. Before it reaches him, or crosses his path, he should turn (so that the heron may be seen by the falcon) and let her fly across the wind, in time to engage the heron with the wind still coming against her side. If the wind is blowing toward the heron, the falconer should allow the quarry to fly a little distance past him, and then slip the falcon, so that when she overtakes her prey she will be moving behind it and directly against the wind. If the breeze is blowing either toward or away from the falconer (across the heron's line of flight), he must, in the first instance, wait until the heron approaches and then slip the falcon just before it passes, so that she is flying directly into the wind when she overtakes the heron. In the second case, when the wind blows away from the falconer, he must show the heron to the falcon, turn about, and toss her against the wind but not toward the heron, for that

² All three codices read: *ante faciem ayronis*—a scribal error demonstrating the close relationship of the three manuscripts. Bologna, fol. 121, col. 2; Mazarine Codex; p. 497; and Valencia MS., fol. 198^r.

last act would be tantamount to throwing her with the wind.

There is still another mode of slipping the falcon with reference to the wind, whether it blows either from right to left or the reverse (across the heron's line of flight); and that is when the heron is passing behind the falconer from right to left or in the opposite direction. In this event the falconer must simply turn around so that the quarry passes in front of him. Now, remembering what has already been said, let him slip the falcon either into the wind or at least across it. Should the heron be flying with the wind, the falconer must turn so that the heron is passing in front of him, and then he must follow the directions just given.

When a heron is coming toward the falconer, the most unfavorable wind is one that blows in his face; for even though he directs the falcon across the wind, this act cannot be performed in such a manner that she is not made to fly with the wind when she overtakes the heron. When the heron is crossing in front of the falconer, the least favorable wind is one that blows from the falconer toward the quarry, because, although he turns and slips the falcon against the wind she must nevertheless fly at the heron with the wind.

The question of how soon or how late to slip the falcon when the distance to the heron is long (or short) must be decided by the character of the individual saker or, indeed, of any other species of falcon.

CHAPTER XXVIII

ON THE FLIGHT OF EYASES ENTERED TO HERONS

We have now completed our discussion of flights at herons, taking into consideration all the conditions under which they are found and the methods to be applied to the various combinations of circumstances that are presented.

Let us now turn to a discussion of the various characteristics displayed by falcons when hawking herons, giving special attention to eyases and branchers as a class and as individuals, so that we may discover what mode of flight is best suited to each falcon.

Eyases nearly all fly at herons in the following manner: Whenever they are slipped at a heron, from the time they are entered to that quarry, they wing their way close to the ground but, when they come below the flying heron, they rise toward it and sometimes strike at the quarry in their ascent. If they are not able to attack it as they climb, they ring up until they are on a level with the heron; they start their evolutions down wind, and when they reach the altitude of the heron they fly straight at it, to strike. This act is, however, dangerous for a young falcon; for when she turns for the assault the heron may thrust out its beak at her, or the eyas herself, in striking, may fly against and be stabbed by the mandibles of the prey. Moreover, young falcons when they have turned to strike the quarry (whether or not they succeed) do not throw up in order to stoop again but pass straight on. This manner of flight is objectionable because as soon as the eyas has passed the heron, the latter follows her closely, so that she is unable to turn and strike a second time, however eager she may be to do so. Moreover, as she is no higher than the heron, she cannot execute an effective stoop. Also, if the eyas starts to circle up with the wind, followed by the heron, she can never soar so high that the heron is not close behind her. The heron is a swift flier when going down wind; hence it is always more difficult, under these conditions, for the falcon to turn around and attack the foe. There is, moreover, the additional disadvantage to be encountered, that a heron flying with the wind can quickly take refuge in some locality that impedes the falcon's flight. Moreover, the progress of the quarry is so swift that the men placed to give assistance to

the falcon are unable to reach her in time. It happens also that when the young falcon is unable to attain the heron's pitch she will merely circle about in a vain attempt to rise above her prey and to repeat her assault. As we have said, this is a dangerous proceeding; in fact, few unmoulted eyases can ring up well, because their plumage is not well developed like that of branchers. They have not had the benefit of the invigorating nourishment the latter have received from their parents. Although their loins (*renes*) are just as strong, these novices have had no experience in flying wild and have not been educated as thoroughly as branchers, who were older than they when captured.

As a rule the eyas who has failed to strike or seize the heron while mounting does not attempt to go higher; but when the heron starts down, either because it is weak and cannot ring up higher or because it hopes to take refuge in some body of water, the eyas strikes hard. But should the heron start to climb, the former will not follow but will allow the quarry to escape. These observations hold true of eyases of all species.

CHAPTER XXIX

ON THE FLIGHT OF BRANCHERS ENTERED TO HERONS

Branchers display two kinds of flight. In the first, similar to that of eyases, their performances with herons are more effective than those of falcons taken as nestlings and are executed with greater ease. Such young falcons are not, however, greatly to be praised. To the second class belongs the brancher that as soon as she leaves the falconer's fist starts to climb after the heron and is not content with attaining the heron's pitch but mounts higher and soars above it. Here she opens wide her wings, expands her tail, and sails overhead, watching for the best opportunity

to stoop. This she does not dare to do until she has climbed so high above the heron that her downward plunge will enable her to throw up easily, leaving the heron well beneath her. Although this manner of attack has much to recommend it, nevertheless it has this defect—that branchers are sometimes afraid to plunge well downward in their stoop, although this happens only when they feel weak or do not trust their speed. Such a hesitation in the young falcon's headlong descent may afford the heron an opportunity to take refuge in some shelter where it is safe from attack; or else such a flight may¹ so exhaust the falcon as to cause her to abandon the attempt to strike down the heron.

Among those branchers that mount straight up from the fist and are not content with merely attaining the level of the heron but soar higher to surmount it, there are those that, when there is wind and it is necessary for them to ascend in circles, begin their upward course against the wind, leaving behind them the heron, which remains down wind. They easily gain the higher pitch, since the breeze hinders them less than it does the quarry. When a young falcon has climbed above the quarry and turns back toward it, she spreads her wings and tail and soars like other branchers high in the air until she sees how best to strike. No matter whether a brancher stoops with or against the wind, she turns as she throws up and rises against it. This last type of falcon stoops fearlessly and throws up boldly. Her method of flight is worthy of the highest praise, because, although the heron may follow close behind her when she flies against the wind and away from her quarry (in order to mount above it), the latter can never come so near her that it is not at a lower level. Also the falcon gradually moves farther and farther away from the heron, because the wind blowing against them

is a greater hindrance to the heron than it is to the falcon. For this reason, this variety of falcon, when she has gone some distance and is higher than the quarry, can easily and skillfully turn around and strike the heron in any manner that suits her. In this mode of flight there is no danger to the falcon from the heron's beak, for when the heron is struck from above it rarely if ever thrusts out its mandibles to wound the pursuer as it does when attacked on the same level.

Although it is a fact that many falcons (branchers) do not possess this excellent manner of flight, nevertheless when they do make frequent attempts they gradually acquire proficiency in the art of hunting and choose by experience those methods that are the most successful.

CHAPTER XXX

ON THE SPECIAL ATTENTION TO BE GIVEN INDIVIDUAL FALCONS

The foregoing describes the proper methods of teaching sakers to hunt herons. The same processes may also be used for the instruction of other species of falcons, but with the difference that all falcons that are naturally more courageous and stronger than sakers can be taught more easily and with less attention to details. This is true not only of species in general; it applies to individuals as well. The stronger and bolder members of a species are taught more quickly and with less effort than the rest of their class to fly to the train and to perform other necessary operations, whereas more timid individuals require greater attention, as well as more prolonged and more thorough training. All falcons that are less courageous than sakers are more difficult to teach; they call for additional care in flying them to the train and in performing other necessary evolutions. This is true both of species and of individuals of a

¹ *n* poterit; *n* is emended to *v*—vero.

given species, the more timid of whom require careful practice in the various steps of the train in dealing with standing, walking, and flying herons. In their case, also, special attention must be given to the proper order of their education and to bribing these different birds with good meat while on the train. Special encouragement is required chiefly because they are difficult to enter to the train and it is not easy to put them through the necessary stages of instruction to make them good heroners.

One should not be discouraged if certain falcons are found to be unusually averse at first to enter to the train, since it sometimes happens that these very birds turn out better flyers in the end than those that from the beginning take readily to train practice. In the same way certain falcons fly well when first entered to herons and others less well; but one must not lose heart over poor beginners, for they may, as stated, eventually turn out to be better performers than some novices that begin well but fall by the way.

Finally, in spite of the fact that we have designated the saker as the special heron falcon, she can also be taught to fly at all birds that are hawked by any other species of falcon.

CHAPTER XXXI

ON HOW OTHER SPECIES OF FALCONS COMPARE WITH THE SAKER AND WITH EACH OTHER AS HUNTERS OF HERONS

We have discussed the training of the saker for heron hawking, and have noted that she is better at this form of the chase than at other sport, also that most falcons may be taught to fly at herons. As each raptorial species has its particular method of flight, we must now consider how these birds compare with sakers and with each other as heron hunters.

When flying at herons, gerfalcons resemble sakers in the following respects: They are

taught to fly in the same manner, by using the train and other exercises and by giving attention to the particular requirements of each bird. They also have the same manner of ringing up and soaring above the heron, as well as of stooping and of throwing up for repeated attacks. Neither the gerfalcon nor the saker readily checks at another bird. They both may be slipped at herons flying either high or at a distance but are afraid of a hound running to their assistance. Few individuals of either species can be flown in a cast with one either of its own or of another species. Branchers belonging to the species of gerfalcons, lanners, and sakers are more afraid of dogs than are those belonging to other species.

Gerfalcons flown at herons will prove to be stronger, swifter, and bolder than sakers; and they perform with greater speed such maneuvers as flying directly at the heron, rising above it, repeated stooping and throwing up, soaring in spirals, and all other movements necessary to capture the quarry. Weather affects gerfalcons less than it does sakers, and the former fly upward and soar more steadily against the wind. They are able also to make shorter turns. A gale, however, carries sakers farther than it does gerfalcons, because the former have longer and better flight feathers and smaller bodies. They are also lighter in relation to their size than the gerfalcon. Gerfalcons are not weaker after their moult (unless they develop defective feathers), whereas some sakers, even when their plumage is good, after shedding their plumes are found to be less reliable hunters than they were before moulting.

Peregrines resemble sakers in the instruction they require and in their manner of flying at herons. They can likewise be flown successfully at herons on passage at a distance. The peregrine is swifter and checks oftener at other birds than does the saker. Although a few (rare) sakers take herons without be-

ing entered to the train, peregrines are often found that will do this. Peregrines do not climb to a high pitch as readily as sakers, and they are less persistent in their pursuit of herons. They are better hunters than sakers in bad weather, but when a peregrine has surmounted a heron she does not stoop and rebound again as often as the saker does. The peregrine is more inclined to strike the heron when flying straight at it and on the same level. Sakers, on the other hand, prefer to stoop from above. Sakers are often less skillful and slower after the moult, while this is not true of peregrines.

The brancher of the true noble falcon affords the same comparison with the saker as does the peregrine, who is of the same species. The differences between this brancher and that of the peregrine will be discussed when we compare the two types.

Noble eyases are taught and flown in the same way as sakers. When hunting herons they do not check at other birds unless they have been entered to them previously. Bad weather is harmful to both falcons. The noble eyas is more tractable when entered to the train and more quickly put through its various stages. She is, however, rarely successful in taking a heron when slipped at one flying in the distance, and is at times more inclined to check at other birds than is a saker.¹ The majority of noble eyases fly near the ground when slipped at a flying heron until, when beneath it, they rise to seize their prey. They do not attempt to get above it if they fail to take it, nor are they persistent in their flight. Sakers attempt more frequently to rise above the quarry and do not quickly abandon the chase when flown at herons. Eyases of the noble falcon have very little fear of dogs.

Lanners and sakers are taught to fly at herons by the same means, and they have the same manner of flight. Lanners are less likely

¹ Frederick says that neither falcon checks easily when flown at cranes (Book IV, chapter xxix, p. 310).

than sakers to check at other birds; and bad weather affects both species adversely. They readily become shirkers and easily develop other depraved habits. Sore lanners as well as unmoulted sakers are often swifter fliers than intermewed birds of the same species. Branchers of both species are fearful of dogs running to their assistance. Both falcons readily become cowards, but the lanner has less courage than the saker and therefore requires more exercise with the train. The former does not perform the various maneuvers in flights at herons as vigorously and boldly as the saker. Although both sakers and lanners are incommoded by adverse weather, the latter are far more seriously affected by it. The less brave lanner becomes a shirker and develops bad habits more easily than the saker.

The peregrine and the gerfalcon are alike in that they can both be taught to fly at herons, using the train and other educational devices. The peregrine approaches the larger species in swiftness and courage, and both are little troubled (in flying) by bad weather, although the peregrine is a weaker bird and consequently less powerful in flight than the gerfalcon. The smaller falcon is more inclined to check at other birds; she does not climb so well, stoop so often, or rise after the stoop as well as the gerfalcon. Peregrines are more easily entered to the train, and more of them will quickly take a heron without previous practice with that device than do gerfalcons.

The resemblances and differences between the brancher of the noble falcon and the gerfalcon are the same as between the peregrine and that fine species. The difference between the noble brancher and the peregrine will be explained in the paragraph covering their comparison.

Eyases (i.e., novices taken from the nest) of the noble falcon resemble the same class of gerfalcon in that they may be trained by the same means—by the use of the train and other

facilities—and they are flown at the heron in the same manner. They² excel the gerfalcon in the serenity and courage they show when entered to the train and in the rapidity with which they complete their education. Gerfalcons fly better at herons on the wing than do noble nestlings. These latter fly close to the ground until they are beneath the quarry; then they rise to seize it. When they are unsuccessful they seldom attempt to soar above the heron, as the gerfalcon will always do. The eyas prefers to seize the heron directly rather than stoop over her. But when she does stoop, a nestling (of the noble species) rarely throws up or pursues the heron for long; indeed, she often checks at other birds. She has little fear of dogs coming to assist her; she will fly in a cast with others of her own species or of a different one; and she does not crab in the air or on the quarry; in all these respects she differs from the gerfalcon.

The lanner and the gerfalcon are trained in the same manner, and fly at herons in the same fashion. They are taught through lessons with the train. Both of them stoop and rebound well after this instruction. Lanners flying at herons do not often check at other birds, any more than do gerfalcons. They require more education with the train, as they are less courageous than the larger gerfalcon. They are also less powerful and swift, although they fly at herons in almost the same manner as the gerfalcon, climbing above the quarry and maneuvering in the same fashion. They suffer more from adverse weather, more easily become shirkers and more readily acquire other bad habits. Many lanners are poorer fliers after the moult, whereas most gerfalcons subsequently improve, especially in their powers of flight.

Peregrines and noble branchers are taught in the same manner to fly at herons (by use

of the train and other means), and many of both species will capture herons without taking lessons in the train. They both are inclined to check at other birds, and each will fly with another of its own kind or of a different species without crabbing in flight or on the quarry. The noble brancher is not so swift, nor so bold, nor so strong as the peregrine, and is more easily affected by bad weather. The former falcon has a greater fear of stooping over water. She will also check at other birds (when flown at herons) more quickly than a peregrine, while the latter is more intelligent in that she more frequently flies at herons without previous practice with a train.

The same methods are to be employed in teaching both peregrines and noble eyases to fly at herons, using the train and other suitable devices; they are slipped in the same manner, and both will fly in a cast with others. Many of both types will take herons without previous train practice. The peregrine may be flown at herons passing at a distance and high in the air with greater success than follows the efforts of eyases. The noble eyas keeps near the ground until she is close under the flying heron, and then rises to seize it. If she fails in her first attempt to capture the heron she will seldom attempt to soar above it, as is customary with peregrines. An eyas (of the noble species) tries first to capture the heron before she strikes it. This a peregrine will not do. The nestling harasses the heron less, and is less inclined to check when in pursuit of her legitimate quarry.

The lanner and peregrine falcons are alike in the kind of instruction they need, particularly with the heron train. They are slipped at herons in the same manner. The lanner, however, is the more timid and gives less satisfaction when entered to the train, and requires more careful handling. She is also slower in flight. Whereas many peregrines take herons without train practice, there are practically no lanners who will do this. Bad weather is more

² This passage in the text is somewhat confused, since the scribe has been careless in his use of the words *nidarii*, *ramagii*, and *gerfalconi*.

harmful in its effects upon lanners than upon peregrines. Lanners do not often check at other birds; they stoop and throw up better and more frequently after the attack than do peregrines. On the other hand, they more easily become shirkers and many of them are poorer fliers after the moult, in which they differ from peregrines.

By means of the heron-train and other useful devices the noble eyas and noble brancher are given the same education. They fly in a cast with each other and with other falcons, without crabbing in the air or on the quarry. The eyas excels the noble brancher when undergoing instruction with the train, and completes her training more quickly; but if flown at a distant heron high on the wing she is rarely able to climb above the quarry and capture it. When put to this task the brancher, being a more accomplished flier, is able to circle above the heron and seize it, because she has had greater experience in flying wild. The eyas, in flying at a heron on the wing, keeps close to the earth until she is under it, then rises to seize it. If she fails, she rarely attempts to fly over it, like the brancher. The majority of noble branchers stoop and seize herons better than eyases of the same species. When the eyas stoops she cannot throw up again as well as does the brancher, nor does her stoop or other form of attack distress the heron to the same extent as the assault of the brancher. The noble eyas does not abandon her pursuit of the heron for another bird as often as the brancher does. Branchers of all species have greater fear of a dog running up to help them than have eyases of the same species. Eyases of every kind of falcon have less dread than branchers of men, dogs, and horses—indeed, of every animal that falcons generally fear.

Lanners much resemble noble falcons; and although there is a certain likeness between the branchers of the two species, their respective eyases are even closer in their similarity.

The branchers of the two species are alike in the way they react to training and in the manner they are flown at herons; but lanners are not so easily entered to the train and require longer instruction than noble falcons. They are not as strong, swift, and bold, nor do they withstand bad weather as well as gentle branchers. Lanners are more skillful in mounting above the heron, stooping, and rising again. They do not check so often at other birds; but they more easily become shirkers and cowards. The brancher of the lanner also inflicts greater injury on the heron by her various methods of attack; but she is more afraid of the assisting hound.

Eyases of the two species aforesaid are alike in the training they require, in their manner of flight at herons, and in the fact that they seldom check at other birds. They are both seriously affected by bad weather. The lanner eyas is, however, less strong, brave, and swift than the noble eyas and requires more lessons at the train than the latter. The lanner eyas, however, causes greater damage to the heron she pursues, striking harder and following the prey longer than the eyas of the noble falcon.

The careful observer will easily discover how the lanner eyas compares with the noble brancher and how the lanner brancher resembles, or differs from, the noble eyas. There exist the same likenesses and differences between the lanner eyas and the brancher, which is also the case with the noble eyas and brancher; and these comparisons hold good for eyases and branchers of other species of falcon—gerfalcons, sakers, and peregrines.

Our comparison of the nestling and the brancher of the saker is also competent in the case of the eyases and branchers of other falcons—gerfalcons, lanners, and peregrines. We have given special attention to the distinctions between eyases and branchers of the lanner and noble falcons, mainly because in our territories that lie in the sixth, fifth,

fourth, and third climatic zones these young falcons are more frequently found than eyases and branchers of other species. We have had ample opportunity to study both branchers and eyases of the gerfalcon and peregrine falcon, so that we have been able to observe them all and to verify the statement that eyases and branchers of these species bear the same relation to each other as do eyases and branchers of the two more common varieties.

Let us repeat that we have explained the resemblances to and the differences between saker falcons and all others in flying at herons. Other resemblances and contrasts may be pointed out in their manner of hawking herons, but the comparisons we have made seem adequate for our purposes.

We have discussed the hawking of cranes with gerfalcons and of herons with sakers. Let us now determine in what respects they resemble each other, as well as the nature of their differences: They are alike in that in both instances the train is used for purposes of instruction, also (in both cases) it is desirable that the falcon be slipped against the wind. A dog is used to rescue the falcon in

each form of hunting; and both herons and cranes are made to rise when necessary by either man or dog. After either the crane or the heron has been captured, the gerfalcon or saker is fed (in the same manner) on the quarry. The use of the train (as has been observed) varies somewhat for the two species of quarry. Cranes are generally hunted in the open fields and herons by the waterside. Although cranes and herons are made to rise by either men or dogs, it is evident, from what we have already stated, that it is not done in the same manner. The heron starts flying the minute it sees the falcon coming toward it, and often turns of its own accord toward her and drives her off with its beak. The crane, however, will not do this. The heron, in making its escape, turns and twists frequently, but not the crane. The heron at times rings up high as a means of defense. The crane, on the other hand, escapes by means of long straight flights. The heron's most frequent refuge is water, and in flight she sometimes strikes with her beak. The crane, however, uses its talons and feet to lash out in the air at the attacking falcon.

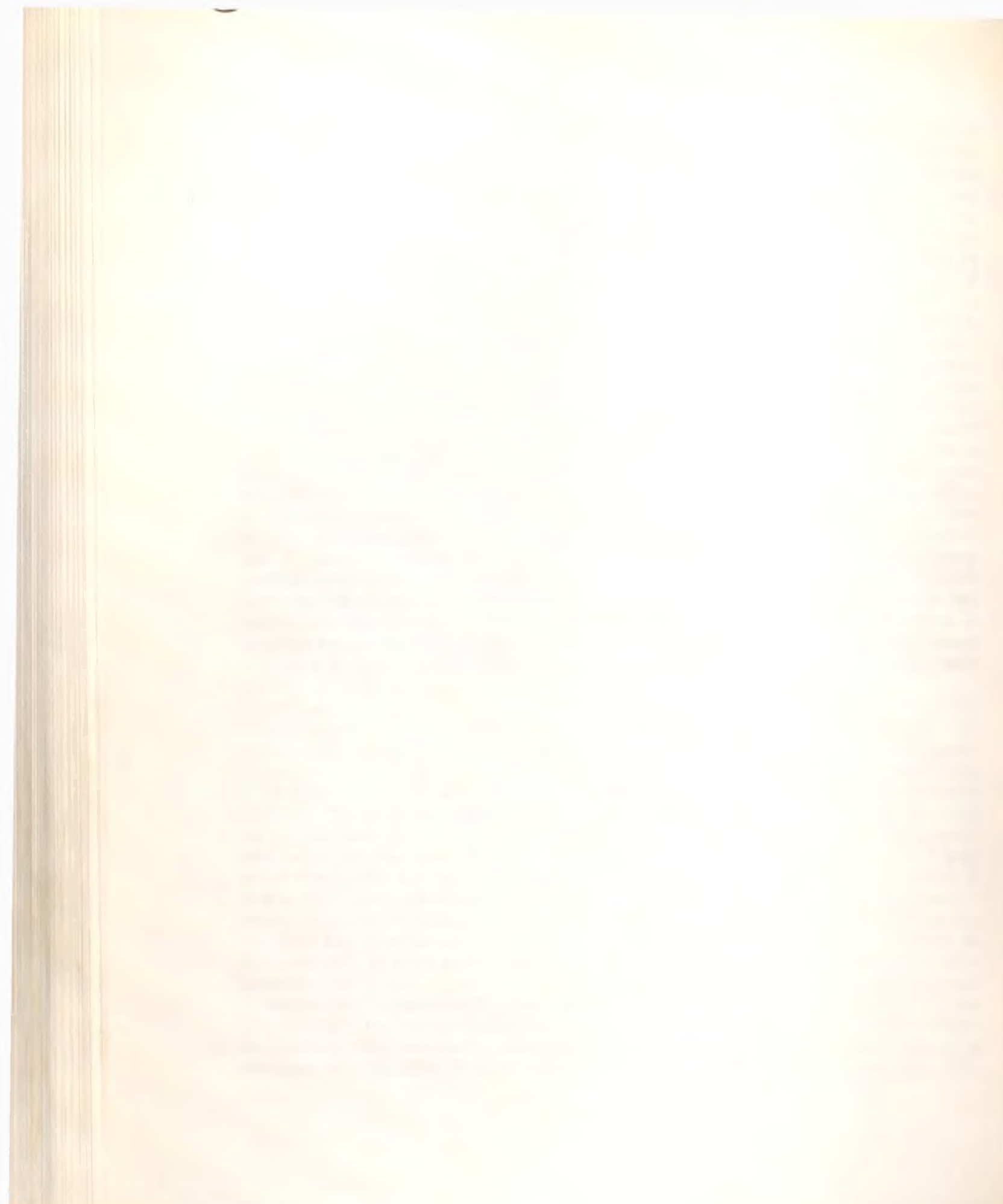

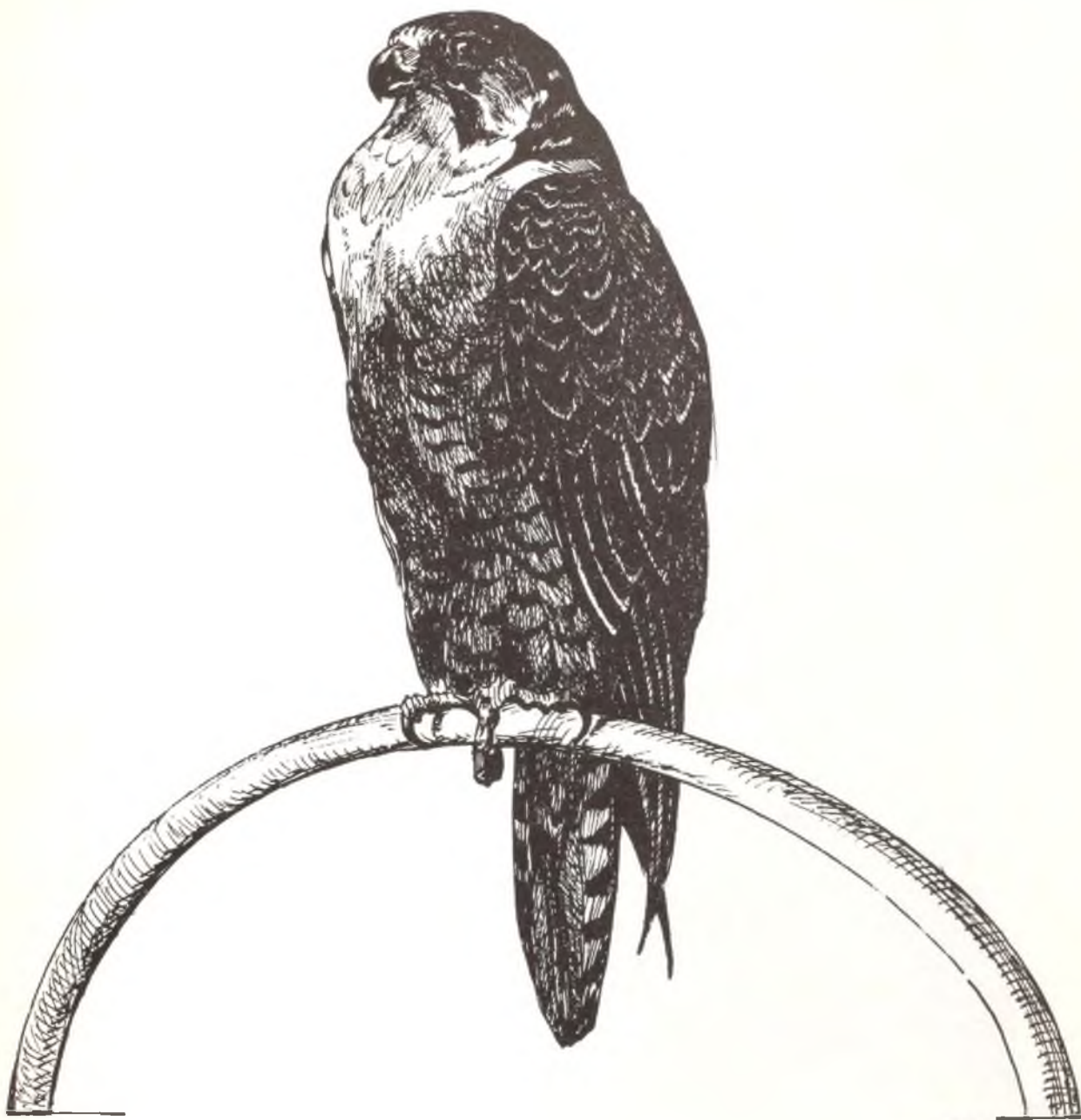

PLATE 121.—Mature female peregrine, northern race
(*Falco peregrinus*, var. *Calidus*).

360



E. Pfadtisch

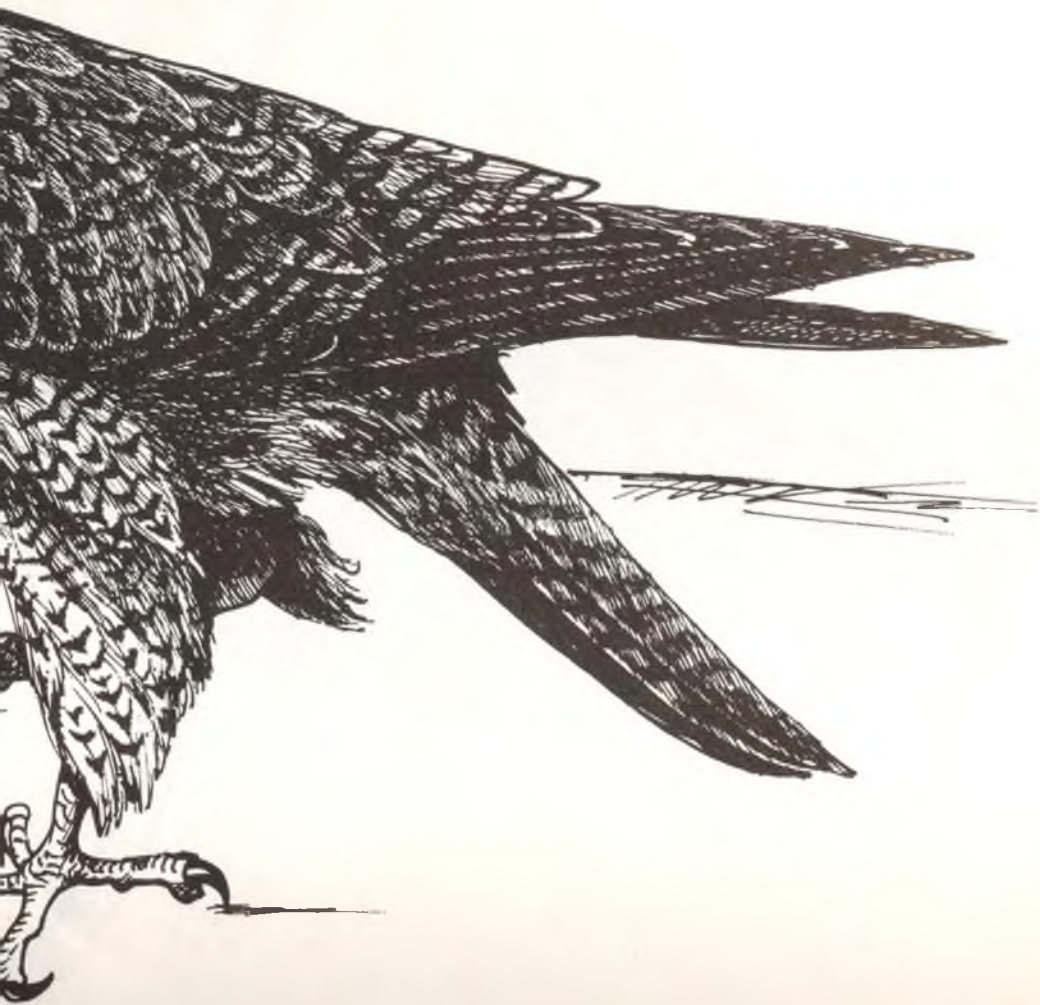

PLATE 122.—*Falco peregrinus*. (After Lodge.)

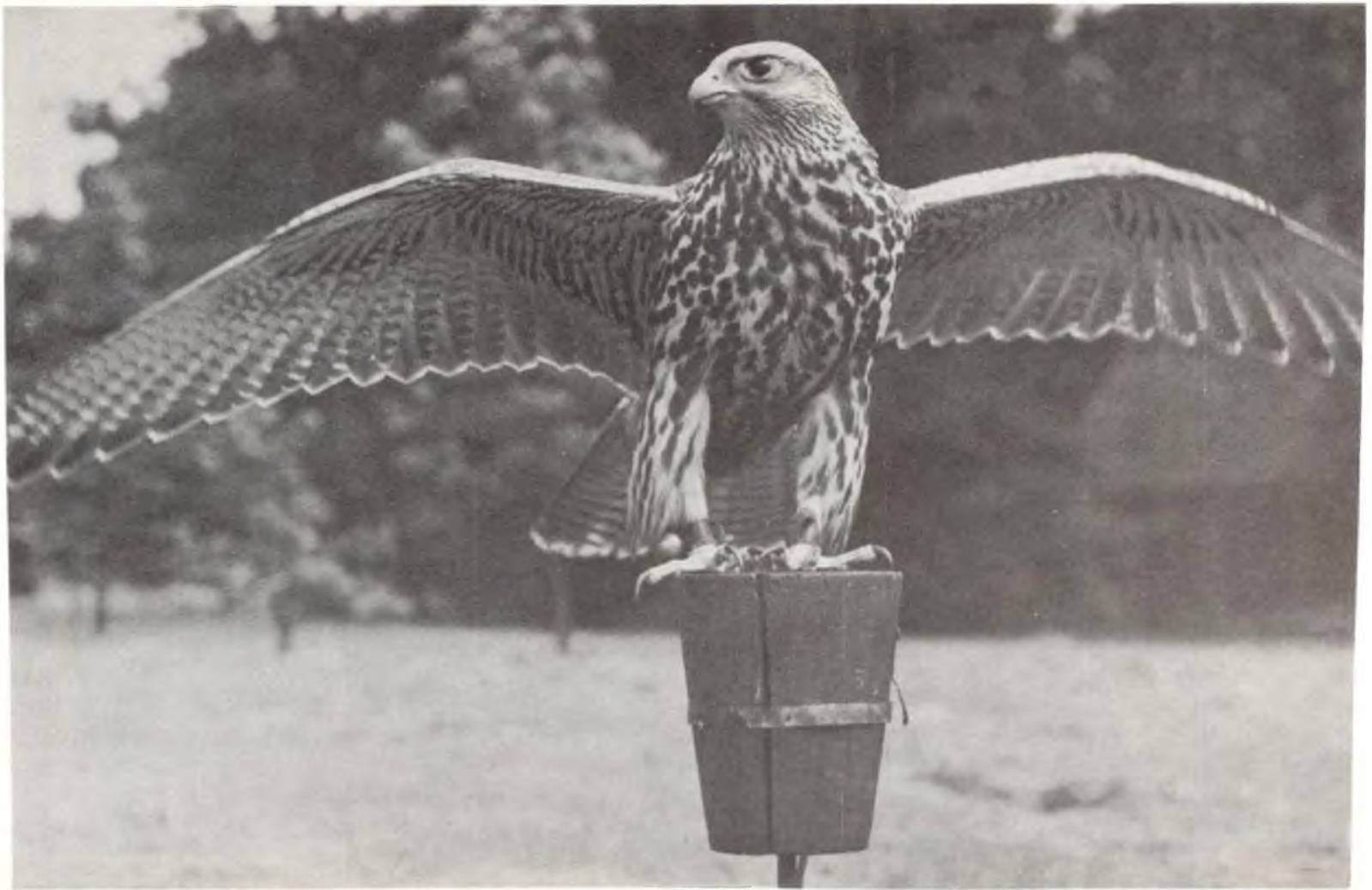

PLATE 123.—Iceland falcon. Courtesy of Dr. Walter Schlüter. (Photo by Fischer.)

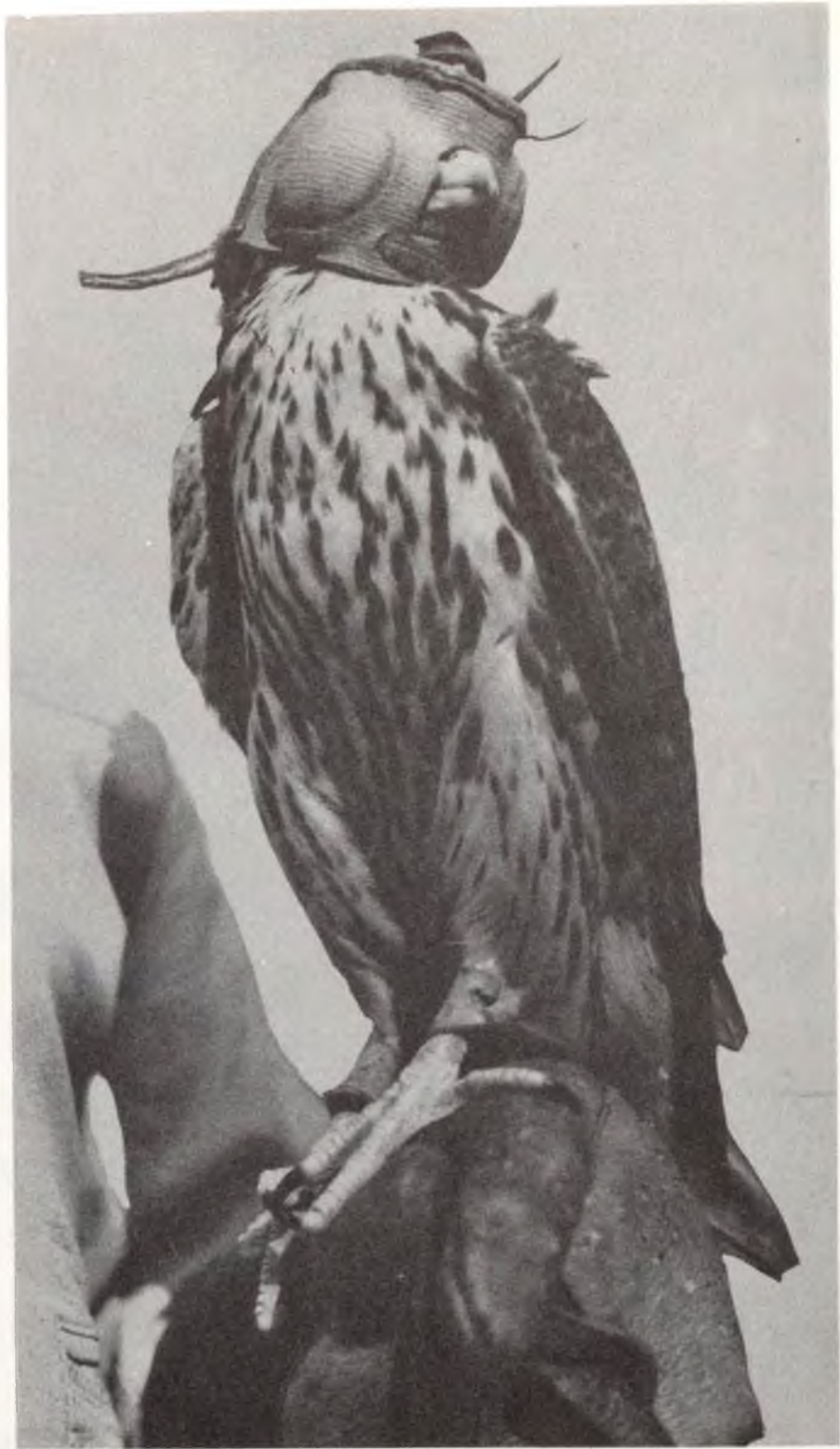

PLATE 124.—Female peregrine, "Diane," owned and trained by Dr. F. T. Barron and Mr. Homer Snow of Oakland, California.

BOOK VI

HAWKING AT THE BROOK WITH THE PEREGRINE FALCON

CHAPTER I

ON FLYING PEREGRINES AT WATER- FOWL, AND ON THE LURE MADE OF THE WINGS OF MALLARD DRAKES

THE HAWKING of cranes we have discussed in a previous section of our work, and have given our reasons for the assignment of this sport to the gerfalcon. The hunting of herons has been similarly allotted to the saker falcon, and for this choice we have also explained our motives. Now let us examine the problems involved in hunting shore birds, especially ducks and their kind, a task we apportion to peregrine falcons who are best fitted for it. The most common food of the latter is the aforementioned waterfowl.¹ These hunters therefore frequent streams more than any other species of falcon. Also their manner of flight is better adapted to taking such birds than to capturing any other avian species.

The peregrine needs a special lure for this form of hunting (just as the other falcons required theirs), and it must be made of the wings of the species intended to be used as quarry. Since it is our plan to teach peregrine falcons to fly at shore birds (these falcons are called *altanos*² because of the use to which they are put), the lure recommended for this purpose must be made of the wings of shore birds, especially of the mallard duck.³ We

prefer the male, or drake. For our purpose the wings of that species are the best, since they are heavier, more beautiful, and more durable than those of other ducks. Because the wings are much lighter than those of the crane or the heron, the lure must be made of more than two, even more than four, wings. If the lure were made of two or four, as were the two other lures, it would be so light that the falcon could easily "carry" it—a reprehensible practice, as pointed out in the chapter on luring. We must therefore make the lure of the wings of eleven mallards or other ducks, that is, from twenty-two wings. These wings must be cut from the body⁴ of the bird, arranged, and fastened together in the same manner as in the other lures we have described. An additional leather thong should be inserted and knotted tight in the upper joint of each wing, so that they may all be held firmly in place. The strap by which the lure is whirled should be at least three feet long, because ducks' wings are narrower and shorter than those used in other lures and, were the strap also short, it would be difficult for the falcon to see the lure.

¹ The scribe has written: *cibus namque suus sepius est de avibus de rapina predictus*. For *rapina* we substitute *rivera*.

² *Falcones altanos*. See Glossary.

³ Two forms of this word are given: *maslardus* and *massardus*.

⁴ *De corde = de corpore?* (Bologna MS., fol. 125^r, col. 2).

CHAPTER II

ON VARIOUS TYPES OF PEREGRINES
AND HOW TO SELECT THE BEST

Peregrine falcons exhibit a variety of types. Many of them have well-shaped limbs adorned with fine plumage, while the limbs of others, though shapely, have unattractive feathers. Some peregrines whose plumage is beautiful have ill-formed members; while a fourth class may possess both abnormally shaped bodies and defective plumage. These four classes are not equally commendable. Very few of those peregrines that are well-formed and have handsome plumage are undesirable unless they have been mishandled by man or have suffered some other misfortune. The well-favored are, in consequence, to be preferred, as a rule, to all others. Of the next two groups, i.e., those that have well-shaped limbs but poor plumage and those that are ill-formed—but have beautiful feathers, the former are to be chosen, inasmuch as a fine form gives them greater speed and activity, although they may not be as reliable¹ as the first class, that flaunt their fine feathers. However, beauty of plumage usually indicates an ability to retain what has been taught them; and, therefore, the falcons who possess this characteristic should be the best of the lot, whereas a faulty conformation of the limbs renders them incapable of executing their allotted tasks. Of two peregrines whose structure is the same, one should give preference to the more beautiful; for those that have poor plumage are usually found to hunt and fly well at jackdaws, crows, pigeons, starlings, and birds other than shore birds. This peculiarity arises from the fact that when the peregrine was wild she used these species as food and has thus been rendered useless for hawking at the brook.² Peregrines of hand-

¹ *constans*.

² The old technical term used to denote this form of falconry.

some appearance are usually the most steadfast and enduring, as well as the most useful at the water's edge, while those that are both ill-shapen and ugly rarely make good hunters.

Of that type of peregrine which we have designated as preferable the best are the largest; for a good-sized peregrine, if not competent for one purpose, can be assigned to a different task; its size compensates in some measure for minor defects in plumage and form. As a rule, strength goes along with bulk and carries also capacity for hard work in windy and stormy weather and ability to perform other labors that will be described in this chapter. An attractive form and handsome plumage are not, however, all-sufficient. These qualities should be accompanied by signs of good health and other evidences of superiority in a falcon, such as we have already described. If the hunter selected is not healthy, or has been badly handled, it is not likely to be worth while to spend one's efforts on her.

Since hawking at the brook is distinguished from other forms of falconry by certain special features, let us now discuss that diversion, just as we have described other kinds of hawking.

We have already shown how the gerfalcon is called to the lure. The peregrine is to be controlled in the same manner, the same call being used as in the former instance. This latter summons must take the form of a particular cry, and it should be used only for recalling the falcon. It must be distinct from all other exclamations one makes use of—as will be further explained. The plan for luring gerfalcons is also the best for peregrines.

The falcon that develops the highest pitch at the lure is the one to select for hawking at the brook. In this sport the falcon must soar high in the air, and any bird that has a naturally lofty pitch will also fly high to the lure. Such a falcon, indeed, gives decided promise of success as a hunter and for that

reason should be selected. The peregrine that moves her wings vigorously but not too rapidly nor very slowly (i.e., at an average rate) is to be placed in the class of preferred falcons, along with the high fliers. In teaching the peregrine to climb to a high pitch it is well for the falconer (who is calling her to the lure) to stand on a hill while the man who is to slip her remains in the valley or plain. Success in this feat is an indication that she will do well against wind and bad weather. Although those peregrines who move their wings infrequently are sometimes brave and make good heron falcons, nevertheless they are generally a bad choice for our present purpose, because they cannot fly well against the wind, as has already been said of all other birds that have a slow wing motion. The same is true of falcons who display an abnormally rapid wing beat or who fly with wings bent low under the body; for these are signs of weakness, and falcons who possess them are unable to contend with bad weather.

CHAPTER III

ON CALLING A PEREGRINE TO THE LURE; ON TEACHING HER TO LIKE IT, AND TO HEED HER MASTER'S VOICE

Peregrine falcons that are to be used in hawking at the brook must be exercised more frequently with the lure and called from a greater distance than other varieties. Although it has been shown that heron and crane falcons may be made shirkers through too great a love of the lure, yet there is little danger of this error at the beginning of the peregrine's training.

In order that falcons who are being taught to fly at the brook may be strong enough to perform the tasks required of them, they must not be kept as thin and hungry as birds employed in other forms of hawking. Therefore, as will

be revealed in what we are about to relate in this book, they must be trained with the lure for a longer period and rewarded more frequently while on this decoy, so that they will develop a greater liking for it. If this is not done, they may refuse to return to the lure when called and may take to hunting weak birds that cannot defend themselves. This last habit they have acquired in their wild state, and it is more enjoyable to them than coming down to the lure. In consequence, they must be thoroughly trained lest, through this preference for their former quarry and lack of pleasure in the lure, they wander off and are lost. There are, in fact, very few falcons, no matter how well trained in hawking at the brook, who do not eventually lose interest in the lure (because of their preference for live avian quarry) unless great care is continually taken to follow our instructions for teaching them. Moreover, peregrines fly high and can see birds at a distance; and when, attracted by the kind of quarry they were earlier in the habit of seizing, and because of other fortuitous circumstances, they come to earth away from the falconer, they are easily and quickly lost to sight, especially when they fly in the wind.

It is necessary for falcons trained to hawk at the brook to ring up and wait on above the falconer, in order to capture those birds sent up for her. The more directly the peregrine soars above the falconer who is putting up the quarry, the more easily she descends upon the prey, irrespective of the direction in which it is served. It is chiefly through her love of the lure itself that a peregrine is taught to wait on right over the falconer; and the greater her liking for that decoy, the more prompt will be her response to her master's call.

The foregoing discussion reveals the necessity for the development in the falcon both of a fondness for the lure and of a quick response to the falconer's voice. There are many falcons who, in the beginning, speedily learn to

like the lure and to be keen for it; but, as stated, this is not enough. It is necessary also for the falconer to reward them constantly on the lure, so that it becomes an established habit with them to indulge in it. If this is not done, some of the obstacles we have already mentioned may cause them to forget the pleasure they have derived from it, because it has not yet become a habit with them.

CHAPTER IV

ON THE DANGERS OF A HURRIED EDUCATION WITH THE LURE; AND ON THE PREMATURE EMPLOYMENT OF A PEREGRINE IN HAWKING

There are, indeed, falconers who are in a hurry to use their falcons in hawking before they have been properly made to the lure. They are in haste because they look forward merely to the pleasures of the sport, because they are afraid the season for flying their falcons will pass, or because they are envious of another falconer whose birds are already trained and they wish to educate their own falcons as quickly as or even more rapidly than he. Another reason that a falcon grows to dislike the lure is that for many days she may have been capturing birds and has fed upon them but has not in the meantime been called down to and fed on the lure; or else she has been lured but has received no present of meat, and this neglect has occurred so often that she feels she has been deceived. Again, the falcon may be suffering from a maladjustment of her hood. For all these reasons she comes reluctantly to the lure and she prefers birds that are her usual prey. This state of things is deeply to be deplored if for no other reason than that there is no alternative means for a man to keep or to recover a falcon he is flying nor one so well adapted to his purposes as the lure. The man who hunts with a falcon that dislikes the lure (although she may

be tame enough) runs the risk of being unable to recover a strayed or temporarily lost hunter.

The falcon that dislikes the lure may show it in various ways. Some birds will not approach it under any circumstances. These are of two classes: Those who wait on over the falconer expecting him to toss out a live bird (such falcons have at some time or other become used to this practice) or to flush a bird for them to take. When a falcon of this sort sees that no bird is given her, or is put up after she has waited on for some time, she will either descend and settle near the falconer or go off on her own account to hunt other birds or to perch somewhere far from him. Another class is that of falcons who are called back to the lure with more or less difficulty, whose loss may be the result of some accidental occurrence—an unlikely event when a falcon likes the lure.

CHAPTER V

ON REASONS WHY THE FALCON MAY NOT BE ATTRACTED BY THE LURE

Some of the reasons why a falcon does not come readily to the lure are connected with the bird herself, while others are extraneous to the falcon. Among those causes that derive directly from the falcon herself we point to the following: She may be a little overconditioned, or be exhausted by her flight; she may be timid or may wish to bathe; she may have been improperly fed and may not be hungry; or else she may be affected by some disease.

Outside influences that intervene to prevent the falcon coming to the lure may be bad weather, an unfavorable terrain, or the presence of other birds. Variations in weather may be seasonal or diurnal. For example, in either autumn or spring changes in the temperature of the air may range from hot to cold, since these seasons lie between summer and winter; and as the weather changes, the disposition of

the falcon varies. Since she is more hungry in cold weather, she comes more readily to the lure at that season; and the reverse is true of hot weather. During the equable (warm) days of spring and autumn, falcons, as a rule, soar high, spread their wings and tail, and circle about, to cool themselves. A considerable difference is to be observed in the autumn between the behavior of saurus (unmoulted) falcons, who are undergoing instruction, and those that have just appeared on the scene but that have (previously) been trained. The latter have acquired such an amount of fat (which has grown firm while they were confined in the moulting house during their long period of rest) that it is difficult to reduce their weight. The result is that they become overheated and scorn food, seeking to cool themselves rather than to come to the lure. Moreover, as it is some time since they were lured (while in the mews), they have forgotten their customary liking for the lure and are therefore less eager to come down when summoned. Any bad habits they may have acquired while being made to the lure (before they were placed in the mews) may be perpetuated, and their reluctance to come when called will now be increased. Furthermore, moulted falcons are often those that have already taken live birds and are thus able to distinguish them from a decoy. The result is that if they chance to see a bird they are accustomed to capture, they will desert the lure and fly off in pursuit of it. Even if they do not see such prey they may not approach the lure because they cherish the hope that some sort of quarry will be put up for them.

The excess flesh of saurus falcons is less solid and more quickly removed by dieting than that of the intermewed bird. As we have explained, reduction in weight is a requisite procedure when falcons are undergoing instruction. Since saurus falcons are regularly summoned to the lure and have previously developed no bad habits, they come down

more readily when called. Moreover, young, unmoulted falcons have taken so few birds during their association with man that they are unable to distinguish them from the lure and have not on that account developed the depraved practice of not responding to the appeal of a decoy. From the foregoing explanation it is clear that in the autumn saurus falcons are more easily lured than older, intermewed birds.

In spring, however, it is a common trait of both moulted and unmoulted falcons to respond less willingly to the lure than at any other season. At this time of year they grow fat on a small amount of food, and this increase in condition makes them disdainful of the lure. Furthermore, the approach of the mating season renders them more active (*alacriores*) and less ready to come when called. Again, they enjoy the fine weather that accompanies spring and soar more freely.¹ One should not forget, also, that they retain any bad habits acquired in winter from the use of the lure, and this observation is in part proved by a reluctance to respond to the call of the lure during the following springtime.

Summer days being uniformly warm, falcons do not show the same diversity in their response to the lure that is observed in spring and autumn; usually they come when called. Also, the aestival mating season is passing and no longer interferes to any extent with their response to the attractions of the lure. Moreover, even if they have already captured many birds in winter (enjoyable as sport and food) and can distinguish them from decoys, they are beginning to moult and, in consequence, feel heavy and sluggish. They do not, at that time, wander far from the falconer, and find little enjoyment in flying at birds because they are not confident of being able to make a capture. Also, hawking is then hard work and often results in failure because of the falcon's defective plumage.

¹ *saurant libentius* (Bologna MS., fol. 127, col. 2).

If she is a young falcon in her first year, she has been continually in routine training with the lure but has captured so few birds that she has not yet learned to prefer them to the lure. As a rule, novice falcons come more readily to the lure, since they are still being trained with it, than they do after they have taken many birds. For these reasons young falcons (as well as others) seek the lure more readily in summer than in spring or autumn.

Winter days are, as a rule, colder than those of spring or autumn; and falcons, like the weather, are not so changeable in their disposition as in the two last seasons. In winter the mating period has not begun and falcons are hungrier. Also, because of the cold and bad weather, they grow sluggish in hunting but are more willing to come down to the lure than in spring or autumn.

Concerning the kind of day on which a falcon comes best to the lure, it may be said that on clear days falcons are in good spirits and are inclined to hunt their quarry with added zest; also the quarry is more in evidence, flying from place to place. The consequence is that a falcon who has not been specially and thoroughly made to the lure is not easily induced to come to it in such weather, because of her preference for avian prey, and because she is able to see them at a distance. The same is also true of cloudy days.

The best periods of the day for luring the falcon are the hours just before the third² and the evening hours; at that time the falcon comes to the call more readily than during the middle of the day. Also, at midday eagles and other predatory birds that the falcon fears are abroad; and at noon the falcon has little appetite for food, to draw her down to the lure. She also likes to circle about and cool off overhead in the middle of the day—an added reason why she comes less willingly to the lure.

² That is, before 9:00 A.M.

The late afternoon is preferable to the early morning for calling a falcon to the lure, for she is usually fed in the morning and, even though she be given but little food on that occasion, she is more hungry at sunset and for that reason readily comes when called. The later the hour the more eagerly does a falcon respond to the lure, for then she sees fewer birds for which to desert the decoy and her appetite for the latter is consequently keener.

The character of a locality may prevent a falcon from coming when lured. Any area in which falcons are not accustomed to hawk is undesirable. For example, if a falcon is used to hunting in places that are level and free of hazards, she will not respond readily when lured in rough mountainous country or in wet areas or in places where there is dew on the grass. Nor does the falcon like localities that appear to her to be covered with deep water, for example, meadows with thick grass that holds the dew. Snow lying upon the ground is an additional obstacle (that prevents a falcon from coming eagerly to the lure), for she dislikes and fears snow. Equally dreaded are grassy places where the herbage is both long and thick, such as fields of tall wheat or areas covered with shrubs; for all such places falcons have an antipathy. They also disapprove of valleys, since they enjoy towering aloft where a wide, unobstructed view is obtainable. They usually shun valleys, but they come eagerly to the lure on high ground. They are unaccustomed to hawking over rocky and dry river beds³ and, when possible, avoid them. We speak in this way of the foregoing areas not because falcons alone refuse to come to the lure in them; indeed, all birds of prey fear them and, when summoned to such localities, come with reluctance. But if one lures falcons frequently in such places they eventu-

³ *in locis petrosis fluvialibus*—a description of the typical southern Italian and Sicilian river bed over a large part of the year.

ally grow accustomed to and no longer shun them.

Such are the obstacles to luring that arise from particular localities. To repeat, these as well as other sites are mentioned not because in them all falcons refuse absolutely to come to the lure but because some birds either do not respond or respond unwillingly. In each case two factors must be taken into account—the degree of the falcon's normal desire for the lure, and her fear of the area involved. Other reasons for a falcon's hesitation in coming to the lure will be treated later in our chapter on hawking with peregrines.⁴

CHAPTER VI

ON TRAINING THE PEREGRINE TO WAIT ON; AND ON THE WEATHER AND HOURS PREFERRED FOR THAT EXERCISE

When a peregrine falcon has been trained with the lure in the manner and to the degree we have described, she must also receive instruction in another activity peculiar to this form of hawking. These lessons should include her education with the lure and precede any attempt to hunt at the brook. This new activity, involving the use of the lure, is closely related to actual hawking. The falcon must be taught to circle about over the head of the falconer, that is, to wait on.⁵ Inasmuch as the lure is used when instructing the falcon in this fresh maneuver, waiting on is associated with luring; but because live birds are released for the falcon while she is circling about, it partakes also of the nature of sport. Thus instruction in waiting on is an intermediate stage between luring and active hawking, not only in the order in which it is taken up but in its very essence. We call this

act "waiting on" because the falcon flies about in circles above the falconer waiting for quarry to be put up.

One should choose suitable weather, as well as a proper hour of the day, for giving this instruction, and select also a locality well adapted to the new task. Finally, one must pay careful attention to the method of instruction.

A falcon should never be expected to wait on in the rain; for then her feathers become wet and, although she may display a desire to accomplish what is required of her, she is unable to comply because of the condition of her plumage. Nor must one choose a day when a strong wind is blowing, because, although the falcon may wish to keep directly above the falconer as she circles overhead, a stiff breeze will carry her away from her position. The novice, unaccustomed to this fresh activity, does not know how (and may even lack the desire) to make the necessary effort to wait on against the wind.

Misty weather is also inappropriate; for when the fog is thick the falconer cannot see his bird nor she him, and if, while she is waiting on in such weather, she spies a bird and pursues it, the falconer cannot determine in which direction to follow her and she may be lost. A further objection is that in such weather falcons become indolent.

Clear weather, without wind, is excellent for teaching a falcon to wait on, for then she feels lively and eager to fly. On such a day—in summer—an early hour is preferable, because the heat of the day increases rapidly and predatory birds, which the falcon fears, are not in the air until later, when most species are aloft. Finally, overcast days are really the best, and this is true in both winter and summer.

Snowstorms frighten the falcon and wet her feathers (making her sluggish), so she must not be made to wait on when snow is falling.

⁴ Book VI, chapter xx, p. 389.

⁵ "To wait on" is the English technical term. The equivalent barbaric Latin is *circumvolare*.

As to the best hour of the day there is a difference of opinion. Some men say that at the beginning of the falcon's education in waiting on, the best time is before the third hour. For this choice they give the following reasons: At that time, if a circling falcon sees a bird and checks at it (or deserts the falconer for any other purpose), there remains the whole day to search for her and, whether or not she has captured a bird, she is more easily recovered before night closes in. Stated in another form, these same falconers maintain that if a falcon is sent up, to wait on, in the evening and flies off for some one of the reasons mentioned, night will probably fall before she is found, since there is little time left in which to search for her. Moreover, if she has caught a bird and fed upon it, her recovery on the following morning will be all the more difficult; for she has remained alone all night away from the companionship of men just as she was accustomed to do in her wild state. This experience makes her forget to a great extent the domestication she has undergone; and as time passes she becomes wilder and can rarely, if ever, be recovered. Even though she has not fed upon her quarry, she has nevertheless grown less tame than she would be if lost in the daytime. This is because of the darkness and solitude in which she has passed the night.

There are other falconers, however, who declare that the evening hours are the best in which to send up a novice to wait on because at that time (in summer) there are no wild falcons aloft cooling off, since with the coming of night the air grows colder, whereas in the morning the heat is increasing. These experts also point out that the birds the falcon fears do not make their appearance in the evening, nor are there at that hour so many birds flying over the countryside for the falcon to pursue and then go astray.

We, however, are of the opinion that the morning hours are best, since at that time

falcons are more active and other conditions are favorable for training purposes. Also, the hunting bird is not hungry and so takes pleasure in flying. Toward evening she is eager for food and flies at a low pitch, making it difficult to judge the quality of her performances. She may have the good intention of flying high; but hunger prevents it, and the hour interferes. Again, in the evening all birds prefer to rest rather than to be aloft. We, ourselves, forbid any waiting on after midday at any season of the year except for a short period in winter.

When asked how often during the day a falcon ought to be sent up to wait on, our reply is, once only and at the hour specified. If anyone wishes to hasten the training of a falcon, she may be made to wait on twice a day in summer—once in the morning and again in the evening—but this rule applies to cold climates only, inasmuch as in Hyperborean countries the day is longer and the heat less intense.

CHAPTER VII

ON THE BEST ENVIRONMENT FOR WAITING ON; AND ON THE OBSTACLES TO BE AVOIDED

We have spoken of the weather and hours of the day that should be chosen for teaching a falcon to wait on, and have also indicated conditions that are to be avoided. In our discussion we have touched also upon the various opinions that prevail in this connection, pointing out those we consider best-founded. Now let us discuss the proper environment to be chosen for this operation and the obstacles to be removed or avoided. First of all we must mention that a prerequisite for this activity is that the falcon be kept in a bodily state midway between leanness and fatness, and that this regulation may be modified by her eagerness to fly. If such a proviso is not kept in

mind the bird may not perform her task as she should.

When the falconer has given all the foregoing conditions due consideration, he should ride out, carrying the falcon, the lure, the meat, and other necessities. Avoiding localities that present the hazards we have already mentioned, including those that render the falcon reluctant to come to the lure, he must ride some distance off the highway and away from places frequented by pedestrians, horsemen and, especially, dogs. These canines come running at the sound of the falconer's voice. Dogs are also inclined to run after anything thrown by a man; hence when the falconer tosses the lure, to recover the falcon, any hound present will run toward it.

If a dog reaches the lure first, the falcon, fearing the animal, will not come down; if the falcon arrives first, dread of the dog running about will force her to abandon the lure. Indeed, such a fright may make it impossible ever to recover the falcon.

When someone is passing by, do not release the falcon (intended to mount and wait on) until the stranger is out of the falcon's sight, because, if she sees the outsider she may go to him, thinking he has called her to the lure. Care must also be taken that there are no birds at hand that a falcon is likely to chase; nor avian enemies aloft that she fears and that might disturb her. If horsemen are riding with the falconer, he should keep them close about him. If one of them should dismount, or has already dismounted, the falcon must not be sent up until he has remounted his horse, lest, seeing him, she might think she is to be fed by the man on foot and fly to him.

The country in which a novice is sent up to wait on must be sufficiently open to permit the falconer (should his bird fly off) to follow easily and without encountering obstructions. Also the lay of the land should allow the falcon to see the lure when it is thrown out.

If it is a windless day when the falcon is to be slipped, the falconer should go a little distance from his companions, in whatever direction he chooses, and far enough for the falcon to distinguish him clearly from the other men.¹ If there is wind blowing he should move against it, leaving his associates down wind. When the falcon is hooded, the falconer must remove the head covering, and allow the bird to mute and rouse if she wishes. It is best that she be permitted to do this while on the fist; for, if not, she will do it during flight and this belated act may prevent her from attaining a high pitch. When one removes her hood and then waits until she mutes and rouses, the next time this is done it will be a signal to the falcon that she is to be tossed from the hand. Nevertheless, removal of the hood is not always sufficient indication to a falcon that she is to be slipped. Sometimes when she is unhooded she is feeling sluggish and makes no effort to fly—a condition attributable to her condition, to the weather, or to the fact that she has grown accustomed to being carried for long periods without the hood. Therefore, when the hood is taken off, she does not realize she may be tossed from the hand but thinks she is about to be carried in the manner that is most familiar to her. For this reason whenever either a hooded or an unhooded falcon is to be slipped from the hand, it is well to treat her as we shall direct so that she will realize she is to be flown. After the hood is removed the falcon will, or will not, open her wings and show that she is ready to fly. If not, the falconer must move forward with her against the wind, a movement that should stimulate her to fly. When he has done this the carrier must extend his arm, neither too high nor too low, but at the level usual for carrying the bird; then he must move his fist forward, gently at first, then with increasing force. He must not re-

¹ *magis tam expeditam secundam distantiam qua falco possit discernere ipsum ab illis.*

lease the jesses until his hand has completed the forward movement, when he should open his fingers and let the falcon go. If she shows from the outset that she is anxious to fly, she should at once be released. We have already detailed the indications of her desire to fly.

If the falcon is unhooded, the falconer must extend his arm in the same fashion and carry on in the same manner as when dealing with a hunter with no headgear. Then on a second occasion the falcon will know that she is to be tossed from the fist.

CHAPTER VIII

ON EIGHT MODES OF BEHAVIOR OF FALCONS SENT UP TO WAIT ON

As not all falcons have the same manner of circling about when sent up to wait on, let us now describe their various modes of behavior after they have been tossed from the fist for that purpose.¹ In this respect falcons may be divided into two categories: those that remain near the falconer, and those that fly off.

Among those that keep close to the falconer, some circle high above him and do not descend to perch, others remain in the air but fly at a lower level; a certain number complete two or three gyrations and then, without further delay, come down and settle in the vicinity of the falconer. A fourth class goes at once to perch near by, making no attempt to wait on.

¹ *Set quia omnes falcones non habent unum modum circumvolandi quando jactati sunt ad circumvolandum oportet nos dicere diversitatem quam habent falcones postquam jactati sunt ad circumvolandum in circumvolando* (Bologna MS., fol. 139, col. 2). The reader of this translation should remember that the frequent repetition of the word *circumvolandum* (flying or circling about) in the same sentence does not constitute in barbaric Latin the literary offense it would represent when found in ordinary English. Throughout the six books this peculiar Latinity is often encountered; but we have, of course, avoided its literal construction as much as possible.

Of those that fly away from the falconer, some circle high in the air, moving continually farther off, and do not come to earth. A second class fly at a lower level without settling but steadily retiring from the falconer. Others make two or three circles and fly off, to perch at a distance. The birds of the last group make no effort to circle about, but immediately fly from the falconer and come to rest far from him.

In training a falcon to wait on, as in other activities of falconry, all those modes of behavior where the falcon remains near the falconer, whether or not she circles about, or whatever she does, are preferable to any that involve her flying away to a distant spot.

Of the four classes of falcons that stay near their master, the first is the best; for a falcon of this class is already beginning to perform those acts that the falconer is trying to teach her, and she will more easily than the others be brought to perfection in their execution. The chief educational aim is to induce the falcon to fly high, almost perpendicularly above the falconer; for in this position, no matter in what direction the quarry is put up below her, the falcon will be at a favorable distance from the prey and be ready to stoop so as to strike or seize the quarry.

The second manner of flight is less desirable, because of the falcon's failure to attain the proper pitch; indeed, the lower the pitch at which a falcon starts to wait on, by just so much does her mode of flight fall short of the effectiveness achieved by birds belonging to the first class.

Falcons of the third class display three shortcomings in their flight when compared with those of the first category: Their pitch is lower; their waiting on lasts only a short time; and, finally, they go to perch on the ground.

Falcons of the fourth group are the worst of the lot, because they exhibit none of the good qualities of the first category and their

actions are entirely contrary to our plan of instruction. They make no effort to fly properly but settle at once close to the falconer.

Of those falcons that leave the vicinity of the falconer, the least reprehensible are those of the first group. Inasmuch as they wait on at a high pitch, they accomplish at least a part of the falconer's purpose, although their flying off is objectionable. The second class is guilty of two faults: they wait on at a low level, and they desert the falconer. The third group are even more incompetent because they fly low for a short time only and then settle down at a distance from their master. But the fourth² group, under this division, is the worst of all, for it shows none of the good qualities of a well-trained hunter. To repeat: The falcons of the fourth category do not wait on at all but at once fly away and come to rest a long distance from the falconer; hence it is extremely difficult to bring them to any degree of perfection in the art of waiting on.

The falcon that does not stay near the falconer may play other tricks, such as raking away after some bird she sees immediately upon being released from the fist and without circling at all overhead; or, in case she does not see any quarry, she flies off in search of one. This last fault we do not find very reprehensible except in that she does not wait on. Her pursuit of, or search for, a bird is to be attributed to a courageous spirit rather than to ill will; but, should it develop into a habit, the results will be bad.

CHAPTER IX

ON THE EDUCATION IN WAITING ON REQUIRED FOR A SUPERIOR PEREGRINE

Let us discuss again these modes of behavior (one by one) found in the best ex-

amples of the hunting peregrine, and in the order given. As the first manner of flight portrayed in the preceding chapter is the best of all, we shall describe it fully and compare all others with it. First, we shall canvass all the steps followed in training a falcon of the first class to wait on, and then furnish such additional instruction as is needed to make falcons of the remaining categories conform to the standards of the first group.

Should the falconer, when the falcon has been slipped in the manner described and is waiting on above him, perceive that for some reason or other she desires to fly off and has moved some distance away, he must call to her, whirl his gauntlet in his right hand high over his head and move from where he is standing in the direction the errant falcon has taken. The falconer must also call out, so that the falcon will not fly far from him; and the cry used must be one different from that employed in luring. Were it the same, the falcon would then lower her pitch, hoping the falconer would throw her the lure; for she remembers the call used when she was being lured. There are further reasons why the call must not be the same in both instances, and these will be discussed later on.

The gauntlet is whirled in the right hand above the falconer's head to teach the falcon to distinguish between the falconer¹ to whom she is to go and other men who may be present. As this motion resembles that of the lure, the falcon will turn back toward the falconer; but when she sees it is not the decoy, she may not descend the whole distance. The falconer moves from his first position toward the falcon in order that the latter may be able to distinguish him from the others, in case she does not recognize his call or the whirling of the glove to which she is not accustomed. The falconer, therefore, must continue to approach the falcon the while he calls aloud and swings

² The Latin text says, *Quintus modus*, an obvious error.

¹ The Mazarine text, p. 541, supplies *ad*, which is missing in the Bologna manuscript, fol. 130, col. 1.

his glove. When he has reached a point beneath her, he should repeat the same cries, toss out the lure, and finally take her up. The falconer does this so that when, on another occasion, the falcon sees him moving toward her and performing the other acts we have indicated, she will come back toward him and will learn to follow him because she remembers the lure that was thrown to her on the earlier occasion.

So far the falconer does not know what will be his falcon's manner of waiting on, and he must, in consequence, watch her carefully. If her performance assigns her to the first category,² in which case she is more valuable than other birds, she will, even while she is waiting on, furnish all the signs (previously detailed) of an excellent hunting falcon. She spreads her tail, flies with a strong wing beat, and climbs steeply in circles of short circumference, increasing her pitch at each gyration. By her manner of mounting one can judge the strength of the falcon and the soundness of her loins. A bird otherwise strong but with weak lumbar regions makes circles of too large a circumference.

As the falcon waits on, the falconer should ride from point to point in order to teach her to follow him and to circle directly above him wherever he goes. He must take care, however, not to ride so fast as to tire the falcon in her efforts to follow him; and if there is a wind he must not ride against it, for it will exhaust her to follow him up wind.

After the novice has been sent up to wait on, the falconer must call her to the lure after a short time but not until she has described two or three circles in the air. Were he to summon her to the decoy earlier, the time would be insufficient for her proper education, and especially to accustom her to waiting on. On the other hand, he must not delay too long in luring her after she has completed

² That of those who do not fly away from the falconer.

two or three aerial circles but should call her down at once thereafter. Were he to postpone for a longer period a call to the lure, the falcon might leave him and rake away, because she is a novice that does not understand what she is expected to do or why; or she may so act because she is weary of waiting on; or, during her long period of soaring, she has spied either a bird that she turns to follow or others that she fears will seize her,³ or because she has encountered still others that mob her, such as crows and ravens. For all these reasons (we repeat) one should not delay too long in luring a novice that is waiting on; but when the falcon in her evolutions turns toward the falconer and flies close above his head, he should take the lure from his side and give the decoy-call (to attract her attention) to make her look down at him and see clearly when the lure is thrown out. Should it happen that the falcon has meantime flown away from the falconer, she will thus be induced to return at the sound of this peculiar cry in the hope of having the lure tossed to her. In case the falcon circling in the air does not remain directly above the falconer, he should ride until he is beneath her and then immediately give the call and toss out the lure. This bait must not, however, be thrown out in any of the places previously mentioned as displeasing to the falcon. The hurling of the lure while the falconer is directly below the falcon serves to accustom her to remain of her own accord straight above him. This she would not learn to do if the falconer were to cast the lure to her while he was some distance away. The lure must be thrown in the following manner: It should be not swung in circles, nor thrown upward, but tossed parallel with the ground and far out from the falconer.

When the falconer has thrown the lure in this fashion he must immediately move a short distance from it. This is done because

³ Eagles or vultures.



PLATE 125.—Initial letter of the Incipit of Book VI, *De Arte Venandi cum Avibus*, Bologna Codex. MS. Lat. 419 (717)



PLATE 126.—“The Return Home.” Hawking in the fourteenth century. The noble lady falconer, her attendant, dogs, cadger, and extra (transported) hooded falcons.



PLATE 127.—Duck-hawking in the seventeenth century. Print by Howitt, 1799.



PLATE 128.—“A Heron Hunt in 1750.” From a painting in the collection of the Landgraf of Hessen-Cassel.

the falcon who has been sent up to wait on (a feat that is new and strange⁴ to her), no matter where it is done and no matter whether she is tossed from the hand or leaves it voluntarily, feels herself freer than usual and may for that reason grow somewhat wilder. She may therefore hesitate to settle on the lure because of the proximity of the falconer and his horse.

When the falconer sees that his bird has descended and is resting upon the lure, he should not approach her until he observes⁵ that she has begun to feed on the meat of the lure. Even then he must not go directly toward her but must ride in a circle and from then on follow the directions given in the book on luring falcons.⁶ In its pages he will find set forth complete instructions on how and when to feed the falcon in training. This should be done once a day, at the hour we have specified, and for three or four days at the most—ample period in which to teach a falcon how to wait on.

Whenever a falcon, because of the wildness that occasionally comes over her while waiting on or because of some aspect of her surroundings that frightens her or for any other reason, does not settle upon the lure but merely stoops over it, the falconer must not hurry to pick up the decoy but should allow her to stoop as often as she will. It must be remembered that falcons often stoop a number of times at the lure when they are afraid of some source of unrest in the locality. They will then circle above it and, finally, gaining confidence, may settle either upon the lure or near by. When the falconer sees the falcon thus perched upon the lure he should go in and follow previous instructions. If, how-

ever, she merely lands near by, he must postpone his approach until she has reached the lure and is standing on it. If the falconer perceives that his bird is about to behave in the manner described above, he should call to her (using a different sound from the one he employs either in luring or while his bird is waiting on) to inculcate in the falcon (who is making off) the habit of coming back to her position above him. Then, as soon as the falcon has resumed her proper position directly over the falconer, the lure must be thrown out and the lure-call given.

On the second day of training, the falcon must be allowed to wait on a little longer before she is called down. On the third and fourth days the time may be extended. By these stages the falcon will learn to mount high in circles and remain for a long time waiting on, always directly above the falconer, and to follow him wherever he goes.

CHAPTER X

HOW TO CORRECT THE FLIGHT OF FALCONS WHO FLY LOW IN WAITING ON

The second class of falcons¹ is inferior in hunting value to the first in one respect only: they fly low. When they do this the falconer must determine whether it is because of their liking for the lure, because they are hungry, because their excessive leanness renders them too weak to fly at a high pitch, or because the hunger that accompanies this emaciation makes them anxious to be fed and causes them to keep close to the falconer. If the falconer decides that it is none of these conditions that causes the falcon to fly low, he may be sure that it is her normal mode of flight.

One can judge whether her pitch is low because of the lure or because of hunger by the following signs: In the first case, a falcon

¹ Of those who remain with the falconer.

⁴ The Bologna text (fol. 130^v, col. 1) reads *q'viptus est novus sibi*; the Valencia MS. (fol. 214) gives us, however, *quod ineptus est et novus sibi*.

⁵ At this point in the Valencia text there is missing one folio, between folios 114 and 115.

⁶ Book III, chapter vi, p. 231.

behaves in this manner because, while she was being trained to come to the lure, a certain harmful practice became habitual; i.e., whenever she came close to the falconer, he threw her the lure. Now, when she is sent up to wait on and sees the falconer near her, she expects him to throw her the lure as usual. Consequently, as soon as she has left the fist and starts to circle overhead she turns toward the falconer, spreading her wings and waiting for him to toss out the lure. As the falcon thus waits on, she comes closer and closer to the falconer, hoping he will summon her. The fact that she is too lean and is, therefore, hungry is revealed by the same signs. But if the falcon is not hungry—merely too thin—she will move her wings slowly and weakly and, although she may attempt to mount, be unable to do so. Her circles are large because of the weakness resulting from her emaciation.

If a falcon flies low because of an obsession for the lure, or because of hunger, the falconer must make her wait on early in the day, when she is less hungry. If this does not help, then it is evident that she flies low only through her attachment to the lure—probably the result of excessive practice with that instrument. As a cure, she should be slipped several times at birds who try to make their escape by ringing up² instead of by flying swiftly away on a straight course. When she has been set free to capture such a bird but gives up the chase, she should be summoned with the lure-call and that decoy thrown out.

If it is discovered that hunger causes a falcon to fly low, then on the day before she is to be flown her usual ration should be divided into two portions and the larger part given her in the morning, while the smaller is reserved for the evening meal, so that on the following morning she will be less hungry.

If a falcon is too thin, then some slight addition must for several days be made to her

² Cf. Book I, chapter liv, p. 91.

usual repast, until she has returned to normal and flies as she ought to.

When low flight is normal in a falcon, send her up after birds who ring up rapidly,³ then let her fly at shore birds. This will show her that she cannot seize ducks as well from a low pitch as she can from a high one. In this way she will learn to wait on high over head.

CHAPTER XI

HOW TO CORRECT THE FLIGHT OF A FALCON WHO FLIES LOW AND GOES TO PERCH NEAR BY

A falcon of the third class, i.e., one that flies low above the falconer for only a short time and then settles close to him, does this because she is tired out and is unable to make a sustained flight, because she has become domesticated through long association with man before her education in hawking was begun, or because of excessive leanness or as a result of some other weakness. If it is because she is too fatigued, then the symptoms will be the same as those of other exhausted falcons. She should then be allowed to rest until she shows signs of a return to normal. After she has rested long enough, let her fly up and wait on.

That her behavior is due to too much domestication may be suspected if she has associated for a long time with men during the period of her manning. In the way of treatment for this defect, let her chase birds that ring up, as in the case of the second class of falcons.

If it is discovered by the symptoms already mentioned that the falcon's emaciation causes her to behave in this fashion, give her the treatment prescribed for excessively lean falcons of the second class. If she is unable to wait on properly because of some illness, this

³ This sentence completes the material probably contained in the folio missing from the Valencia Codex.

will be discovered by the signs and symptoms discussed in the Book on Diseases of Falcons.¹ She must first be cured by the means there prescribed and then sent up to wait on. Generally speaking, this class of defectives should be taught in the following manner to circle high and to remain a long time in the air: When the falconer sees her circling about, he should not wait until she has gone to perch but should at once throw her the lure and from day to day increase the interval between these acts, so that she will finally learn to persevere in her waiting on. If, while in training, she comes down prematurely and settles near by, the falconer must move away, call to her, and wave his glove, to induce her to rise and follow him. When he sees her coming, he must not wait for her to settle again but must allow her to make one circle above him, then toss her the lure.

There is a ruse useful in teaching a falcon not to fly low and to remain a long time in the air without coming to earth, and that is to make her fly over thickets, or high, thick grass, where she is afraid to alight and, therefore, keeps high in the air for a longer period. When she has been waiting on for some time over such a place, the falconer should move away, calling out and guiding her to some open space where he can satisfactorily toss her the lure.

CHAPTER XII

ON THE EDUCATION IN WAITING ON OF A FALCON WHO GOES AT ONCE TO PERCH CLOSE AT HAND

The falcon of the fourth class, that does not wait on at all but at once settles on the ground, does this because of immoderate luring, excessive fatigue, too much domestication, hunger, or illness. If there is no other

¹ So far as we know, this book was never written.

apparent reason for her misbehavior, it is probably due to the fact that she has been given too much training with the lure. In all these cases she must be sent up in some grassy or bushy area, so that she may be broken of her inclination to settle on the ground. She should then be thrown the lure on suitable terrain and flown at birds that ring up to high levels. If she goes to perch because of fatigue, excess domestication, hunger, or infirmity, it will be recognized by the symptoms we have described, and she may be cured in the same manner as others who persist in keeping close to the falconer.

CHAPTER XIII

ON THE FALCON THAT FLIES OFF AFTER WAITING ON AT A HIGH PITCH

Falcons that fly away from the falconer must be treated in a fashion different from other hunters. Among them those that fly high but in receding circles do so for a variety of reasons. They may have been badly handled and therefore hate men; or, at the beginning of their taming, they were given too little exercise with the lure; or they may dislike the hood because they have not been properly broken to it and for this reason, also, they have grown to dislike men. Another cause may be that they are too fat.

If a falcon has been maltreated and abhors men for that reason, it will be apparent from the signs described in the chapters on the mishandling of falcons,¹ as well as by the symptoms described in the chapter on the falcon's fear of man.² The results of evil manipulation may be remedied by sufficient repose and the treatment recommended to counteract the falcon's dislike of humanity, such as feed-

¹ Book II, chapters lxxv to lxxvi, pp. 202-5.

² *Ibid.*, chapter lix, p. 179.

ing her titbits, caressing her, and otherwise encouraging her to try to please her master.

If in her wild state she was not given sufficient luring exercise, she should be trained with a decoy and properly trained to come to it. When she has reached the educational stage, where she can be made to wait on, the falconer should continue her instruction as follows: After she has been called to the lure and has come near enough for it to be thrown to her, the falconer holding it should suddenly hide it. The falcon will then remain above him, circling about and waiting for him to toss it out. After she has made a couple of circles, he should let her have it, not delaying too long lest she fly away before he has thrown it. He must then praise and reward her in whatever manner he can, e.g., feeding her with good meat. This exercise must be repeated for several days, each day making the falcon remain a little longer in the air. After this, whenever the falconer wishes to send her up to wait on, he should feed her morsels of meat from the lure and then let her fly at once. In this way there will be no delay during which she can forget the titbits and fly off. When he slips her he must use the call reserved for waiting on. This cry will tend to prevent her from flying away from him. After the falcon has made three or four circles and while the falconer is directly beneath her is the proper time to toss her the lure.

It is easy to decide whether hood-shyness is the cause of the falcon's flying off. If it is, she will not support patiently either the adjustment of her headgear or the wearing of it. To cure her she must be made to the hood in the manner we have described in our chapters on the hood.³ When she has become reconciled to it, she should be lured for several days; and when the time has come to teach her to wait on, the falconer must call her to the lure, hide it as she flies down close to him, and then continue his operations in ac-

³ Book II, chapters lxxvii to lxxx, pp. 205-19.

cordance with the directions we have already given. When she is sufficiently trained to send her up to wait on without calling her to the lure,⁴ she must be allowed to taste the meat on the lure before being slipped. Then proceed as before.

If it is suspected that obesity causes her to fly away, this condition will easily be ascertained by feeling her and by other indications we have mentioned. In any event, before she is sent up to wait on, she should be reduced to a proper leanness. Then she must be called to the lure and made to circle overhead in the manner before described.

CHAPTER XIV

ON TWO CLASSES OF FALCONS THAT WAIT ON AT A LOW PITCH AND THEN FLY AWAY

The second class of falcons who desert the falconer is composed of those who fly low. The reasons for this behavior are the same as in the first class. These birds must be taught to remain with the falconer by the same means we have set forth in discussing the falcons of the former group. After they have learned to remain near him, in order to teach them to wait on at a higher pitch, they should be sent up in a grassy or bushy area and given such other training as we have suggested for that purpose.

The third group comprises those falcons who circle low for a short time only and then leave the falconer altogether, to come to rest a long distance away. To each falcon of this group must be applied the remedies indicated by the cause of her unsatisfactory behavior. Nevertheless, since her conduct is worse than

⁴ In the first instance the assistant holds the falcon while the falconer calls her to the lure; in the second, the falconer himself slips the falcon to mount and wait on.

that of falcons of other groups (probably because she is more seriously afflicted, or because of ill-treatment and other causes), greater care must be taken in dealing with her.

CHAPTER XV

ON FALCONS OF THE LEAST VALUABLE CLASS WHO DO NOT WAIT ON BUT FLY AWAY TO PERCH AT A DISTANCE

In the fourth group of this category are those falcons that do not circle at all above the falconer, those who immediately avoid him, and come to earth a long way off. Since these falcons are the worst of all, the most careful attention is required during their cure in order to teach them to wait on and to remain near the falconer. If a falcon¹ of this class settles at a distance, the falconer must call her back and whirl his lure. When she approaches he must hide the decoy and, after she has made two or three circles overhead, he must throw out the lure and feed her.

Those falcons that do not wait on at all but fly off at once to hunt small birds are the most objectionable of this whole class. This fault has its origin in the fact that while still wild the peregrine was lured but not thoroughly trained. Also, because of her wildness, the falcon who has not been long with man has not yet sufficiently forgotten her earlier flights at birds and still desires to chase them whenever she sees them. She has not grown so attached to the lure through adequate acquaintance with it that she will give up her pursuit of a bird she has been accustomed to hunt. For this reason the falcon should be thoroughly exercised with the lure for several days. Thereafter she must not be sent up to wait on where there is avian quarry, especially birds she has chased before.

¹ The Bologna text (fol. 132, col. 1) gives *falconarius*, but the Mazarine Codex furnishes *falco*.

If it is not insufficient exercise with the lure but merely a courageous spirit that impels the falcon improperly to pursue a bird the first time she is sent up to wait on, then she must not be flown again where there are such temptations. Should she fly off even though she sees no visible quarry (in order to hunt for it), she must be cured of that defect by the means used to correct those falcons who fly high but desert the falconer; and she must be exercised with the lure to induce her to remain near her owner. When she pursues a forbidden bird the falconer must follow her, calling out as long as he sees her. And if, by reason of the call or any other cause, she abandons her chase and turns back toward the falconer, he must toss her the lure as soon as she is above him; then he must take her up and feed her, as before. If, however, she flies so far away that he loses sight of her, the falconer must swing the lure and call to her in a loud voice. If the falcon catches a bird and the falconer is able to reach her before she has fed upon it, he must remove it from her talons and not feed her at that time but carry her back as quickly as possible to the spot whence she was first sent up to wait on, and there he must send her up again. As she is now tired from her exertions, it frequently happens that she will not again fly off. If she remains close at hand, let her have the lure and food. If, however, she again disappears, repeat the operation each time she does it, whether she feeds little or much. If she takes even a small amount of food from her quarry, give her nothing more to eat that day; but on the next send her up to wait on. If she consumes a large amount of meat, reduce her diet for several days, the quantity on each occasion depending upon how much food she has previously taken. Then exercise her with the lure, and afterward send her up to wait on. Repeat this as often as necessary to teach her to remain near the falconer and not to desert him.

To avoid the proximity of man is natural for a falcon; to remain near him is decidedly unnatural. It is, in fact, easier to elicit from the hunter an instinctive reaction to normal stimuli than to induce her to respond to artificial incentives. Nevertheless the falconer is able to accomplish much, despite the influence of the ordinary forces that impel a falcon to avoid and to fly away from men. These latter are more numerous than any attractions that might operate to make her remain in their company. Bad weather, unusual and unsatisfactory surroundings, the innate desire to soar high aloft, to chase birds, her dislike of birds that may mob² her—of eagles and other birds that she fears—and still other causes—these unite to draw her away from the environment of men. There is, on the other hand, only one satisfactory means of persuading her to remain near her master, and that is to arouse in her a love of the lure. This is why the least praiseworthy type of falcon who stays near the falconer is far more useful for the purposes of sport than the best of the four classes that fly away. Any falcon who willingly associates with man, whether she flies high or low, will be of some use to the falconer; but the falcon who goes off by herself, whether her flight be low or high, is of little value to him.

To review the foregoing remarks: All that is required in the case of the falcon that settles down near the falconer the minute she is sent up to wait on (i.e., the least desirable of all that class that associates willingly with man) is to make her wait on over the falconer's head by the means we have described. She is already willing to associate with him because of her domestication and affection for the lure, for these conditions have become second nature to her. Through frequent and habitual calling to the lure, exercise therewith, and feeding thereon, the forces (which we have mentioned) that drive the falcon away from

² *verberare*.

men will cease to be operative. Even though the falcon may follow her instincts, she will quickly learn to respond to the call of her master.

Although a falcon that flies high but goes astray from the falconer can be induced by artificial means to remain near him, nevertheless the causes that make her leave him readily come to the surface. It is natural for a falcon to fly off; and, when she has done so, it is far from easy to bring her back—such a result is contrary to her own feelings and purpose. It is therefore evident that the least valuable type of falcons who remain with the falconer is preferable to the best of those that fly away from his neighborhood. Since the three other groups of the first class are more desirable than the fourth, they are that much more valuable than the last three groups of the second category; hence the latter are the least coveted of their class. All falcons of the first category, i.e., those who associate willingly with man no matter what other flying characteristics they may show, are preferable to any type of falcon who will not remain with her master no matter how well she flies. It is this fact that we wish expressly to emphasize.

CHAPTER XVI

ON THE SEASONS, HOURS, AND WEATHER BEST SUITED TO HAWKING AT THE BROOK

We have spoken of education in waiting on as partaking partly of the nature of luring and partly of that form of hawking that is accomplished by means of falcons trained to wait on; and we have shown how falcons can be taught to perform this feat in their best style. It now remains to discuss the actual hawking to be accomplished by these falcons after they have been thoroughly instructed.

As falconry flourishes in its most attractive form with favorable weather and a suitable

environment, let us again discuss these conditions. The season, the weather, and the hour of the day must all be taken into account. The season must be considered in connection with geographical conditions. In hot regions summer is not favorable for flying a falcon at the brook; because at that time she drops her feathers early (moults) and is less able to endure extreme heat. Moreover, aquatic birds of such regions are scarce in summertime. Furthermore, in summer the greater the distance from the sixth climatic zone and the closer to the southern part of the third zone, the less favorable are these regions for this kind of falconry, owing to the intensification of the hazards just mentioned. These same districts in winter are much more auspicious.

The exact opposite is true of very cold climates, where, in winter, snow covers the face of the earth and frightens the falcon; moreover, the waters that offer favorable hunting are frozen over, and birds that make suitable quarry are gone. They have flown to larger bodies of water and to swamps with springs in them that do not easily freeze. In such weather falcons become sluggish and are unable to withstand the intense cold. Indeed, the farther one travels from the beginning of the sixth zone and the nearer the end of the seventh zone (and especially the region that lies beyond it), the less favorable is it for hunting in winter because of the consequent increase in adverse conditions. In summer, as we have said before, these cold areas offer more favorable opportunities for sport than a very hot terrain.

In spring and autumn falcons may be flown in both warm and cold regions, for the climate is then temperate.

As for the kind of weather that is favorable or unfavorable, as well as the proper hours of the day for hunting, it is always best to keep to those deemed most advantageous for sending up a falcon to wait on.

CHAPTER XVII

ON VARIOUS LOCALITIES WHERE HAWKING AT THE BROOK MAY BE PRACTICED

There are various localities in which men are in the habit of hawking at the brook;¹ among them we find small pools of still water, called basins,² also ponds and areas called by some falconers fens;³ as well as courses of flowing water, i.e., streams or brooks—all of which vary considerably. Not all of them are advantageous for falcons, especially for novices that are recently entered to game. It is often difficult to say which resort will best suit a particular falcon, for the same conditions are not alike favorable to all novices. It must be remembered that, as we have already shown, birds in training have different methods of waiting on. Consequently we must choose from suitable regions the environment most favorable for each type of flier.

Some people maintain that the areas called fens are best for novice falcons, while others claim that streams are preferable; but their arguments are too general and we do not always agree with them, just as we dissent when it is said that one kind of food agrees or disagrees with everyone. A dietary must be differentiated and assigned according to its qualities and the requirements of the recipients. Therefore it is especially desirable to emphasize the rule that flats, or fens, are not appropriate for all falcons; nor are streams, fens being more suitable for certain falcons and streams for others. Some falcons may more readily be flown over larger bodies of water than others, because not all falcons have the same mode of flight. Indeed, it is true that not all falcons who have unsatisfactory, or even bad, flying habits can be trained to

¹ Duck hawking, in particular.

² *Piscina*, "fish-pond," or "swimming pool."

³ *Plactere*, "flats" or "level ground covered with shallow water."

fly in a better style. For this reason fens are not suitable as a hunting habitat for every falcon; and the same truth applies to streams.

The flight of falcons varies as much in hawking at the brook as in waiting on; and for this reason we must describe the various forms of flight and other methods adopted by them over water, so that we may allot to each hunting bird her proper environment.

CHAPTER XVIII

ON THE MODES OF FLIGHT EXHIBITED BY PEREGRINES HAWKING AT THE BROOK; AND OF THE ENVIRONMENT AND ROUTINE REQUIRED FOR TESTING FALCONS

As we have said, falcons fly at game in various ways: some enjoy flights at ducks and are not afraid of water; others like ducks but fear water; still others have no fear of water but will not hunt ducks; while a fourth class both dislike ducks and fear water.

The majority of peregrines that are born in frigid regions enjoy duck hawking and have no fear of water. Water is usually abundant in cold and temperate climates, so that they have lost their fear of aqueous accumulations; also water birds are numerous and falcons are accustomed to feed upon them. Hence ducks are their natural prey. Peregrines who were not born near the sea or some other large body of water are most likely to be those that like ducks but dread water, mainly because they are not accustomed to large aquatic bodies; yet, as there are few birds in those cold regions other than waterfowl, they feed upon the latter and learn to enjoy their associations.

As to falcons that do not like ducks and are not afraid of water, they belong, as a rule, to a variety of noble falcons and were probably born in a warm climate near the sea or other large body of water. In such localities there are not many water birds in summertime and the falcons there, when young, were

not fed on them. To repeat: As they were born near the sea they do not fear water; and as they were not, early in life, fed upon ducks, they are not fond of them. If these falcons are peregrines, their dislike of waterfowl is probably due to the fact that they have been long in captivity. Perhaps they experienced a prolonged period of manning before they were taught to hunt, and were lured excessively before they were flown at wild birds. There are, thus, two common circumstances to account for their dislike of these birds, viz., they have been both manned and lured for too long a period. A third reason is that too long a period, also, has elapsed since they have captured a wild bird and the love and habit of going to the lure is stronger than their memory of bird hunts. Even though avian quarry rises beneath them when they are first sent up to wait on, and ducks are flushed for them, they do not care for them; they neither stoop to them nor chase them; they cherish the hope that, instead, the lure will be thrown out.

Falcons that are not fond of game birds and fear bodies of water are usually noble falcons born in the mountains far from the sea, large lakes, or wide rivers, where there are no aquatic birds for them to feed upon. To repeat, since they were born in mountainous regions far from water, they fear it, and they do not like ducks because they are not accustomed to eating them. It will be noted that falcons belonging to all these four categories display their distinguishing characteristics in more or less marked degree.

We have described the habitual characters that various falcons exhibit when entered to waterfowl at the brook. With such knowledge in our possession we may now add an account of suitable environments and the routine adapted to their particular habits. Studying these subjects helps us to safeguard our birds from untoward practices and to aid them to choose a desirable routine.

When a falcon has been sufficiently trained in waiting on and the falconer is about to enter her to birds, let him now consider weather and environment. The weather we have already discussed. As to environment, the falconer must choose an open area where there is a supply of ducks frequenting small bodies of water—ponds, fens, or streams. It is not possible in a specified instance to say whether or not such streams or ponds are really desirable resorts until we know how our falcon flies when entered to wild birds. But the place chosen for practicing must be far from any of the obstructions mentioned as objectionable in the chapter devoted to waiting on. One must also note whether or not a wind is blowing. If there is no breeze, let the falconer, accompanied by one companion to assist him, approach the place where the ducks are located. Two men are enough at a stream or pond (more are superfluous), and they must be careful not to put up the quarry sooner than desired, either by the sound of the falconer's voice or the noise made by a horse's hoofs.

Before sending the falcon up to wait on, the falconer must remove her hood and allow her to perform her usual preliminary acts. He must give the same care to the manner of slipping her as when teaching her to wait on. He must try when slipping the falcon from the fist to prevent the ducks from seeing the latter as she rises in flight, also to guard her from a view of the ducks before she is slipped; otherwise she might not rise and wait on but go straight after the quarry, causing them to fly off at sight of her.

The signs or indications manifesting, before a falcon is slipped, that she has seen some bird of which she is afraid (either circling aloft or passing at a distance) are these: She stands with her neck extended, her wings drawn close to her body, her tail feathers contracted, and all the rest of her plumage flat against her body. She crouches down (on the fist) in the belief that in this position the

eagle circling overhead, or on passage, will not see her so well. She will then shake her tail and look up fixedly, first with one eye and then with the other. And if she sees her enemy circling low near her, or passing close by, she will cry out and bate downward, releasing her hold of the falconer's fist in an effort to escape. These acts will be more sudden and strenuous if she sees the eagle approaching her from behind. If she notices one on the ground she will draw in her feathers and extend her body in a desire to examine and, perhaps, attack it, fearing lest the predatory enemy see her and assault her while on the fist. She wishes to initiate the attack and overcome her foe while it is standing on the ground in order that she may not herself be overpowered.

When a falconer sees that his falcon is looking up and giving signs of being afraid, he must at once look in the direction of her gaze to see what bird it is that she is staring at. If it is one she naturally fears, he must not let her go; for if it is a vulture or some other large bird that is an object of terror to her, the mere sight of it might, if she were allowed to fly, cause her serious injury. And though one must be careful not to fly a falcon when her enemy is at a high pitch, it is even more important not to let her go when the foe is low down and above her. If it is an eagle that frightens her, especially as it may harm her, she must not be released; for there is danger of misfortune not only from the fright she suffers at the mere sight of the enemy but also because it may pursue and attack her. Again, special care must be taken when the adversary is flying low; for the falcon's fear is then increased, and more serious damage may result. Although a less timid falcon gives only slight evidence of her fear on seeing an eagle, she must nevertheless not be allowed to fly. For if she is flown, the hostile bird may attack her. Even if it does not, after the falcon has pursued and seized

her prey, the eagle will hardly be able to restrain its instinctive impulse to descend and carry off the quarry.¹ In doing so it will probably injure the falcon, and even though it does not damage her physically she will be so frightened that she may fly off and be irretrievably lost.

When a falcon sees a vulture at perch, the falconer should chase it so far away that she no longer fears the sight of it. On the other hand, an eagle should be driven much farther away; for though a falcon fears a vulture, the latter will not approach her, as will the predatory eagle, who must be driven not only so far away that the sight of it will not cause alarm but to such a distance that the larger bird of prey cannot see the smaller one and be tempted to attack it.

CHAPTER XIX

ON FALCONS THAT RAKE AWAY BEFORE DUCKS ARE PUT UP

When the falcon has been slipped to hunt ducks and has begun to wait on over the falconer, she will either remain there until the ducks are flushed or she will fly away before this is accomplished. If she keeps her position overhead, then ducks must be put up in the manner we shall describe later. The falconer's main purpose is to hold her above him, waiting on at as high a pitch as possible, while he raises ducks for her as often as necessary. The falcon is then in the best position to stoop at the ducks and to take one of them.

If the falcon does not remain above the falconer but moves off before the quarry is put up, he must strive to draw her back to a point where she is once more directly above him. Unless she is over the ducks, waiting on as she should, it is not possible to put them up in a fashion that will assure success. In or-

¹ *vix possit se continere aquila quin descenderet ad auferendum sibi praedam.*

der to recall the falcon it is well to understand the probable cause of her flying away, its manner, and, in general, what forms of desertion are the worst and why. The falconer must also learn how he can best reclaim the errant falcon; and this result will depend mostly upon the causes of her flight. The possible reasons are numerous: She may abandon the falconer because of some man whom she has noticed riding or walking in the fields; and this interloper may be one of the falconer's own companions. She may chance to see a bird and follow it in an attempt to catch it; or she may even go off to perch¹ (especially if she is a novice and finds herself near a suitable resting place), for she is unaware of any good reason why she should continue to wait on. She may also fly away because she has been unable to catch her prey on the wing and is tired out by the effort; or she may not be tired but be afraid of the mere sight of some other bird, such as one that is in the habit of seizing falcons. Of all those birds that are a menace to falcons, we shall later give examples and speak more fully on this subject, in an appropriate place.

Falcons respond in several ways to the situations or motives that make them retreat from the position of waiting on. Under the first three conditions already listed they go of their own free will and desire, but depart reluctantly for the last three reasons. We say that the falcon has left spontaneously when she has not been induced to do so by fear or fatigue brought on by other birds. We also affirm that she goes reluctantly when the contrary is true. There are three subdivisions under voluntary abandonment of the falconer that correspond to three motives, and three more under the classification of involuntary departure, and these are related to the remaining three incentives.

¹ The Bologna Codex (fol. 134, col. 2) says *aut solum nō vadat ad sedendum* but should be read *v'o vadat (vero vadat)*.

CHAPTER XX

ON THE CAUSES OF A FALCON'S RAKING AWAY, AND ON THOSE THAT HAVE THE MOST SERIOUS RESULTS

Some classes of defection are worse than others. What they are and why some are worse than others we shall now relate.¹ When a falcon leaves her position above the falconer to visit somebody she sees in the fields, the falconer can easily follow her and is not in danger of losing sight of her, because her one idea is (especially if she is a novice) that the first man may toss her a lure or put up some bird for her. This last expectation results from her knowledge of how to capture birds on the wing. As she is not in pursuit of some quarry in flight before her, she does not move swiftly but flies slowly. She is not going far, nor does she become tired in her flight. In fact, when she reaches the man first mentioned she will wait on above him, hoping he will throw her the lure. This act is all the more likely when he is on foot, because her first training with the lure was given her by a pedestrian. If he is a horseman, she will wait on in the belief that he will send up a bird. As the falcon circles above him, since he does not call to her, wave his glove, toss out the lure, or perform any other act to induce her to remain above him, she will find that she has been mistaken and will soon return to the falconer who is following her. He is the one that calls to her, waving his glove. As she has a short distance only to travel upon her return, she will accomplish this quickly, gladly, and without fatigue. When she has (by these means) been brought back, the falconer may very well fly her at water birds, putting up ducks for her. The man over whom she waited on, if he knows anything about fal-

conry, will use his knowledge to assist her return by running, or riding, toward the falconer who is following her. But a horseman is the only one that can be of real assistance; a pedestrian is of little practical use, as he cannot move swiftly enough toward the man seeking the falcon.

When a falcon ceases to wait on simply because she wishes to go to perch, it is more serious if there is no apparent reason for this desire or if she does it merely because she has seen a place suitable for a rest. If fear of an avian enemy is the cause, then there is no fault of the falcon involved, except that many falcons become timid in the presence of such foes. This defect is less serious than if she were to indulge in a prolonged chase after some (illegitimate) avian quarry. If she flies off and goes to roost somewhere—a practice that may become a habit—because she is weak from emaciation or disease or because she has been ill-used, the condition is worse than if she were to follow a bird a long distance; for when a falcon makes a lengthy pursuit of this kind she shows a bold, adventurous spirit, much strength, and sound health; but when she goes to perch (for no apparent reason), she displays a weakness that is the very opposite of these qualities.

If a falcon abandons the falconer because of some bird who frightens her and whom it is not her habit to catch, it is more serious, especially if she is naturally timid or is a novice. A young falcon is easily diverted by the advent of hostile birds; indeed, a novice who does not know why she should wait on is easily induced to desert her master by almost any diversion. The tyro does not know what course to pursue and is timid because of her natural fear of birds. For example, certain birds threaten to mob her, with the result that she sometimes goes to perch and sometimes flies so far away from the falconer that it is difficult to entice her back. The farther she flies the worse it is; and even though

¹ Bologna MS., fol. 134^v, col. 1, *n̄* (*non*) *dicatur* must be read *n̄* (*nunc*) *dicatur*.

(through the efforts of the falconer) she returns, she is scarcely able to hunt because of fatigue caused by her avian enemies. But this is not the worst consideration: she not only may be unable to hunt when called upon but, if she is not partial to the lure, may get lost. This is especially true if the hour at which birds interfere with her is near the middle of a hot day; she may then become so exhausted that she easily goes astray.

The position is even worse when she rakes away to chase some bird that she chances to see. Its seriousness will depend upon the avian species she pursues, as well as upon other considerations, e.g., its manner of flight. When she chases a bird chiefly because of her keen desire to catch it, and when that bird, exerting all its efforts to escape, is a tireless and swift flier, the falcon will have a prolonged pursuit, during which she may be carried far from the falconer, who can with extreme difficulty follow her and may soon lose sight of her. Since the errant falcon hopes eventually to capture the prey, she has no incentive to return to the falconer while the chase continues nor will she quickly reappear, because of fatigue. As she has covered a long distance in her flight, her return journey also will be long, and her restoration at a late hour may be preceded by untoward incidents, previously mentioned, such as meeting rising ducks or other quarry (that she chases), the interference of eagles, or birds that mob her. As one result of this adventure she may succeed in taking a bird and, perhaps, in feeding upon it. In consequence she does not come back at all but is lost, because her chief incentive to return is her hope of being fed when she is hungry.

If a falcon does not catch her bird and the falconer's efforts to recall her at once are unsuccessful, she will be so thoroughly worn out by the exertions attendant upon her long flight in pursuit of her prey and by her protracted return journey to the falconer that

she will be of no real use for hunting. For this reason such a variety of desertion is worse than any of the foregoing.

When a falcon ceases to wait on because of the mere sight of some bird that does her no harm but of whom she is afraid, such as a vulture or lammergeier,² even though she does not flee before it but instead rings up (in defense) to tower above the object of her fear, and although the falconer is not obliged to ride far in following her and can easily take up a position beneath her (because she soars high in circles and does not move far from her master and therefore is not easily lost sight of), nevertheless the situation is very bad because her fear of hostile birds makes it difficult to recover her by means of the lure or any other device. Moreover, it frequently happens that under these circumstances she is lost, especially if she is by nature timid. On the whole, this manner of deserting the falconer is fairly serious and, because of the fright the falcon experiences, it is sometimes even worse than the kind we have just described.

When a falcon has flown away because of some rapacious bird that is accustomed to capture falcons, such as various species of eagles, the consequences are the most serious of all. The eagle chases her with the intention of catching and feeding upon her. She is terrified and flees, raking away at the greatest possible speed to escape from her pursuer. The falconer cannot possibly follow, and quickly loses sight of her, so that she easily and permanently goes astray. Even though she is not altogether lost to view and the pursuing eagle gives up the chase, and though she may still see the falconer and follow him after the eagle has departed, she will not willingly return to the spot whence she has flown because it is there that she suffered her fright and from which she was chased by the eagle. Often she will merely soar high to get above

² *Ossifragus*.

the eagle, or else she will hide herself where it will be most difficult to recover her, by means of either the lure or some other device, because of the fright she has experienced. Her behavior, under all these circumstances, will, to a large extent, depend upon the degree of her terror.

CHAPTER XXI

HOW TO DETERMINE THE CAUSE OF THE FALCON'S RAKING AWAY

Even though a falconer cannot see the errant falcon he can frequently discern the reason for her defection. If she goes off after some man, she moves her wings slowly (more deliberately than when she is lured) and flies higher, the better to watch the individual and whatever it is she hopes to receive from him. If she goes to perch, she will proceed slowly and fly low. If she deserts because of birds that annoy her but of which she has little real fear, the falconer will easily perceive the trouble, because while she is waiting on he will take note of the offending birds, such as ravens, crows, and their like, who either mob or seize the falcon by the jesses and make themselves more or less of a nuisance. When she flies in pursuit of some prey, she moves her wings rapidly and flies swiftly, intent upon the quarry, whom she pursues at an elevated pitch, especially when it is a species that soars high. If it flies low, she follows on its own level and adjusts her speed to that of the fleeing bird. If her precipitate flight is due to some hostile eagle, flying near at hand but above her (even though the falconer may not see it), she will spread her tail, shake her feathers, and attempt to escape, turning her head first to one side then to the other, to keep an eye on the enemy she fears and is attempting to elude. If she rings up to soar aloft because of circling eagles, vultures, or lammergeiers, she gives the aforementioned

signs of fear and indications that she desires to soar. As noted, the signs of fear are more or less marked, and their character will depend upon the proximity of the eagle or other avian object of terror, as well as upon the inborn timidity of the falcon herself.

CHAPTER XXII

HOW TO RECOVER A NOMADIC FALCON

Let us now explain the proper method of recovering a nomadic falcon, no matter what the reason for her desertion. Beginning with the first cause we gave of this defection—when the falconer realizes that the falcon has flown off to join some other man—he must call to her and wave his glove in an attempt to recall her. If she does not then return to her proper position above him, he must leave his companion, if he has one, and himself follow the falcon, calling her with the proper cries. The mere fact of his presence may bring her above the falconer's head. Even when he has no assistant, he must nevertheless follow the falcon, but not at a rapid gait, because the falcon is flying slowly and there is no need to ride fast after her; he must be careful only not to lose sight of her. It happens frequently, since the falcon is not chasing a bird, that she will come back at the sound of the falconer's voice or at the sight of the waving glove. Were the falconer to travel too fast, however, he would soon be some distance from his assistant and from the chosen locality where ducks are found. In that case the falcon, on her return, would arrive before him, since she travels faster than a horseman. The falconer would not then be on hand to help the bird or his assistant in the approaching hunt. On the other hand, should the falconer's associate, who has remained near the quarry, delay in putting up the ducks until his superior returns, the falcon might grow tired of waiting on so

long, and something might meantime happen to make her fly off again. Therefore if the falcon arrives on the scene and circles about above the companion before the return of the falconer, and while he is still some distance away, the former must wait no longer but at once put up the quarry in the manner we shall describe. In this fashion the falcon will at least be kept waiting on. If the environment is such that he can so dispose matters that the falcon can capture a duck, let her do so; but even if the hunter is not likely to make a seizure of the prey, the assistant ought to put up the ducks. The falcon will then see that there is quarry present and will have an inducement not to desert again but to wait on until the falconer comes. If the ducks are not put up at this time, the falcon, seeing no reason why she should remain overhead, may fly off. She may be tired of useless waiting on, or she may desert because of the intervention of some bird she fears or wishes to catch or that simply annoys her, or for some other motive.

Should the falconer who went in pursuit of the falcon be out alone but return quickly after the falcon has preceded him on return to the rendezvous of the ducks, he must decide whether or not to use the cries that help to prevent her from flying away again. If he does call out in that manner, it may result in bringing the falcon toward him and thus causing her to abandon the ducks. He will then be obliged to guide her back to her quarry, and this going and coming may well confuse and tire her out, with the result that even though she responds to him at a high pitch she will soon lower it because of fatigue and be less effective in future hunting. On the other hand, if he does not call out, the falcon, having no reason to remain waiting on, may fly off because of fatigue or some fortuitous circumstance. For these reasons it is necessary to have two men take part in this form of hawking. Also, if the man who follows the falcon is alone, he must not ride very fast

after her, unless he is afraid of losing her from his sight, but should be as quick as he can when following her back to the place where the ducks were first found, lest she arrive too long ahead of him. He must not call out too frequently—only often enough to keep her waiting on until he arrives to put up the ducks and to perform other necessary tasks. If he notices that she is about to fly away again, he must make an outcry sufficient to overcome her desire to carry out that intention.

If the individual for whom the falcon deserted her master is properly versed in falconry, he will, as soon as he sees her waiting on above him and observes the falconer coming after her, move toward the latter so that the falcon will follow him. A horseman can do this more easily than a pedestrian, but he should go no farther when he sees that the falcon is at last in her proper place above the falconer.

When the falcon returns, if she does not go straight to the falconer but approaches to one side (not hearing or seeing him), and if she comes back alone and not in pursuit of some bird, then the falconer must turn and ride across her path of flight, calling out and waving his glove, to lead her back to the ducks in waiting. Should she be in pursuit of a bird and fly toward the place where the ducks are, then, before she passes over, the assisting falconer (stationed there) must put up the ducks but must first call out to attract her attention, so that she will look below her, see the ducks, and give up her pursuit of the other bird. If it is noticed that in following her self-chosen quarry she flies to one side, the assistant falconer must call out and wave his glove, especially if the prey pursued is of a variety that mounts high by ringing up. But if the falcon is going after a bird that flies swiftly on a direct course, or if for any other reason the falconer fears she may go astray (because his calling out and glove-waving are ineffec-

tive in making her give up the chase and change her course), he must not permit her to pass him but must call her down to the lure before she disappears. It is better to take her up at this time and, if she is willing, slip her later at waterfowl than to run the risk of losing her.

If a falcon goes to perch, the falconer (before she has settled somewhere) should try, by cries and glove-waving, to keep her above him. This he must do whether she goes off because she spies a desirable roosting place or because she no longer wishes to wait on. He must move from place to place while forcing her to rise again. If he is unsuccessful in this attempt he should display the lure and make her take to the air. When she has done so, he must, by calling out and waving his glove, guide her back to the place where water birds are resting.

CHAPTER XXIII

ON THE MODES OF FLIGHT OF BIRDS THAT CAUSE A FALCON TO RAKE AWAY

As soon as the falconer sees that his falcon is raking away after some bird, he must at once determine its species, so that he may as far as possible regulate his pursuit of the falcon and other behavior in accordance with the characteristics of that species. He must also be informed as to which birds are most likely to be the cause of his losing a falcon. Birds of different species have different methods of flight. As we have explained, some birds fly high, some low; some birds accomplish long flights; others only short journeys; some birds are swift fliers, while others move slowly. Of those that fly high, some ring up to gain their pitch, while others do not circle at all but rise higher and higher, on a long, straight course. In some species these characteristics are very pronounced, and in others less so.

When a falcon pursues a bird that rings up, such as the long-eared owl,¹ the hobby,² and others, the situation is not serious. Nearly all birds that circle while rising in the air are slow on long flights, and a falcon ringing up soon overtakes a bird of such a species. As she continues to chase her prey, the falconer may ride with ease to a point beneath them and not lose sight of the hunter as she soars above him. Since the pursuit of one of these birds teaches the falcon to climb to a higher pitch than she attains when flying alone, a flight of this kind is not only not detrimental but is actually useful. When the falconer coaxes a falcon back after such a flight, he can easily induce her to take a more advantageous position directly over the quarry. Therefore when a falconer sees his bird raking away after prey that rings up, there is no need to ride very fast after them; for then he might over-ride them both and produce the same evil results we cautioned against in the first case. And if the falcon is a novice and young, and consequently unwilling to climb to a high pitch, the falconer must not immediately recall her but must allow her to follow her prey and learn in this way how to ring up. In recalling her he can teach her to take a position high in the air directly over the waterfowl; but the falconer must be careful not to delay this project too long, lest she leave the bird she has been pursuing and fly off to some inaccessible spot.

If the bird the falcon chases is not one that gains altitude by ringing up, but rises gradually higher and higher in straight flight, the falcon will soon be a long distance from the point whence she was slipped; for many such birds are swift fliers, and the falcon must fly fast in pursuit. It is evident that a hunted bird will not pursue a straight upward course very long unless it thinks itself as swift a flier as the pursuer. The falconer, in consequence,

¹ *huanus*; Fr., *chat huant*.

² *albanus*; It., *albanella* (*Falco subbuteo*).

may lose sight of his falcon, and the distance she has flown will add to the difficulty of bringing her back. She will also be very tired from her long flight, back and forth, and less active in hunting. Hence the falconer must not delay in riding quickly after her and in making every effort to recall her; for, if he is slow in accomplishing this maneuver, one of the aforementioned accidents may occur.

The situation is serious, also, when the falcon follows a bird whose flight is low, long, and swift; for she is soon far away, especially when in pursuit of such rapid-flying quarry as ducks, plover, and many other aquatic species. The falconer can follow her at first, but because she also must fly low and close to the ground he may not be able always to see the pursuing hunter. Her proximity to the earth makes it easy to lose sight of her and, of course, more difficult to entice her back. She gets exhausted by her long and rapid flight away from the falconer and from the place whence she started. Moreover, since she flew low down on her outward flight, she may also return at the same low pitch. There is no advantage to be derived from this procedure. The falconer must therefore ride at once and swiftly after the falcon and bring her back as soon as he sees her chasing a bird that flies in this fashion.

If the low-flying quarry is one that executes only short flights, e.g., a pheasant or a partridge, even though it moves swiftly, the low pitch of this flight remains its sole objectionable feature. The falconer's view of the chase is obstructed because of the contestants' close proximity to the ground. When the escaping bird goes suddenly to earth, the falcon, believing she can capture it, will land near by and the falconer is thus unable to find his bird, because all the usual clues are lacking. Even if he swings his lure, the falcon cannot see it (from her position on the ground) unless by some chance he passes near her. This mode of flight is hurtful, also, for the falcon's

career because it teaches her to come to rest at the water's edge when she flies at a duck that seeks an aqueous refuge. She is especially in danger of acquiring this bad habit if she comes to earth frequently when in pursuit of avian prey that indulges in only short flights. This habit is detrimental, also, for the reason that the falcon's feathers may become so wet from the dew-laden or rain-soaked grass that, even though she manages to rise,³ she is unable to fly properly until her plumage is dry.

As soon as the falconer sees what is happening he should ride rapidly after the falcon, calling aloud, so that, even if the quarry settles on the ground, the falcon, hearing his voice and seeing his other efforts to recall her, will not make a landing but will turn back. If she does land, the falconer should not recover her at once with the lure but should make her rise by calling to her and waving his glove. After she is in the air he should encourage her to ring up and attain her normal pitch.⁴ When the distance to the point whence she was slipped is short, the falconer should lead her back and put up ducks for her. If her feathers are wet, however, he must throw out the lure and recover her. If she does not rise when he calls her, he should show her the lure, waving it at her, to induce her to rise, and then hide it in the manner previously explained.

CHAPTER XXIV

ON THE DISTRESS CAUSED A FALCON BY THE INTERFERENCE OF OTHER BIRDS

When a falcon that is waiting on flies away from the falconer because of birds that annoy her, he should note the species of the avian

³ The Bologna (fol. 136^v, col. 2) and Mazarine (p. 564) texts read *se levet*, but the Valencia Codex (fol. 226^v) gives *se levet*.

⁴ *permittat ipsum ascendere ad metam sui circumvolatus*, Bologna MS., fol. 136^v, col. 2.



PLATE 129.—Portion of the Palazzo Reale in Palermo, continuously used as a residence by the kings of Sicily for more than seven hundred years. The square erection is the oldest section of the Palazzo and contains the famous Capella Palatina and rooms occupied by the Emperor Frederick II.



PLATE 130.—Castel Trani, now a prison. It is typical of the “Castelli” built by the Emperor in most of the southern parts of his kingdom. Its walls facing the sea are twenty-seven feet in thickness.

mobsters and the manner of their interference, as well as the reasons for it. He should also observe what reaction the falcon makes to this intervention. He should also recognize when a falcon is more than usually timid in the face of such annoyances, and do what he can to assist her, in accordance with the nature of the trouble.

Birds that interfere with the comfort and usefulness in sport of falcons are of various kinds. Among them are birds of prey, both large and small, as well as large and small birds of other species. Of these there are at least three classes: those the mere sight of which alarm the falcon, such as vultures, lammergeiers, and eagles; those that mob her, but of which she is not afraid when she sees them, such as members of the crow family (they may include wild falcons and small birds of prey); and, finally, birds whom she dislikes on sight and whose presence tires her, such as kites and their relations, bustards, hobbies, and ravens.

Fear of vultures and of birds called "bone breakers"¹ (lammergeiers), which are not really birds of prey but live solely upon carrion,² whether they fly high or low over the falcon, forces her to desert the falconer, although these birds do not attempt to catch her or do her any other harm, since they do not subsist on live quarry. It is their size and resemblance to eagles that menace and frighten the falcon so that she flies away as soon as they cross her line of vision.

The sight of eagles and allied species is very disturbing to a falcon and impels her to leave her post above the falconer. This defection is even more pronounced when she is chased or attacked by one of these predatory species, for their purpose is to seize her and at times to prey upon her. Therefore she is afraid of all eagles, seeing in them a fearful, menacing evil before which she flees in terror.

Kites and their relations, bustards and hobbies, frighten falcons chiefly because of their resemblance to eagles in shape (though smaller than they) and in manner of flight. Part of the annoyance they cause is occasioned by the jesses they see on the falcon's feet, which they believe to be her prey. This belief leads them to pursue, attack, or strike her, and then to drag her by her foot gear. They do not actually seize her, and have no intention of doing so; but if the falcon has perchance taken some quarry, then their interference with and annoyance of her is all the more serious and determined, because these birds are accustomed to feed on the prey of other birds. Nevertheless the fright the falcon receives from the sight of such birds is probably more harmful than any actual physical outrage of which they may be guilty.

Lanners and other wild falcons, as well as the smaller species of raptors, also interfere with a trained falcon's duties because of her jesses, which they are certain is her quarry. This evil is even more noticeable in districts where these untamed birds pass the winter,³ because they are not willing to share their hunting grounds with other seekers of quarry. This is true especially at the nesting season, when they drive off all other (both tame and wild) falcons from the region they inhabit, defending it by chasing, striking, attacking, and seizing them in the manner described. The domesticated bird is afraid of them and flees from their molestation. The bolder and larger the species of wild falcon, the more they persist in disturbing and interfering with an educated falcon. If the latter has caught some prey, they carry their attacks to even greater lengths; for they do not hesitate to seize and feed upon the prey of others.

Although ravens are not in the true sense birds of prey, yet the fact that the falcon fears them is a drawback, inasmuch as these active and strong birds annoy her exceedingly. They

¹ *ossafragantes*.

² *carnes cadaverum*.

³ *yamar, (yemare?) hiemare*.

follow her about, calling after her, chasing and even attacking her with their claws and beaks, thus displaying their great dislike. As a result of these insults she flees before them.

The mere sight of crows and related species does not, on the other hand, alarm the falcon very much. She does not fly off until she is actually molested by them, when the distress they cause her by simply screaming at and chasing her makes her take to flight. This is true especially of a falcon that is naturally timid or has previously been much worried or actually attacked by birds resembling crows. Crows and ravens are most likely to behave in this manner during the nesting season, not merely from their natural dislike of falcons but in order to defend their breeding haunts. This practice they share with all other birds that are unfriendly to falcons.

Some particular hunter may display greater fear of all these hostile birds than another. In fact a timid falcon may be more afraid of the mildest of her enemies than the boldest falcon is of the most terrifying and dangerous of them. Moreover, some falcons are often intimidated by one single kind of bird they hate, perhaps because they have been injured by previous assaults of that particular species.

CHAPTER XXV

ON SIGNS OF DISTRESS IN A FALCON; AND HOW THE FALCONER MUST ACT TO PREVENT HER RAKING AWAY

A falcon that has been tossed from the fist will give the following signs of distress on seeing an enemy flying high above her or even passing at a distance. If it is an eagle she will rouse frequently, shake her tail, spread it wide, and ring up with the purpose of towering over the enemy. If she succeeds in this maneuver she will stoop at the dreaded bird, to prevent its rising in turn over her, as well

as to drive it from the neighborhood. But when she sees an eagle circling low or passing near by, if it is the stronger bird but shows no signs of attacking her, she will behave as in the former case, ringing up to get above her enemy. On the other hand, if an eagle stoops to attack her, she will retreat to the safest place she can find. If, however, the eagle appears to be weaker than herself, the falcon will pursue her adversary and strike, to prevent it from rising above her. Should an eagle be standing on the ground or perched on a tree, the falcon will similarly attack and drive it away.

When one of the aforementioned birds assails and harasses a falcon after she has left the fist, and the falconer notes signs of this intimidation, he must not wait for the falcon to fly away but must recall her at once. If he delays in this precaution until her flight has begun, her fear may render her unwilling to come to the lure and, if he cannot follow her properly, he may lose sight of and fail in his search for her. After a falcon has been worried by birds that frighten her, it would be useless to fly her at ducks; for she would be unsuccessful in that venture. If she is not taken up at once, she may be further annoyed by her enemies and rendered still more difficult to recover. Lest she be altogether lost, the falconer must not delay in retrieving her. Let him call to her, throw her the lure and take her on his fist. When, on the other hand, the falconer sees from her behavior that a falcon is not afraid, he should not try to recover her at once but should serve her with a waterfowl. And this he must do sooner than if there were no birds present to annoy her. This is, of course, done to prevent her flying off. Her partiality for ducks will cause her to remain, and the birds that cause her distress will hurry away when they see the falconer running and shouting to put up the quarry.

When the falconer perceives that the mere sight of a bird she fears causes a falcon such

terror that she gives signs of raking away, he must not wait until she has gone some distance but must recall her at once, summoning her to the lure in the regular manner.

If the falconer sees that the interference of lanners and other falcons does not greatly bother or worry a falcon, that her attention is not thereby distracted from him, and that she does not show signs of going off, he should not call her down but should encourage her to capture ducks. If, however, she is so worried and distressed that she is forced to turn her attention away from the falconer and threatens to rake away, he must call her to the lure and take her up. The foregoing is true also of smaller birds of prey, and the procedure to be followed is the same.

When, after the falcon has left the fist, ravens appear and start to mob her, or she becomes frightened and shows signs of distress on seeing them, she must at once be recovered; but if she is not much disturbed and is not really frightened, the falconer should flush the quarry and proceed as prescribed.

When crows that annoy the falcon appear, but she does not seem to be much afraid of them (because they do not greatly bother her or chase her so far away that she may be lost), the falconer must not hesitate to put up the ducks. The worst trouble that crows bring to a falcon is that induced by the screaming of one or more of them, as a flock joins in mobbing her. It is their noisy numbers that cause her genuine anguish. If, however, a very timid falcon is so much harassed by corvine foes that she cannot be kept close to the falconer by resorting to the usual devices, she must be taken up.

Crows annoy falcons in two ways, one of which has been described. The second occurs when a falcon pursues her tormentor in an attempt to seize it. This is a rare event in the case of most birds that distress her, because, although a falcon will sometimes pursue an eagle or a vulture, she has no intention of

capturing it but on account of her hatred and fear desires to drive off the enemy. When she chases a crow, however, she does so not merely to drive it away but to capture the troublesome creature. This is more dangerous than the pursuit of any other bird, since crows are found more frequently and in greater numbers than other foes and for that very reason are more of a nuisance and danger to falcons, especially to those that are in the habit of catching them or that like them as food. For that reason the presence of crows is even more harmful to branchers, for a larger number of these young falcons are accustomed to feed upon them, especially in cold regions, i.e., from the sixth climatic zone and beyond, toward the Great Bear.¹ Falcons are not, as a rule, entered to the chase in that region, as they cannot survive the bitter cold and have a horror of snow. They are therefore not flown in that area except in summer. At that time crows are nesting in the plains and both the young crows, fresh from the nest, and the mother birds, who are beginning to moult, are weak in flight. This weakness is an added inducement to falcons to undertake the easy task of capturing them. After a falcon has once grown accustomed to catching crows it is difficult to break her of this bad habit. In warm countries (where crows are most frequently found in the open fields) the opposite is true. From the sixth climatic zone southward falcons are customarily flown all winter. Here the crows are stronger and falcons do not chase them with the same eagerness. In southern regions crows offer no obstacle to the flying of falcons in the spring and summer, inasmuch as during both these seasons they withdraw to the hills to nest. Wherever there are trees, if it is necessary to fly a falcon in the presence of crows, one may do so with impunity, because these birds are in the habit of taking refuge among

¹ *septentriones*, "constellation of the seven stars," Great Bear or *Ursa major*.

the trees, where it is not possible for a falcon to follow and capture them. Moreover, when a falcon is unsuccessful in such a chase she can easily return to the falconer, and this experience will also teach her not to chase a crow on similar occasions. When she fails to capture it, on her return to the falconer she should have a duck put up for her as quarry. This will encourage her to soar and wait on.

From the foregoing it will be evident that in the case of a falcon who, when flown at the brook, habitually deserts her master that she may chase birds that molest her, it is less dangerous to fly her in the neighborhood of the nesting places of enemy birds, because in those situations she is usually unable to follow them.

Should a falcon take a bird that the falconer does not wish her to catch, he must go at once and remove the quarry from her grasp, taking care not to take it from her so roughly that the falcon learns the trick of carrying² in order to prevent the quarry being taken from her. Having in this way removed the prey, the falconer must take the falcon on his fist and carry her back to the point whence she was slipped, and there let her fly again; and, if there are ducks present, he should serve her with them. If, however, the waterfowl have flown away, let her wait on for a short time and then call her down to the lure and feed her. Whenever she rakes away, after a bird that is not her proper quarry, this procedure must for a while be followed to teach her to remain with the falconer and not to chase birds that she ought not to capture.

CHAPTER XXVI

HOW TO PUT UP QUARRY FOR A FALCON WAITING ON

We have now finished our discussion of falcons that fly away and do not remain waiting on near the falconer. Let us now consider

² *asportare*.

those that wait on above him during hunting periods. After the falconer has sent the falcon up to wait on and she has attained her highest pitch, he must approach the quarry from the direction in which they are least likely to see him, and must go as close to them as possible without alarming them, before the proper moment, either by his presence, the noise of his horse, or any other cause. Should the falcon start to fly away when he is already so near the prey that he is afraid to give a shout (to recall her) for fear of making the quarry rise, he must retire far enough to be able to call out without running this risk. Then let him call and signal the falcon by waving his glove frequently, by its tip. In this way she will recognize him as the man who is going to put up the ducks. When she has turned back and comes near him, he should approach the water birds and put them up.

If the ruse with the glove is sufficient to cause the falcon to lower her pitch, the falconer should at once hide his gauntlet and allow her to mount again to a higher level. He must not flush the quarry until he sees that she has regained the (approximate) pitch at which she is accustomed to wait on, nor until she is directly above her prey. Then he ought at once to put up the birds, for if he delays in performing this act some untoward accident may happen to the falcon as she waits on.

The falconer may flush ducks and other waterfowl in various ways: by his mere approach; by means of a drum; or by the noise of a glove striking against the shoulder or neck of his horse. There are many who use only drumbeats—a method that has both advantages and disadvantages. Novices and other falcons that are just being entered to flights at the brook may well have ducks served to them by beating a drum, chiefly because a tyro waiting on over ducks does not understand all the reasons for her acts and cannot be expected to remain long over quarry. Therefore when a falconer is not near enough

to put up ducks before she has passed overhead and is already moving away from the neighborhood of the waterfowl, the mere approach of a falconer is not sufficient to flush the quarry. The sound of a drum will, in that case, be more likely to make the ducks rise quickly for the falcon waiting on above them and before she is able to go far.¹ Hence the convenience of the drum, especially for young falcons. The air is set in motion by beating the drum and when the waves of sound strike the water the surface reflects them upward. The noise, seeming to come from beneath the ducks, alarms and disperses them as they rise; and so astonished are they in their ascent that they cannot easily escape without one of their number being either caught outright by the falcon, wounded, or forced down. This, then,² is the proper use of a drum in putting up ducks. Cases where the *timpanus* (or drum-head) should not be used will be discussed in the proper place.

As mentioned, the falconer³ can put up⁴ quarry by striking his glove against the horse's neck. If he sees, however, that the falcon's attention is easily attracted by the motion of the glove (making her think it is something to be thrown out for her) so that she does not notice the ducks as they rise or, seeing them, does not stoop over them, then the falconer may put up the quarry only by riding toward them. If he does decide to flush the quarry by his mere approach and not by beating the drum or by the use of a gauntlet, he must not call out as he rides toward the unsuspecting prey. It must be remembered that a novice may be attracted by a shout and led to believe that the lure is to be thrown to her in the way to which she is accustomed, and so does not

¹ *p'quam* (*postquam*) should be read *p'quam*, i.e., *priusquam*.

² The Bologna MS. (fol. 138^r, col. 2) gives *pacetur*; the Valencia Codex (fol. 229), however, reads *patet*.

³ *falco* should be *falco*' (*falconarius*).

⁴ The word *levare* has been omitted from the Bologna and other manuscripts.

notice when ducks are flushed for her; or if she does see them, she may not descend to attack them.

CHAPTER XXVII

ON THE VARIOUS FASHIONS IN WHICH PEREGRINES STOOP AT DUCKS OVER WATER; ON CAPTURE OF THEIR QUARRY, AND ON THEIR PROPER REWARD

After waterfowl have been made to rise by either the approach of the falconer, the sound of his drum, or some other means, the falconer must watch and see whether or not the falcon assails them. If she stoops rapidly over ducks that have been put up and have flown quickly away from the water (a small pond), we can be certain that she is partial to ducks; but we still do not know whether or not she fears water. But if the falcon stoops hard over ducks when they rise from a large body of water and fly across it (and while they are still above the water), we can be sure not only that she is partial to waterfowl but that she is not afraid of pools or streams of water. But she may descend slowly and follow the ducks in a listless manner while they are over the water and swiftly after they have left it behind; or she may fly slowly both while they are over the water and after they have flown beyond it. When she flies slowly at first and then swiftly, we may assume that the falcon is one who fears the water but is fond of ducks. If she proceeds slowly both before and after the ducks have crossed the water, we can be assured that she has no liking for ducks, but we remain in doubt as to whether or not she fears the water. This doubt will be further discussed later on.

Let us now turn back to the stooping falcon. She will, in the attack on her quarry, either capture a duck or she will fail in the attempt. If she succeeds, she will capture it

either over water or beyond its margin. If over water it will be either over the aqueous area from which the duck has risen or over some other that is either close at hand or at a distance. If the capture occurs over the water from which the quarry has risen, the prey may be seized either before it has flown beyond the margins of the pond or after it has flown off and then returned. Ducks that return to the watery resort from which they were put up do so because of their fear of the falcon's descent upon them, or because they have no confidence either in their powers of flight to save themselves or in being able to reach another water course near by which they hope will be an effective sanctuary free of danger from the pursuing enemy; but the most impelling reason for their return to the pond from which they have risen is that it is their habitual asylum, their place of refuge and defense. Those ducks that do not return to the same body of water from which they were put up fail to do so because its small area offers them little hope of protection or because they were driven off so forcefully that they are afraid to come back on account of the presence of the man who flushed them. They therefore choose flight as a means of escape.

When the falcon seizes her prey either over the water from which it was put up or above another body of water near by (or one at a distance), she must capture it either while it is still over the surface of the water (in which case the force of her stoop may carry her with it onto the water) or after it has come to rest on the pond; and, in this case, the quarry may drag her down into the water. Or, finally, the falcon may even capture the duck after it has dived below the surface of the pond in its fear of the falcon.

After a falcon has seized a duck and the impetus of her drive has forced them both into the water, the falconer must dismount and feed the former in the manner described in the paragraph on falcons that capture ducks

away from the water. This he must do because the falcon seized the duck over water and did not enter the pond through any fault of her own but was carried into it by the weight of her quarry. In the second instance (when the duck has pulled the falcon into the water), give her the heart of the prey and treat her in the same manner as the falcon that captured a duck away from water. This must be done because she did not enter the water voluntarily to capture the duck but was dragged into it by her quarry. In the third case (where a falcon seizes a duck that has already taken refuge in the water through its fear of her), it is evident that she has a great liking for duck and no fear of water. When this happens the falconer must not feed her but, coming to the rescue, must dismount and carry the duck, along with the falcon, out of the water and then remove the quarry from the falcon's grasp. If she has been broken to the hood, her headgear must be adjusted; or, if she does not wear a hood, he must, as soon as he has taken her up, ride away from the water. As soon as the falcon is dry, let him call her to the lure and feed her.

CHAPTER XXVIII

ON FALCONS THAT CAPTURE DUCKS AWAY FROM THE WATER; AND ON THEIR TREATMENT

If a falcon captures a duck away from the water, it may occur either at some distance [or close by].¹ If near at hand, the falconer on horseback must quickly come to the rescue; for although ducks are weak and easily handled, some other animal—an eagle, or a dog—may arrive on the scene. If the horseman delays his assistance, one of the interfering animals may either injure the falcon or force her to release her quarry; or else the

¹ *aut capiet longe ab aquam*; the words *aut prope* have been omitted, for the text continues with *si prope*, etc. The wording is the same in all the manuscripts.

captured duck itself (in the grasp of the falcon) may drag her back to the water. When the falconer sees that this is likely to happen, he must stand between the waterfowl and the water, to cut off its escape. In approaching the falcon, the falconer must not ride straight at her, lest this kind of approach frighten her. He should advance quietly and from the side, then dismount and continue on foot, just as is done when the falcon stands on the lure at the beginning of her training. Since a duck defends itself by beating the foe with its wings, and may tire out the falcon, the master must, as soon as he reaches the site of the contest, take in his hand the wings of the duck, twist them together over its back, and allow the falcon to strangle it. Then, while she is still holding the quarry, the falconer must insert two fingers (the index and middle fingers) into the lower portion of the breast near the abdomen² (breaking the skin) and should thrust the fingers upward into the breast. The organ whose motion he feels is the heart. Taking it between his fingers, let him remove it and give it to the falcon.

If the falcon is one that is very fond of duck, as the falconer can discover by observing her manner of stooping over her prey, he must limit both the time she remains on the duck and her reward for proper performance of her duty. The falcon already has a preference for this waterfowl, and if she is allowed to stand over it too long and is otherwise recompensed her enjoyment will be so great as to cause considerable inconvenience. She may, for instance, lose her taste for the lure; also, she will learn, when stooping at duck, to dive in after and capture the quarry if it takes to the water or to settle near by at the water's edge. Again, she may not execute a good throw-up after her stoop but come down to seize the prey on the water as soon as she spies it.

An excessive fondness for duck may also

² *ovaria*.

have other results. When the escaping duck does not take refuge in the water (dragging the falcon with her) but flies far away from the pond and the falcon in stooping fails to capture it, she may follow her quarry for a great distance and be lost; or some other accident may befall her.

If the falcon has little liking for ducks (as shown by her manner of stooping over them), she should be allowed to remain longer than usual on her quarry, so as to receive a greater reward, that she may develop a proper taste for this sort of quarry. In other words, the falconer must adjust the *douceur* to the falcon's behavior.

After he has fed the falcon the duck's heart, the falconer must cover the quarry so that she will not see it and, while holding the jesses firmly, gently remove the duck without injuring the falcon's talons and lift her on to his fist. Now let him throw out before her the lure with meat attached, and when she has flown to it, allow her to feed (while she is standing upon it) on any food he wishes her to have. This is done lest her liking for duck alone should overshadow her desire for the lure.

If the falcon, in pursuit of a duck, captures it at a distance from him, the falconer must ride swiftly after her. If she is one that can be hooded he must not feed her; if she is not broken to the hood she must be taken on the hand and placated by means of a tiring until the falconer is again on horseback. Then, when he is riding away, he should remove the tiring from her grasp and should advance toward the place from which she was first flown. When the falconer has reached a point about the distance from it that she is accustomed to fly to the lure, his companion (if he has remained with the lure at the place by the water from which the falcon was flown) must call her to the lure. If both men have followed the falcon, they must both return to the place from which the hunter was flown

and, when near it, one of them must go ahead to that spot and, when the bearer of the falcon is near enough, let his companion call her to the lure and feed her as described above. Even though there are ducks still present, it might easily be productive of further ills to permit her to fly at them a second time, especially if she is fatigued or is a novice. Indeed, it is generally better to lure and feed her at the station mentioned than to make her fly again on that occasion. She should be fed there (on the lure) rather than where she captured the duck, because if that were done she might follow her quarry a long distance on another occasion and so go astray.

CHAPTER XXIX

ON FALCONS THAT FAIL IN THE STOOP TO CAPTURE A DUCK, AND ON THEIR SUBSEQUENT BEHAVIOR AND TREATMENT

If the falcon does not capture her prey in her stoop, the latter may be driven either into the pond from which it rose, or into some other near by (or not far distant) body of water, and as a result the falcon will pursue one of the following four modes of behavior: Either she will drive the quarry into the water, then rise and wait on until the falconer again puts it up for her. Or she will force the prey into the water and then mount again into the air while the waterfowl dives and, as soon as she sees it emerge and start to swim about, she will stoop to strike again; then, while the duck dives (for safety), she will once more wait on, and repeat this maneuver until she is tired out and goes off to perch near by. Or the falcon may force the duck to land on water and go at once to perch on the shore. Finally, she may drive her quarry into the water and drop down with it, expecting to make a complete capture of the prey.

When the falcon is of the first type, the falconer must put up the waterfowl in the

manner already indicated. If the duck will not leave the water because it is afraid of the falcon, and if the surface of the water is so great that one man cannot alone accomplish the task of driving off the quarry, the falconer's companion must ride to the opposite shore, and then both men, by striking with their gloves on the necks or shoulders of their horses, can force the ducks to rise and leave the water. Every effort should be made to succeed in this plan, lest the falcon become fatigued from frequent stooping and lose hope of being able to capture a duck that rises only a little from the pond. In consequence of such a disappointment she is likely to seek a perch, to rake away, or to develop some other bad habit. If, however, in her stoop she does seize and hold a duck (either near to or far from the falconer), she must be treated in the manner appropriate to this behavior.

If the falconer is convinced from her performances that the falcon is of the second type, he must himself withdraw to a point from which she will be unable to see the ducks and, having called her off with the lure and recovered her, he must send her up again, letting her ring up until she will go no higher. He should then return to his first position and put up the quarry. If she repeats her first performance, he must not do just as before, but as soon as he sees what is happening he must put up the prey with greater vigor and force it to fly away from the water, so that the falcon will learn to capture her quarry at a distance from the pond or stream and thus forget her bad habit of always stooping at them while they are on the water. If she now captures a duck, she must not be rewarded while standing on it, nor allowed to remain there for long, but the quarry must be removed as quickly and gently as possible from her grasp, or, at the most, she may be given the heart. She is not rewarded further because she has already a sufficient liking for duck.



PLATE 131.—Emilio Caggiano's statue representing Frederick II of Hohenstaufen,
on the façade of the Royal Palace in Naples.



PLATE 132.—Abbey of the Holy Trinity at Venosa (the birthplace of Horace). Eleventh century. Built with material from a Roman amphitheater. Here are buried four sons of the Norman Tancred d'Hauteville.

If a falcon flies off to perch on the shore directly after her first stoop over ducks, the falconer must move some distance away, then summon her with the call he uses for that purpose and wave his glove. If she does not rise when he has done this a number of times, let him give the cry he employs when luring her and further induce her to rise by swinging the lure. As soon as she is on the wing and coming toward him, he should conceal the lure and change his cry to that used while recalling her when waving the glove alone. When she is finally waiting on at her usual pitch, the waterfowl must be put up with considerable force. This procedure will break her of the habit of perching on a bank or on the shore.

When a falcon in her first stoop dashes into the water, the falconer should allow her to remain there until she is tired out and finally comes out of her own accord. When she has at last left her aqueous bath, he must go a little way off and wait until she has shaken some of the moisture from her wet feathers and then call her, giving the cry he uses when she is waiting on, and waving his glove. If this effort does not make her rise, he must show her the lure and thus induce her to take to the air. When she responds with alacrity to either summons he should allow her to ring up and wait on. If there are ducks still on the water, they must be put up vigorously so that the falcon will overtake them only when beyond the surface (of the pond); she will thus perceive that it is easier to capture them there. This experience will encourage her to give up the habit of dropping into the water. Since her eager attack is indicative of her partiality for duck, give her the heart of the duck she has captured, gently remove the duck itself from her grasp, throw out the lure, and feed her. If all the ducks have left the pond after the falcon has gone up to wait on, call her to the lure near the water and there feed her.

If a falcon brings down a duck at a distance from the falconer, the latter should take it

from her as quickly as possible, hood her (if she has been broken to the hood), and carry her back to his assistant, who must call her to the lure. If ducks are still at hand and the falcon is able to chase them, let her do so after they have been put up.

When the falcon captures a waterfowl far from the falconer and he finds that she has already fed upon it, she will have consumed either much or little of its flesh. In either case she must not be fed again that day. If, however, she has eaten very little of her prey, then, on the next and following days she must be called to the lure as usual and thereafter flown at waterfowl. If it is found that the falcon has made a full meal of the captured duck, her ordinary ration must be reduced for several subsequent days. Feed her upon washed meat and adjust its quantity to her condition, bearing in mind the amount of food she consumed. If she is heavy and has taken quite a large meal, her food can be greatly reduced; but if she is thin she must be less severely dealt with. After her weight has been properly lowered, she should be exercised with the lure for several days, and then flown.

When the falcon has failed to capture the quarry, she behaves, as a rule, in one of the four fashions we have just described. When she is discovered by the falconer waiting on over a [distant] place where she has just put in ducks, he must not flush them but must call the falcon (by waving his gauntlet) and try to lead her back to the spot where he left his associate. If the falconer finds that she has already left the place where she put in the ducks, he must gauge the distance between the falcon and his companion, and, if he notices that she is greatly fatigued or that the distance seems so great that he cannot hope to bring her back, he must guide her as far as he can away from the pond where she put in the waterfowl and then call her to the lure. But if the falconer thinks she can be guided all the

way to his companion [let him do so],¹ when the latter can proceed as before.

In case the falconer finds the falcon stooping in vain over water and then remounting, he must call to her and wave his glove until he has led her away. When he has succeeded in this maneuver, let him try to guide her back to his assistant. If his efforts to induce her to follow him are unsuccessful, let him adopt other methods of recovery.

When the falconer finds the hunting falcon perched on a bank, he must make her rise by shouting or by showing her the lure. Then let him entice her away from the ducks and do his best to pilot her to his companion, using whatever additional means he finds necessary.

If he finds that the falcon has flown into the water after the quarry, let him wait until she comes out of her own accord and then lead her back to his assistant, using the various devices we have suggested for that purpose.

The rules the falconer should observe in the case of a falcon that has followed a duck to a distant locality (i.e., those against putting up the duck at the point where she sent it to cover and against calling her to the lure at that point but enjoining the practice of leading her away and back to the falconer's companion) are all repeated to emphasize the rules for the education of the falcon—e.g., how she is to follow the falconer, and not to wait for him to come to her and flush the quarry that she has chased and put in far from her master.

If the falcon has abandoned her pursuit of the water birds (because she is exhausted), and then returns and comes down to the lure before the falconer perceives what she is doing, he must at once hide the lure. When he has done this and she has risen to wait on, the falconer must move toward his companion and they must both perform the tasks allotted them, as in other cases of returning falcons. If and when the falcon is so keen for the lure

¹ Words missing in the manuscript.

that she is unwilling to rise (and wait on) and the distance to the falconer's assistant is great, or the falcon is fatigued, then the falconer must throw out the lure, recover the falcon, and carry her back to the point whence she was flown. Here she must be treated in the manner we have already indicated. When the falconer sees her coming back, let him show her the lure² and move toward his companion.

When the falcon follows ducks and then checks at other birds and chases them, the falconer must watch to see whether or not she actually captures one. If she does, either in plain view or out of the falconer's sight, he must, just as soon as he observes what is happening, ride after her as fast as possible. Let him remove the captured prey from the falcon's talons and carry her back to his companion and there serve her with ducks if there are any available. If not, she must be called to the lure.

CHAPTER XXX

ON THE DANGER OF FLYING A FALCON IN THE PRESENCE OF AN AVIAN SPECIES AT WHICH SHE HAS PREVIOUSLY CHECKED AND ON WHICH SHE HAS MADE A MEAL

When the falconer has discovered what bird the falcon has fed upon, he must thereafter be careful not to fly her in a region inhabited by birds of that species.³

If he did not see the falcon when she first seized her quarry, he must at once determine whether she fed upon it or not. If she made no meal, let him carry her back to the place whence she was flown and let her fly again. If, however, she has eaten of her prey ever so little, she must be starved on the two following days. Not even on the third day is

² *ascendet loyrum* has been emended to *ostendet loyrum*. Bologna MS., fol. 140^v, col. 2.

³ This short paragraph is apparently a summary of the long review that follows it.

she to be given much food, but she must meanwhile be called to the lure. If she has partaken of a full gorge, then reduce her rations for several days, feeding her on washed meat in amounts proportioned to what she consumed, and taking into account her habitual rations and her lean or fat state.

When the falconer does not recognize the avian species the falcon consumed (perhaps because he was unable to find the place where she made her meal), the next morning he must inspect her castings. Let him carefully examine them, to decide to what species the feathers (contained therein) belong. When the falcon is flown again, the falconer must take care to avoid that species of bird.

When a falcon checks at other birds for which she abandons her legitimate quarry, she must be recalled by means of appropriate cries. If she fails to respond and continues her pursuit of the inferior prey, the falconer must ride, as best he can, swinging his lure, after the falcon that is raking away. If he can by any means get in front of the errant falcon, let him throw out the lure, so that she will see that decoy and be induced to abandon her chase of the bird² and come to it. She must not be fed now but be given some small bits from the meat on the lure. Such a falcon is not to be full-fed, because she did not at once abandon her improper hunt at the sound of the falconer's voice. If she were fed after checking at a bird, she would gladly repeat the offense upon a second occasion, in the hope of being again rewarded with food.

If, however, she does abandon her pursuit upon hearing the falconer's call, she must be brought to the assistant and handled in the manner indicated in our former instructions. If the distance is so great that the falconer does not believe he can guide her all the way, then let him throw her the lure and feed her.

As a rule, all birds that may be the cause

² The text (Bologna MS., fol. 141, col. 1) says *anates*, an obvious scribal error.

of interference in hunting at the brook are to be strictly avoided, especially crows, *frii*,³ and similar species. The falcon's preferences must also be taken into account, for some hunters are attracted by one bird and some by another. Special care must be taken, therefore, not to fly a falcon at the brook where there are usually found the birds for which she has an especial preference.

When a falcon gives up the pursuit of a duck because there appear on the scene eagles (or similar foes), or because other birds mob her, her fear sometimes causes her to ring up and her continuing terror prevents her descent to the lure when called. Frequently, under these conditions, she is lost. The falconer will recognize by the following signs that her acts are the result of this fear: She shakes her tail and sometimes her whole body, then circles about with her caudal extremity widespread. Sometimes she moves her wings, or she may hold them quiet. When a falcon behaves in this manner, the falconer must call her to the lure, and as soon as she arrives he must feed her while she stands upon the decoy. She must be fed there at once, because fear of her avian enemies has made her cautious about coming to the lure and this alarm often leads to the loss of the falcon. She must be given food, to overcome her panic, so that on another occasion she will come when called.

CHAPTER XXXI

ON FALCONS THAT HAVE NO TASTE FOR DUCKS; AND ON THE FALCONER WHO HAS MISTAKEN SOME OTHER OBJECT FOR A DUCK

When a falcon has been flown and the falconer has put up ducks as quarry but she refuses to stoop at them, either while they are

³ Bologna MS. (fol. 141, col. 2) and the Mazarine MS. both say *frii*. The Valencia text omits the expression altogether. An English equivalent is unknown to the translators.

over the water or after they have retreated beyond its margin, this may be taken as a sign that she has no taste for ducks. Such hunters are usually noble falcons, hatched on cliffs far from the sea and other large bodies of water (or in warm climates where there are no ducks in summertime), with the result that they have been fed upon other birds, i.e., those found in the fields. Not having had any experience of waterfowl (as food), they have no liking for them.

As a rule, eyases of all species of falcons are unwilling to stoop when first entered to water birds. To determine whether or not this disinclination arises from fear of water, take a live wild duck that can fly but that has been entirely seeled. Send up the falcon to wait on over a field where there is no water, and when she is directly above the falconer's head toss out the duck against any wind that happens to be blowing. If the duck were thrown out with the wind it would be unable to control its flight and would fall to earth. A falcon comes readily to such quarry, for in its blindness its flight is weak. When she has caught the duck she should be fed while standing on it, and the falconer must make every possible effort to propitiate the falcon as he feeds her. The following day he should set loose a somewhat stronger duck for her and, if she comes down willingly, on the third day let him try her with a still stronger wild duck, that is not seeled. To do this effectually let someone hide in a blind, where the falcon cannot see him, and hold the duck until the falcon is waiting on. When all is ready, the falconer, who has sent up the falcon, must run toward the blind shouting as if to put up quarry, and the man hiding there must loose the duck as soon as he sees the falcon coming.

If the falcon stoops eagerly over the duck and captures it, let her feed on it. The following day give her a smaller meal than usual, and on the third day let her fly at ducks that are put up to her from water that

is not in any way sheltered. This is done so that the falcon may see plainly the ducks on the water. If she comes willingly, let the falconer note whether she stoops while the ducks are still on or over the surface of the pond or stream or after they have flown beyond its banks. If she comes down boldly and eagerly to the ducks over the water, one can be sure that it was not fear of the water itself that prevented her from attacking the waterfowl, but most likely it was her unfamiliarity with the quarry; but if she fails to stoop boldly over the water and descends on the ducks only after they have flown away from the water, it is a sign that it was fear of water that prevented her stooping.

It sometimes happens to a falconer who is on the lookout for water birds at the brook or on ponds that he hesitates to go very near them lest they rise before he is ready for them. Under these circumstances he may catch sight of some object that he thinks is a duck, but he is not sure because he cannot see it clearly. Under this mistaken impression he, or someone else who is also looking for waterfowl, may fly a falcon at the assumed duck but, on getting closer, discovers he has made a mistake. In such a situation the falconer must not throw out the lure immediately to the circling falcon. He must allow her to ring up to her customary pitch, especially if his hunter is one that does not tire of waiting on for some time and can endure a long period aloft without flying away from the falconer for one of the causes we have discussed. Were the lure thrown out before the falcon had reached her full pitch (and if this were to happen a number of times), she would soon learn not to ring up to her proper level every time she is flown, hoping and expecting that the lure (with meat) will be thrown to her. In the interval, therefore, during which the falcon is mounting and before the lure is tossed to her, the falconer must ride back and forth along the bank, striking the horse's neck

with his glove and calling out in the manner proper when a falcon is waiting on. This procedure will prevent her acquiring the bad habit of expecting on all occasions the throwing out of the lure. It may even happen that, as he rides along the bank, the falconer will put up ducks of whose presence he was unaware. If he does not, he may then call the falcon to the lure. Should she be a novice that he is afraid will tire if flown a second time, she must be fed with or allowed to take morsels from the meat intended for the lure and not flown again at once, but be permitted to rest and then to chase her prey a second time.

The falconer must be careful never to fly a falcon at the brook unless he is sure there are ducks on it, and until he has first observed clearly and exactly where they are. This precaution will assist him to decide when, in what manner, and in which direction he should flush the fowl.

If the falcon that has been flown at what was erroneously thought to be a duck is a hunter that tires easily of waiting on, or that does not wait on long without flying away from her master (for one or more of the other reasons we have discussed), the falconer must not delay in luring her or waste his time riding along the bank, but at once throw out the lure and feed the falcon. If he delays in calling her to the lure, she will very probably fly far away.

CHAPTER XXXII

ON DUCKS THAT RISE OF THEIR OWN ACCORD

After the falconer has slipped the falcon at the brook where there are ducks it sometimes happens that the quarry rise of their own accord without any human intervention. This occurs frequently with ducks that have often encountered men hunting with their

falcons. Such waterfowl rise easily because they either see the falconer or hear the sound of the falcon's bells, the voice of the falconer, or the noises made by the horses. Under these circumstances they rise chiefly because the water is shallow, and they know there is no safety in diving.

When ducks rise of their own accord, the falcon may or may not pursue them. If she does not chase them, it is because her attention is fixed either upon the falconer or on some other object so that she does not see the ducks, because she has seldom or never before hunted waterfowl, or because she is inspired by fear of the particular locality (it may be one of those that falcons habitually shun); or, again, she may have no desire to hunt ducks that rise of their own accord because she expects that her prey will be put up for her in the manner to which she has grown accustomed. Perhaps she believes that it is easier to take quarry put up in that way. Falcons with whom the falconer has taken many ducks are even more inclined to refuse to fly at waterfowl that rise spontaneously when they have been intermewed than when they are still unmoulted. This is a correct observation in the case also of falcons that are sluggish and doubtful of their ability to keep up the chase until they actually capture a duck. When a falcon does not follow ducks that have risen of their own accord, she must be treated in the same manner as falcons that are flown where there are supposed to be ducks and there are none.¹

When a falcon does pursue fowl that rise of their own accord, a falconer should follow her, shouting and performing other acts necessary to bring her back. On her return he should watch the manner of her flying and treat her in the same way as a falcon flown to ducks put up by human agency. If she fails to return, the falconer must ride after her as quickly as possible and then follow the in-

¹ See Book VI, chapter xxxi, p. 409.

structions laid down in a previous section. When she abandons the chase after ducks and returns to the falconer of her own accord, if he knows that some of the ducks have remained on the water through fear of the falcon or settled in it when the falcon stooped, he must proceed as follows: The returning falcon will fly either high or low. If she comes back at a low altitude, she must be encouraged to ring up to her normal pitch or at least to a height suitable for serving her with quarry. The falconer must then put up the waterfowl for her. If she makes a capture in any of the ways we have described, the falconer must take note of the situation and treat her according to instructions already given.

When ducks are put up a second time and the falcon fails to seize them, the falconer must call out to her and, when she comes back from the chase (at a high or low pitch), she must be allowed to ring up as before. If no ducks remain on the water, she must be shown the lure and fed upon it in the usual manner. When she returns (at a high pitch), the falconer must wait until she is directly above him and, if there are no ducks on the water, toss her the lure and feed her while she is standing on it.

When ducks have been put up to a falcon a number of times and it is seen that she is exhausted after the second or third flight and there is danger of her flying away to perch because of that fatigue, she must be called to the lure even though there are waterfowl at hand. These birds must not be put up to her, because it is better to recover her by means of the lure than to permit her to go to roost through weariness. The use of the decoy must be practiced as often as the falcon behaves in the fashion described.

Furthermore, when ducks have been put up to a falcon who fails (in her stoop) to take her prey, and who does not come back to the falconer when called but flies away, one falconer must remain near the water at

the point from which the falcon was slipped, while the other rides as fast as he can after her. The latter must give the cry used to call her back and whirl his glove in the usual style. He will soon see whether she is coming toward him or not. If she continues to rake away, he must continue his pursuit, calling out, waving his glove, and employing other signals as before. If she starts back in his direction, he must continue his efforts to recall and steer her toward his companion. In every instance the falconer should take into consideration the altitude the falcon has chosen, i.e., whether she is flying at a low or a high pitch.

When a falcon returns of her own accord, no matter what her manner of flight, she must be treated just the same as if she had returned at the falconer's summons.

CHAPTER XXXIII

ON FALCONS THAT FAIL TO CAPTURE QUARRY RETURNING TO ITS WATERY REFUGE¹

When a falcon is one that fails to capture her quarry while it is returning to its water resort her behavior in this instance will fall into one of four categories: (1) After she has stooped over the water she will ring up and wait on until the falconer puts up the prey a second time. (2) In her descent she will force the duck to the water and when it dives, in fear of her, she will ring up and, as soon as she sees it emerge and start swimming on the surface, she will again stoop. If it dives

¹ Much of the matter treated in these sections of Book VI consists of slightly modified or amplified repetitions and applications of subjects previously discussed. As pointed out in the Foreword of this translation, this method of presentation is not, in the medieval view, a literary defect, nor does it introduce examples of questionable diction. On the contrary, the imperial author adopted it as a well-recognized and successful effort to implant in the reader's mind important truths bearing on the none-too-simple task of teaching the ignoramus all about falconry, not only in its theoretical but also in its practical aspects.

again she will repeat the maneuver until she grows tired and goes to perch. (3) A third mode of behavior is for her to go to perch as soon as she sees the duck dive below the surface. (4) She may stoop and drive the duck into the water in the hope of catching it, and will even plunge in after it.

CHAPTER XXXIV

ON ENCOURAGING THE RETURN OF A FALCON THAT HAS RAKED AWAY¹

While a falconer is urging the return of a falcon, he should observe her manner of flight; for if she has had a long chase after ducks or has checked at other birds, she will come back greatly fatigued. This result the falconer will at once recognize by her slow, low flight. It is probable that the distance will be too great for him to be sure of leading her back to his assistant without running the risk of her going off to perch somewhere. He must then throw her the lure, while she is directly above him, take her up, and feed her in the manner described. Should the falconer see that she is little fatigued and if the distance to his companion is short, so that there is no danger of her going to roost before reaching him, the falconer must call out, using the cry employed when a falcon is waiting on. This is done as a warning to his companion that the falcon is on her way. He must also wave his glove, in the approved fashion, until his companion near the water is made aware, from his cry, that the falcon is coming toward him or until the assistant sees the falconer returning and hears him calling out even though he cannot see the falcon. The companion must then respond in the same manner, calling out and waving his gauntlet. As soon as the falconer who is guiding the falcon on her return hears his companion's cries, he must cease his own shouts and glove-waving and allow the falcon to answer the summons

of the associate standing by the water. The falconer must nevertheless ride as quickly as possible toward the latter, watching the returning falcon continually to see whether she goes directly toward the assistant, waits on directly above his own head, or rakes away in another direction.

If she goes straight toward the companion, the latter (when he sees her coming) must notice whether she is flying high or low and whether or not she is tired out. In case she is flying high (whether fatigued or not), as soon as she arrives immediately above the ducks the falconer's companion must put them up; and if she seizes quarry either over the water or beyond the margins of the pond, she must be treated according to the manner of the capture. If there are no ducks present, then the lure must be thrown out and the rest of our previous instructions carried out.

Should the falcon be flying low upon her return, the assistant must decide whether or not she is exhausted. If she seems so fatigued that he is afraid she will not be able to ring up and wait on, but will go to perch, then he must throw her the lure and feed her. For it is better to take her up with the aid of the lure when she is much fatigued and before she flies off to perch than to allow her to find her own resting place. If she does go to perch (either close at hand or at a distance) before she is lured, she must not be called off to the lure at once but be allowed to rest a while on her chosen roost. Then she may be called away with the help of glove-waving, etc., as when she was summoned while waiting on. When she has risen in response to a call and has circled about the falconer two or three times, he should throw her the lure and feed her.

If the falcon comes back flying low but is not tired, allow her to ring up, if she will, to the normal pitch at which waterfowl may be flushed for her. If it is seen that she is unwilling to ring up, then, before she is fatigued

¹ Cf. footnote, chapter xxxiii, p. 412.

by attempts to make her do so, put up such ducks as there are on the water; if there are none available, the falconer should throw the lure and give her a meal.

If the falcon is very tired when she comes back flying low, and has no desire to ring up, then she should be recovered with the lure.

When a falcon is brought back, if she refuses to go to the falconer's companion but insists on waiting on above the falconer himself, the latter must not call out, nor wave his glove, but ride close up to his companion so that the circling falcon will follow him and come over the associate now stationed near the water. When she hears the companion's voice and sees him whirling his glove above his head, she will go to him, after which he must treat her according to the instructions we have already given.

If the falconer who is trying to conduct the falcon back to her proper place sees that she is raking away in another direction, he must follow her until she turns back. When this happens he must carry out the usual plan of action.

When a falcon that has been sent aloft does not wait for any quarry to be put up but flies off after birds that she sees at a distance (or for any other reason), the assistant should remain near the waterfowl while the falconer follows his hunting bird to carry out the maneuvers suggested above.

If a falcon will not come in response to the shouting of either man (i.e., the assistant remaining near the water, or the falconer who is following her) but flies so far away that her master is unable to see her, the latter must take the lure and swing it as when calling her to the decoy, at the same time giving the appropriate lure cry. As he does all this he must search the neighboring ponds, pools, and streams frequented by ducks; for it is in such localities that falcons customarily hunt. This scheme should be carried out every time a falcon rakes away so far that the falconer loses

sight of her, but not otherwise. If the whirling of the lure does not bring back the wandering falcon, she may be expected to chase the ducks either until she drives one of them into some body of water in which it is accustomed to find refuge or until she abandons her pursuit through loss of interest in her quarry or checks at another bird.

It sometimes happens that before a falcon drives a duck to a pond she has flown so far from the falconer that he is unable to see her, and all attempts to recall her are in vain. Then her master must take his lure, swing it in the usual manner, and shout the appropriate calls. This is to be done only when the falconer is unable to see the lost bird. The assistant who has remained behind, near the water, will then recognize (from the nature of the falconer's cry) that he is unable to see the falcon and also that he is still luring the straying bird. When the companion realizes the condition of affairs, he should remain at his station near the water for whatever period he thinks sufficient for the falconer to recover his hunter. The falconer, after recovery of the wanderer, should return to the place where his companion is waiting and, if there are ducks on the water, they should be put up. This will help to teach the falcon to remain above the falconer who is flying her and, when she chases a duck, to return to him quickly and of her own accord. If there are no ducks on the water when she is brought back, the falcon must be made to wait on until called to the lure. If she refuses to wait on she must at once be lured and fed.

When a falconer in pursuit of a strayed falcon fails to bring her back, his companion, after allowing ample time to elapse, if he has a second falcon with him and there are ducks on the water, must fly his own falcon. In this manner the stray hunter will be recovered more quickly; for it is the habit of falcons to fly toward another of their kind whom they see in flight.

Explicit Liber Falconum cum Quibus Venantur



Deo Gratias Amen

[The seal is that of Emperor Frederick II of Hohenstaufen]



Appended Material

THE MEWS,¹ ITS FURNITURE AND ACCESSORIES

THE RESIDENCE, as one might term it, of the captive falcon is well described in Books I and II of the *De Arte Venandi*, especially in chapter xxxiii of Book II. Its form and management have altered very little during the past seven hundred years. Its chief utility has always been that of a refuge for hawks during their moulting season—a shelter where they could be properly cared for while undergoing the annual change (*muta*) of their plumage. Although commonly employed for that purpose, it was also used as a day-and-night roosting place for these captives, fledglings or adults, wild or trained, hooded or sighted, sick or well. As the Emperor says in the Prologue to Book II, one of the most important tasks of the falconer while educating his falcons is the provision of suitable quarters for taming them, so that they will not grow up in fear of man. In speaking (Book II, chapter xxxiii) about the rearing of young (*eyas*) goshawks, he suggests that an aviary be built of materials like those in their wild eyrie, which should be open to the northeast and the west breezes and exposed to both the morning and the evening sunshine. Toward the south it should be closed to prevent the hot winds from harming the birds by drying up the humors of the head (sunstroke) so that they become inactive and weak.

The perches on which hawks are to rest should be of several sizes, adapted to the wants of the denizens. Blocks were generally furnished for birds while weathering, but were not usually found in the mews, their

¹ This noun has the same form in both the singular and the plural.

place being taken by the low perch (*pertica ima*).

The bathtub and its garniture (*tinea balneatoria*) were almost invariably placed outdoors; bathing was a common supplement to the hack. The tub was uniformly of earthenware or wood—rarely of metal—placed on the ground, and neither too deep nor too shallow for the bathing bird. The leash employed was long enough for the captive to bathe or to drink at her ease.

The mews was large enough to allow the falcon (on occasions) a certain amount of free flying. It should have at least one window, and the ventilation should be sufficient but without drafts. There was a door in it large enough to permit easy entry and exit of the falconer with the bird on his fist.

The room should be kept scrupulously clean, and its floor ought to be covered with gravel or coarse sand and, if need be, sodded; these coverings must be changed as often as required.

Frederick (Prologue to Book II) directs that when hunters are mutting their flight and down feathers they ought to be kept by themselves in a small moulting-house (*domuncula quae dicitur muta*) that ought to be enclosed and sodded and to have its floor well sprinkled with sand. This chamber must be stocked with remedial agents, and these medicines should have vessels suitable both for containing and administering them.

The imperial writer promised a more detailed description of the mews in his projected work on "Hawks and Their Diseases"—a monograph he never wrote or which, if written, has been lost.

Among the instructions and descriptions furnished in the first two books of the *De Arte* we read that the most important roost in the mews was the high perch (*pertica alta*), to which the captive falcon was tied by a proper leash. As a precautionary measure, this perch has, in modern times, a curtain or screen (entirely unknown in the Middle Ages) by means of which the bating hawk is able to scramble back to her roosting place (instead of dangling dangerously in air). The low perch (*pertica ima*), not needing this precaution, is not so equipped.

Further details of these perches are discussed in chapter I of Book II, from which the following descriptions are taken:

The perch should be the only large article of furniture in the moulting or sleeping chamber; if there are more, the leashed bird will attempt to forsake her own perch and fly to one of the others. When there are two perches and birds are roosting on them in the mews, they should be separated by partitions or high screens. A perch should not be placed close to one side of the chamber, lest the restless falcon be tempted to climb up the wall near by; in any event her feet should be so tethered that she cannot reach the wall.

It is desirable to change the locality of the perch in the mews so that while she is still wild the captive may become more accustomed to new positions and strange noises. She should also be kept away from doors until she is tame enough to allow her some liberty and more light. Not only must the room in which she is confined be properly ventilated by the opening and closing of a window, but there should be no chance of fouling the air by the entry of smoke or other deleterious fumes.

The low perch, block, or stool may be made of either (preferably) wood round or squared (*lignea rotunda aut quadrata*) or stone, and it must be so constructed that when she is on her block, the feathers of the falcon's

tail do not touch the ground and thus become frayed or broken.

When made of stone, the broad, upper surface of the block is smooth—sometimes covered with soft cloth or leather. The whole structure somewhat resembles an inverted pyramid. Into the base of the block is inserted a sharp iron spike, the thickness of one's thumb. This peg, driven into the earth, makes a firm foundation for the stool. There is often placed on the ground, around the block but not attached to it, a wooden or metal ring for the attachment of the falcon's leash. Then when the leash is pulled or jerked in any direction by the bird, it runs round the ring, and does not impede the captive's movements when she is either off her perch or on it. The hoop (ring) is always carried about with the block.

Every block should be located (both indoors and out) well out of the route of passers-by, lest it be knocked about or the roosting bird disturbed. A plentiful supply of chaff, weeds, or sand should be spread around these low perches so that when the falcon springs off her roost to the ground she does not injure the ends of her tail feathers.

The Emperor discusses in lengthy detail the relative merits of the various high and low perches, particularly their uses with both blinded and sighted birds, when bating and at rest, also the methods of tethering them (for a variety of purposes) to all forms of the perch.

Of cades Frederick has nothing to say, for their use in outdoor transportation of falcons had not come into practice in his day. Travel was chiefly on horseback, and a staff of expert falconers was maintained to carry and care for the hunting birds while on a journey or when being transported to the fields.

The illustrations accompanying the present chapter show representative forms of the perch, medieval and modern.

me q' estrangetez durra. lui
de de ses arousemens est plu
sours. Car par les arouse

par a. L'ont en eice et que
il est eschaufez ait a rouise
mans puer estre fais plus



Que que li faucons a
ura estre auis longue
mant suer a la lumiere dou
iour cessera ia a li home
et les bestes en quencaront
ia a aler la et ia en plus
grant multitude li faucon
niers doit repaier a tout
le fauco des chans ala mai

ce que li faucons a
pas encore plainement pas
see meismement ce il estoit
des plus sauulges et par
ce a eues defier plusieurs
causes de lui delatre et q
mant quil soit auttendos
lui effraer a eues plus de
causes pour ce par plus
grant volence il se delat



PLATE 133.—(Above) Falconers spraying their birds to quiet them and prevent bating (Bibliothèque Nationale MS. Fr. 12400, fol. 157). (Below) Falconers carrying their birds about indoors and out. (fol. 155^r).

balneabit postquam iam comē
 derit, debet tamen dari sibi mi
 nus d' cibo q̄. aliis diebz, in
 quibz n̄ debz balneari. Si uo
 falco erit macer & timet q̄
 paucitas cibi addat sibi ad
 maciem postq̄ balneari erit
 & digesserit cibū prius sibi
 dari poterit sibi dari de cibo

dendi. & teneat capellum. Si
 man fuerit cū capello. longa sit
 aurez, tunc longitudo q̄ in
 tuare possit balneū falco & nō
 possit pertransire tinam. & postq̄
 potius fuerit falco ad sedendū
 si ē d' illis qui man fuerit cū
 capello. leuabitur capellū. & tene
 det ille qui leuabit capellum a

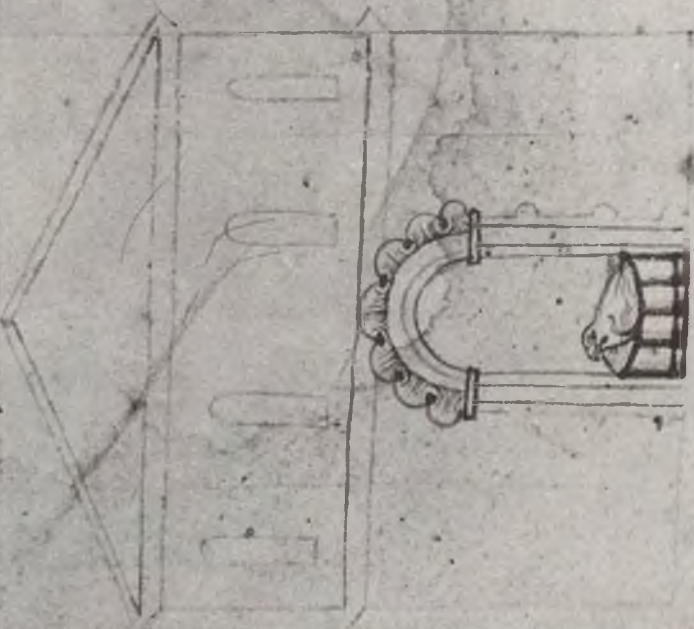

aut uocat uocis campana
 lam. Aut q. sentit de lignis
 et uellet solis uicla ut uola
 ter. et caetera. Aut q. ipm re
 ter campanelle pnt. et uoloz
 et alq. facit h. omnia c. f. amis
 Et si furo uolet se diuertare
 oppone foraminis seu fenestre
 ut dictum e. p. chusiam ipm
 remediatur eadem. Et dum fe
 nestram clausent falconarius
 se falconi opponit ut fenest
 ram n. uideat. pferens sibi co
 suos sonos quib. alienatur
 falco. ab intentione quam ha
 buit. ad fenestram di. uo. c.
 tuncis rei quam uidet. ac
 tendit falconarius que cau
 sa sit ante tuncis m. q. n.
 rem. et falconem statim falco
 narius se opponit ut eam vi
 dere n. possit. sonos alliaero
 eidem pferat. rem. et qua. et
 m. ut expelli faciat m. rem.
 et falco. et p. sonos sibi. pl.
 ros. et p. aspectum que. am
 sit rei p. ante ab illo quem ha
 buit pauore quietatur. Et si

i. u. u. co. q. om. non uolantur
 quare ipm sicut dicitur. iten.
 subleuet. et recipit sup. manu
 si uo. falco quietus manifeste
 sup. petram. nec de diuertare
 ne dimittat ipm quiete. usq.
 ad horam congruam. quia uo.
 dia. et recipiendus e. sup. manu
 Et qm. et p. d. diuertatib.
 et quietatib. possit falco. i. cur
 rare. tam. plone. p. alim. qm.
 p. n. arum. et obesse. et. am. m.
 sue. farum. falconari. sic. sup.
 dem. e. non. detet. a. falcone. tam.
 longe. uisitare. qui. sibi. ualeat.
 si. necesse. fuit. infra. scriptos. re
 medus. subuenire. Nam. di. fal
 conarius. uidet. q. falco. de. ue
 lit. in. aliq. d. p. p. d. d. d. d. d. d.
 uerare. consuetos. sonos. eadem.
 pferat. Et. si. p. r. r. r. r. r. r. r.
 sonos. quos. sibi. p. uic. quiete.
 ut. falconarius. remaneat. et. fal
 conem. p. m. t. quiete. dec.
 non. tm. q. p. r. r. r. r. r. r. r.
 et. m. a. quam. re. uent. sine.
 falconario. aliq. uic. u. r. r. r.
 tatis. acquirit. Et. si. fecit. p. r.



PLATE 135. — Illustration explaining the causes of bating—unusual sounds, light from a window, etc. (Vatican MS. Pal. Lat. 1071, fol. 92).



PLATE 136.—Illustrations demonstrating the behavior of falcons that are properly (*above*) and im-
 properly (*below*) carried (Vatican MS. Pal. Lat. 1071, fols. 102^v and 103).

DISEASES OF AND ACCIDENTS TO HAWKS, AND THEIR TREATMENT

THE Emperor Frederick II promised¹ a chapter (or book) on avian maladies and their care—subjects that have received much attention in most works on falconry, ancient and modern. If the Emperor ever fulfilled his promise, what he wrote has been lost. In the *De Arte Venandi*, however, he gives directions for preventive sanitation and how thereby to ward off trouble from hawks. He believed in avian hygiene and bodily care of his birds rather than in busybody and doubtful drug medication; and we suspect that his doubt as to the curative value of the latter was associated with his disbelief in the nostrums of medieval quacks. In this regard he showed both his usual perspicacity and his disregard of mere traditional procedures unfounded in reason.

The fact is that the pharmacal care of sick birds, as laid down by the old authorities, usually did more harm than good; when the patient got well she generally survived in spite of "treatment," not as a result of it. In the *De Arte Venandi* it will be noticed how seldom even the names of accipitrine diseases are found; and, although the following brief and incomplete account of avian pathology is descriptive of the chief diseases (*infirmities avium*) that affected the Emperor's collections of birds, the sources of that information are not in his writings. He often refers, however, to the signs of *health* in a hawk—when the eyes are brilliant and wide open, the breathing regular and easy, the expired air free of offensive odor, the excrement white

and of normal consistency, and the bird quiet on her perch. When these signs fail, there is something radically wrong.

In this connection the Emperor was particularly anxious that his hawks should be surrounded by conditions most favorable to a successful moult. He fully describes these desiderata, and warns his falconers to follow closely his directions therefor.

Although *moulting* cannot properly be termed a disease, yet it is a periodical return of a general condition which calls for special care and attention. The moult of eyas birds of the previous year, when they are normally protected, is from mid-March to early April. The moult begins later in older falcons.

The seventh feather of the wing is the first to fall, after which the secondaries are renewed one by one. Then the shoulder and breast begin to moult; finally, all the primaries and tail feathers are affected and, last of all, the first primary is shed.

Salvin and Brodrick devote considerable space to the treatment of hunting falcons during the moulting season and tell us that falconers vary in the care of their birds during that important and often prolonged period. Some owners continue their birds at work and treat them as usual, merely taking care that they are kept in such high condition as is consistent with good flying order, giving them at the same time some additional shelter during inclement weather.

This rule is found necessary during the best season for taking rooks and herons, for it corresponds with the first part of the moulting period. The objection to such a procedure

¹ See under "Manuscripts and Editions of the *De Arte Venandi*," pp. lxxxiv-lxxxvii, above.

is that hard, outdoor work prolongs the moulting process; also the growing, immature feathers are in danger of being injured or struck out.

A second plan is to keep the moulting hawks on their blocks and at rest, meantime feeding them well. In this way they assume perfect plumage, although, through long inactivity, they may lose a certain degree of wing power.

Another plan, advised by the older writers on the subject, is to give each falcon his or her freedom in a large and airy room the floor of which is well covered with fine gravel or sand that is regularly changed. Birds should also have a bath constantly filled with clean water, and they are to be well fed.

A fourth and quite successful plan is to house the birds singly (or several of the same sex together) in a warm, good-sized loft with a slate roof. This mews, along with bathing facilities, a sanded floor, and a single grated window, combines conditions favorable to the early regrowth of lost plumage and, allowing freedom of flight and exercise, does not retard or reduce their hunting powers when they are eventually flown in the field.

That the hawk's dietary under varying conditions of age, employment, season of the year, and other states of health and mind calls for expert knowledge is constantly dwelt upon by our imperial author. A perusal especially of the last three books of the *De Arte Venandi* impresses one with the Emperor's desire to instruct his readers in numerous important hygienic measures to be borne in mind by the expert falconer. Avian dietetics—as applied to falcons—is not easily learned and we cannot repeat them here. It must be remembered, *inter alia*, that, while it is necessary to feed hawks very highly during the moult, they must not be kept entirely on beef, as it is too stimulating and monotonous. Moreover, their intake of castings should vary. A good menu may well include live pigeons, rabbits, yolk of eggs, and cottage cheese. Va-

riety in the bill of fare may also be attained by alternating the usual diet by an occasional gorge, followed by a decided reduction for the following twenty-four hours. Also, the bird's eyes ought always to be brilliant, the breathing always easy and regular, the mutes white, and the breath sweet. Stunted growth and indigestion follow or accompany the intake of defective food and the drinking of impure water; falcons suffer from these causes of illness, whether wild or captive birds.

Although Sebright was probably the first modern writer fully to describe the curious pathological state known as "hunger traces," it was not unknown to Frederick. It is a defect in the plumage of hunting birds, observed in the growth of the feathers during their developmental stages, due to starvation or to an irregular system of feeding. Generally all the bird's quills suffer; but the morbid changes, evident in the expanded tail or wing, consist of a well-marked line crossing the web of every feather, not only to be seen but also to be felt as a projection or ridge. Sometimes it is plainly outlined, as if a razor had been lightly drawn across wing or tail. This defect may be the cause of subsequent breaking of the feather at the site of the "trace."

The operation of "imping" (*imponere*), by means of which a broken feather is restored to its former usefulness, is important. The shaft of an injured quill should never be pulled out. Although in that case a new feather often takes its place, the latter is a poor, weak, and deformed substitute for the last one.

In imping, the injured feather is cut obliquely with a razor near its center so as to fit exactly part of a previously chosen plume (collected by the falconer as part of his stock in hand) cut at the same angle. A small metal "imping needle," first dipped in brine, is now carefully adjusted within the shafts of the fragments until a firm union is made of the two, *in situ proprio*.

Exuberant growths of beak and talons in the adult hawk may be "coped" with a wire-cutter or razor and the cut surfaces smoothed by knife or file. Wild birds manage this difficulty by rubbing these members on rocks.

The following brief description of certain avian diseases and their treatment usually followed through the ages is, much of it, quoted from Salvin and Brodrick.²

Tetanus, "cramp." This is a series of painful paroxysms affecting young birds, most of the muscles of the body being involved. The wretched victim writhes in agony, generally emitting convulsive screams, and dying after several days of torture. If the unfortunate creature survives, the bones of the wings and legs frequently will be found to have been broken. As there is no successful remedy—relief or cure—of this malady, which likewise affects other animals, the proper procedure is to destroy the sufferer just as soon as the disease is diagnosed.

Tuberculosis, "consumption." Occasionally young hawks, peregrines in particular, are infected by this disease, generally brought on by cold and neglect. It exhibits much the same signs and symptoms as in the human subject. Drug treatment is worse than useless; but, if furnished early, the disease may be relieved or cured by good feeding, proper shelter, judicious warmth, and outdoor exercise.

Apoplexy. This cerebro-hemorrhagic alteration—akin to the disease in man—attacks chiefly merlins and sparrowhawks; rarely peregrines. Goshawks also suffer from it if they grow too fat. Salvin says that it proves fatal to nine-tenths of the merlins that are trained every season. Sanitary precautions may prevent it, while good management and proper feeding may postpone the usual fatal termination. Exposure to a hot sun, obesity, bating, or even the terror induced by dogs and other causes may bring it on. Merlins kept as much as possible at hack or in a large,

well-ventilated chamber are less liable to this disease than birds more closely confined indoors to the block.

Epilepsy. These serious attacks of "fits," to which all hawks are more or less subject, are not immediately fatal, as a bird may live for weeks after the initial convulsion. Strict attention to the rules of avian hygiene may even restore the bird to normal health.

Croaks, kecks, pin. This is a bronchial affection the usual name of which is derived from the peculiar noise made by the sufferer when flying, bating, or otherwise exerting herself. It is analogous to coughing in the lower animals. It is peculiar to the peregrine, attacking both passage hawks and nestlings. Salvin says that it "generally makes its appearance in the autumn and spring, during cold and wet weather. It is a common but not dangerous disease when treated on its first appearance." Combined with rest, warmth, and proper diet, certain remedies will be found helpful. Laxatives are indicated: either six or eight bruised peppercorns given with the castings, or a little powdered sugar candy rubbed into the hawk's meat. Two or three grains of rhubarb, or even water, given by immersing a few pieces of meat, will assist restoration to health.

Frounce, aphtha, thrush. Canker or sore of the mouth, throat, esophagus, and intestines is practically identical with a similar affection in young children. It is commonly attributed to exposure to cold and damp. The bird first exhibits difficulty in eating, the tongue is swollen, and the entire mouth has a whitish-brown coating.

This disease is quite amenable to early treatment; but, if neglected, intestinal involvement arises and becomes acute, incurable, and finally fatal. Salvin advises that while the patient is firmly held by an assistant the exposed mucous membrane be thoroughly scraped with a split quill or other instrument until the parts bleed. The raw surface is then

² *Falconry in the British Isles*, pp. 125 ff.

freely dressed (sprayed) with a little burnt alum mixed with citric acid or lemon juice, so that some of the mixture may pass down the throat. The hawk is now fed for some time on a light, nourishing diet. Little or no beef should be allowed; mice, rabbits, or birds may be substituted. The local applications should be repeated two or three times weekly. In bad cases a weak solution of silver nitrate may be employed instead of the acidulated alum mixture. Of course the patient should meantime be kept warm and the mews well ventilated.

The blain. This is a serious disease, characterized by watery vesicles forming within the second joint of the hawk's wing. It is said to be peculiar to passage hawks and is certainly a difficult ailment to cure. If of long standing it may produce a stiff joint and further implications of the wing bones. Salvin advises early incision of the swollen parts, as well as opening the vesicles and allowing the fluid contents to escape. At the same time the hawk is kept as quiet as possible.

Young birds are subject, especially during the first year of life, to a disease similar to the blain. This vesicular affection attacks the insertion of the primaries when they are nearing their full growth, causing them to break off, leaving the stumps *in situ*. If the hawk is in otherwise good condition and is able to make an average flight, she may be kept until after her next moult, when the injured feathers may grow again, especially if meanwhile the stumps have not been extracted.

Indurated cysts, corns, swollen feet. Hawks are subject to swellings on the feet and toes if perched on hard, unyielding, or improperly shaped blocks. The growths almost invariably take the form of hard masses. These are really cystic tumors, often associated with intumescence of the surrounding tissues. When small and along the toes, they readily yield to incision with a sharp knife and emptying them of their contents. If the ball and joint of the foot are involved, the cure is

more difficult. The best, logical treatment is preventive. When affected, keeping the bird during and after treatment on soft padded blocks is next in importance. The application of iodine to the swellings may also help. Salvin has rarely seen a wild hawk with corns.

External parasites, ectoparasites. Salvin describes three varieties of these pests. The first is a flying tick, confined to young merlins. These parasites, whose original habitat is the surrounding earth and leafage, leave their hosts a few weeks after the birds desert the nest and begin to bathe. Hence it is probable that the insects attach themselves to these small hawks in search only of shelter and warmth, both of which are best found in eyases.

Another and more formidable parasitic insect is a species of acarus that burrows into the mucous membrane of the nasal passages and attacks also the eyelids. Increasing rapidly in numbers, they may invade the whole body. Merlins are more subject to the inroads of this pest than other hawks. If the early invasion is not soon checked, the insects may attack every bird in the neighborhood. Salvin advises that "at the first appearance of any soreness about the nares or eyelids of a hawk the parts be well washed out with a fine camel's-hair pencil dipped in a decoction of tobacco [to be afterwards described] followed by the application of a small amount of the red precipitate of mercury." The little brush used for the applications and the suspected parts should be closely examined, and as long as any red mites are visible on either this treatment should be given daily. Of course an infected bird should be quarantined to prevent spread of the disease.

A third, quite common, parasitic ailment is infection by lice. They are most often discovered in hobbies and passage falcons, but all species of hawks are subject to their depredations. Not infrequently hunting birds acquire these disgusting insects from their prey. How-

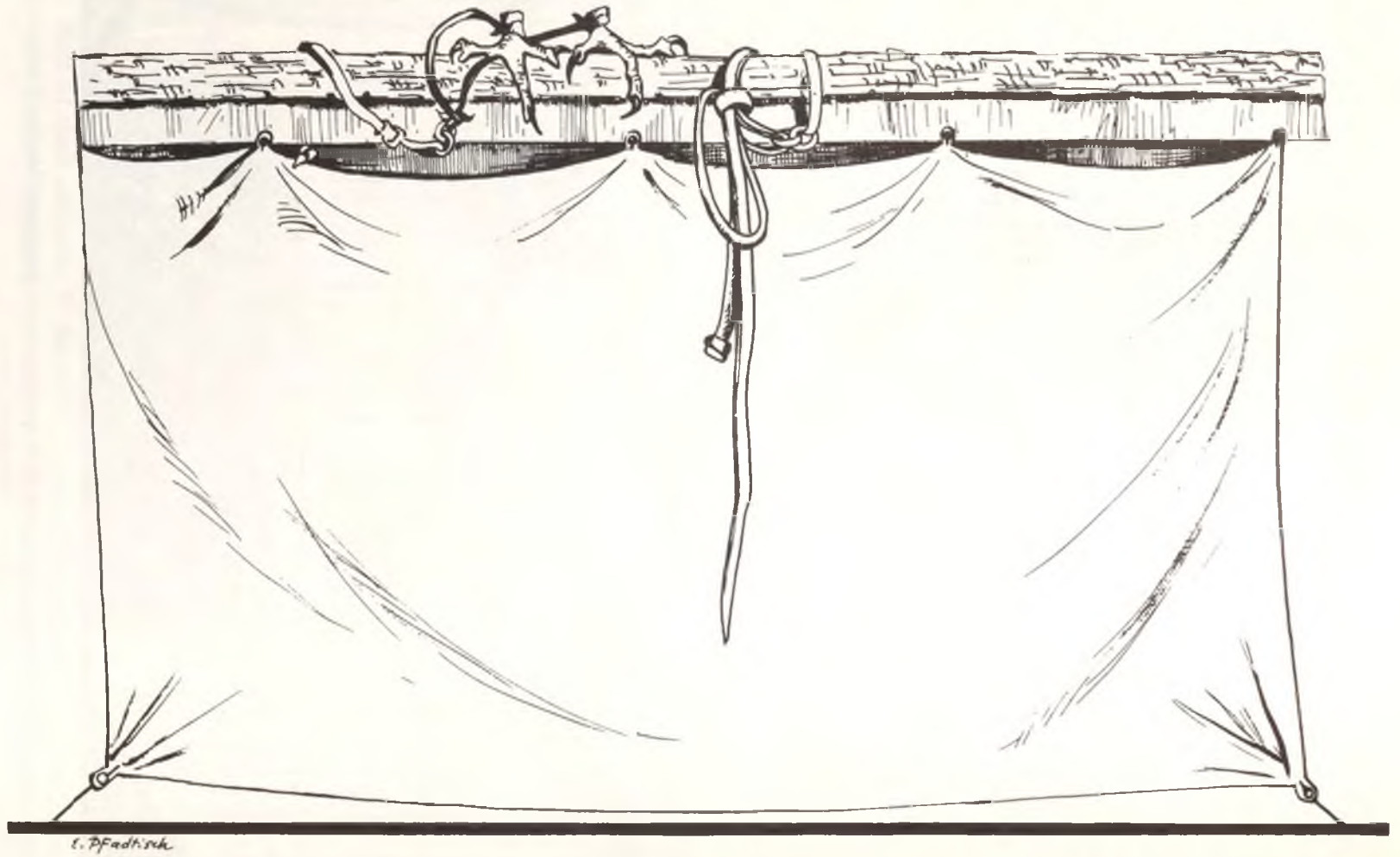

PLATE 137a.—Modern high perch with apron or curtain

ever, they are easily killed off by the application of equal parts of a strong watery decoction of tobacco and brandy or other spirituous liquor. The shoulders, head, and neck of the bird should be well moistened by means of a large camel's hair brush or pencil. One dressing may suffice to eradicate the pest; if not, it may be repeated as often as necessary. Some authors advise that tobacco smoke be blown among the feathers. Regular and frequent bathing will greatly assist in preventing these and most other parasitic attacks.

Internal parasitosis is rare in birds. When it occurs it is usually due to the presence of the common and relatively harmless *ascarides*.

Toxic diseases. Apart from tainted food, the swallowing of meat poisoned by lead (from shot), by salt, and by other preservatives is a fertile source of indigestion and even fatalities in both free-flying and trained hawks. Engelmann³ devotes considerable

³ *Die Raubvögel Europas*, pp. 686-87. Cf. Bibliography, below.

space to this subject. Scrupulous care in feeding one's hunting birds with fresh articles of diet is the best preventive of this form of poisoning. It is better to give a falcon less food than to feed her meat of a poor quality.

Fractured bones. Not only simple but compound and even complicated fractures of the leg bones may be almost as successfully remedied in the hawk as in man. Restoration of function so fully that the injured bird is as efficient a hunter as before the injury is another affair; it rarely happens. Accidents to the shoulder, for example, often result in a false joint, thus rendering the bird useless for sport. In simple fracture the bird should be held by an assistant and, after careful adjustment of the broken ends, the fractured bone should be adjusted and bound by a starch bandage or kept in place by strips of gutta-percha softened in warm water to fit the limb. Better still is a well-applied, dampened casing of plaster of Paris sprinkled on a woven surgeon's bandage.

METHODS, ANCIENT, MEDIEVAL, AND MODERN, FOR THE CAPTURE OF FALCONS AND OTHER BIRDS OF PREY

BY CAPTAIN R. LUFF MEREDITH

THOUGH the Emperor Frederick II had a contempt for bird trappers, even for the persons who caught the falcons he subsequently employed in hunting, this dislike was probably due to the crude or cruel trapping schemes ignorant dealers in captive falcons frequently employed, as well as to the harmful effects of these ill-advised methods on the birds themselves.

In the first chapter of Book I of the *De Arte Venandi* the imperial author denounces those ignoble followers of the noblest of arts who depend for their trade on the use of nets, snares, traps, bows, and slings. Doubtless, had the Emperor lived long enough or had the necessary time and opportunity, he would have given us what he regarded as the proper technique to be utilized in the capture of various falcons and other hawks for hunting purposes, a subject that, more than any other authority of his time, he was competent to discuss.

The following incomplete account of trapping birds of prey for sport is intended in a measure to relieve Frederick's descriptive shortage.

The best account of the many devices for securing birds for hunting purposes is that furnished by Schlegel and Wulverhorst in their comprehensive *Traité de Fauconnerie* (1844-1853), frequently quoted in this translation. Several falcon traps illustrating methods of capture have been borrowed from that famous monograph. Falconers particularly

interested in the subject should not fail to read carefully Schlegel's chapters. In passing it may be said that the more elaborate and complicated traps are not necessarily those best suited to the exigencies of modern bird capture; indeed, the simpler they are the more likely they are to be adopted in the present state of falconry.

Attempts to solve problems involved in trapping birds used in falconry have led to the exercise of ingenuity as well as of the trial-and-error method through many centuries. The mere capture of a hawk or falcon is not enough to serve the purpose of the sport. The bird must be caught without injury to even so much as a feather. Furthermore, the capture should be effected by one who has at least a rudimentary knowledge of the initial steps of training and handling the captive. He should also be thoroughly acquainted with the nature and habits of every species desired.

During most of the year all falcons are scattered far and wide over the country and it would obviously be impossible to seek them out and trap them; but during the autumn, when they migrate, there is some semblance of concentration along certain flight paths.

As the sight of a wild falcon is comparatively rare, it is obvious that the selection of a site for trapping where the terrain and other considerations lend themselves to best advantage is difficult. The regions where birds of prey are found are, of course, in their flight-path; so that the precise lay of the land will

influence the selection of a site for trapping. In general, it should be open country, so that decoys may be seen from afar; it should be fairly remote from dwellings or other disturbing factors likely to frighten the birds; and there should not be a superabundance of quarry, upon which passing falcons may prey without trouble. To an observing and alert person who also has the necessary knowledge of the birds he wishes to trap, these natural advantages will be taken in at a glance. If, in addition, it is known that hunting birds frequent a locality in numbers sufficient to make systematic trapping worth while, he may deliberately make his preparations there according to old and time-tried plans. On the other hand, if he does not have the advantages of terrain but knows only the incidence of the birds, he must modify his methods accordingly. Even though the appearance of a wild falcon is a rather unusual and unexpected event, there are other trapping outfits (besides the portable traps) that may prove fruitful; but the former snares involve the arrangement of a setup that must also be constantly ready.

In Europe and other countries where falconry has been long established, the best locations (along migratory paths) have long been known, although according to a note from Karl Mollen to the present writer, penned shortly before he died, the famous area of Valkenswaard has been spoiled by the establishment of numerous small farms. Nevertheless, recent attempts to revive hawk-catching have been made in the Low Countries but without much success. At present the acquisition of a passage or haggard falcon by a European falconer is largely a matter of chance.

In North America, where falconry is beginning to be popular, there are quite a number of localities that appear to possess advantages for capturing and training avian hunters if enthusiasts with the necessary qualifica-

tions were to undertake the task. So far, the falconers of America have not, for the most part, progressed beyond the stage of being qualified to train eyases, and they appear to be content with this accomplishment; as a rule, the captured fledglings are not even hacked. Consequently there has not been sufficient demand for wild-caught birds to induce anyone to trap them on an elaborate scale. It may be suggested, in regard to certain particularly good localities, that some resident may be induced to try his hand at trapping. Unfortunately, one of the requisites for this is that the site of operation be thinly populated. Where such is the case there are few inducements to permanent residence by other than rather untrained persons who have not the necessary talent for the task. The possibilities along these lines have not, however, been fully exhausted.

It has been suggested that in the lighthouse service there may be competent keepers to whose stations falcons migrate. A canvass might reveal officials who could qualify for this job and utilize some of their spare time and otherwise vary the monotony of their isolation by trapping hawks. Likewise the proprietors of game farms and avian refuges, who generally regard birds of prey as "vermin," might be induced to make an effort to capture birds of passage in a manner that will secure them uninjured rather than by the destructive and often cruel methods now in vogue. In this way, while removing the birds from the scene as effectually as destroying them, many valuable falcons could be salvaged for falconers. A nominal sum might be quoted as the value of such captured birds, and this inducement might be a sufficient incentive to trap them in a way that will secure them unharmed.

It is a wonder, considering the constant warfare waged by man against birds of prey, that they survive in the numbers they do. At all seasons they are considered legitimate

per amissionem sua rem ad
 uenientem ante statim pfe
 rit sonos consuetos falconi
 7 apponit natio. ut pedibus
 eius ut attendat natio. 7
 non rei. aduementa. 7 di falco
 attendit ene natio ipse
 falconarius. pariter q res illa

statim q res transierit ante
 tatur natio. 7 falcone 7
 abscondatur in loco debito.
¶ Et si in hoc qd sup
 ruis dem e videtur q minus
 ualid esset si res transierit
 an hanc falcone qm natio
 opponitur hoc modo. cu sup



sup manū tenuerit ipm. uill
 prem unde uidat rem d. qui
 timuit 7 expulit. 7 sic late
 reducat ad terribil sup ma
 nu. tam q. accit q. res d. qui
 timuit. sic in illo loco ubi pte

tingendo. sine non. cu filio
 fuit pedes subueniendi e
 ficut pedes. 7 sine mea re
 trahendis e falco sumit ve
 in pedes. Illis ad q. fuit
 pte mea. qui sunt rotue

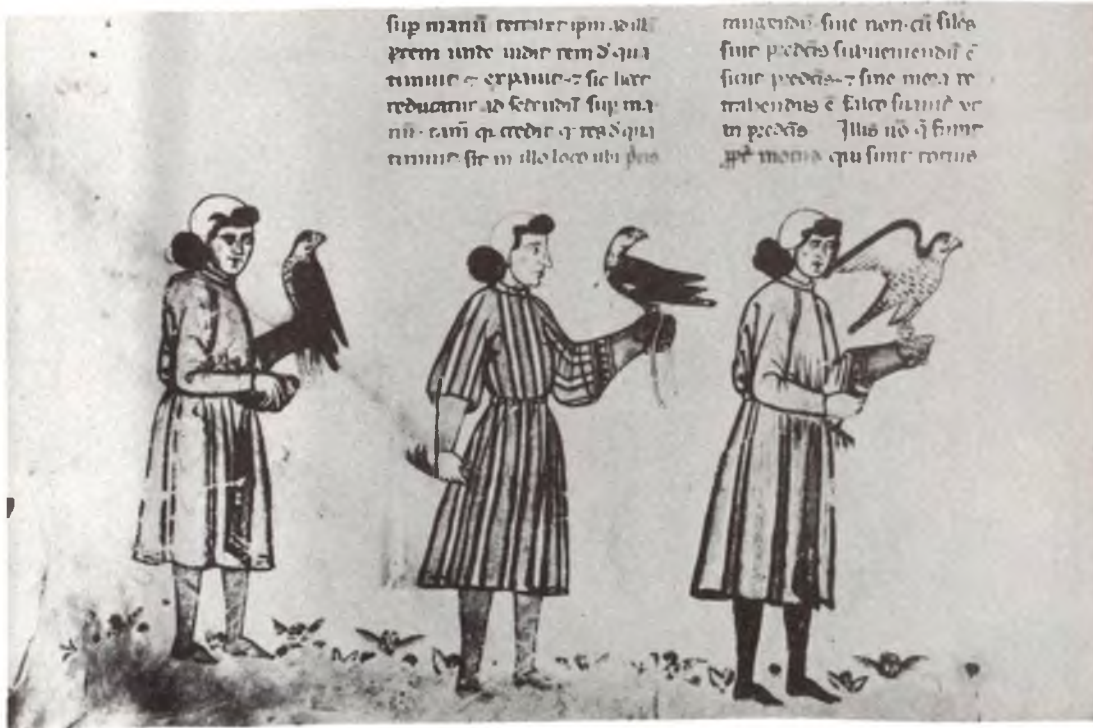
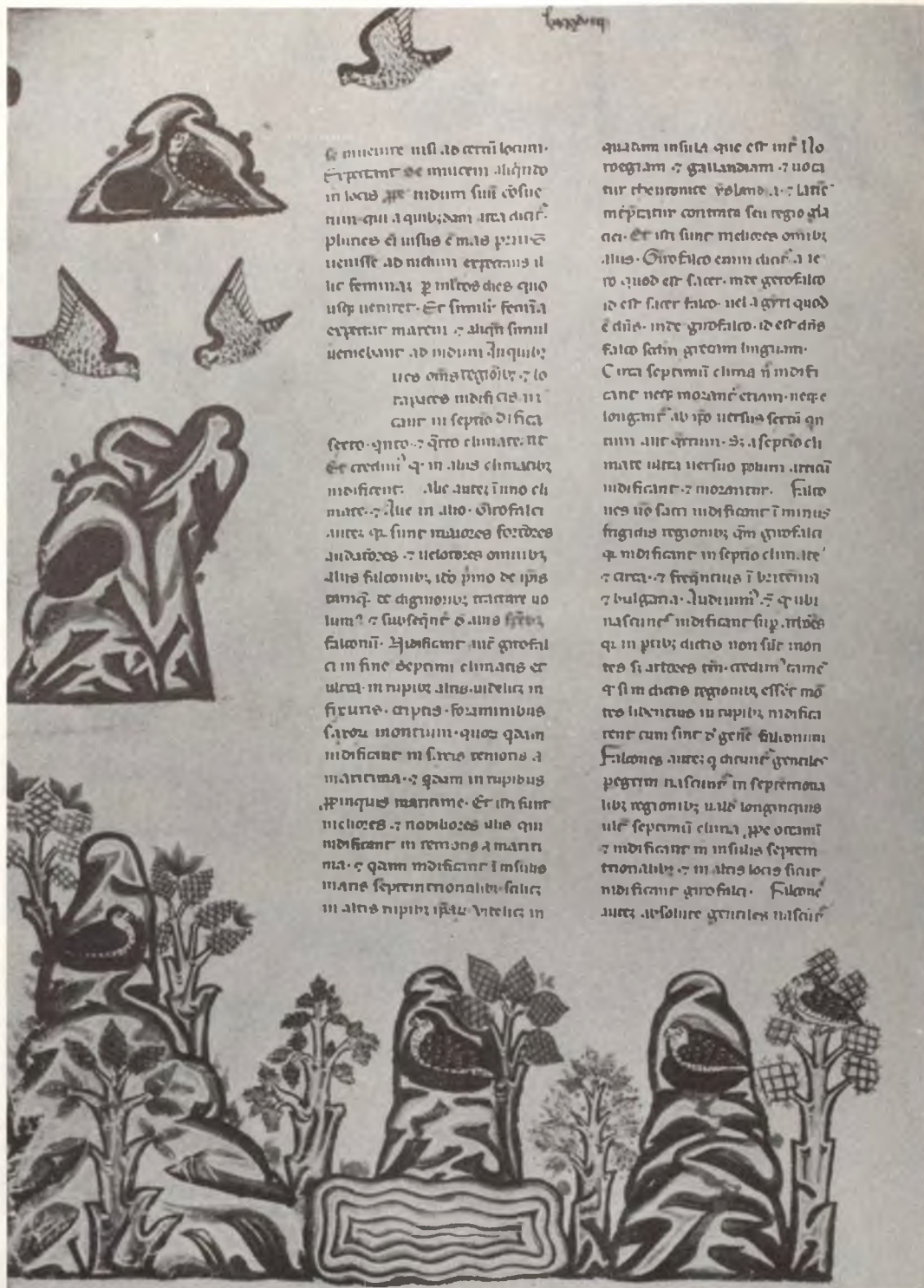

PLATE 138.—Figures of falconers illustrating the proper handling of falcons to prevent bating. From the Vatican MS. Pal. Lat. 1071, fols. 89 (above) and 89^v (below).



Et mouere nisi ad certū locum.
 Expectant de invicem aliquid
 in locis p̄ indium suū cōsue-
 tum qui a quibusdam arca dicit̄.
 plures et iustus et mas p̄uī
 uenisse ad nichūm expectans il-
 lic feminā p̄ multos dies quo
 usq̄ ueniret. Et similit̄ femina
 expectat maritū. et aliquid simul
 ueniebant ad modum aliquib;
 ues om̄s regionib; et lo-
 ca ues indici ad in-
 caur in septio distica
 serro. q̄nto. et q̄nto climare. ut
 Et credim; q̄ in aliis climatib;
 indiciant. Alii autē in uno cli-
 mare. et Alii in alio. Grosfalco
 autē q̄ sunt maiores feroces
 iudicantes. et ueloces omnib;
 aliis falconib; itō p̄mo de ip̄s
 om̄q̄ et digniorib; tractare uo-
 lum; et suscipiē et aliis sp̄ib;
 falconū. Indiciant autē grosfal-
 ci in fine septimi climatis et
 ultra in rupib; aliis. uidelicet in
 figuris. et p̄ns. foraminibus
 saxoꝝ montium. quos quādam
 indiciant in hinc regionis a
 manna. et quādam in rupibus
 p̄p̄nquis mannae. Et ita sunt
 meliores. et nobiliores alio qui
 indiciant in regionis a manna.
 et quādam indiciant in insulis
 mans septentrionalib; falci
 in aliis rupib; ip̄te. videlicet in

quadam insula que est int̄ Ho-
 roegiam. et gallandiam. et uoca-
 tur theuonice. et uolandi. et linte.
 mēp̄tatur contrata seu regio gla-
 cia. Et ita sunt meliores omnib;
 aliis. Grosfalco enim dicit̄ a te-
 ro quod est sacer. inde grosfalco
 id est sacer falco. uel a ḡrri quod
 ē dñs. inde grosfalco. id est dñs
 falco. sc̄m̄ ḡrriam linguam.
 Circa septimū clima si indici-
 cant necq̄ moxant̄ etiam. neq̄ e-
 longant̄. ab ip̄o uersus septū q̄n-
 tum aut q̄rtum. Si a septio cli-
 mare ultra uersus solium. amā
 indiciant. et moxant̄. Falco
 ues uō facti indiciant in minus
 frigidis regionib; q̄m grosfalca
 q̄ indiciant in septio climare
 et arca. et frequētia in uerticibus
 et uulgata. Judicim;. et q̄ ubi
 nascunt̄ indiciant sup̄. mōdo
 q̄ in p̄nib; dictis non sūt mon-
 tes si artates t̄m. credim; tamē
 q̄ si in dictis regionib; esset mō-
 tes iudicant̄ in rupib; indici-
 rant̄ cum sint d̄ genē falconum.
 Falcones autē q̄ dicunt̄ gentiles
 p̄p̄rim nascunt̄ in septentriona-
 lib; regionib; uel longinquas
 uel septimū clima. p̄p̄tanti
 et indiciant in insulis septem-
 trionalib; et in aliis locis siur
 indiciant grosfalca. Falcones
 autē uersus gentiles nascunt̄

PLATE 139.—Illustration of falcons' nests. (Vatican MS. Pal. Lat. 1071, fol. 49r)

fois il a tendent l'un l'autre
 es leus pres de loz nri. qui
 ont a construere qui dau
 cuns est apeler auz. On
 a veu plusieurs fois que le
 maales uent p'enters au
 ni et atant anqui la fenel
 le par plusieurs iours jul
 ques elle ramgne et la fe
 midle aussi atant le maale
 et aucune fois viennent
 en samble au nri. A parol
 le cinq regions et es que
 leu il font loz nri.

Que li oisel de proie
 font loz nri on septi
 me seze. quinz et quart
 angle dou monde et troi
 que es autres angles il
 font loz nri. Li aucun en
 l'angle et li aucun en l'
 autre. Li gersant car il font
 li plus grant li plus fort
 li plus hardi et li plus ef
 nel de touz les autres fau
 ont et pour ce on gmance
 mant de loz ame des plus
 nobles et des plus dignes

nous volons traictier de
 en leuant des autres esloes
 des fiaucons. Li gersant font
 loz nri en la fin dou septime
 angle et outre en raches hru
 res cest a sauoir en breus
 et creptes et es petuis des
 roches des montaignes de
 quez aucun font loz nri es
 roches es loingnes de la ma
 rine et aucunes roches pro
 chaines de la marine et ces
 font milloz et plus noble q
 est qui font loz nri. Es loig
 nies de la marine et aucun
 font loz nri es illes de la mer
 de septentrion cest a sauoir
 es hautes roches de celles et
 aucun font loz nri en vne
 ile qui est entre mozatnges
 et guellande qui est a psee
 en trois illande et selonc last
 regions de glace ou conrate
 il font li milloz de touz les
 autres. Gersant est di de
 gero qui vuit auant a
 dire que sans et de faloo
 qui dauc auant a dire en



PLATE 140.—Copy of the preceding plate in the Bibliothèque Nationale MS. Fr. 12400 (fol. 80).



fambis et lignis demittatur de
 ciampine rapis usq. ante cap
 tam in qua est. Acci in di. ceum
 et utriusq. accipie eos et sunt
 ali. qui alios modos creantur
 accipiendi ad modum ubi am q
 sic. In autem appetendi sunt
 in quibus dicitur diligenter omis
 et cautela. colubetur. dum capri
 salubriter parentur ad locum
 in quo nutriendi sunt. *De quibus*
et quomodo loci in quo nutriuntur.
 et modo nutriendis eorum —
 locus est modus in quo ha
 bentur creta et modis
 Dicitur enim quomodo
 hanc modus est locus in quo nutri
 entur. et quomodo nutriendur
 dicitur dicitur. In modo sicut
 quod habentur. postquam dicitur
 nudum. locus itaq. in quo nutri
 endi sunt pulli falconum sic in
 loco campestris dicitur. At artos
 bus. et a siluis. in turri. Aut in
 domo alia solitaria. nutriendur
 cum a parente suis in. Alii
 locis longinquis a siluis. Preterea
 falcones naturaliter diligunt
 loca campestris multitudine
 artorum creta. et in talibus
 locis veniunt. Unde si nutrie
 tur in siluis. aut in artos.
 postquam crevisserit. licet non
 dum firmi hinc et illic et sum
 locum volent ad loca cam

pestra. quibus naturaliter conder
 tantur in eis. neq. redirent li
 beriter ad locum in quo nutrie
 bantur quibus pulli falconum
 sicut et creta. autem dicitur ad
 hoc sunt tenent. nutriendur p.
 ali. et aliquo aduoluerunt et
 consuetudinem habent rede
 undi ad locum in quo nutrien
 tur. et quo sequit. q. non possit
 pulli falconum de facili reuolue
 ri. cum uolentis in campestribus
 morantur. qm. ad siluosa loca
 et qm. ad artos loca artos plena
 reuertent. et ex usu recedendi a lo
 co artoso in quo nutriendur.
 possunt aufigere. et amitti. De
 loco ubi in quo nutria dicitur
 pulli. accipitur locus est. ut dicitur
 in creta de accipitibus.
 Item in uero loco ubi auentur
 nutria possunt pariter ex lo
 co pulli ad similitudine mdi
 sui. et de simili natura de qua
 erat mdus. aut d. ita auentur
 in. Locis autem hic pulli reter
 esse aptus in talibus paribus. et
 uenturum septentrionaliter ori
 entalem. et occidentalem. requirit
 et solum ab oriente. et ab occiden
 te. a parte uero meridi. sit
 eluis ne uidentur uenti no
 dent. et dissoluto humo
 res et capta. redendo eos pugn
 ores. et debiles. et ne cito soli

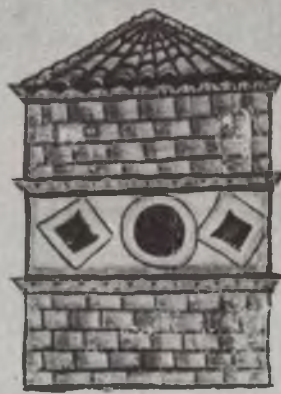
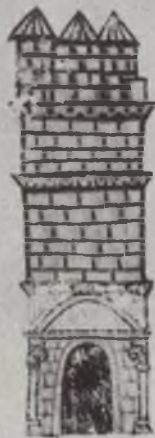

PLATE 141.—Falconers lowering a man over a cliff to rob a falcon's eyrie; below. types of Medieval mews. (Vatican MS. Pal. Lat. 1071, fol. 58^v.)

targets for the guns of farmers and pseudo-sportsmen, indeed, to be shot by anyone owning firearms. "Wild as a hawk" is an expression as true as it is time-worn; but this feral quality is the sole salvation of the various birds of prey, although it does not help the trapper in his efforts to catch them. The fact that wild hawks are occasionally caught accidentally in strange and unexpected ways is apt to lead to underrating their powers of observation. Hence it is best not to count too much on any trapping device; at best one only hopes for results.

Traps and snares range all the way from simple nets and devices used on the spur of the moment, for the occasional hawk that has been casually sighted, to elaborate constructions in good locations where hawks are of fairly frequent occurrence.

The Dutch method of trapping (see Plate 142), so-called because of its long use in Holland and the high degree of perfection to which it was brought there, is by far the most elaborate and at the same time the most complicated of all the schemes for securing birds of passage. Nothing is left to chance; and at first glance it might appear that the natural wariness of the migrating birds to be trapped has been overemphasized. It was used, however, continuously, year after year, in North Brabant for securing passage falcons to fill orders from all over Europe. In addition to the elaborate setup, it required an operator with qualifications beyond the ordinary. He had to possess great patience, as he might have to sit confined in a tiny sod hut from dawn to dusk for several days without any favorable results whatever. He could not relax his vigilance for a moment, but had to be constantly alert and able to interpret the actions of his living sentinels. In his hut were a number of ropes which had to be operated at the right time and in the proper sequence. To anyone who has tried even a simplified form of this method it is apparent how easy

it is to work the wrong line or make some other mistake at that exciting and tense moment when the wild falcon is approaching the live decoy.

The most complete and detailed description of the Dutch method is given in Schlegel's *Traité de Fauconnerie*, here given *in extenso* because of its importance in the history of falconry and because it was the plan preferred and successfully employed at Valkenswaard by several generations of the well-known Mollen family of falconers:

The vast plains that border Germany and extend through Holland and along the Atlantic coast of France to the frontiers of Spain present the terrain most favorable to the Dutch type of trapping. Here in the fall of each year there appear passage falcons who, having spent the summer in a cold country, cross these open areas to pass the winter in a milder climate where they may also find an abundance of food. It is to these plains that falconers betake themselves, at the time of the annual migration, to arrange their nets and other traps, sure of attracting to them all falcons that frequent these localities for a distance of several leagues around.

Having chosen a suitable locality, a sod hut is constructed, the interior of which is about four and one-half feet in height. A wagon wheel placed across the walls serves as the framework for a (sod) roof. The entrance faces to the east, because the east wind rarely brings rain. It is closed with a fairly large door that has been carefully covered on the exterior with sod in the same manner as the rest of the hut. The roof sods are disposed in such a manner that by removing some of them an oblong opening is formed which serves as an observation window. Opposite this hut, about twelve feet from it and about fifteen feet from each other, are placed two sod mounds, on the tops of which are tethered shrikes that serve as sentinels. Each mound is about five feet high, the top platform being

about two feet in diameter. Half this latter space is vaulted over so that it forms a small box, with an opening toward the falconer's hut, through which the sentry shrike may seek refuge when threatened with danger from an approaching falcon. Three small, semicircular hoops, the ends of which are stuck in the turf, are arranged around an opening at the edge of each platform. These hoops serve as perches for the shrikes, which are tethered to the center of the space. In addition, a larger hoop is placed above each of the three mounds to guard the shrike from seizure in its retreat by any of the (short-winged) hawks.

When this part of the preparations is completed, there are erected at a distance of a hundred and thirty feet from the falconer's hut, and about sixty feet from each other, three heavy poles, twenty-five feet long, with a rope line attached to the top of each running to the falconer's hut. A live pigeon, fitted with jesses, is attached to the line from the first pole. Near the base of this pole a small turf hut is constructed to serve as a refuge into which the pigeon may escape or from which it may be withdrawn by the falconer when the main line is pulled taut. To the second line, in the same manner a falcon that, because of a bad disposition or for other reasons is considered of little value, is secured. Attached to the same line, a short distance away, is a large bundle of feathers. The third pole is furnished with a similar tuft of feathers and an artificial falcon made of wood.

This latter device is usually omitted (as in the present drawing). In fact, lacking a wooden decoy the plan may be made to work with no other than the usual decoy pigeon, although the omission renders the scheme less certain to attract distant wild falcons.

Arranged around the hut, so that they may be observed at a distance of a hundred yards, are three bow-nets. One is placed to the northwest, one to the south, and the third to the

northeast. The bow-net consists of two semicircular bows of iron or wood hinged so that they together form a circle. They are covered with loose but strong netting. Openings (meshes) in them are about two inches square, and the whole net is dyed the color of the ground. In setting the net, the diameter through the hinges is placed at right angles to a line running from it to the hut. The far half of the bow is sunk slightly into the ground and pegged down securely. Then the free half is folded back over the pegged half and the netting is tucked back so that it is out of the way. To one side of the free half a wire is attached which runs to the hawk-catcher's hut, through a hole in the base of the net, and by means of which it may be pulled over. When ready for use the net is covered with straw or herbage similar to surrounding growths. In the center of the space covered by the net (when it is sprung) there is driven an iron peg with a smooth eye in the top. This is driven flush with the ground. A line runs from the hut through this eye and a live pigeon is attached to the end thereof. This pigeon is placed in a small turf shelter arranged about thirty feet behind the net and kept there by a piece of loose sod, which can be pulled down and the pigeon drawn out at the approach of the wild falcon.

Everything in readiness, the falconer hides himself at dawn within his hut, there to remain throughout the day until sunset. Seated upon a chair in his narrow cubicle he cannot relax or devote himself to any occupation whatsoever;¹ his only pastime is his pipe. His eyes are constantly on the shrikes. From time to time he works the line which moves the wooden falcon (if there be one) to attract the attention of any wild falcon or other bird of prey in the distance that is on the lookout for quarry.

¹ Some of the Dutch hawk catchers who were cobblers and makers of hawk's furniture whiled away the time in the hut at their trade.

Now and then, believing the decoy falcon to be one of its kind also in pursuit of prey, some errant bird, urged by jealousy or by the hope of stealing some food, hastens toward the spot. As the falcon approaches high in air, the shrikes point toward it and the falconer lets the wooden falcon fall to the ground. Since this latter decoy would not deceive the approaching wild falcon very long, the watcher makes haste to work the decoy live falcon by means of the line attached to the middle pole, and then exposes also the pigeon at the first pole. More and more, as the wild bird approaches, the shrikes indicate by their agitation the enemy species. If the latter is a kite or an eagle, they do not concern themselves greatly; if it is a buzzard, they jump from the perch and utter loud cries; finally, if it is a short-winged hawk or other species of falcon, they show the most pronounced signs of alarm, uttering loud cries of distress and retreating within their shelter. It is at this moment that the falconer drops the line to the pole pigeon, allowing it to escape within its shelter, and at the same time withdraws from its refuge the pigeon behind the bow-net nearest the free flying falcon. The pole pigeon having disappeared, the falcon mistakes the bait pigeon for it and loses no time in seizing it.

During the time she is killing the live pigeon and before it has ceased its struggles, the falconer draws in the line to which it is attached, thus pulling both pigeon and falcon up to the eye of the peg driven in the center of the bow-net. The falcon will not suspect this movement, as a struggle is natural with a strong quarry, but will hold on all the tighter. When both birds are directly in position, as indicated by a mark on the line within the hut, the watcher, quickly but deliberately, pulls the wire which operates the net and envelops them both. Having previously provided a loop in the wire (or other means of securing the end in the hut so that in her

struggles the falcon cannot raise the edge of the bow-net and escape), he runs out as fast as possible to take the imprisoned falcon from the net and to reset the trap.

To disengage a wild, newly caught falcon from the net requires no little finesse and dexterity, both to prevent injury to the bird (which is the first consideration) and to escape painful lacerations from the needle-like talons (strong as steel) and the razor-edged beak of the falcon.

After she is removed from the net a rufter hood is put on her head and she is slipped into an elastic sock from which the toe has been cut. The hood has an immediate, quieting effect on the captive, and the sock effectually confines her wings and prevents further struggles. Once within his hut the falconer lays aside his prize and again devotes his attention to his traps.

Although the method described is almost infallible in the hands of an experienced person, it can readily be appreciated how in other hands a slip-up may occur. The lines running into the hut are confusing, and careful rehearsal and drill are necessary to operate them consecutively and at the proper time. An excitable person is quite liable to pull the wrong line, or he may allow the pole pigeon to be caught by the falcon; or, instead of drawing the pigeon from behind the net, he may, in his excitement, pull the net over and frighten the hawk away. Once she has been frightened in a particular locality, there is no future chance of catching her there, although she may be trapped in a similar manner at some other spot. Falcons seem to associate a fright with location rather than with a variety of trap.

Most of the other methods of trapping depend in a large degree on chance, on "fisherman's luck." In employing traps that are left in place and inspected only at intervals there is more chance of catching some valueless species of hawk than a good falcon. The

fact of their being sprung or occupied by another species, more frequently than not, may prevent the capture of one which is desired.

Roughly, the devices, apart from the Dutch method, for taking wild falcons may be divided into two classes: first, those that are used when likely hunting birds are by chance sighted in the field; and, second, those that are left baited in a favorable locality.

Most of these traps require that at all times the falconer have with him a live decoy and other apparatus, which must be easily carried and quickly prepared, as the opportunity for a capture is fleeting.

A device extensively used by Arab and Persian falconers is the Dho-gaza. This consists of a silken, neutral-colored net about five feet square with a two-inch mesh. The top of this net is serviced so that it will hang naturally and vertically between two light poles driven firmly into the ground. A cord runs from the top to the bottom of each pole. It is securely tied thereto and woven in and out of alternate meshes of the net; or it is run through light brass rings and fastened to the vertical edges. This trap, then, consists of a net that is free to gather along the edges and form a purse when pulled free from a light clip that secures it to the top of the pole at each corner.

A variant of this trap has the cord upon which the net gathers made in one continuous piece, running down one vertical edge, along the bottom, and thence to the top of the other pole, where it is tied. In this modification it is necessary to clip the corners lightly to the poles at each bottom corner. The latter arrangement has a slight advantage, inasmuch as it allows the net to purse into a more complete pocket when struck by the falcon. The method of setting is as follows: When a perched falcon is observed, the net is so placed that the plane of the net is at right angles to the line from the net to the bird but at such a distance as not to frighten her. A live decoy (with jesses) is then fastened a

couple of feet from and on the side of the net away from the hawk by means of a peg driven in the ground. This decoy is made to flutter, and the falconer then retires to a safe distance from it. If the waiting falcon is hungry and of a bold and not too suspicious disposition, she is more than likely to stoop directly at the decoy. She will not notice the intervening net until she has hit it and, unable to check her momentum in time, caused it to pull loose from the clips holding the corners and purse around her. All the falconer then has to do is remove her from the net.

This device is fairly certain of results in those Oriental lands where birds of prey are generally tamer and less suspicious than in more populous and northern countries. It can also be used to advantage in capturing young peregrines in the vicinity of the eyrie after they have been trained by their parents for a month or so but have not yet acquired a suspicion of man and all his works. It could be used in Greenland to catch gerfalcons, who frequently perch conspicuously in the vicinity of the settlements and are not very shy of man. In certain parts of Greenland native falcons perch on wireless towers; but, instead of catching them, as could easily be done, the residents shoot them in a shameful number, under the impression, more than likely mistaken, that they tear the pelts of blue foxes caught in their traps. (The probability is that when the skins are destroyed it is done by snow owls, and mistakenly attributed to falcons.)

The dimensions of the Dho-gaza given above are the minimum. The nets may be larger, but they are then not so convenient for transport. The meshes should be as large and made of as fine thread as possible (consistent with strength) to suit the species of falcon it is intended to trap.

Various modifications of this type of net, embodying the same principle of operation,

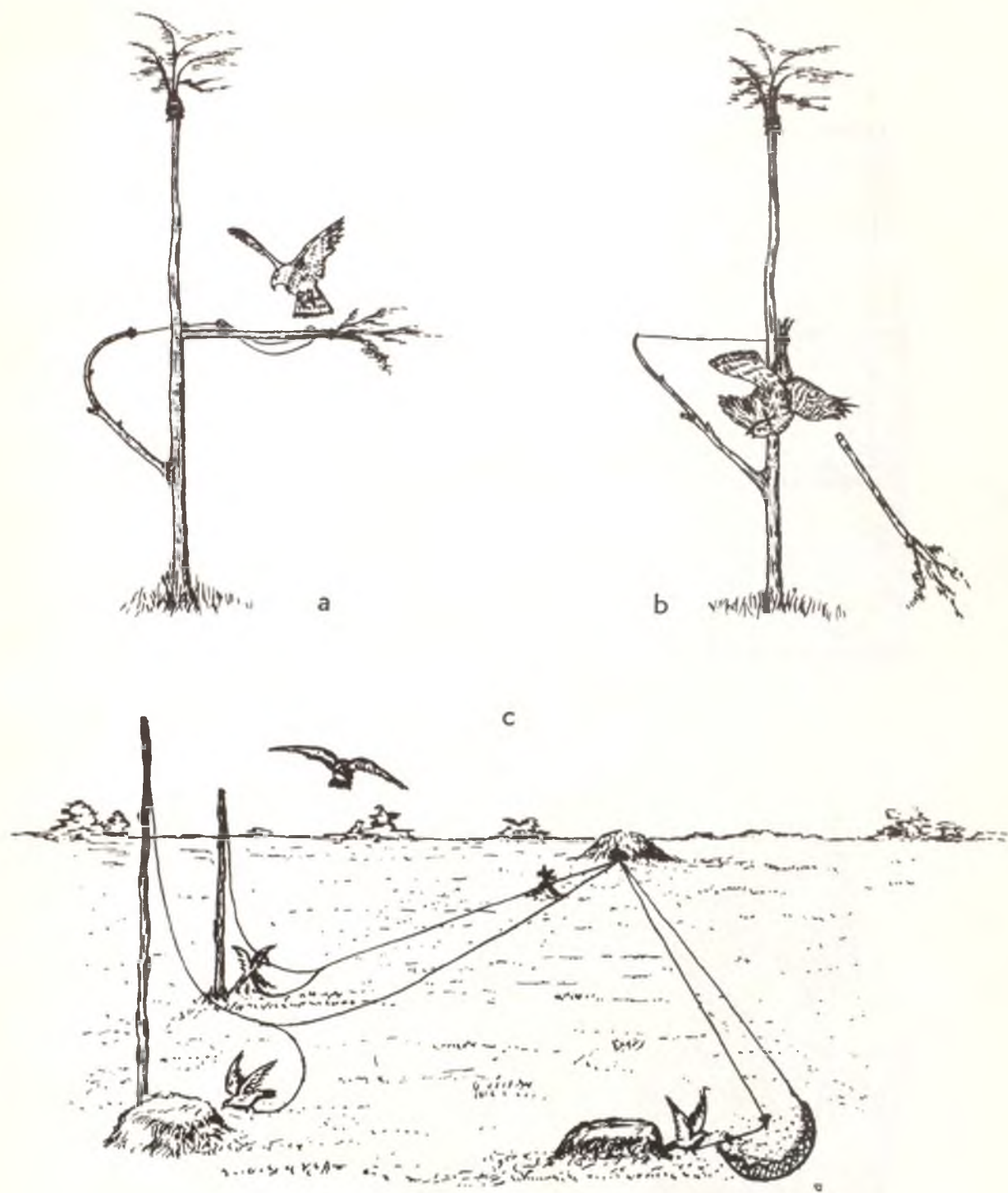
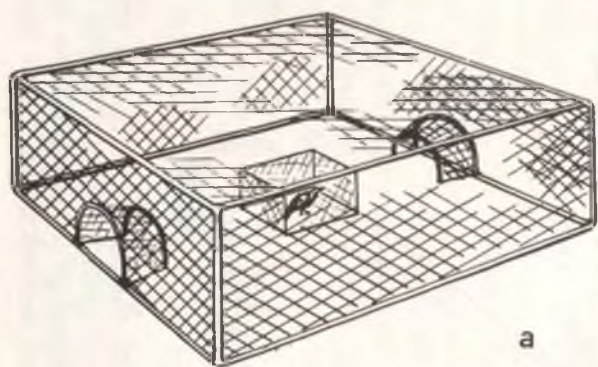
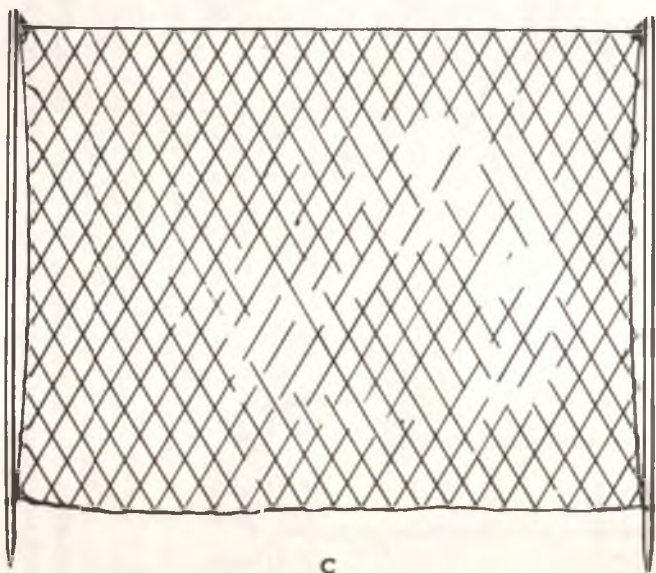

PLATE 142.—(a) Trap-noose for capturing falcons; to be set in a locality frequented by birds of prey. The free-flying falcon, landing on the spliced branch, springs the trap, is caught in the noose, and is held until the waiting falconer quickly arrives and releases it. (b) Shows the snare after springing. (c) Arrangement for capturing migratory (passage) birds of prey, the so-called Dutch method once used in North Brabant. (After Meredith.)



a



c



b

PLATE 143.—(a) Stationary trap for the capture of falcons. The bird of prey entering the wire cage in pursuit of the decoy is unable to find her way out. (b) Diagram showing shape and size (usually 5x4x4 feet) of a simple avian trapping cage, covered with stout (but soft) cord mesh. Almost any caged or pegged live decoy (in the center of this box-like container) serves to attract falcons, who, in their efforts to strike the decoy or to escape, after gorging the lure, readily become entangled in the soft mesh covering of the trap until rescued by the falconer. (c) Plain net for catching birds of prey. It is warily set in front of a perching hawk, with a live decoy "planted" either in front of or behind the net. The latter is camouflaged by coloring it so that it is made almost invisible. The wild bird, stooping to the tethered quarry, fails to see the net until too near to prevent entanglement, and so becomes a captive for the concealed falconer, who hurries up to release the struggling bird. (After Meredith.)

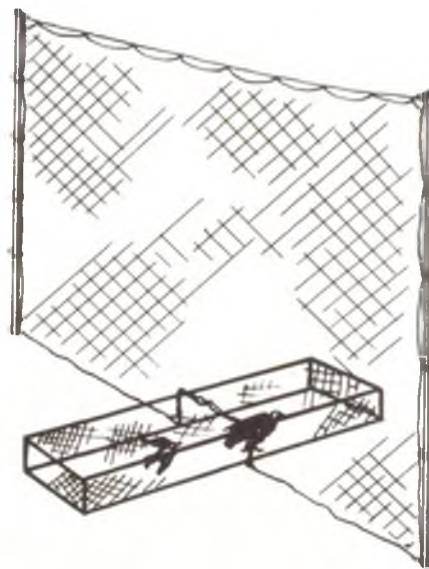
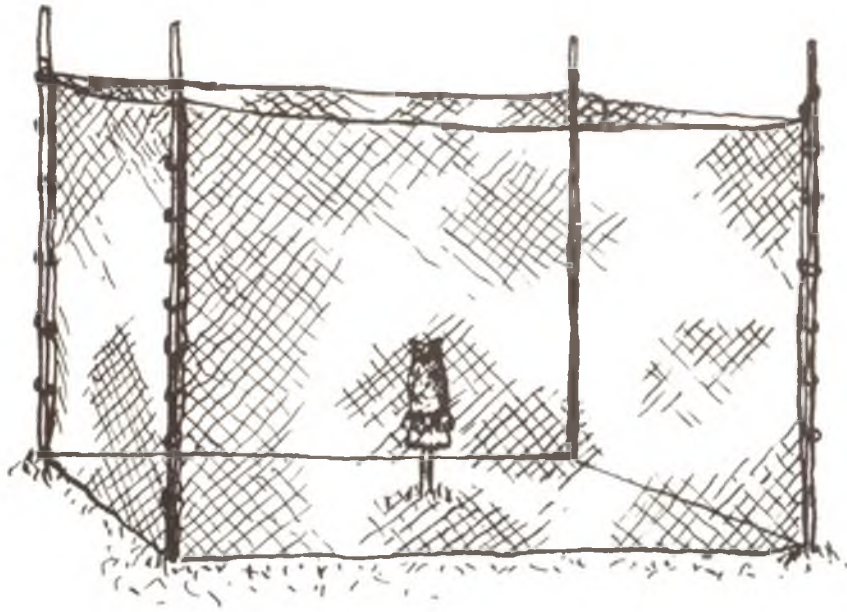

PLATE 144.—(Above) Box-cage trap for falcons. In this device, a small owl is tethered at the center of a cage (4x8x6 feet), which is covered by stout, soft, cord mesh attached by metal rings to the corner posts, 8 feet high. The rings are affixed to the lateral portions of the net so that the latter can be raised for entry by the falconer. A hawk, plunging down on the decoy, is caught in the meshes of the net. (Below) One of numerous modifications of the Dho-gaza, an Oriental device for catching hawks. This is made of a frame eight feet square, provided with a neutral-tinted silken network of about two-inch mesh. At right angles to this frame is a cage of netting 5 feet long and 15 inches high, containing several live decoys.

Any hawk, stooping for one of the decoys, is pretty sure to be caught in the silk meshes. (After Meredith.)

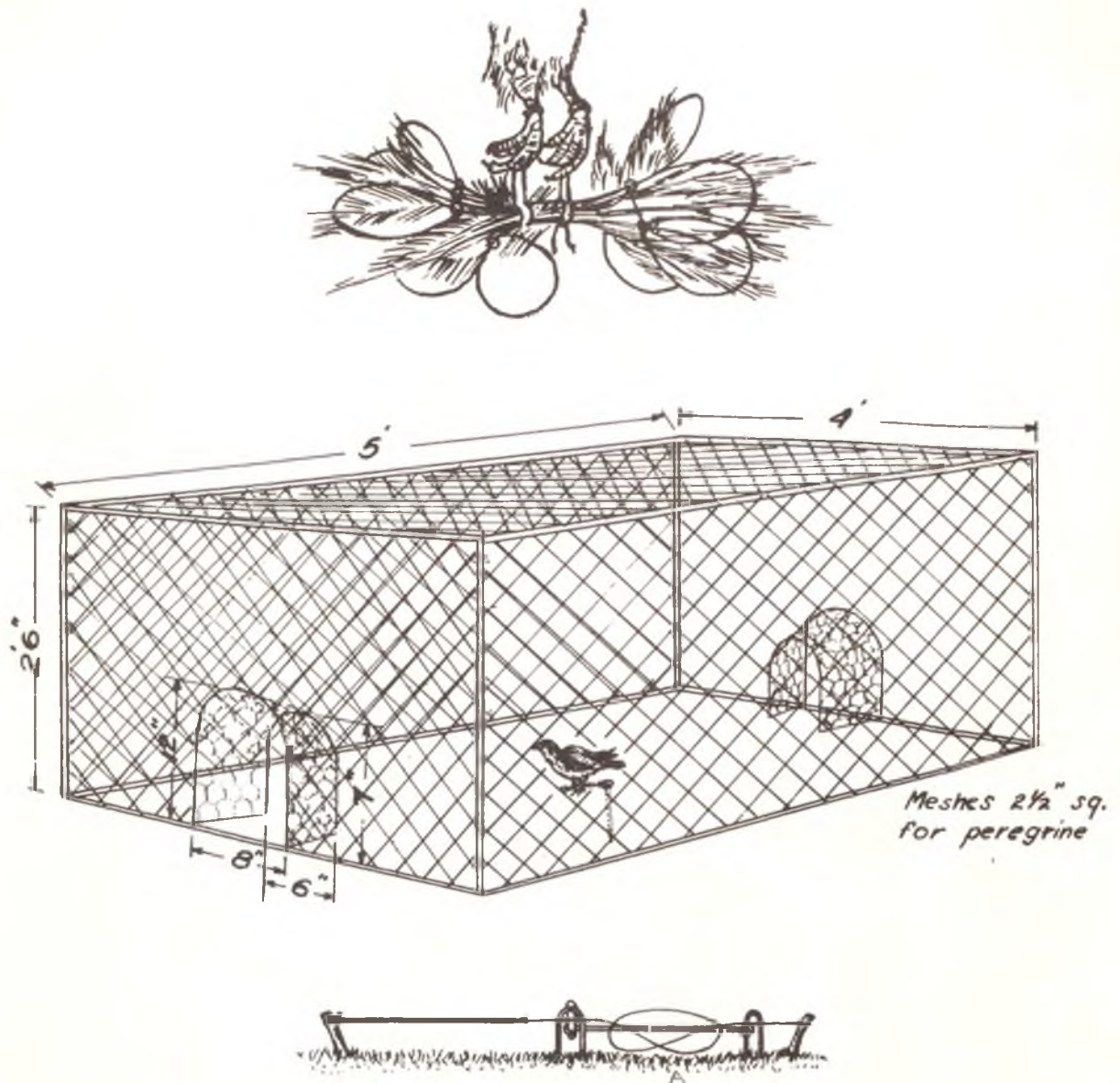

PLATE 145.—(Top) Device for capturing falcons. Fine catgut slip-nooses are attached to a bunch of feathers (simulative of a recent quarry) and these are attached to the jesses of a tame, trained (decoy) falcon. On the appearance of a wild hawk the decoy is thrown off, to be pursued by the free-flying bird intent upon stealing the supposed prey. Overtaking her, the latter is caught in the nooses. Thus entangled, both birds are brought to earth, to be released by the falconer lying in wait. (After Meredith.)

(Center) General design of Demeritt hawk trap: entries may be of chicken wire, but the rest of the trap must be covered with twine netting (preferably tarred) to avoid injury to the captured hawk. Actual dimensions and form may vary according to species desired and materials available. Live decoy secured with jesses and swivel short enough to prevent the hawk from thrusting its foot through meshes and catching it. (Courtesy of Captain Meredith.)

(Bottom) Simple trap for the capture of birds of prey; to be set in a locality frequented by falcons. An unsuspecting hawk, alighting at A, springs the trap, draws taut the double slip-noose (made of fine wire, gut, or strong cord), which is firmly tied to pegs driven into the ground, and holds the struggling captive by the feet until the falconer arrives. (After Meredith.)

have been used with success. One of these consists of four upright poles about eight feet long stuck in the ground in the form of a square, each side of which is as long as the poles. The net is suspended so as to surround a certain area, in the center of which a live decoy is tied. The latter may be a pigeon or other live bait at which the falcon will stoop when hungry; or it may be an owl, alive or mounted, which will so arouse the ire of the falcon as to cause her to stoop and attack it. The trap is set in a likely exposed place and watched from a distance. One advantage of this scheme is that no matter from which direction the hawk stoops, she will encounter the net and become entangled.

Another modification is to make the Dhogaza about eight feet square. In its center is placed a cage of netting that contains live decoys. This container should be about fifteen inches in its short diameter and four or five feet long, with its midpoint under the net. Then, when the hawk stoops from one side or the other, the decoys will be sure to crowd to the opposite end. This movement will place them on the side of the net opposite the hawk, so that she must, perforce, attempt to go through it to get at them and in this act will become entangled.

In certain rare instances a falcon or hawk may be observed that has just killed a quarry which is too large to be readily carried away. When such an incident is observed, a snare may be set over the dead prey after the falcon has been frightened from it. If she is sufficiently hungry, she will return after all danger appears to be past and the snare will then entangle her feet.

Frequently wild falcons are attracted by free-flying, trained birds; or a wild one on the wing may be observed by watchers. There are several expedients to which one may resort and which may succeed in catching these untamed species. When enticed by a tame bird, the latter should be called down to the

lure as quickly as possible. To her jesses is then affixed a bundle of feathers among which are concealed a number of fine, gut slip-nooses. She is now released, provided, of course, the wild bird has not vanished over the horizon. To the feral bird the trained falcon presents the appearance of one carrying some sort of prey of which she may be robbed. If she stoops at the supposed quarry, she is almost certain to be caught by one of the nooses; the two birds will then fall down together, so that the stranger may be caught.

Another and somewhat similar method is to affix a leather harness covered with nooses to a pigeon, with a long cord attached to the bird. When a wild falcon is seen, the pigeon is released. The cord and harness now serve two purposes. They impede the flight of the pigeon to such an extent that the decoy is easily caught by the falcon and, after descent to earth, the cord will entangle with any weeds, bushes, or other obstructions over which it may be dragged. Then, if the hawk's foot has also been caught by one of the nooses, she may be taken.

Still another device is to release a pigeon to which a cord smeared with birdlime or similar viscous substance² has been attached. When the falcon strikes the cord, it will whip around and entangle her. Although none of these methods is infallible, each has proved successful in enough instances to make it worth trying.

The Shahin and other Indian falcons are generally caught by a device known as the "Eerwan." This trap consists of a thin strip of cane that measures the approximate alar expanse of the falcon which it is desired to capture. The piece of cane is tied securely to a dove or other quarry in such a way that the extremities of the cane project on each side of the decoy. The trapper smears the cane with birdlime. He also seals the dove,

² The modern "Tanglefoot" is an effective substitute.

who, on being released, soars high in the air and thus attracts the wild hawk. The latter hastens to strike its prey; but the birdlime, coming in contact with its wings, renders it helpless and both falcon and quarry tumble to the ground, whence they are taken by the falconer on the watch.

A curious plan for catching falcons is sometimes resorted to by the Arabs and other Oriental tribes in the desert. Having observed a falcon that has recently killed some quarry too large to carry off, the falconer frightens the bird away. A hole is then made close to the deserted prey in which a watcher lies, after being covered with sand by a companion, leaving only his nose exposed but one hand concealed under the wing of the dead quarry. When he is fully concealed, the companion retires out of sight. The falcon, thinking that danger is past, returns to her prey and, as soon as she has settled on the quarry and has started to deplume it, the Arab works his hand around and seizes her by a foot. If this is done carefully she will not become suspicious of danger, as she is accustomed to movement from the quarry, thinking it not quite dead.

The same principle is employed by natives of the Malay Islands. The hawk catcher conceals himself in a covered blind of brush and manipulates a live decoy held in his hand thrust through the foliage. When the lure is seized by a hawk, he catches her by the foot.

One recently discovered method of trapping falcons that is unique, in the sense that it appears at first glance to violate every principle of falcon trapping, was developed largely from the accidental capture of one or two birds. Mr. William W. Demeritt, of Key West, Florida, indulges as a hobby the banding of migratory doves. His dove traps are covered with chicken netting. He had been frequently annoyed by various birds of prey, among them the American pigeon hawk (*Falco columbarius*) and the duck hawk (*Falco peregrinus anatum*), alighting upon

the banding traps and frightening the captured doves so that they fluttered about and got within reach of these fierce birds, who, seizing one through the wire netting, would eat it piecemeal without removing it. Occasionally one of the falcons got inside the trap and was caught, after which in her efforts to escape she would generally damage herself by breaking her feathers and battering her cere and head against the wire. Mr. Demeritt then assumed the task of intentionally catching these birds and so modified his trap for the purpose, still using the chicken-wire netting. At the suggestion of the present writer the traps were enlarged and covered with twine netting which, being soft and yielding, would not injure the birds, either in their first impetuous stoop or after being caught. Each year these traps have been set and from two to four wild falcons have been secured. One year four duck hawks and thirty marsh hawks were caught; the latter were banded and released.

The following is a further description of the Demeritt-Meredith trap. While its dimensions may vary according to the size of the falcon it is desired to capture, it should in all cases be large enough to prevent any hawk from reaching in with her foot and seizing the live decoy centrally tethered within. A frame is constructed of wood or iron about four by five feet and thirty inches high. At each end (at the bottom) an arched entrance nine inches wide by a foot high is provided. Affixed to this is (in effect) a tapered hallway of chicken wire leading inward for (approximately) eight inches, where it terminates in an opening, similar in shape to the outside entrance but only six or seven inches wide and about nine inches high. In the center of the enclosure a live dove or pigeon is tied with jesses to a peg driven in the ground, or it may be confined in a small cage. The wild falcon, attracted by the decoy, may stoop and hit the netting. Finding herself blocked, she will at-

tempt to grasp her quarry through the netting from various sides or through the top of the trap; but finding she cannot anywhere reach the decoy with her foot, she will alight upon the ground and thrust herself through the netting until she comes to the entrance, which offers no bar to her ingress. Having once got inside the cage, she seems wholly unable to find her way out (on account of the funnel-like entrance), preferring to confine her efforts to escape through the outer sides and the top.

Just recently word has been received of the successful employment of a slightly modified form of such a trap by Captain Gilbert Blaine on his estate on the Island of Islay. A rough frame of willow branches is constructed on the ground and covered with netting. Wire funnel entrances are left in each end, and a pigeon is tethered inside. The first taking was a wild (haggard) tiercel peregrine, who succeeded in reaching in and killing the pigeon because the tether of the latter was too long; but she could not reach in and eat the decoy. So, after being frightened off, the pigeon was tied closer and left *in situ*. The following morning the tiercel was found in the trap, gorged. So far as we know, this is the first time this novel kind of trap, which originated in America, has been used in Europe.

An odd way of taking a goshawk or other of the yellow-eyed birds of the chase is described in the *Baz-Nama-Yi Nisiri*, the well-known Persian treatise on falconry, translated by D. C. Phillott. The passage is quoted here because of its historical interest rather than of its practical value.

"Should you happen to see a goshawk settle

on a tree towards sunset, keep a careful watch on it from a distance till three or four hours after dusk, and see that it is not disturbed. Then take a long, light pole of sufficient length to reach the hawk, and firmly attach to one end a horsehair noose; a span's distance below the noose fasten a lighted wax candle. Take this pole and proceed alone towards the tree on which the goshawk is sleeping, till within thirty yards of it. Now, with noiseless steps, advance very slowly for ten yards more, very, very slowly; then halt for some minutes; then extinguish the candle and wait another two or three minutes in the dark. Re-light the candle, and holding it aloft, advance steadily to the foot of the tree. Keep the lighted candle in front of the goshawk's face. Now, my son, pull yourself together and keep your eyes open; let hand and foot be steady; don't get flurried; think not you are after a goshawk. Say to yourself, 'It is the leaf of a tree, or a barn-door fowl.' Don't let your hand shake. This is the advice I give you; I cannot myself act up to it, nor do I believe that any falconer can. Well, hold the light close to the goshawk's breast. If she is asleep, head under wing, gently, ever so gently, stroke her breast with the horse-hair noose to awaken her, but have a care your nervous hand does not tremble but keeps the pole well away from her breast, or else she is off. Stroke her breast with the noose, ever so gently, till she withdraws her head from under her wing. Then pass the noose on to her neck, and pull her down to you."

A similar method is described in the *Boke of St. Albans*; but neither scheme will "work" with the brown-eyed birds of prey.

FALCONRY IN MODERN TIMES

BY WALTER SCHLÜTER

June 1939

LONG before the eighteenth century, European falconry was in full flower. It was the favorite sport of all classes and was regarded as a high art; especially at the numerous German courts it was enthusiastically practiced.

With the outbreak of the French Revolution, however, and during the long Napoleonic wars that followed, this aristocratic amusement died out; only in England has falconry been pursued with few interruptions (among them the years of Cromwell's Commonwealth) since the days of Ethelbert, in the ninth century. Founded in 1770, the Falconers' Club handed down the tradition of the sport, and flourished until the year 1838.

Probably the history of British falconry furnishes the most remarkable example of a succession of family falconers, running, as it does, through many generations. We refer, first of all, to the Fleming family of Barochan Tower in Renfrewshire. An ancestor received a jeweled hawk's hood from James IV of Scotland for outflying the king's falcon with his tiercel. The grandfather of the present owner was (1819) a celebrated falconer; the father kept hunting birds until his death in 1855, and the older gentleman first flew falcons in India. A well-known falconry picture is an oil painting by Howe in 1811, showing Fleming and his falconer. The famous John Anderson and all his assistants, including George Harvey, were associated with the Flemings and their Scotch falconers, hunting dogs, and horses. An engraving of this cele-

brated painting has been published by Tinley of Glasgow.

In 1771 the famous Royal Loo Hawking Club was founded in the Netherlands, incorporating English, Dutch, and French falconers under the patronage of King William III of Holland. Mainly through this club falconry came once again into its own. Every year, in May and June, a famous heron hunt was held on the moors of Vanloo. According to Dr. Swaen falcons were flown and herons captured from 1841 to 1852 as follows:

1841 . . .	44 falcons	287 herons
1842 . . .	44 falcons	148 herons
1843 . . .	36 falcons	100 herons
1844 . . .	14 falcons	128 herons
1850 . . .	16 falcons	138 herons
1851 . . .	18 falcons	130 herons
1852 . . .	36 falcons	297 herons

In 1853 the Royal Loo Hawking Club was dissolved, but soon after its foundation the club had commissioned a German, Professor H. Schlegel, and a Dutch naturalist, A. H. Verster de Wulverhorst, to write a work on falconry. As a result, in 1884-53 the famous *Traité de Fauconnerie* was published. This monograph is one of the rarest, most exhaustive, largest, and most expensive treatises on the subject in any language. It is much sought after by connoisseurs, especially on account of its fine illustrations. The birds are lithographed, of life size, and in their actual colors.

For more than a hundred years the Dutch

school of falconry was pre-eminent in Europe, and during the eighteenth century Holland was the chief source of trained and wild (passage) falcons as well as of expert professional falconers, many of whom were employed by foreign gentry or were attached to various European courts. The most famous of these professional sportsmen were raised or trained in Valkenswaard, a small village brought into prominence chiefly by a single family, the last of whose race, K. Th. Mollen, died in 1937. For nearly a hundred years this famous trainer of hunting birds and his father before him maintained a high degree of excellence in the falcons they caught and educated for a select class of European sportsmen. With the last Mollen, falconry of the Dutch School died almost completely.

Of other well-known experts of Dutch origin we recall John Daims (in Lord Orford's service), John Bekker, his two sons, and John Pells.

In 1864 the famous Old Hawking Club was founded, by E. T. Newcome, to fly hawks on Salisbury Plain. It consisted usually of twelve ordinary and four or five honorary members. This club had the services of five or six professional falconers, several of them noted experts. The last secretary of the club, in existence until 1926, was the well-known English falconer, Captain G. Blaine. In 1927, members of the Old Hawking Club founded the present British Falconers' Club, whose president is (1939) General the Hon. Sir Malik Mohammed Umar Hayat Khan; the vice-presidents are Captains Blaine and Knight. The club publishes a very useful periodical, *The Falconer*, whose efficient editor is Mr. T. A. M. Jack.

In 1865 French falconers founded the Club de Champagne, which was in existence until the year 1870. In 1880 devotees of French falconry met once more, holding meets in the plains of Chalons-sur-Marne. Of these members the best known was M.

Bellvalette, who published his *Traité d'Aoutourserie* in 1887. Today (1939) there are but few active falconers in France. These, however, include M. A. Boyer of Negron, Noël of Imbernais-Eure, and M. de Rabastens of Earn, who own and fly excellent falcons and hawks.

There are few devotees of falconry in Italy,¹ once the home of that noblest of arts.

So far as known, only one man practiced falconry during the nineteenth century in Germany. He was Baron Christoph von Biedermann, who kept a stud of twenty birds, including three Arctic falcons. Not until after 1918 did men with a common love of falconry come together in the Fatherland. They founded, at Leipzig in 1923, the Deutscher Falkenorden. One of them, Dr. Jungklaus, tried to publish a periodical in the interest of the sport, but after two numbers had been issued it was discontinued, owing to lack of contributions.

In later years, however, it became possible to take up this work once more; and the Deutscher Falkenorden assumed the task of exploiting falconry — aspirations that still (1939) hold good. It strives not only to give new life to the noblest of arts, but it also studies the life habits of birds of prey and takes steps to preserve them. The following laws of the Order are in force: "The German Order of Falconers will kill no falcon. It will protect those birds of prey that need protection, including even goshawks and sparrow

¹ Falconry has been sporadically practiced in most of the countries of Europe during the twentieth century, albeit, in some of them, so infrequently as hardly to be worth mentioning. For example, although the devotees of the art in Italy can be counted on the fingers of one hand, it may be said that Prince Pietro Dentice de Frasso of Brindisi maintains a stud of falcons and that quite recently (1939) the King and Queen of Italy were entertained (on a visit to a neighboring country) at a falconry meet. In America there are (estimated) a hundred falconers of various ranks, several private clubs, and other signs, especially in the schools and universities, of a new birth for this interesting sport.

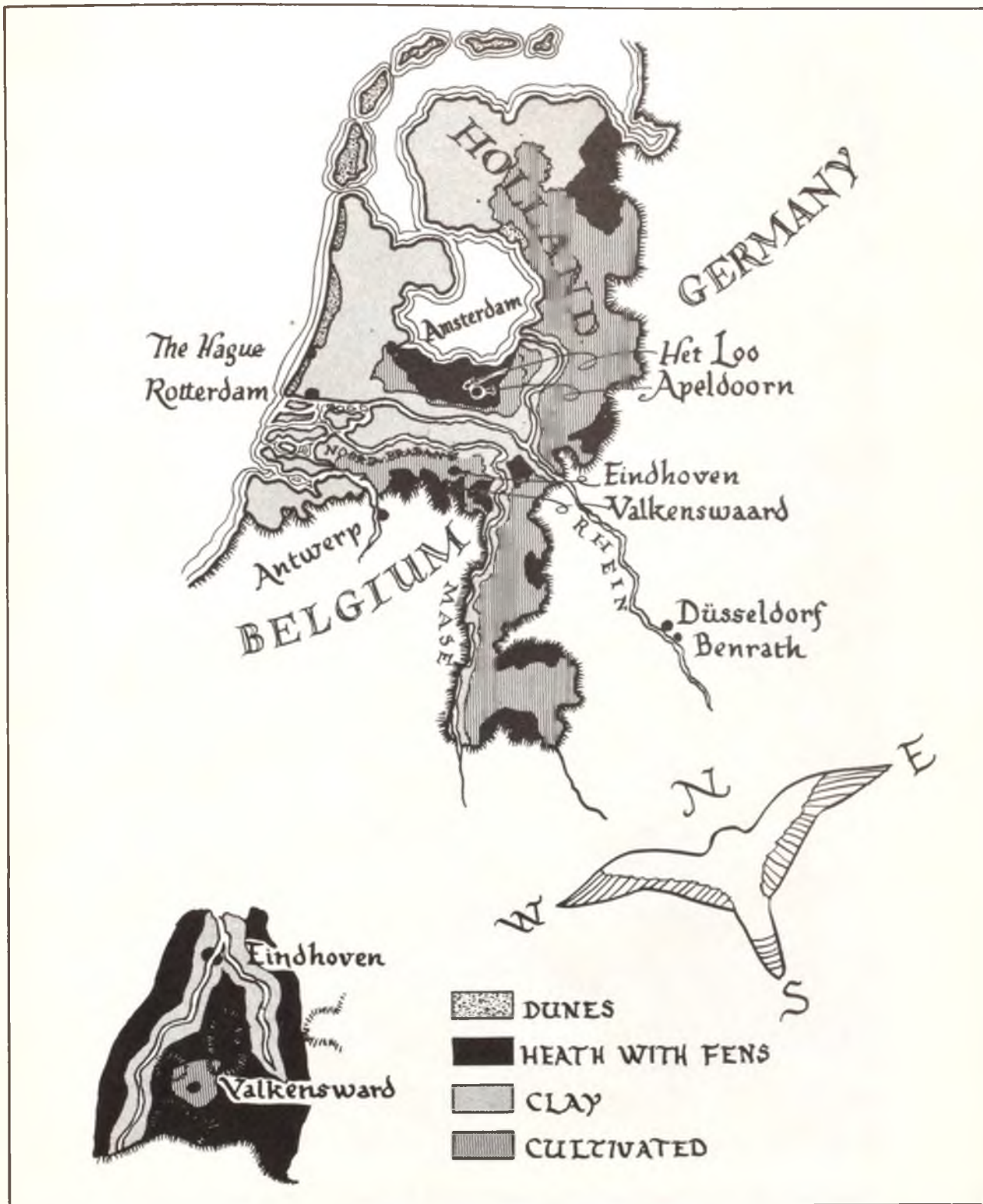

PLATE 146.—Map of Valkenswaard and vicinity. From drawing by J. W. M. van der Wall.

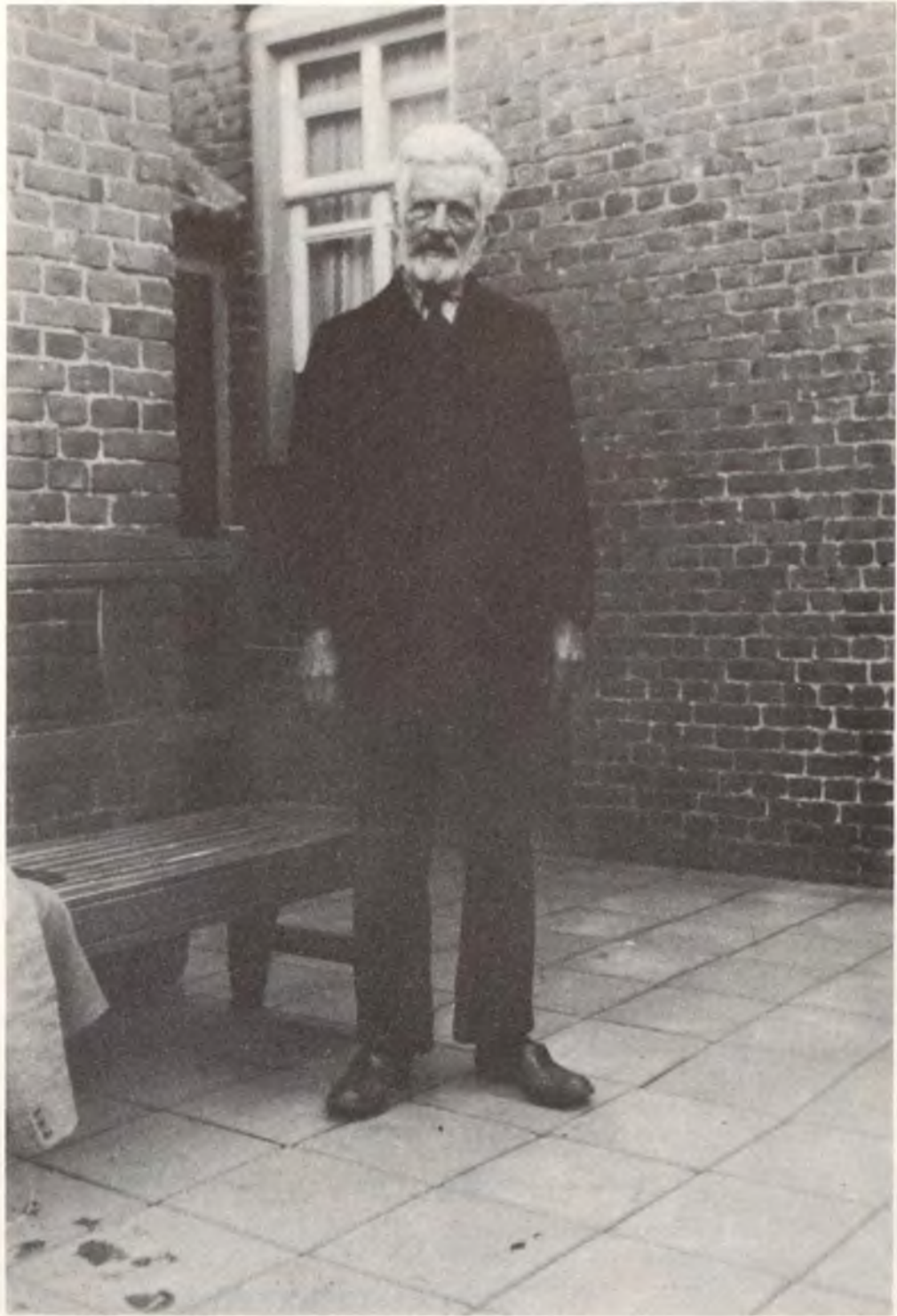

PLATE 147.—Karl Mollen (d. January 1, 1936) behind his house in Valkenswaard, Holland. Photograph taken by J. W. M. van der Wall of Wasenaar (in August 1935), by whose courtesy it is here reproduced.



PLATE 148.—A favorite falcon of the Landgrave of Hesse-Cassel (1773). (Courtesy of Dr. Walter Schlüter.)



PLATE 149.—Falconers Fleming of Barochan, Anderson, and Harvey. From an old print. (Courtesy of Frank T. Sabin and J. N. McWilliam.)



PLATE 150.—Transport for falcons and their equipment, Reichsfalkenhof, Germany.
(Photo by Fischer.)

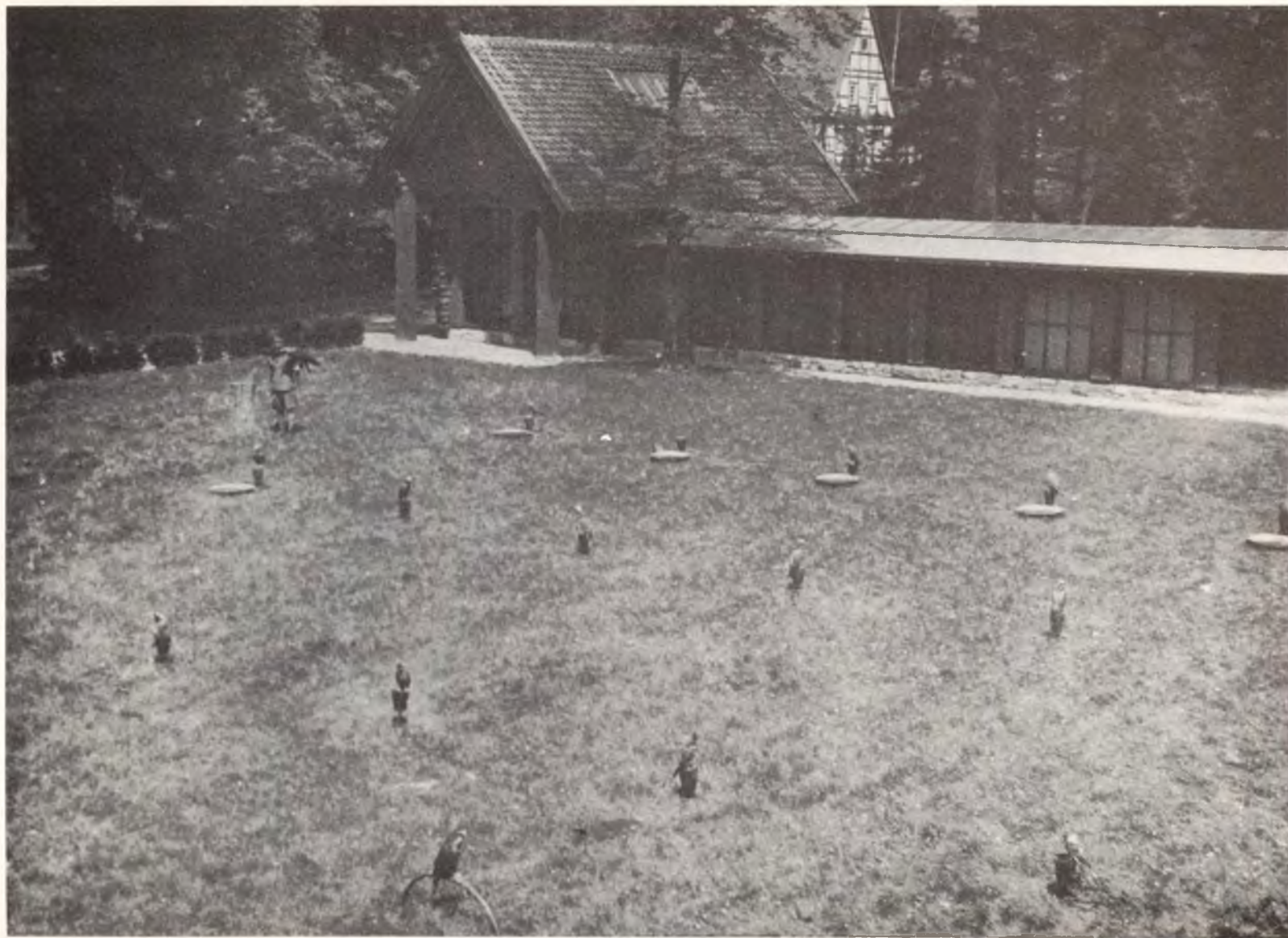

PLATE 151.—Weathering space for falcons at hack, Reichsfalkenhof, Germany. (Photo by Fischer.)

hawks when and where they are not too numerous. The Falconer's Order cultivates and encourages the ancient and honorable art of falconry. We hunt, not for a prize, but for the amenities of the chase."

In its first years the Deutscher Falkenorden had to overcome many handicaps. The lack of experienced falconers made the work especially difficult. In this respect the Order owes much to the Old Hawking Club and the British Falconers' Club. The former, for example, was so kind as to invite the present Master (President) of the Falkenorden to England, and to take part in falconry meets in Scotland.

In 1932, Renz Waller accepted the office of Master of the Order, and it is to him that the club chiefly owes its present development. In 1933 he was able to win the interest and patronage of the Reichsjägermeister, General Field-Marshal Hermann Göring, for Falconry and the Deutscher Falkenorden. During the following year a State Falcon Center (Der Reichsfalkenhof) was built in Riddagshausen in Brunswick, after plans by Renz Waller. Today (1939) the Reichsfalkenhof possesses an eagle and a large number of falcons, especially sakers, goshawks, and sparrow hawks, who are served by a number of professional falconers. Besides the State Falcon Center the German Army possesses three falcon studs, that of the Ortelsburger Jäger, founded in 1926, and those of the Kolberg and Goslar Jäger.

The members of the Deutscher Falkenorden meet once annually, for eight days. There are today forty to fifty practicing members.

The chief German hunting species is the hawk; and the Deutscher Falkenorden possesses a goodly number of well-trained birds. In 1937 for the first time, it was possible for President Waller to capture a wild heron. He is fortunate in owning the famous Medusa, now in her twelfth season.

Apart from falconry, the Deutscher Fal-

kenorden is concerned also with the protection of all birds of prey, and it has been able to secure by law complete protection of passage hawks, eagles, and other birds of prey, with the exception of the marsh harrier, the goshawk, and the sparrow hawk. These aims are to be found in the organ *Deutscher Falkenorden*, which since the International Falconry Exhibition of 1937 has been enlarged.

The falconry of former days is also not forgotten, and works of foreign falconers and experts are welcomed.

Co-operation with outside clubs and falconers was noted in the International Falconry Exhibition held at Düsseldorf in 1937, where the British Falconers' Club contributed greatly to its success. For these efforts that club was awarded the silver medal of the International Hunting Exhibition. In addition to England, France, Italy, Egypt, Japan, Jugoslavia, and Arabia exhibited.

For 1940 the Deutscher Falkenorden has planned an International Meeting for Falconers, together with an International Falconry Exhibition in Munich, to promote the co-operation of falconers of all lands.

Although until recently there have been no regularly constituted associations of falconers in America, yet in various schools and universities groups of students and others have met from time to time and in a limited fashion practiced the noble art. There are in this scattered fashion about one hundred persons interested in falconry, of whom the majority possess one or more hunting birds. The most influential and the most practiced of these is Captain R. Luff Meredith of Boonton, New Jersey, who owns and has flown gerfalcons, peregrines, and other hunters for many years.

Even in Australasia a few enthusiasts practice the noble art. Persia, India, Japan, China, and other Oriental countries have for ages engaged extensively in falconry, both as a sport and as a commercial enterprise; indeed through mercantile and missionary enterprises

(which included the Crusades) Occidental peoples received many an impulse toward, and many a hint about, this aristocratic and widespread amusement. So we may say, "Long live falconry."

The translators have taken the liberty of adding a few observations and illustrations to Dr. Schlüter's all-too-modest chapter. Of course, as every informed falconer knows, the subject could be indefinitely extended.

Prince Nicholas Galitzine says (*Illustrated Sporting and Dramatic News*, April 21, 1936) of the medieval Moscow sporting estates that they were long of interest from a national point of view. The chief of them was the Semenovski Pleasure Yard—the falconry center of the Tzars. This was a miniature town outside Moscow. Its community was a privileged class that lived a completely feudal existence until Peter the Great began curtailing their liberties. The sporting birds of prey were supplied to them by levies on trappers all over Russia. The number of birds used can be judged by the fact that trappers from the Dvina region alone were in the seventeenth century obliged to furnish over two hundred birds per annum.

Under the caption (translated), "Hunting with the Falcon—A Medieval Sport Revived in Modern Asia," the *Corriere Oceanico* prints a notice of falconry, part of which (freely translated) is as follows: "Among the nomads of Chinese Turkestan and Soviet Central Asia, on the hills of the elevated Pamir Plateau, in India at the courts of the Maharajas, who reign in the regions about the Himalayas, and on the central high plateau of Hindustan, as well as in the Syrian desert, even in China and Mongolia (on the mountain where runs the Great Wall) the ancient and medieval sport of hawking is still practiced."

Who does not remember Tranquillo Cremona's famous picture, "Il falconiere"? In

Asia even noble falconers are infinitely less attractive than Cremona's sentimental hunter; but the former have the advantage of being able to use for hunting, eagles *and* falcons, the golden-headed eagle in particular.

The training of hunting eagles—the best of which are, in Asia, worth from three to ten horses—takes much more time and is far more difficult than the education of falcons; but the results of the chase are better in the case of eagles because it appears almost impossible to accustom falcons not to mangle or eat their prey.

It is not necessary to go to Turkestan to assist at a hunt with falcons. The Arabs of Syria catch and train excellent hunting falcons, who build their nests among the ruins of the old Franconian castles on the hills of the Alatau Mountains in Asiatic Russia and on the high hills of Lebanon.

The King of England, during his last trip to India, attended falcon hunts staged by the Maharaja of Puttiala and the Nizam of Hyderabad, each of whom possesses hundreds of falcons under the care of a large number of servants employed in capturing, feeding, and training them, and eagles for exciting hunting scenes on land and water.

Commenting on the same subject, the *New York Herald* (April 25, 1937) correctly tells us that from above the snow-capped peaks of the Tian Shan Mountains (on the Soviet Border of Western China) a trained golden eagle may, during a hunting expedition, descend upon a white fox, bringing instant death to this valuable quarry in one fierce swoop. In another moment the eagle will carry the fox to the hunter. Again, the same eagle, the largest bird trained for falconry, is able with its powerful beak and talons to capture antelopes. One of the illustrations in the *Herald* represents a Kazakh farmer enjoying the 2,000-year-old sport, holding his eagle on his protected right wrist (European custom

calls for the left hand). Over the eagle's head the hunter has slipped a hood, which is kept in place until a quarry is flushed.

Falconry in California is partly described and illustrated in *The Coast* (January 1938). F. T. Barron and Homer Snow, of Oakland, California, the latter an expert naturalist, found a peregrine falcon's eyrie on a slope of Mount Diablo in 1936. The nest contained three fledglings and the tiercel. The birds were inaccessible by ordinary efforts, and Barron had to lower Snow two hundred feet over a ledge, by rope, to capture the birds.

Two of the falcons were sent to be trained by Henri Croesing of Oroville, who had learned many tricks of the trade from his father, a falconer in France.

As part of the revival in America of falconry, as well as of interest in studying the career of the Emperor Frederick II, is a recent exhibit of books, manuscripts (in most languages), photostats, drawings, and falconers' equipment generally that opened in the Redpath Library of McGill University, Montreal, Canada, on February 1, 1939. That collection² is probably the largest and

most varied of its kind in North America, including as it does nearly all the rarer monographs on the subjects mentioned. We are informed by Margaret Hibbard, Librarian of the Zoölogical Department of the Library, that the collection of "Hawk's Furniture" was a striking feature of the exhibit. It consisted largely of falcon's hoods, plain and ornamented (Dutch, East Indian, German, English, and homemade varieties), not to mention samples of bells, jesses, leash, lure, falconer's purse and gauntlet, hunting knife, and other paraphernalia used by the "complete" falconer.

A successful attempt to depict the stoop of a falcon in pursuit of quarry took the shape of a mounted peregrine that was artistically posed by J. D. Cleghorn and others. This arrangement also showed an Elizabethan falconer holding a lure to attract the free-flying falcon.

Doubtless this exhibition, attended by visitors from all over Canada and the United States, will further stimulate the growing desire in both countries to learn more about an ancient and highly specialized art.

² Donated by the senior translator.



PLATE 152.—Rare books and pictures at the International Exhibition of the British Falconers' Club at Düsseldorf, 1936. (Courtesy of the Directorate.)



PLATE 153.—Portion of Falconry Exhibit, McGill University, Montreal, 1939. (Courtesy of the Director of the Libraries.)



PLATE 153a.—A portion of the Falconry Exhibit at McGill University, Montreal, Canada, March 1939. (Courtesy of the Director of the Libraries.)



PLATE 154.—Coins and medals depicting birds of the chase and falconry scenes. No. 10 (X) is a coin struck by Frederick II showing a falcon on the fist. From the Collection of Hugh D. Knight.



PLATE 155.—Medals depicting falconry scenes. From the Collection of Hugh D. Knight.



PLATE 156.—Coins and medals depicting falcons and falconry.
From the Collection of Hugh D. Knight.



PLATE 157.—Coins and medals depicting falcons and falconry.
From the Collection of Hugh D. Knight.



PLATE 158.—Coins and medals depicting falcons and falconry.
From the Collection of Hugh D. Knight.

COINS AND MEDALS DEPICTING FALCONS AND FALCONRY

From the Collection of HUGH D. KNIGHT

FROM the earliest times to the present it has been a comparatively common practice to strike coins, medals, and medallions representing hunting scenes and their components. Of considerable interest are the effigies of falcons and falconry thereon depicted. For example, Fritz Engelmann, who has written the best modern textbook on falconry in any language,¹ furnishes three early examples of these coins, all of them in circulation in 400 B.C. The first represents Alexander the Great

with a falcon on his fist; the second, another coin of the same monarch, shows a hunting hawk; and a third depicts a hawk eagle, presumably employed in the chase.

We are deeply indebted to Mr. Hugh D. Knight for an opportunity to reproduce a fine selection of coins and medals from his collection. They are all extremely interesting and worthy of close inspection, in particular one (No. 10) that portrays the Emperor Frederick II bearing a falcon on his fist. These valuable objects mark the high regard in which the noblest of arts has been held since civilization began.

¹ *Die Raubvögel Europas*, p. 545.

NOTES ON THE SAINT GORGON STATUE FROM VARENCEVILLE, NEAR NANCY

BY GORDON WASHBURN

Director of the Buffalo Fine Arts Academy

 THE STATUE of Saint Gorgon, owned by the Albright Art Gallery, is a wooden figure made, so far as can be determined, of a single piece of fruit wood (perhaps pear), except for its right hand, which is attached at the wrist by a peg and hole device.

The figure is five feet six inches in height and is entirely polychromed over a thin gesso base, typical of Burgundian fifteenth-century statuary.

We know that it is an image of Saint Gorgon on two counts: First, the restorer, who cleaned off several coats of old white paint from the surface of the figure, drew our attention to some lettering on the collar, which was read by means of an ultraviolet-ray machine. It reads, "St. Gorgon." Second, the dealer who sold it to us discovered (independently of this knowledge, i.e., without being aware of it) that the statue originally stood in the village church of Varengeville, near Nancy, France. The church was dedicated to Saint Gorgon. There is no question of doubting him, since we have signed documents from the village priest as well as from antiquaries who handled it before our dealer purchased it.

Our Saint Gorgon, according to Professor C. Morey of Princeton University, "is probably that Gorgonius martyred in Rome whose body was found on the Appian Way and transferred to Tours in 847 A.D. He is celebrated in Tours on March 11th."

A good account of the Saint's life has not yet been made available to us, but it is an example of a young, gay blade who decides to give up court life for the sake of the Church. Certainly the story is clear enough from this statue. He is dressed in fashionable court clothes and holds his falcon on his left wrist. Balancing this, in the other hand, is a missal or prayerbook, and the whole figure suggests that he is shown at a moment of indecision, choosing between the world and the spirit.

He wears long red hose and broad-toed black shoes, naturalistically counterbalanced one behind the other on a wooden pedestal, which is polychromed in imitation of marble. He is attired in a golden tunic and wears over his right shoulder a mantle, which is separated by the arm holding the missal and falls in heavy folds of two sections to a point below the knees. The mantle is gilded, like the tunic, to suggest cloth of gold, and its deep lapis-lazuli blue lining is stenciled with two floral motifs (rose and pomegranate) to suggest brocade. The high-necked tunic, with ruffle at throat, is corded at the waist and falls in heavy, rolled pleats, which are terminated at the hem by two bands, as if to suggest an appliqué finish to the skirt. The sleeves are tucked and puffed on the upper arm. His hair is brown and his face is very naturally tinted with flesh tones.

The statue is in remarkable condition, owing to its preservative coat of white paint, now

removed. Two burns, probably from altar candles, are visible, one still crudely repaired as when found.

Our only method of dating this carving, so far, has been by the style of the costume. We arrive, thus, at the conclusion that the figure was made at the turn of the century, some

time between 1475 and 1525. Different scholars have given different dates, but all within those fifty years.

The statue is now enclosed in a glass case which is difficult to remove. For this reason it has not been possible to measure the exact size of the falcon.

A SHORT ACCOUNT OF THE HOHENSTAUFEN AND NORMAN ANCESTORS OF FREDERICK II AND OF HIS DESCENDANTS

IT IS NOT the purpose of this sketch to furnish anything like a history of the German Hohenstaufens or of the Norman d'Hautevilles. It is felt, however, that to those who are engaged in a study of the great work of Frederick II on falconry it may be of interest to have at hand a few references to the main events of his life, as well as some clues to his ancestors and his early surroundings.

Frederick, through his father, the Emperor Henry VI, belonged to the German House of Hohenstaufen,¹ a family which, through character and ability, as well as through marriage, had risen in two generations from a mere countship under Frederick of Buren to imperial dignity under Conrad III.

In general it may be said of the age of the Hohenstaufens in Germany that it represents one of the most interesting periods of medieval history. Though the times were far from peaceful and frequently characterized by acts of extreme cruelty, it was also a period of profound religious fervor and spirituality that brought forth acts of deep devotion and self-sacrifice. Along with a curiously artificial code of morals and knightly behavior there was kept alive a gay enjoyment of the material life and an ideal of manliness, courtesy, and generosity. Women were held in high esteem and played important and courageous roles in the life of the times. It was the age of the Minnesinger, an age when flourished the arts and crafts, poetry, and song.

¹ Name derived from a castle near Lorsch in Swabia built by Frederick, Count of Staufen.

NOTES ON THE GENEALOGY

CHART A. THE HOHENSTAUFENS

(1). *The Salic or Franconian Emperors* succeeded the Saxon line that failed at the death of Henry II. They were four in number:

- a) *Conrad II* (990–1039); Emperor, 1024–1039.
- b) *Henry III*, born 1017; created Duke of Bavaria and Swabia by his father. Emperor, 1039–1056.
- c) *Henry IV*, born 1050; Emperor, 1056–1106. This is the Henry who did penance at Canossa before Gregory VII.
- d) *Henry V*, born 1081; Emperor, 1106–1125. Died without issue. It is interesting to note, however, that his wife Matilda was that daughter of Henry I of England (known as the Empress Maude) who, upon becoming a widow, married Geoffrey Plantagenet, Count of Anjou. Their son became Henry II of England (1133–1189), two of whose daughters appear later in our genealogy. One, a second Matilda, married Henry the Lion, Duke of Saxony and Bavaria (see 11). A second, Joanna, was the wife of William II (the Good) of Sicily. A granddaughter of Henry II, Isabella, daughter of John, became Frederick II's third wife.

(2). *Frederick, Count of Staufen* (d. 1105), son of Frederick of Buren (d. 1094), married Agnes, daughter of Henry IV, who conferred upon him his Dukedom of Swabia.



E. Pfadtisch

PLATE 159.—Frederick II of Hohenstaufen. Redrawn from a seventeenth-century Italian print of unknown origin, shown by the British Falconers' Club at the International Falconry Exhibit at Berlin, 1938. It is probable that the original design was taken from the bust on the Capua gateway.



PLATE 160.—Crown of Constance of Aragon, first wife of Frederick II, now in the Chapel of the Treasury in the Cathedral at Palermo (thirteenth century).



PLATE 161.—Tomb of the Empress Constance of Sicily, wife of Henry VI and mother of Frederick II. This is one of two tombs brought by Frederick from the Cathedral of Cefalù. The second is that of Constance's father, King Roger II.



PLATE 162.—The Emperor Frederick II enthroned. From the Exultet Rolls of Salerno. To be compared with other portraits of the Emperor, especially Plate 3, page xxxi. See also text on page 504.

(3). It was the wish of Henry V that his nephew, *Frederick, Duke of Swabia*, should succeed him as Emperor. In spite of the influence of his Welfic wife, Judith, daughter of Henry the Black, Frederick failed of election and was superseded by Lothair of Saxony.

(4). *Lothair*, Count of Supplinburg, had been created Duke of Saxony by Henry V when Magnus, the last of the Billing family of Saxon Dukes, died. Magnus left his large personal estates to the wife of Henry the Black. These estates were reunited with the Saxon Dukedom when Henry the Proud married Lothair's daughter Gertrude.

(5). *Henry the Black* was the head of the Bavarian Welfs (or Guelfs), whose blood flows in the veins of the present English royal family. They had the following origin: Alberto Azzo d'Este married Kunitza, sister of Welf III, Duke of Carinthia. Their son, Welf IV, inherited his uncle's title. He married the daughter of the Duke of Bavaria and upon the Duke's death was granted that Dukedom also by Henry IV.

(6). When Lothair II died, the Dukedom passed to *Henry the Proud*, his son-in-law, who had inherited his mother's estate and his father's Dukedom of Bavaria. He thus became one of the most influential princes in Germany.

(7). *Conrad III* (Duke of Franconia), born 1093. He joined his brother Frederick of Swabia in opposing Lothair II, was set up as anti-king, and was crowned at Milan in 1127. He was excommunicated by Honorius II, submitted in 1135, and was elected Emperor in 1138. He deprived Henry the Proud of his Duchies; took part in the Second Crusade, upon which his nephew Frederick accompanied him. He died (1152) leaving only an infant son, having designated Frederick Barbarossa as his successor.

(8). *Frederick I* (Barbarossa), born 1123; died 1190. Our author's grandfather was by birth both Welf and Waiblingen

(Guelf and Ghibelline). His mother, Judith, a sister of Henry the Proud, Duke of Bavaria (see 5), was descended from Guelf d'Este and the Welf Dukes of Carinthia and Bavaria. The name Waiblingen given to the followers of the Hohenstaufen came from the castle of that name, a favorite residence of Conrad III.

The Hohenstaufens could claim descent on the distaff side from the Salic Emperors, all men of courage and intelligence, through Agnes, sister of Henry V (the last of that line) and wife of Frederick, Count of Staufen.

Frederick I, who became Emperor in 1152, married Beatrice, daughter of the Count of Burgundy (Franche-Comté), by whom he had three sons: Frederick (see Chart A), who accompanied his father to the Holy Land upon the Third Crusade, where he died shortly before his father, in 1190; Henry, who became Emperor; and Philip, Duke of Tuscany.

The first years of Barbarossa's reign were spent in pacifying Germany. In 1155 he went to Rome, where he was crowned in St. Peter's. Returning to Germany, he restored the Duchy of Bavaria to Henry the Lion (1156). The following years were turbulent ones in northern Italy, and were marked by the formation of the Lombard League. Frederick's defeat at Legnano (1176) was followed by the Peace of Venice (1177) and the Peace of Constance (1183). By these two pacts he brought peace to Italy. In 1184, at the Diet of Mainz, a great celebration was held to mark the achievement of peace and prosperity in the Empire. His death while in Cilicia (1190) on the Third Crusade was a blow to the Empire.

Frederick Barbarossa is described as a handsome man of commanding figure and of a noble nature and, though tenacious of purpose and at times very severe, was a passionate lover of justice who knew when to submit with good grace to the inevitable. After a

period of struggle and warfare he brought peace to the Empire and upon his last journey to Italy came without an army and was welcomed with cheers and rejoicing as he went from city to city up the Valley of the Po. In 1186 he confirmed the peace he had made with William II of Sicily, by the marriage of his second son, Henry, to Constance, William's aunt and heiress. He took part in the Third Crusade, from which he never returned, having been drowned (1190) when swimming in the river Salef, before reaching Jerusalem. After his death the legend, immortalized in Ruckert's beautiful ballad, arose in Germany that the great Barbarossa was not dead but slept beneath his castle on the mountain of Kyffhauser and would some day waken to restore Germany to power and prosperity and to bring rejoicing to his people.

(9). *Henry VI*, born 1165. Of Frederick I's son the account is less attractive. He was, in fact, known as Henry the Cruel, from the relentless harshness with which he pursued all who in any way opposed him. He was crowned King at Aix-la-Chapelle in 1169, and King of Italy at Milan in 1186 on the occasion of his marriage with Constance of Sicily (see Chart B). He became regent during his father's absence on the Crusade (1188) and was elected Emperor on his father's death. When William II died (1189), Henry made peace with Henry the Lion in order to be free to attack Tancred (see L, p. 487), who had seized the throne of Sicily. However, another Welf rebellion kept him in Germany until 1194, when peace in Germany and the death of Tancred opened the way for his claim to Sicily. In December 1194 he was crowned at Palermo. Here he treated the Norman barons and other supporters of Tancred with extreme ruthlessness and sent Tancred's widow and small child, William, to prison in Germany, where report has it they were blinded. Returning to Germany he tried to have the imperial dignity made hereditary

in the Hohenstaufen family, but had to be content with seeing his two-year-old son, Frederick, crowned king (1196). Late in 1196 Henry VI started out for the Fourth Crusade, but reached Messina only to die of fever.

It is probably just as well that his reign was short and that he did not live to influence his son, our Frederick. Yet this very Henry was a poet of no small merit, as his songs in the *Manessische Codex* at Heidelberg bear witness. He tells us that "love is for him of more value than the crown which awaits him. It is, however, extraordinarily revealing that his thoughts turn ceaselessly to this Crown, Kingdom and Sovereignty."¹

(10). *Philip of Swabia*, Duke of Tuscany, died 1208. At the death of Henry VI, Philip tried to hold the throne of Germany for his nephew Frederick; but in March 1196, in order to keep the succession in the House of Hohenstaufen, he was crowned German King at Mainz. At the same time Otto of Bavaria was made King at Aix-la-Chapelle. Neither became Emperor until after Philip's murder in 1208.

(11). *Otto IV*, died 1218. Son of Henry the Lion and of Matilda, daughter of Henry II (Plantagenet). Upon the death of his rival, Philip, Otto bargained with the Pope (Innocent III) to be made Emperor and was re-elected at Speyer and crowned in Rome. He failed to keep his promises to the Pope concerning the domains of the Countess Matilda and was excommunicated in 1210. The German nobles then revolted and, as Emperor, elected Frederick of Sicily (1212). Defeated at Bovines in 1214, Otto lived in retirement until his death in 1218.

CHART B. THE NORMANS

On his mother's side Frederick II was descended from one of the most interesting,

¹ Hans Naumann, *Die Minnesinger und Ihr Maler*, Insel Bucherei, No. 450.

though less exalted, families of the Middle Ages. At the time that Normandy was sending a line of adventurous nobles across the English Channel to conquer and settle an island in the North Sea, another stream of emigration flowed south and east, mainly under the impulse of the Crusades, but lured also by a love of adventure and hope of gain. Groups of these Norman knights had lingered in southern Italy (then a rallying point for Crusaders) sometimes helping, sometimes hindering the Lombard barons who were encroaching upon and dispossessing the representatives of the Eastern Empire and of Saracenic rule in southern Italy.

(A) and (B).² The Normans aforesaid had already founded the stronghold of Aversa (1030) when there landed at Naples three sons of a poor Norman gentleman of Coutances, *Tancred d'Hauteville*, namely, *William Bras-de-Fer*, *Drogo*, and *Humphrey*, who threw in their lot with their fellow countrymen. These three (and two more) were all sons of Tancred's first marriage. By his second wife he was to have seven others, five of whom followed their half-brothers to Italy.

William Bras-de-Fer, aided by *Drogo* and *Humphrey*, soon made himself of consequence in the south and was created Count of Apulia, a title which passed, upon his death in 1047, to *Drogo*. At this time the Emperor, *Henry III*, presented southern Italy to the Normans provided they could hold it against the Eastern Emperors. At the same time there ventured south a fourth of Tancred's sons.

(C). Of *Robert Guiscard* we are given the following description in the *Alexiad* of *Anna Comnena*, the Byzantine Princess: This Robert was of Norman origin and of an obscure family; he united a marvelous astuteness with immense ambition, and his bodily

² Capital letters (A), (B), etc., in parentheses, refer to individuals shown on Chart B.

strength was prodigious. His whole desire was to attain to the wealth and power of the greatest living men; he was extremely tenacious of these designs and most wise in finding means to attain his ends. In stature he was taller than the tallest; of a ruddy hue and fair-haired; he was broad-shouldered, and his eyes sparkled with fire; the perfect proportion of all his limbs made him a model of beauty from head to heel, as I have often heard people tell. Homer says of Achilles that those who heard his voice seemed to hear the thundering shout of a great multitude, but it used to be said of this man that his battle cry could turn back tens of thousands. Such a man, one in such a position, of such a nature, and of such spirit, naturally hated the idea of service, and would not be subject to any man; for such are those natures which are born too great for their surroundings. Being, therefore, so constituted and utterly incapable of obeying, Robert set out from Normandy with five horsemen and thirty men on foot, and came and lived in the fastnesses and caverns and mountains of Lombardy [meaning Calabria then largely under the sway of Lombard nobles], supporting himself by robbery and plundering travelers, thus procuring horses, necessaries, and arms. So the beginning of his life was filled with bloodshed and murder.

Drogo was assassinated in 1048 at *Montolio*, and Robert lent his assistance to *Humphrey*, now, in his turn, Count of Apulia.

(D). Various authors mention three more brothers; but the accounts are confusing, and it is not entirely clear whether or not *Richard*, Prince of Capua, *William*, Duke of Salerno, and *Geoffrey* are all three to be counted as d'Hautevilles.

When *Humphrey* died (1057), *Robert* became leader of the Normans and in 1059 was created Duke of Apulia and Calabria by *Nicholas II* (at the instigation of *Hildebrand*). This act of the Pope won Robert's support

CHART B

DESCENDANTS OF TANCRED D'HAUTEVILLE, NORMAN ANCESTOR OF FREDERICK II OF HOHENSTAUFEN

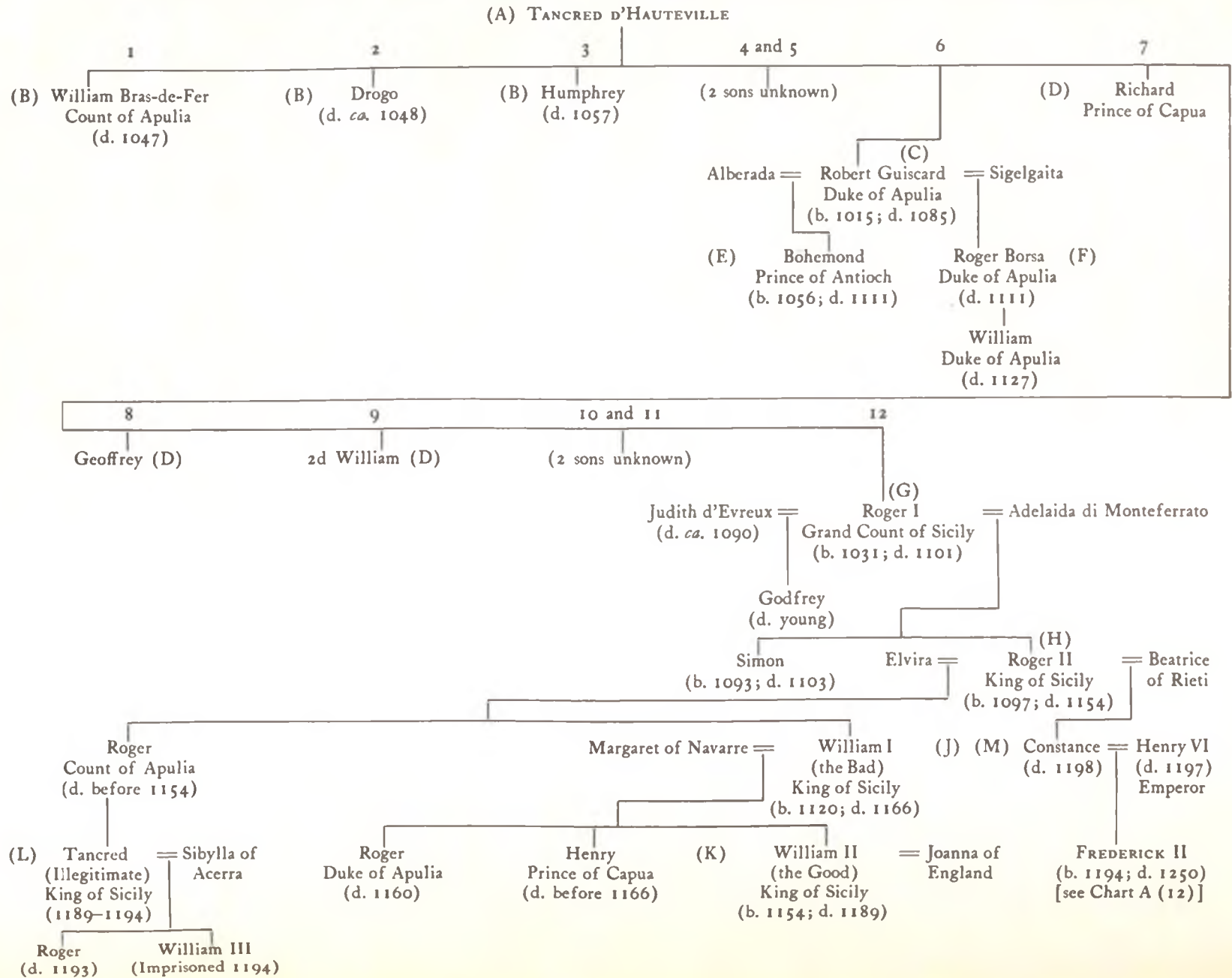

for the Papacy. In return he swore fealty to the Pope for his Dukedom and assisted Gregory VII (Hildebrand) against the Emperors. Robert had now gained control of all southern Italy and, having set his brother Roger the task of subduing Sicily (see G), he himself formed a fleet of more than one hundred warships, set out eastward, and captured Corfu and Durazzo from the Venetians (1082) and the Byzantines. In 1084 Robert left his son Bohemond to carry on the fight in Dalmatia and hurried to Rome to secure Gregory VII from attack by Henry IV. To his everlasting shame he allowed his troops to sack Rome. He then rejoined his fleet in 1085 and had undertaken the conquest of Cephalonia when he was stricken by plague (or poison) and died in July of that year.

(E). *Bohemond* (Robert Guiscard's elder son) had an adventurous life. He became Lord of Taranto, joined the First Crusade in 1097, and founded the principality of Antioch. He was captured by the Turks and held prisoner for four years (1100-1103), was defeated by the Moslems in 1104, and returned to Taranto; he set out again to fight Alexius, Emperor of Constantinople, was defeated in 1108, and, returning to Italy, died there in 1111.

(F). *Roger Borsa* (Robert's second son) usurped the title of Duke of Calabria and Apulia from his half-brother Bohemond, and ruled until his death in 1111. The Dukedom passed to his son, William, who, though not strong in mind or body, ruled until 1127.

(G). *Count Roger* (1031-1101), the youngest son of Tancred d'Hauteville, who adventured to Italy in 1057 when his brother Robert came into control of the Dukedom, had been assigned by the latter the work of conquering Sicily from the Saracens. This task he carried on with wisdom and courage from 1062 until 1091; and he finally conquered the entire island. He was greatly aided in this task by his first wife, Judith (or

Erimburga) of Evreux. The chronicler Galfridus thus characterizes the four months' siege of Troina by the Saracens: "such was their want of clothing that the count and countess had only one cloak between them, which they wore alternately, as each had most need of it. The young countess, without allowing a murmur to escape her, quenched her thirst with dirty water and appeased her hunger with tears." Roger, unable longer to watch her sufferings, made a sortie at the head of his men and "during this day the single hand of Roger, with the help of God, did such execution, that the corpses of the enemy lay around him on every side, like the branches of trees in a thick forest when strewn by a tempest." They were both buried in the Cathedral of Mileto, Count Roger's favorite residence. Earthquakes have completely destroyed the old town, and the ancient sarcophagi in which they were entombed are to be found today in the Museum at Naples. Roger's first wife died about 1090, leaving only one son, who either died young or entered a monastery. Roger married again, this time Adelaida of Monteferrato. They had two sons: the first, Simon, who was eight years of age at his father's death in 1101 and died two years later; and Roger, who succeeded him.

(H). *Roger II* (1097-1154) was a minor at the death of the Grand Count, and Sicily was ruled by Adelaida until 1112 when Roger came of age. She then moved to Palestine, where she married King Baldwin of Jerusalem. Roger initiated his accession by claiming the Dukedom of Calabria and Apulia and, when it was rendered vacant by the death of his (second) cousin William, a display of force induced Honorius II to invest him with the Dukedom. Soon after, having received homage from the barons of Italy, he returned to Sicily and at a Council of State at Palermo in 1130 he assumed the title of "King of Sicily and Italy." He was crowned

by a legate of the Anti-pope, Anacletus. The Lateran Council of 1133 annulled the acts of Anacletus, but in 1139 Roger captured Innocent II in battle and treated him with such reverence that he was rewarded with the titles of King of Sicily, Duke of Apulia, and Prince of Capua.

King Roger then conquered Tripoli. His Admiral, George of Antioch, captured Corfu, Thebes, and Corinth, and attacked Constantinople. Roger spent his last years in Palermo, where he was surrounded by learned Arabians, among them the geographer Idrisi, who wrote under his direction *The Book of Roger, the Delight of Him Who Journeys through the World*, a work which occupied fifteen years. F. Marion Crawford says in *Rulers of the South* that "the great map of the world which Roger caused to be engraved upon a disk of silver weighing between three and four hundred pounds has been fully described [in that work], but it is needless to say that it disappeared in the disturbances of later times. Upon it were engraved 'the seven climates with their regions and townships, their coasts, and their tablelands, their gulfs, seas, springs, and rivers, their inhabited and uninhabited lands, their highroads measured in miles, and the distances by sea from port to port'."⁸

King Roger ruled in conjunction with some sort of parliament and showed great tolerance of his Saracen subjects. The Moslem religion was freely permitted. Greek, Latin, and Arabic were used in public documents. "The King," says Villari, "as apostolic legate, was present at Catholic functions clad in a dalmatic embroidered with golden Cufic characters and bearing the date of the Hegira. In close vicinity were to be seen feudal castles,

⁸ We do not know when this great map was destroyed; but from the frequent references made by Frederick II to the seven climatic zones, one may safely say that it still existed in his lifetime. Cf. also footnote, Book I, chapter xxi, p. 39.

Greek cities, Mohammedan villages, Lombard colonies, streets occupied by Pisans, Genoese and Amalfitans. The sound of bells and the chanting of monks mingled with the voice of the muezzin from his minaret, and in the crowd were seen side by side the Arab cloak, the Moslem turban, the Norman coat of mail, the long Greek tunic, and the short doublet of the Italian."

Saracen workmen and artists found employment on the buildings erected under Roger. To him are due the incomparable Palatine Chapel and the old part of the Royal Palace in Palermo (where King Roger's rooms are still shown), the Church of the Eremiti, the Church of the Martorana, and the Palace of La Favara. In 1129 he had built the great Cathedral of Cefalù, where he prepared his tomb (now at Palermo). When Roger died in 1154 he left one son, William, by his first wife, Elvira, and a daughter, Constance, born posthumously to his second wife, Beatrice of Rieti.

(J). *William I, the Bad* (1120-1166), is said to have been more Moslem than Christian in character and manners. Brought up in the luxury of his father's court, surrounded by his learned Arabians, he displayed none of his father's mental qualities, and was indolent and morose. He left the government of the country to others until the Norman barons revolted, killed all the eunuchs of the palace, and slaughtered the Moslems in the streets; also they seized William in the Council Chamber and held him captive. He was released by desire of the people and, after punishing his opponents with great cruelty (aided by the Saracens whose families had been killed), he shut himself up in his palace, where he lived in apathy and vice until his death in 1166, at the age of forty-six, mourned by the Saracen women, who rushed about the streets clothed in sackcloth and uttering funeral songs and wild laments. William left but one son, the two elder having

predeceased him. He is buried in the Cathedral of Monreale, built by his successor.

(K). *William II, the Good* (1154-1189), was a minor when his father died, and the kingdom was ruled for several years by his mother, Margaret of Navarre, who called to her aid two able men: The first, her relative, Stephen of Perche, whom she made Archbishop of Palermo, soon restored order in the state; but he was extremely unpopular and was forced to leave the country. Margaret's second assistant, the Englishman, Walter of the Mill (Gualterius Offamilius), was at first tutor to the young king, who made him Prime Minister and Archbishop of Palermo. He built for William the wonderful Cathedral (1169) where are buried at least eight of the Royal House of Sicily. Richard of San Germano says: "William was the flower of kings, the crown of princes, the mirror of the citizens, the glory of his nobles, the hope and trust of his friends, and the terror of his enemies," and in his time "there was more security in the thickets of Sicily than in the cities of other kingdoms." William built also the Cathedral of Monreale (one of the glories of Sicily), where he, his father and mother, and his two brothers are buried. William's wife Joanna, daughter of Henry II of England, had no children; and William, wishing to secure the succession to the throne, negotiated the marriage of his aunt Constance (who was about his own age) to Henry, the son of Barbarossa (see 9, p. 482, above).

(L). *Tancred, Count of Lecce* (died 1194), was the illegitimate son of King Roger's eldest son, Roger, Duke of Apulia, who died before 1154. He was a man of fine character and great ability. Many of the Norman barons and the Saracen element, fearing and disliking the idea of a German ruler, led by the Chancellor, Matteo, claimed the throne of Sicily for Tancred and he was crowned at Palermo in 1189. But there was

continual warfare with adherents of Constance⁴ and Henry, and though Tancred was able to extend his power over Sicily and southern Italy, his success was short-lived and he died in 1194, leaving as his heir his second son, William, under the guardianship of his wife, Sibylla, daughter of the Count of Acerra. Their fate is recorded under 9, above.

(M). *Constance* (1154?-1198), Frederick's mother, remains for us a shadowy figure. She was born, it is said, after her father King Roger's death, and was probably brought up in retirement, away from the court of her brother, William the Bad. Although she was removed from a convent to marry Henry, it is not probable that she had taken vows as a nun; but it is intimated that she was a very religious woman whose marriage to a man as harsh as Henry must have been a far from happy event. Upon her husband's death, as heiress of William, she took the reins of government into her own hands. She refused to recognize the authority in Sicily of the German Markwald of Anweiler, the Grand Seneschal of the Empire, and expelled from the island as many as possible of Henry's German followers. She recognized certain rights of the Holy See over Apulia, and had the four-year-old Frederick crowned in the Cathedral at Palermo. Unfortunately, Constance outlived her husband by little over a year. By her will she made Pope Innocent III Regent of Sicily, and the Bishops of Sicily Frederick's personal guardians.

FREDERICK II
(See Chart A)

(12). *Frederick II* (1194-1250), our author, was born in the little town of Jesi near Ancona, to which Constance had retired while her husband Emperor Henry VI was in Palermo punishing the adherents of Tan-

⁴ See (M).

cred and being crowned king. Frederick was chosen King of the Romans by the German nobles at Aix-la-Chapelle in 1196, and crowned King of Sicily in 1198, after the death of his father. When Constance, also, died there arose a three-cornered struggle for the throne among the followers of Markwald (including large numbers of Saracens who had been driven from Palermo by the Christianizing influence of William the Good's reign), the protagonists of Walter of Brienne (a son-in-law of Tancred who was claiming the throne), and Frederick's guardians. The regents took the young king to Messina for safety; and there he remained until peace was established by the death of both Markwald and Walter.

In 1208 Frederick, now fourteen years old, was declared of age by Innocent III, who arranged a marriage for him with Constance, the sister of Peter II of Aragon (see Chart C) and widow of a Hungarian king. She was older than he, of an astute and courageous race, and there is every indication that the marriage was a fortunate one for the young King, whose fortunes were now at a low ebb. Otto IV was ruling in Germany, the allegiance of the Calabrian and Apulian barons was in question, and Sicily had but recently undergone a period of civil strife. However, a rapid change was in sight. Innocent III excommunicated Otto, who had invaded Apulia and was unpopular in Germany, reminded the Germans of Frederick's previous election, and thus asserted the Papal supremacy over the Empire. The Germans invited Frederick to claim his rights; and so, with a handful of followers, he set out for Germany, going first to Rome, where he met Innocent. He was induced to promise that if he became Emperor he would cede Sicily to the Pope as a fief to be held by his, Frederick's, infant son Henry—a promise he soon forgot. He made his way to Mainz, where he was chosen King-Emperor and crowned. In

1215 he was crowned also at Aix-la-Chapelle. Frederick remained in Germany until 1220. In that year he had his son, Henry, elected German King as his successor and made him viceroy under a regency.

The young Emperor now returned to Italy, where he and Constance were crowned at Rome by the new Pope, Honorius III. Upon re-entering Sicily he had again to subdue the unruly nobles. This he accomplished, at the same time bringing about the first of the legislative reforms by which his reign is marked in both Germany and Italy. In 1222, on December 25, Constance died.

Frederick had promised both Innocent and Honorius to join a Crusade, but affairs of state had intervened. He now married Iolanthe (or Yolanda), daughter of John of Brienne, and prepared to accomplish his Crusader's vow and at the same time to claim the Kingdom of Jerusalem in his wife's name; but, on sailing from Brindisi, he was obliged to put back into Otranto, when fever broke out among the troops. The new Pope, Gregory IX, having issued a bull of excommunication against him, Frederick answered with an amazingly forceful manifesto addressed to the "Princes and Peoples," in which he denounced the ambitions of the Church and the corruption of Churchmen in general, a document that was read in public before an enthusiastic audience on the Capitol in Rome. Gregory fled to Perugia and Frederick once more set forth on his Crusade. He accomplished his purpose through a treaty with the Sultan of Egypt whereby he gained peaceful entrance into Palestine and Jerusalem. Here he crowned himself King, as heir of his late wife, Yolanda, who had died in 1227, ten days after the birth of her son Conrad.

It was while on this journey to Egypt and Palestine that Frederick gained his first-hand knowledge of falconry as it was practiced by the Arabs of Syria and other parts of the Near East.



PLATE 163.—Twelfth-century mosaic in the Church of the Martorana at Palermo (built by Roger's admiral, George of Antioch), showing Christ crowning King Roger II.



PLATE 164.—Hunting scene in the chamber of Roger II (twelfth century), Royal Palace, Palermo.



PLATE 165.—Abbey of the Holy Trinity at Venosa (eleventh century). Here are buried four elder brothers of Count Roger of Sicily, William Bras-de-Fer, Drogo, Humphrey, and Robert Guiscard, and also Alberada, wife of Robert.



PLATE 166.—Remains of laurel-crowned stone head found recently at Castel del Monte, probably representing the Emperor's grandfather Frederick Barbarossa. The remarkable technique of its carving is a direct attempt to copy classical workmanship. (*Right*) Damaged bust, probably representing one of Frederick's favorite falconers, found recently (1938) at Castel del Monte.



Returning to Italy (1229), Frederick landed in Apulia to find that Gregory had proclaimed a holy war against him. Aided by his Crusaders (among them many Saracens) he routed the Papal forces, and the Pope was glad to lift the ban and make peace.

Gregory introduced the Inquisition to Rome, causing the people again to turn upon him and drive him out. Twice Frederick II intervened and reseated him. In 1235, when Frederick's son Henry VII joined the Guelf party in Germany, the Lombard cities, and the Pope in a plot to make himself Emperor, Frederick first secured the neutrality of Gregory by joining his forces with those of the papacy and defeated the rebel Romans at Viterbo. He then hastened to Germany, where he soon restored order, bringing about administrative and judicial reforms. Henry was taken prisoner and after a time sent (1235) to Apulia.

Frederick's second son, Conrad, was now elected King in place of Henry and became Regent of Germany. Frederick at this time marched south to Italy and renewed the fight against the Lombard cities; at this the Pope took offense, and placed Frederick under the ban. Frederick appealed for an Imperial Diet, but the Pope instead called a clerical Council. Frederick seized the cardinals and prelates of the Council who had sailed from Genoa for Rome, took them prisoners to Naples, and then proceeded north. He reached Grottaferrata when news came that Gregory IX was dead (1241) at nearly one hundred years of age. The next Pope, Celestine IV, survived his elevation to the throne for only eighteen days. Finally, at Anagni in 1243, Pope Innocent IV was elected. He refused to lift the ban unless Frederick promised to evacuate certain fortresses; but Frederick refused. Innocent then took refuge at Lyons, where he called a Council that declared Frederick deposed. There followed a battle of words: Frederick attacked the greed, arrogance, and

vices of the papacy and clergy; Innocent proclaimed papal supremacy over the Empire. The Pope sent priests with money throughout Sicily and Italy to incite rebellion. Frederick once more took up the work of pacifying the Lombard cities (1247), assisted by his son Enzo and his son-in-law Ezzolino. After some initial success, they were defeated at Parma and Enzo was taken prisoner by the Bolognese. It was at this time that Frederick arrested and (perhaps) blinded his great friend and adviser, Piero della Vigna, accused of treason. The circumstances and the truth of the accusation, as well as of the punishment meted out to him, are still in doubt; but we do know that Piero committed suicide in prison.

Though his campaign in Lombardy had finally taken a favorable turn, Frederick, saddened and disappointed, now went south, perhaps to seek consolation in his falcons afield on the open spaces of the Apulia that he loved. Here he was stricken with fever, and died at Castel Fiorentino, near Lucera, on December 13, 1250.

A poem written by Frederick II, and translated by Dante Gabriel Rossetti is thought by Rossetti to refer to the bondage of the Church and his wish to see her free of papal domination. As it is the only poem of the Emperor's of which we have an English translation, we give it here:

OF HIS LADY IN BONDAGE

For grief I am about to sing,
Even as another would for joy;
Mine eyes which the hot tears destroy
Are scarce enough for sorrowing:
To speak of such a grievous thing
Also my tongue I must employ,
Saying: Woe's me, who am full of woes!
Not while I live shall my sighs cease
For her in whom my heart found peace:
I am become like unto those
That cannot sleep for weariness,
Now I have lost my crimson rose.

And yet I will not call her lost;
 She is not gone out of the earth;
 She is but girded with a girth
 Of hate, that clips her in like frost.
 Thus says she every hour almost:—

“When I was born, ’twas an ill birth!
 O that I never had been born.
 If I am still to fall asleep
 Weeping, and when I wake to weep;
 If he whom I most loathe and scorn
 Is still to have me his, and keep
 Smiling about me night and morn!

“O that I never had been born.
 A woman! a poor, helpless fool,
 Who can but stoop beneath the rule
 Of him she needs must loathe and scorn!
 If ever I feel less forlorn,
 I stand all day in fear and dule,
 Lest he discern it, and with his rough
 Speech mock at me, or with his smile
 So hard you scarce could call it guile:
 No man is there to say ‘Enough.’
 O, but if God waits a long while,
 Death cannot always stand aloof!

“Thou, God the Lord, dost know all this:
 Give me a little comfort then,
 Him who is worst among bad men
 Smite thou for me. Those limbs of his
 Once hidden where the sharp worm is,
 Perhaps I might see hope again,
 Yet for a certain period
 Would I seem like as one that saith
 Strange things for grief, and murmureth
 With smitten palms and hair abroad:
 Still whispering under my held breath,
 ‘Shall I not praise Thy name, O God?’

“Thou, God the Lord, dost know all this:
 It is a very weary thing
 Thus to be always trembling:
 And till the breath of his life cease,
 The hate in him will but increase,
 And with his hate my suffering.
 Each morn I hear his voice bid them
 That watch me, to be faithful spies
 Lest I go forth and see the skies;
 Each night, to each, he saith the same:—
 And in my soul and in mine eyes
 There is a burning heat like flame.”

Thus grieves she now; but she shall wear
 This love of mine, whereof I spoke,
 About her body for a cloak,
 And for a garland in her hair,
 Even yet: because I mean to prove,
 Not to speak only, this my love.

DESCENDANTS OF FREDERICK II

(See Charts A and C)

Upon Frederick's death the power of the Hohenstaufens was broken and the unified state he had attempted to build divided rapidly into its component parts. Tragedy overwhelmed his descendants and, as we shall see, within a few short years this noble and gifted race was practically extinct.

(13). *Henry VII* (1210–1248?), Frederick's eldest son, was crowned King of the Romans at Frankfurt (1220) and was left by his father in Germany under guardians. He married Margaret of Bavaria and for fifteen years was recognized as heir to the Empire. In 1235 he was induced to conspire with the Lombard cities and the Pope to lead a rebellion against his own father. He was defeated, taken prisoner by Frederick, and sent south to live in confinement in Apulia and Calabria for the rest of his life. Tradition has it that he was killed when his horse fell, or was forced by him, over a cliff as he was traveling from the Castel at Nicastro to Martorano.

Along the road all shapes must travel by,
 How swiftly, to my thinking, now doth fare
 The wanderer who built his watchtower there
 Where wind is torn with wind continually!
 Lo! from the world and its dull pain to fly
 Unto such pinnacle did he repair,
 And of her presence was not made aware,
 Whose face, that looks like Peace, is Death's own
 lie.

Alas, Ambition, thou his enemy,
 Who lurest the poor wanderer on his way,
 But never bring'st him where his rest may be,—
 O leave him now, for he is gone astray

Himself out of his very self through thee,

Till now the broken stems his feet betray,
And, caught with boughs before and boughs behind,
Deep in thy tangled wood he sinks entwined.⁵

(14). *Conrad IV* (1227–1254), Frederick's second son, had been crowned King of the Romans, as his father's successor, after Henry's rebellion in 1235, and was acting as Regent in Germany at the time of his father's death. Innocent III hurried from Lyons to

(his son) as the last of the legitimate Hohenstaufens.

(15). *Henry* (1238–1252), Frederick's son by Isabella of England, whom he had married in 1235 and who died⁶ in 1241, acted as Viceroy of Sicily for a few years during his father's lifetime, but he died before Conrad, leaving no heirs.

(16). *Manfred* (1232–1266), *bello e biondo*, an illegitimate son born to Bianca

CHART C

KINGS OF ARAGON AND ARAGONESE DESCENDANTS OF FREDERICK II OF HOHENSTAUFEN

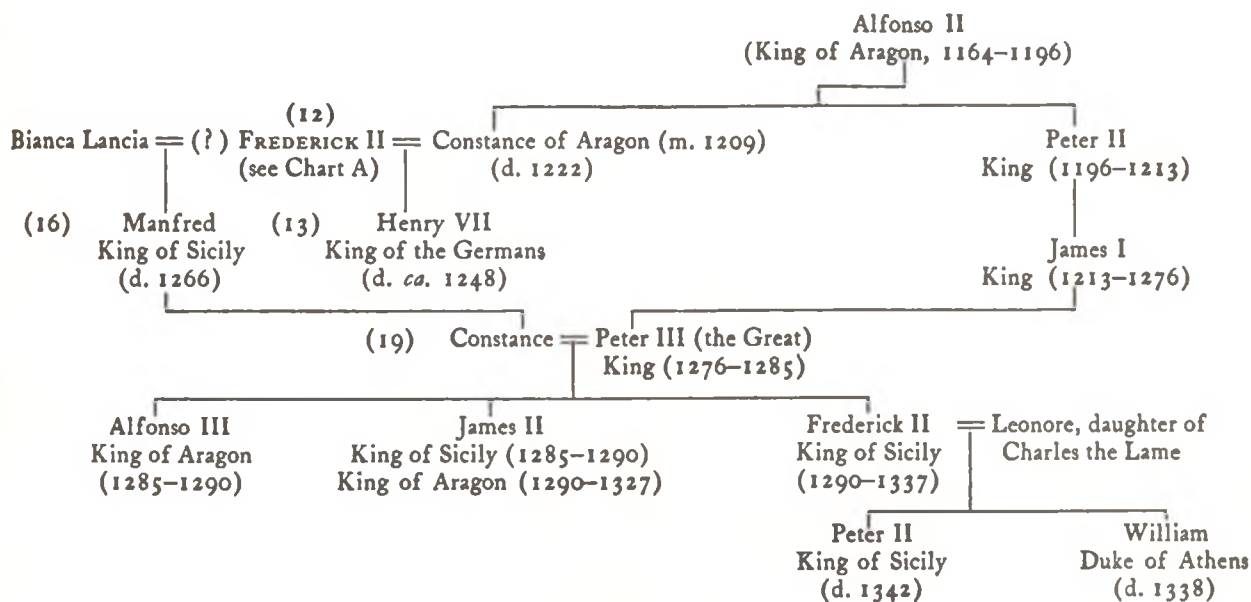

Rome, excommunicating right and left and preaching crusades against Conrad, the heir to the Empire and to Sicily. The Pope sought in vain for a rival claimant, offering the crown successively to Charles of Anjou, to Richard of Cornwall, and even to the young son of Henry III of England, Edmund of Lancaster, each of whom declined the honor. In 1254 Conrad died, leaving only Conradin

⁵ *Sonnet*, by Simone Dall'Antella, thirteenth century. Translated by Dante Gabriel Rossetti, who thinks it refers to Henry of Luxembourg. It is, however, even more expressive of the broken spirit of Frederick's son. Henry of Luxembourg was poisoned.

Lancia, a Sicilian noblewoman whom Frederick is said to have married on his deathbed, was a great favorite of his father, enjoyed much of his companionship, and shared many of his literary and other tastes. To the readers of the *De Arte Venandi* Manfred's is a well-known name. When the Emperor died, he appointed Manfred Viceroy of southern Italy and Sicily under Conrad IV, and when Conrad died Manfred did what he could to support the claims to the throne of the young Conradin, who was in Germany under the

⁶ See footnote 1, p. 482.

care of his mother, Elizabeth of Bavaria. In 1258, however, Manfred, in order to maintain the rights of his family, was crowned King of Sicily and Italy at Palermo and took up his residence at Barletta. Urban IV carried on the feud against the Hohenstaufens, excommunicated Manfred, and again offered the crown to Charles of Anjou, who this time accepted it.

Charles moved south well-equipped to oppose Manfred, who brought up his army to Capua. The contending forces met at Beneventum. As the battle was turning against him and Manfred saw that his German barons were deserting him, he tried to rally his men and rushed into the thickest part of the melee, where he died, performing deeds of valor as became a scion of his race. The Pope refused him Christian burial and even ordered that his body be taken from its first resting place beside the bridgehead over the Cadore at Beneventum. He was reburied outside Papal territory and the kingdom, on the banks of the River Verde in the Abruzzi.

Or le bagna la pioggia e move il vento
Di fuor dal regno, quasi lungo il Verde,
Dov'è le trasmutò a lume spento.⁷

We would be glad to believe the tradition that the good monks of Monte Vergine went at night and bore the body of the young king to the monastery he had befriended and there buried it in secret. There are, however, no records to substantiate this legend.

Charles of Anjou, not content with seizing the Kingdom of Sicily and Italy, imprisoned Manfred's widow Helena and her young children. Only one daughter, Constance, escaped his vengeance.

(17). *Enzio* (1225-1272). For an account of this last surviving son of Frederick let us turn to Dante Gabriel Rossetti, who tells us: "The unfortunate Enzio was a natural son of Frederick II, and was born at Pa-

lermo. By his own warlike enterprise, at an early age [it is said at fifteen!] he subjugated the Island of Sardinia, and was made king of it by his father. Afterwards he joined Frederick in his war against the Church, and displayed the highest promise as a leader; but at the age of twenty-five he was taken prisoner by the Bolognese, whom no threats or promises from the Emperor could induce to set him at liberty. He died in prison at Bologna, after a confinement of nearly twenty-three years. This was a hard fate indeed for one who, while moving among men, excited their hopes and homage, still on record, by his great military genius and brilliant gifts of mind and person." Rossetti has translated for us a sonnet of Enzio's reflecting a spirit of resignation to his hard fate:

ON THE FITNESS OF THE SEASONS

There is a time to mount; to humble thee
A time; a time to talk, and hold thy peace;
A time to labour, and a time to cease;
A time to take thy measures patiently;
A time to watch what Time's next step may be;
A time to make light count of menaces,
And to think over them a time there is;
There is a time when to seem not to see.
Wherefore I hold him well-advised and sage
Who evermore keeps prudence facing him,
And lets his life slide with occasion;
And so comports himself, through youth to age,
That never any man at any time
Can say, Not thus, but thus thou shouldst have
done.

Besides these sons of Frederick there were other illegitimate sons and daughters, among them Frederick of Antioch, King of Jerusalem.

(18). *Conradin*, or *Conrad the Young* (1252-1268), Frederick's last legitimate descendant, the son of Conrad and Elizabeth of Bavaria, brings us to almost the last tragic event in the history of the ill-fated Hohenstaufens.

⁷ Dante, *Pur.* III, 130.

After the defeat of Manfred, Charles of Anjou instituted a rule of bloody oppression in Sicily and Italy, and allied himself with the Guelfs in Tuscany, thus rousing the ire of the Ghibellines of the North, who in 1268 sent messages to Conradin, now a youth of sixteen, begging him to come and head an uprising in Italy. Just as his grandfather Frederick had traveled north to claim the Empire, Conrad, with a small company of soldiers and a few faithful companions, among them Frederick of Baden, now journeyed south down the valley of the Adige to Verona. The Ghibellines flocked to his side from all parts of Italy. His standard was raised in Sicily, where the French were hated. In Rome he was welcomed with joy by the populace in spite of the papal ban. All were delighted with his youth, his grace, and his fair beauty. But the fatal denouement came swiftly. At the Battle of Tagliacozzo on August 23, 1268, his forces met the better-trained and -organized army of Charles and were defeated. He and his friends took refuge in the Castle of Astura on the Maremma shore, from whence they hoped to escape to Tuscany; but Giovanni Frangipani betrayed and sold them to Charles.

The last act of the great tragedy was played in Naples on the twenty-sixth of October, in the year 1268 . . . the infamous judge of an infamous king condemned the imperial boy and his noble companions to death, as "traitors to the sovereign, contemners of the Pope's commands, and disturbers of the public peace in Italy." Conradin's claim to the succession was just, and he and his friends were prisoners of war; to put them to death was a solemn and atrocious murder.⁹

And so, an appeal to the Pope having failed,

Conrad's young boy . . . perished—bright young Conradin, bright and brave, but only sixteen, and Pope's captive by ill luck—perished on the scaffold; "throwing out his glove" (in symbolical protest)

amid the dark mute Neapolitan multitudes, that wintry morning. It was October 25, 1268, Dante Alighieri then a little boy at Florence, not three years old; gazing with strange eyes as the elders talked of such a performance by Christ's Vicar on Earth. A very tragic performance indeed, which brought on the Sicilian Vespers by and by; for the Heavens never fail to pay debts, your Holiness!⁹

(19). *Constance*, Manfred's daughter, as we have seen, survived. She was married to Peter III of Aragon, and to her was carried, it is said, that glove of Conradin's by the faithful John of Procida. John, Crawford tells us, "was a noble of Salerno, brought up in the School of Medicine [that Frederick had revived], a man of letters of singular wisdom and a very skilled physician." He had been one of the witnesses to Frederick's will, a friend and counselor to Manfred. He now took refuge in Barcelona with Constance and Peter, whom he urged to come to the aid of Sicily, which was ripe for rebellion. Peter consented and John of Procida, now an elderly man, proceeded to Sicily, where he "prepared the way." Peter III set forth, going first to Tunis, which he conquered, then, in 1282, was on his way to Sicily when there occurred in Palermo that incident that set the island aflame in revolution. Briefly: A French officer, walking in an Easter Monday holiday crowd, insulted a Sicilian bride, thrusting his hand into her bosom. The voice of her husband rang across the meadow: "Now let these Frenchmen die at last!" The Palermitans responded by killing with whatever means came to hand every Frenchman in the city, thus initiating the Massacre of the Sicilian Vespers, the terrible revenge by which fourteen years of misrule, insult, and violence were requited. Within a few months there was not a living Frenchman in the whole of Sicily. Charles's resistance was vain, and Peter was chosen King by the nobles at a meeting in the little Church of the Marto-

⁹ F. Marion Crawford, *Rulers of the South*.

⁹ Carlyle, *Frederick the Great*, Book II, chapter vii.

rana. Peter III accepted and promised to rule by the laws of William the Good. Thus the descendants of Tancred d'Hauteville returned to the throne. The last of these in

the direct line was another Peter, King Peter II of Sicily, who by some strange circumstance lies buried at Palermo in the same tomb as his ancestor, the great Emperor Frederick II.

“And in September, O what keen delight!
Falcons and astors, merlins, sparrow
hawks;
Decoy-birds that shall lure your game in
flocks;
And hounds with bells; and gauntlets stout
and tight.”

—FOLGORE DA SAN GEMINIANO
(twelfth century)



PLATE 167.—Page from the Manesse Manuscript at Heidelberg, fourteenth century. It shows the young Conrad, accompanied by Frederick of Baden, his friend "faithful unto death," setting forth upon a hawking expedition.
(By permission of Insel-Verlag, Leipzig.)



PLATE 168.—Conradin, or Conrad the Young (1252–1268), last legitimate descendant of Frederick, executed at Naples by Charles of Anjou.



PLATE 169.—Second view of the statue of Conradin shown in Plate 168, by Thorwaldsen, standing in the Church of Santa Maria del Carmine, Naples.



PLATE 170.—“Il Falconiere,” or “Love and Jealousy,” painting by Tranquillo Cremona. Courtesy of the Director of the Galleria d’Arte Moderna, Milan.

NOTES ON THE PORTRAITS OF FREDERICK II AND OF HIS SON MANFRED



IT WAS NOT the custom in the Middle Ages for portrait busts of monarchs to appear on their coins. In fact the Roman art of portraiture had long since fallen into disuse and its revival by Frederick in the busts on the Capua Gate was a distinct innovation. However, E. Winkelmann has made a very careful study¹ of nearly all the known examples (thirty-six in number) of the Augustales, the gold coins of Frederick II first minted at Brindisi and Messina in 1232. He found that all the specimens examined conform to a single, definite type, with one exception—that belonging to the Münzkabinet of the Kunsthistorische Sammlungen in Vienna.² Winkelmann points out that, although minor differences in individual coins indicate that a number of dies were used in the making of the Augustales, the features of the wreath-crowned head are always taken from the same model, albeit some of them present a rounded and younger appearance, whereas others are sharper and older looking.

The unique specimen in the Vienna Münzkabinet is stamped with a head wearing a royal crown instead of the laurel wreath of all the other Augustales. The features on this coin seem to be those of a younger man, yet resemble those on the rest of the heads. Winkelmann draws attention to the fact that

¹ "Über die Goldprägungen Kaiser Friedrichs II für das Königreich Sicilien und besonders über sein Augustalen," *Mitt. des Instituts für Oesterreichische Geschichtsforschung*, XV Band, Innsbruck, 1894.

² For our photographs we are indebted to the Curator of that collection, who kindly permitted one of us to handle and examine these beautiful coins.

this Augustale, with its crown, resembles the head of the Daniele Gem,³ prepared for Marchese Francesco Daniele from a cast, made under his supervision, of Frederick II's bust that stood over the Capua Gate between the portrait busts of Piero della Vigna and Thaddeus de Suessa. The original of this bust was destroyed by the soldiers of Murat during the Napoleonic occupation of Italy, but the translators have good reason to believe that the cast itself is still in existence and in the hands of the Marquis Daniele's descendants.

Some thirty-five years ago, Dr. Cresswell Shearer visited the Marchese Daniele at his villa near Caserta and was shown, among other treasures, a plaster bust of remarkable appearance with "very wonderful features." He was told by the Marchese (a son of the Marchese Francesco) that it represented Frederick II. In 1938, when again in Italy, Dr. Shearer met the wife of the Marquis Giuseppe Daniele and spoke of the bust that had been shown him by her late father-in-law. She was much interested and very kindly gave him a small snapshot of the cast, with the information that another print of this photograph had been given to Dr. Ernst Kantorowicz to use in his work on Frederick II. It is from the photograph given Dr. Shearer that the colored portrait of Frederick used as the frontispiece to this translation was prepared by E. T. Osborn under Dr. Shearer's supervision.

³ The present whereabouts of this gem are unknown, but it is portrayed in Raumer's *Hohenstauffer*, Vol. III, and on the title page of Huillard-Bréholles' *Histoire Diplomatique*.

In the same volume as that in which he published his article on the Augustales, Winkelmann gives also a short account and reproduction of an imperial seal of Frederick II (p. 415), the head of which seems to him to correspond with that shown on all the coins and on the Daniele Gem. The reader may compare it with the first royal figure on folio 1^r of the Vatican Codex (see Plate 3, p. xxxi).

The lower kingly figure on folio 1^r (Plate

3, p. xxxi) and that on folio 5^r (Plate 5, p. xxxiii) of Vatican MS. Pal. Lat. 1071 have been presumed to represent Manfred. For comparison we have reproduced also the best-authenticated portrait of Frederick's son — that in Manfred's Bible, now reposing in the Vatican Library⁴ (Plate 6, p. xxxiv).

⁴ Vatican Codex, MS. Lat. 36, fol. 522.



**Favorite Birds of the Chase Probably Well
Known to the Emperor**

FAVORITE BIRDS OF THE CHASE PROBABLY WELL KNOWN TO THE EMPEROR

HE MUST NOT be forgotten at the outset of this review that the scientific status of the Emperor included well-established positions—expert falconer, erudite ornithologist, well-informed forester, and accomplished writer on all natural history subjects. He was a deep student of Pliny, Aristotle, Aelian, and many other writers, some of whom, well known to him, are to us only names.

The authorities he consulted in the course of his literary career were, like some of his own productions, probably lost in the turmoil of the twelfth and succeeding centuries.

One of the purposes of this chapter is to give the reader an opportunity to compare a number of modern scientific descriptions of avian species with those depicted by Frederick II as set forth in the six-book edition. It will be seen at once that the Emperor has furnished us with a meticulous and remarkably accurate account of the principal birds of prey that he and his court employed in hunting, involving few errors in diagnosis or ecology. He was well aware, for example, of the many changes in coloration and plumage markings as his birds grew from immaturity to adulthood; how they appeared before and after each moult; and how slightly birds of the same race during the first few months of life resemble their parents.

Conclusive evidence of the Emperor's belief that a chapter on the mystery of the moult was needed to complete his review of ornithology is seen in his repeated references to the importance of the subject. He was perfectly well aware, for example, that the very

existence of rapacious birds depends upon the regularity of their moult, and that falcons do not lose any of their feathers during the first year when the weakness of their immaturity would mean starvation and death were they further handicapped by falling plumage. Moreover, the moulting process in rapacious birds is a very gradual one; very few of the essential plumes are lacking at any one time, so that their powers of flight and of food provision are not much lessened. Indeed, the pinions, beginning with the seventh feather of the wing, fall out one by one, the loss of the other feathers being spread over a period of months before the mutation is complete—quite a different story from that of swimmers and rasorial birds, for example, which, having no urgent need for a constant supply of flight feathers, change their plumage early and rapidly.

Let us consider at some length the birds employed in hunting by Frederick II, to be followed by an account not only of the species hunted but of others of less importance to the falconry of the Emperor with which he was probably well acquainted. Together these categories form a fairly complete catalogue of the birds of mid-Europe (with remarks on a few avian species in both the Near and Far East) as recognized in the Middle Ages.

The first two books of the Emperor's *De Arte Venandi cum Avibus* furnish descriptions of many rapacious as well as of numerous harmless birds. The latter category comprises, generally speaking, the ordinary prey of the former. In employing these lists it must be remembered that the majority of

vernacular Latin names of birds have been satisfactorily established; but in some instance this is not the case. We have noted these differences of expert opinion and, when they are of value, have given our own conclusions about the matter.

Since the present translation is primarily of medieval Latin into modern English, we have not padded the work with avian synonyms of German, French, or Italian origin, although we have occasionally broken this rule when there was definite need of the transgression.

At the outset let it be said that the term *falcon* is commonly confined by ornithologists to the long-winged hawks; also that by it the falconer means, unless some other designation is purposely employed, the female of the species. Whenever, for example, he refers to his own or to some other man's particular peregrine he alludes to the larger, more courageous, and more useful sex and not to the (male) tiercel.

It may be added that for many centuries it has been the habit of falconers further to distinguish hunting birds by training only long-winged hawks to seek the lure. Short-wings are taught to come to the fist; and Frederick's many references to his work on hawks lead us to believe that he favored their use in sport and would have prepared instructions in the art of taming and training "hawks of the fist."

In short-winged hawks the wing is comparatively short at the outer joint. When fully expanded, the extremity has a rounded contour. The first primary feather is very short; the fourth is the longest. Short-winged hawks have no notched upper mandible, but theirs is curved in a regular line to its points. Their eyes are yellow—either dark or light. The tail is large and long.

The foregoing simple characters are sufficient to enable the amateur to recognize these two (hawk) species and to distinguish them

both from the eagles, which form by themselves a distinct hunting class. In the *aquili-formes* the tail is shorter and heavier than in the hawks. The outer wing joint is also shorter than in the falcons. The legs are, in proportion, stouter. In size the smallest eagle is much larger than the largest hawk.

To this crude classification of diurnal birds of prey has been added, mostly by the French, a grouping based on their flight methods. The long-winged hawks are called "rowers" (*rameurs; ramiers*), because their aerial progress is that of a sculler striking the water with successive strokes of his oars. Other rapacious birds, including short-winged hawks and eagles—indeed all birds that have circular or rounded wings—are called "sailors" (*voiliers*), since they, as opposed to the rowers, mainly depend upon flight gained by wind pressure against their wings, as a boat is propelled by the force of aerial currents on her sails. This difference in body propulsion is seen not only in ordinary flying but when birds of prey are in pursuit of their quarry.

A. *Long-winged hawks*

The chief character of true falcons or long-winged hawks is the invariable scheme followed in capturing their prey, by "stooping," or descending, like a bolt from the blue, from a position high in the air upon the quarry beneath. Instinctively the falcon is aware of the decided advantage of seeking and maintaining a greater altitude than her prey, and even when there is no victim in sight she holds this advantageous position and "waits on" until it appears below her. In training, also, the falconer encourages his birds to employ this added force of gravity and downward plunge in making a kill.

Although it is quite probable that Frederick II was acquainted with the great majority of both Occidental and Oriental diurnal birds of prey and knew them much as they are depicted in modern textbooks, it is not our

intention at this time to do more than mention certain races and subspecies of European and Far Eastern accipitres. Moreover, so well informed was Frederick that he appears to have been aware how plumage changes due to age had led both ancient and medieval naturalists wrongly to regard as of specific rank individuals whose feathered differences are merely color variations in the same bird.

Long-winged hawks may be recognized also by the following briefly stated peculiarities: the upper mandible has on each side at its lower third a deep notch, thus making on the cere side a tooth-like projection. The eyes are dark brown. The wing feathers, at the outer joint and when closed, extend more than halfway between the margins of the tail-coverts and the end of the tail itself; in some species they reach still farther down. The second outside primary feather of the wing is generally the longest, or at least it is never shorter than the other quills. The eyes (irides) are various shades of brown.

The vernacular name *gerfalcon* (*alias gyrfalcon* and *jerfalcon*) is now applied by most ornithologists to the Norway species, a synonym derived from the superior gyrating or circling qualities of the bird; but falconers call every Scandinavian falcon a "ger," a "gyr," or a "jer"—a practice that is becoming quite common in print.

After all, differences in the northern species can be explained on the evolutionary ground of different climatic conditions apart from the question of interbreeding. As E. B. Michell (*Art and Practice of Hawking*, p. 14) says, the lightest variety of one species is almost indistinguishable in color from the darkest of the next in order, and there is less difference between one Iceland falcon and either of two allied species than between selected specimens of *Falco islandus*.

Both the larger and stronger female gers and the smaller males have to their credit a greater array of quarry than has fallen to the

lot of other falcons. This list has undergone little variation through the centuries before and since Frederick's time. The gers, females and tiercels, have been successfully flown at both indigenous and migrant species of teal, widgeon, pheasants, rooks, wild geese, cranes, ducks of every species, gulls, herons, crows, woodcock, land rails, curlew, magpies, doves, partridges, pigeons of various kinds (the wood pigeon in particular), starlings, black game, ptarmigan, grouse, plover, snipe, jackdaws, kestrels, bitterns, all the sea fowl inhabiting or visiting the northern coasts of Europe (including occasional swans), and some species of mammals, such as hares and rabbits. They have been known also to kill (in the Far East) the francolin and the florican, kites, bustards, and buzzards.

Michell (*op. cit.*, p. 15) notes that the flight of the gerfalcon is marked by an appearance of power suited to its size, dignity of pose, and imperial bearing. It combines with an extraordinary degree of swiftness a wonderful ability to turn on the instant. When trained to wait on, the ger does so in regal style, and its stoop at the proper moment is so impetuous and swift that the aerial prey is less frequently clutched than struck down with a passing blow, and is often found killed or disabled by the violence of the first stroke. Frederick knew this impetuosity of the larger falcons and warns his readers not to work the birds for too long periods lest they lower their "pitch" or lessen their mounting power.

Both sexes of the Greenland falcon (*Falco candicans*) have the whitish plumage of all the northern gerfalcones. Adults are barred with faint, light grayish brown on the upper parts, with spots of the same below; immature birds are much darker. As age advances the brighter colors slowly disappear until the older birds appear to be almost entirely white. Eyelids, cere, feet, and legs are blue-gray in young birds; but this color changes to yellow

after the first moult, becoming more saffron after each change of plumage. The female has an average length of 23 inches, the male of about 20 inches. Tail, female, 9 inches; male, 8 inches. Wing, male, 14½ inches; female, 16½ inches.

This species is the noblest and most majestic of the *Falconidae*. It was the most highly prized as well as the most difficult to procure of all the hunting birds utilized by the upper nobility. Indeed, it was, par excellence, the Imperial Falcon, whose services were rigidly reserved for emperors, kings, and princes.

Except that the Iceland falcon (*Falco islandus*) is somewhat larger, both sexes resemble the Greenland gerfalcon. The following are average measurements: Female, length, 24 inches; male, 21 inches. Wing, female, 17 inches; male, 15 inches. Tail, female, 9¼ inches; male, 8¼ inches. Young birds have the upper parts dark grayish brown, each feather being barred and tipped with light gray. The adult plumage below is whitish, splashed over the flanks and breast with streaks and spots of gray-brown. These spots, at first longitudinal, alter with each moult. They then lose their brown shade, which gradually disappears, and the markings on breast and flanks become fewer and more heart-shaped. The lower neck and sides of the head are quite white, and there is the same tendency to lose color with age, as in the Greenland species. *Falco islandus* was rare and a great favorite in regal and imperial circles during the Middle Ages.

The coloration of the upper plumage in immature birds of the Norway falcon (*Falco gyrfalco*) is lead-brown. This area, as well as the flight feathers, have their margins and tips buff or brown. The back, low down, is occasionally tinted gray. The tail is barred with dull buff and has white tips. Longitudinal blotches of dull brown on a white background nearly cover the breast. The first

moult is followed by a lessened distinctness of these marks, an effect that increases with age. The superior plumage is slate-gray, barred with grayish blue. The tail coloration changes to slate-gray with narrow bars of gray-brown. The cere and eyelids of immature birds are bluish gray, and the legs are lead color, all turning to yellow in adults.

The Norwegian falcon, more than any other Scandinavian species, resembles the peregrine. On the other hand, it is the gerfalcon that least approaches the Greenland variety in color and usefulness. Norway falcons are fine hunters but are more liable to disease than the peregrines.

Although the Labrador falcon (*Falco labradorus*) belongs to the ger family, it is infrequently found along Scandinavian coasts and has rarely been trained for hunting. It is much darker than the other gerfalcons, and it may be that it was unknown to the Emperor Frederick.

Although never regarded as of that rank of nobility granted the gerfalcons, the peregrine falcon (*Falco peregrinus*) is generally hailed as the most perfect combination of strength, health, speed, variety of flight, and courage of all birds; and it has often been declared by falconers that it would not be advantageous to alter in any degree or proportion those admirable qualities that make the female in particular the favorite hunting bird the world over. Moreover, another important fact adds to the unique position of this falcon in the realms of sport: she is found in nearly every part of the earth, a true cosmopolite. Our American counterpart is the duck hawk (*Falco peregrinus anatum*).

The prey of the peregrine is substantially the same as that of the ger, despite the truth of the generalization that the larger the hunter the bigger the game.

The average female peregrine is about 18 inches long; her wings are 14 inches, her tarsus is 2¼ inches, and her tail is 7 inches.



PLATE 171.—Mature female saker. (After Brodrick.)



PLATE 172.—Immature female hobby. (After Brodrick.)



PLATE 173.—Goshawk, immature female. (After Brodrick.)



PLATE 174.—Sparrow hawk. (After Bowdler Sharpe.)

The smaller tiercel (*tassel* or *tiercelet*) has an average length of 16 inches, with tail 6 inches, wing 12 inches, and tarsus 2 inches.

The feet, legs, cere, and eyelids of immature birds of both sexes vary in coloration from bluish gray to yellowish green or pale ocher; the mandibles are light blue-gray, becoming blackish toward and quite black at the tips; the claws (talons), as in all long-winged hawks, are black. As a result of the first moult, the entire upper plumage changes to slate-blue; each feather of this area is barred transversely and their terminals are tipped with light blue-gray shades.

Laterally and on the crown, the head is dark blue, as is the moustache also. The under parts become spotted or splashed with dark gray, irregularly transverse figures, that are tear- or arrow-shaped, particularly on the throat. These markings become more and more definitely transverse and bar-like after each moult. In aging birds these spots are less marked, until eventually they disappear, leaving a nearly pure white surface. The coloring of the feet in peregrines changes very early, assuming a yellowish shade even before the first moult; thenceforth it becomes very yellow, and at last is of a deep golden color. The irides are deep brown or brownish.

Within limits, the coloring, size, and shape of individual peregrines may vary considerably from immaturity to senility, and some falconers have endeavored to implicate these external characters with their hunting values. There is evidence to favor such a view.

Without repeating too often the verbiage of the Glossary attached to this translation, it might be well to emphasize here and perhaps repeat some of the vernacular terms that from the earliest times have been applied to hawks—especially to peregrines. These include certain words that are now seldom used. Until she moulted the hunting bird was often called a *red hawk* or *sorehawk* (L., *saurus*; Fr., *sor*) from the dominant color of the

plumage. The period during which she could legitimately be termed a *sorehawk* is from the middle of June until the middle of September. When the migrating season set in, she was referred to as a "passage hawk," being now the true peregrine, "wanderer" or "pilgrim" (Fr., *pélerin*). During Lent, corresponding generally to the approach of her first moulting season, the English called the hawk a *Lent-hawk*, *Lentener*, or *Lantiner*. When fully grown the bird was "summed," before that event "unsummed." Still earlier, i.e., shortly after she had been hatched or "disclosed," she was entitled an "eyas" (or *nyas*, Fr., *niais*). As soon as she gained the use of her legs she was a "ramage" hawk, and when she was able to jump from one branch of a tree to another near by she attained the dignity of a "brancher." The adjectives "gentle" and "slight" were given to young birds that were captured after they had forsaken their nest but before moulting. The uncaptured, free-flying adult hawk was known as a "haggard," from the Hebrew *hagar*, meaning "wild"; the same bird tamed became "intermewed." Of course there are numerous other vernacular terms applied in various states of health and disease to hunting birds, but these properly belong to and will be found in the Glossary.

Although the beautiful Barbary falcon (*Falco barbarus*), the so-called tartaret, is the smallest of the peregrine group, it is on the whole the most powerfully built and the best armed. The wings are longer and more pointed than those of other peregrines, while the feet, talons, and mandibles are larger in proportion to body measurements.

However, the coloring is about the same, except that young birds are of a lighter shade, the head has a ruddy tint, and the feet are yellower. The eyes are brown.

Length of female, 13½ inches; tail, 5½ inches; wing, 11½ inches; male, length, 12¾ inches; tail, 5¾ inches; wing, 10¾ inches.

The black shaheen (*Falco peregrinator vel atriceps*) is a favorite hunting hawk in the Far East, where she is still used in India and Persia. It is a much smaller species than the European peregrine, the female being about the equal of the Occidental tiercel in weight and length. The points of the closed wings reach nearly to the end of the tail. The coloring of the head is much darker than that of the peregrine; the sides of the head and the moustache are quite black. The body underparts are rufous. This falcon is more docile and more easily reclaimed than its European cousin. Its quarry is of the same character as that of the latter and, of course, includes many species not available to Western hunters.

During his several years' residence in Ceylon the senior translator had a rather unusual experience of the stoop of this pretty little hawk. He was on a collecting tour which included the famous Sigiriya Rock, in an almost inaccessible projecting ledge of which a pair of black shaheens had built an eyrie—also a fine observatory from which to watch for and secure daily food. A thousand feet below, at the base of the Rock, the translator shot a bird in midair, roughly a hundred yards away. Then from apparently a clear sky above there flashed past a dark object that grasped the bird just before it touched earth. In a wide circle the shaheen returned to her rocky nest. It was a wonderful performance, and caused no regret for the loss of a specimen.

A number of authorities claim a racial superiority and other virtues for the red-naped shaheen (*Falco babylonicus*), a peregrine relative.

It is somewhat smaller than the black shaheen but is easily distinguished from it by a prominent patch of chestnut red on the occiput.

The average length of the female is 17½ inches; wing, 13 inches; tail, 7¼ inches. The

male has a length of 15½ inches; wing, 11¾ inches; tail, 6¼ inches.

The feet of this bird are proportionally smaller than those of the European peregrine, and the body is shaped like that of the desert falcons. It is a docile bird, more tractable and affectionate than the other peregrines, and is easily caught. She will fly at almost any bird, and will tackle even the largest species. Individuals trained and flown in England are said to have been more hardy and more easily managed than the indigenous peregrine.

The finest of the desert falcons, the saker (*Falco saker*), is one of the largest and best hunting hawks of Central and Southern Asia. It is fully described by and was well known to Frederick II and his contemporaries. The bird has for that reason a special value in this translation. Its measurements about equal those of the gerfalcon, except that it has smaller feet. This fact (involving the shortness of the middle toe), as well as the poor quality of the plumage, gives it a lower rank than European peregrines in the eyes of Occidental falconers. In the East its common prey includes the kite, the bustard (*hubara*), herons, and a host of other avian species, including even the short-eared owl. The female saker also takes inferior mammals—hares and small deer—quite well. The male is called a sakret or sackeret.

Immature birds have the nape and crown of the head yellowish white, lighter over the eyebrows and on the forehead. The upper plumage is dull dark brown edged with rufous. The tail, except the deck feathers, is marked by a band of irregular, oval spots. There is a plainly differentiated moustache. The lower parts are buff-colored, with streaks of brown, darker on the flanks. The buff of the upper areas is lighter than elsewhere, becoming almost white about the chin. The legs, feet, and cere vary from pale blue to grayish green. In adult and very old birds one finds the upper coloration pale, sometimes

almost white. The flight feathers are barred with faint brown, the caudal plumage with light buff. The feet, cere, and legs assume a well-marked yellow color.

The lanner (*Falco lanarius*) is another desert hawk whose dimensions are nearly those of the peregrine. However, like the saker, the feet are comparatively small and weak, while the tail is long. The wings are long and heavy, and the feathers are inferior in quality to those of the peregrine. The species is readily distinguished from other hawks by the lighter coloration of the whole head. The female has a length of 18 inches, wing $13\frac{3}{10}$ inches, tail $7\frac{1}{2}$ inches. The male (lanneret) is $16\frac{1}{2}$ inches long, with wing 12 inches and tail $6\frac{1}{2}$ inches. In immature specimens the whole back from the nape to the tail-coverts is dark brown, and each feather is tipped with a light rufous. The tail and wing are dark brown, with narrow, rufous-buff markings at the tips. The lower feathers are dull white, variously marked in individual cases. The changes in adult and senile plumage are not as marked as in other falcons. The feet and cere assume in adults a yellow-gray. The lanner, rather a stupid bird, with a coarse appetite, is not as satisfactory (at least in Occidental hands) to tame and train as the nobler birds.

The lugger (*Falco jugger*) is a useful member of the Oriental *Falconidae* but is little known outside the Indian peninsula. She is (or was) much used by the natives for capturing a great variety of quarry. The female has a length of 17 inches; tail, 8 inches; wing, $13\frac{3}{10}$ inches. The male has a length of 15 inches; wing, 12 inches; tail, 7 inches.

A species that is or was common enough in its habitat, the eastern shores of the Mediterranean, the Eleonora falcon (*Falco eleonore*) may well have been utilized in ancient and medieval times as a hunter; but the bird has not been widely employed in Europe. It

lives chiefly on other birds, including the hoopoe and all species of quail. Measurements are as follows: female, length, $15\frac{1}{2}$ inches; tail, $7\frac{1}{2}$ inches; wing, $13\frac{3}{8}$ inches; the male, length, $13\frac{1}{2}$ inches; wing, $11\frac{3}{4}$ inches; tail, $6\frac{1}{2}$ inches. The Eleonora resembles the hobby. She is quite dark below, with much black and deep rufous on the under surface of the wings. Although the wings are long, they do not project, like those of the hobby, beyond the tail. The feet, at first light yellow, later are of a decided orange.

The hobby (*Falco subbuteo*) is the most charming and attractive of the smaller falcons. It may easily be identified by the length of its wings, which, when closed, extend well beyond the tail. Measurements are (average): female, length, $13\frac{1}{4}$ inches; wing, $11\frac{1}{4}$ inches; tail, $6\frac{1}{2}$ inches; male, length, $11\frac{1}{2}$ inches; wing, $10\frac{1}{2}$ inches; tail, $5\frac{1}{2}$ inches.

The coloring of the hobby is distinctive; immature birds are very black above, each feather being tipped with reddish brown. On the other hand, the lower plumage is of a light cream color covered with deep-brown splashes, the sides of the head and throat being tinted buff. The eyebrow is black, with a streak of buff above it; and there is a patch of the same shade of black below the eye itself. The moustache is broad and deeply marked. The deck feathers are unmarked; but the others definitely exhibit, both above and below, ten crossbars of light brown. Both the cere and the feet of young hobbies are gray-green, but the latter soon become yellowish, later on developing into gamboge and finally deep orange. The upper plumage of adults uniformly alters to dark slate, which is quite black toward the head. The feet of the hobby are comparatively small, the legs slim and weak. Although this little hawk was praised as one of "my lady's birds," her hunting qualities also gained favor in medieval times with falconers generally.

She, however, does not appear to have been as well received as the still smaller merlin.

The name of the merlin (*Falco aesalon*), according to the older English falconers, was (and is still) reserved for the female, by far the stronger and more courageous of the sexes. The male is called a jack. Their coloring and color changes are unusual in accipitrine annals. Average measurements are as follows: female, length, $11\frac{3}{4}$ inches; wing, $8\frac{3}{4}$ inches; tail, $5\frac{1}{2}$ inches; male, length, $10\frac{3}{4}$ inches; wing, $8\frac{1}{4}$ inches; tail, $4\frac{7}{8}$ inches. The male merlin weighs from $6\frac{1}{4}$ to $6\frac{3}{4}$ ounces; the female about 8 ounces. The entire upper plumage of females and immature males is a deep, brilliant chocolate. The feathers of the back and upper wing-coverts are tipped with light-brown and barred with buff, which is more noticeable on ruffled plumage. Each feather has a well-marked black shaft. The under surface of the wing is a silvery gray covered by spots and bars of brown. The upper surface of the tail feathers is light brown; underneath they are tipped with white, having grayish bars crossed by oblique, parti-colored markings. There is a dark-brown moustache (and a patch of the same color) on the face, but these markings are not as pronounced as on the peregrine and the hobby. Mandibles are bluish, darker toward the tip, which is decidedly black. The cere and lids are bluish gray. Feet and legs are of shades varying from green- or blue-gray to yellowish. The toes are flexible, thin, and long. Adult females do not change much as age advances, but males do. The whole upper plumage of the latter shows an alteration from brown to a deep slaty-blue, becoming grayish black on the long feathers of the wings. The slightly barred tail displays a single band of very dark gray that involves the terminals. The flanks are russet; the breast is cream-colored at the chin above, but merges into russet below. In both sexes the third caudal feather is exactly as long as

the second. Both tail and wing feathers grow stiffer, stronger, and stouter with age, although the former are often shorter than before the first moult. Occasionally old females—like aging kestrels—take on the characteristic markings of male birds. In adults the feet, legs, eyelids, and cere change to light orange or deep golden.

The prey of merlins includes, as a general rule, the smaller birds, such as larks, black-birds, pigeons, partridges, quails, thrushes, and snipe. Unlike most falcons this courageous little hawk will follow quarry into covert and when the victim is larger than herself will strangle it by a strong grip on the neck.

There is both an Indian and an African race of merlins; the former (*Falco chicquera*), a little larger than the European species, is still used for hunting in the Far East. There its avian quarry includes rollers and the hoopoe. The African merlin (*Falco ruficallis*) presents about the same external appearances as her European relative, but the markings on the breast are more numerous and closer together.

Michell believes that the chief value of the kestrel (*Falco tinnunculus*) is to provide an easy means of teaching amateurs how to tame and train the more useful but more troublesome hunting birds. Having graduated from this elementary school, the embryo falconer will more readily understand and succeed with peregrines and gerfalcons. In the open the kestrel is of little use for true sport. It may, while waiting on, take a sparrow or other small bird thrown to it, but practically no wild quarry, except perhaps field mice. In reducing the number of these small mammals it may be a valuable agricultural agent.

Its actual powers of flight are, however, excellent. It can remain on the wing most of the day, not soaring but hovering (hence one of its names, "windhover") in the air while

quartering the earth beneath in search of its small prey. It is a friendly bird, not at all shy, readily tamed, and capable of education within certain limits.

The measurements of the average-sized kestrel are as follows: female, length, 13 inches; wing, 9 inches; tail, 7 inches; male, length, 12 inches; wing, 8¼ inches; tail, 6½ inches.

The upper plumage of immature males as well as of adult females has on their upper parts transverse bars of black. The flight feathers are dark brown. The head, lower back, and upper tail surface of adult males are slate-gray. The tail, tipped with white, has a broad black band near its end. The upper portion of the back, the shoulders, and the upper wing-coverts are light chestnut, shot with triangles of black. There are dark-brown spots and splashes on the abdomen. Legs, feet, and cere are pale grayish yellow in the fledglings, becoming brighter in adults.

A number of other *Falconidae* have been trained and to some extent employed in hunting small birds. In the proposed treatise by the Emperor on hawks all these would probably have been described. Suffice it to refer to the lesser falcon (*Falco minor*), the Javanese falcon (*Falco melanogenys*), and the Punic falcon (*Falco punicus*) as among accipitres of peregrine character and sporting rank. Races of *Falco lanarius* and from the expert falconer's standpoint resembling that bird are the South African lanner (*Falco biarmicus*) and the Tunisian lanner or alphanet. Both are local varieties whose predominant color is more decidedly rufous than that of their better-known relative.

There are distinct differences not only in size and plumage coloration but in mentality and usefulness as hunting birds between the long-winged and the short-winged hawks.

B. *The short-winged hawks*

Not the least important difference is in their methods of attacking their quarry.

Short-wings cannot be taught the aerial "wait on" that gives their nobler cousins a certain advantage in the open-air chase. Now and then a short-winged hawk will stoop and attack her prey from above; however, she does not attempt to disable or kill it by a single blow (like the long-winged bird) but follows behind in an attempt to "truss" or "bind" to it. Succeeding in this effort, she crushes, impales, and finally kills or disables the victim by means of her strong feet and her long, needle-pointed claws. She will also follow her victims into covert, or will keep watch for the intended or injured prey on some neighboring tree or wall or even on the falconer's fist. She is ready for work at any time of the day, and need not be restricted to particular game species but will take almost any kind, bird or mammal, that does not exceed her capacity. Thus, as "pot-hunters" the short-wings are the most useful of the hawks; but they do not induce the dramatic excitement provided by the theatrical—even awe-inspiring—spiral climb of the nobler falcon, as she proudly reaches a position as high as the clouds and far above the quarry. Then comes the dramatic, lightning plunge, when, with folded wings, the avian thunderbolt strikes her prey.

There is, however, one decided advantage in using the short-winged hawk, in that she can be flown in wooded or partially cleared country where long-wings cannot operate. Also the flights of the former are comparatively short and they have fewer opportunities or temptations to "check" or to "rake away"; and in the extensive course pursued by the nobler falcon the latter is often out of sight when the kill is made. Moreover, if the larger falcon is lost, much time may be wasted in searching for and reclaiming the strayed and distant bird.

There are many races of the goshawk (*As-*

tur palumbarius), varying in size, coloration, and mental development. Females and immature males have a dull-brown upper plumage which is edged and crossed with lighter brown. The tail is also barred with five broad, dark-brown bands, corresponding to the same number of gray-brown bands on its under surface. The remainder of the under-surface plumage is cream-tinted, splashed or streaked on the flanks and breast with longitudinal spots of deep brown. The irides are peculiarly attractive, and of a brilliant grayish yellow. They are so bright that the Greeks called this species ἀστειρίας ἰέραξ—"the star-eyed hawk." After the first moult the dark-brown splashes on the underparts change gradually into bars that are more regular and narrower, while the markings on both surfaces of the tail alter to four wide bands of dark gray or brown. The legs, feet, and cere become yellow; and the beautiful eyes assume first a deep yellow, later a dark orange. Goshawks vary much in strength and size; but although the female may attain a length of 25 or 26 inches, she will not weigh more than a large peregrine. Her long, diminutive head contrasts with her large muscular thighs and especially with her feet. The latter are provided with immense claws, the first and hind toe being armed with talons capable of a vise-like grip.

The goshawk is a famous hunting bird in medieval annals, and we feel certain that the Emperor intended in his promised work on hawks to give this bird a prominent place. As previously stated, the goshawk has a catholic taste in prey and does not disdain hares, rats, weasels, and "such small deer" any more than wild ducks, herons, water hens, jays, crows, and other birds. In India her hunting fare also has a wide range, including minas, florican, jungle fowl, and even such larger quarry as geese, kites, and peafowl.

The illustration (p. 524) shows a remarkable example of the northern race of gos-

hawks, a Finnish female eyas, five years old in 1938. She is named "Tamar," the present owner being Mr. T. A. M. Jack, editor of *The Falconer*. This unusually fine bird has passed through several ownerships. She is still very wild, very fierce, and heavy even for a Finlander, which is generally larger than southern birds. This magnificent specimen is in full plumage and good hunting condition. During her career with Mr. Jack her chief quarry has been water hens and rabbits.

The sparrow hawk (*Accipiter nisus*) and its many variants may be identified by their slender legs, long, weak middle toes, and very small head. Immature birds have sepia-colored mandibles and upper parts, each feather being margined with rufous. The dark-brown feathers of the wing show five bars of darker brown on the outer primaries. The brownish tail has also five dark brown bars. The lower plumage is whitish with a rufous tint, and is marked by irregular patches of gray-brown. In mature specimens one notes that the brown upper plumage of youth has taken on a slate-gray color and that the marginal lighter color has disappeared. In full-grown birds the breast and underparts show bars of mixed brown and fulvous. The feet and legs are yellow or golden, while the irides become first light, then deep orange. The average measurements of this hawk are: length of female, 15 inches; wing, 9 inches; tail, $7\frac{3}{8}$ inches; tarsus, $2\frac{2}{5}$ inches; male, length, 12 inches; wing, 8 inches; tail, $6\frac{1}{4}$ inches; tarsus, $2\frac{1}{10}$ inches. The female sparrow hawk, being so much larger, stronger, and perhaps more courageous than the male, can be flown at almost any bird not larger than a partridge, pigeon, woodcock, or snipe. The Indian races were much utilized for this sort of game. They were well known to the Emperor Frederick II, and we have frequent mention of them in the pages of the *De Arte Venandi*.

Of other sparrow hawks employed for hunting in both Europe and Asia may be



PLATE 175.—Golden eagle (*Aquila chrysaetus*, var. *canadensis*), owned and trained as a hunter by H. R. Ivor, Toronto, Canada. Photograph by Hugh M. Halliday.



PLATE 176.—Golden eagle (*Aquila chrysaetus*, var. *canadensis*). Second view.
Photograph by Hugh M. Halliday.

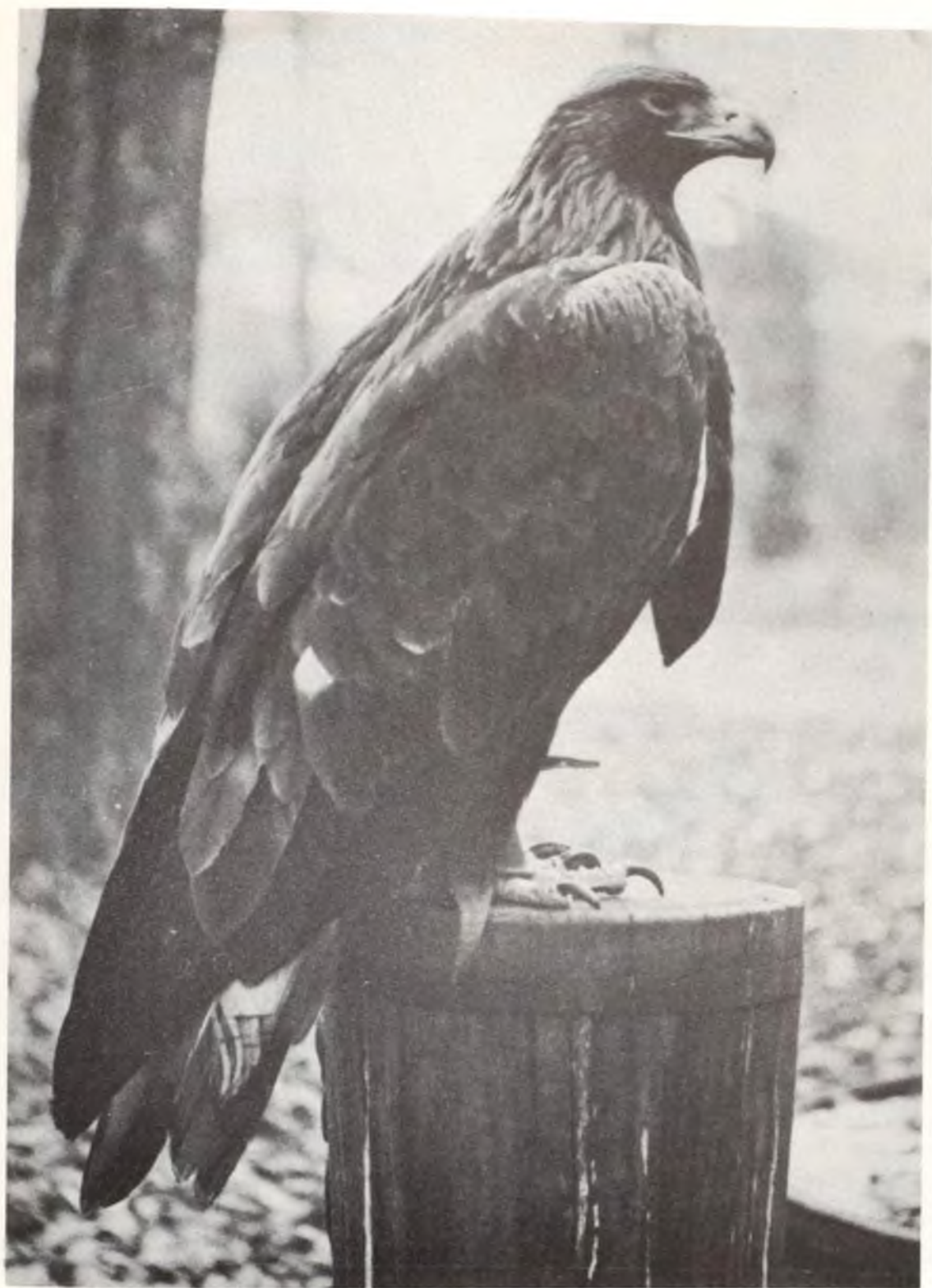

PLATE 177.—Hunting eagle, Reichsfalkenhof, Germany. (Photo by Fischer.)



PLATE 178.—Intermewed female goshawk, "Tamar," six-year-old eyes, 1937.
Courtesy of the owner, T. A. M. Jack.

mentioned the Besra sparrow hawk (*Accipiter virgatus*), smaller than *A. nisus* but quite the equal of that hawk in hunting ability; and the Levant sparrow hawk (*A. brevipes*).

C. The eagles

The employment in the chase of such large and powerful birds as eagles has been almost entirely confined to the Near and the Far East, where their quarry has been mostly mammalian. They are referred to by Frederick II, but no directions are given by him for training them to catch birds. Moreover, their great weight, making them difficult of transport on the fist, and the impossibility of teaching them to "wait on" stand in the way of utilizing them as freely as the peregrine. On this subject we are chiefly indebted to J. E. Harting, whose articles in the *Field* of 1890 on "Trained Eagles" and the "Berkut of Turkestan" are well worth perusal. From them much of the following information is derived.

Eagles are usually carried in the open on a crutch formed of a crossbar at the top of a pole. The lower end of the upright may be fitted to a horse's saddle and attached to the rider's girdle. Their lure is a stuffed skin made to resemble the quarry the eagle is expected to capture. Most eagles have uncertain tempers that tax the patience of the owner; and they are not as reliable during or after the training period as are the hawks. Their speed in flying, though greater than that of any mammal marked as prey, is not equal to that of hawks. In the wild state they capture their quarry by first soaring and then quartering the ground below them. Thence they execute a forceful stoop and drop on the head, face, or back of the victim, to which they cling until the captive is dead or completely disabled. Of the numerous members of the genus *Aquila*, used as hunters, we briefly describe the following, although the list might be greatly extended.

The golden eagle (*Aquila chrysaetus*) is the aquiline species (of worldwide distribution) most commonly employed for many centuries in the ventry of Central and Northern Asia. The powerful and trained female not only will capture bustards, hares, and foxes but will attack wolves, wild goats, antelopes, and even wild boars. The predominant color of the adult plumage is red-brown or fawn, with an inclination in both sexes to very dark brown or dusky as age advances. Captain Knight's trained golden eagle is already famous in the annals of the modern chase.

Average measurements are as follows: female, length, 35 inches; wing, 27½ inches; tail, 14 inches; tarsus, 3¾ inches; male, length, 32 inches; wing, 24½ inches; tail, 13 inches; tarsus, 3⅞ inches.

For practical purposes, Bonelli's eagle (*Aquila bonellii*), a small, long-legged bird, is the best eagle in which the falconer can invest. It is easier to tame and train and not so unwieldy or capricious as the golden eagle. Its legitimate quarry includes waterfowl among birds, hares and rabbits among quadrupeds.

Harting believes that the Berkut (*Aquila nobilis*), generally regarded as a distinct species and much employed in hunting by the natives of Russian North Asia, is a race of the golden eagle. Others regard it as a variety of Bonelli's eagle; still others as a good species and by them it is called the imperial eagle. Its prey is much the same as that of the first-named bird.

We say little about the three eagles that were employed occasionally by Far Eastern falconers for many centuries, including the Middle Ages:

The imperial eagle (*Aquila imperialis vel heliaca*) is smaller than the golden eagle, the length of the male being only 31 inches, and that of the female 32 or more. Its chief habitat is Turkestan; but it is also found throughout most of Asia. It was also an inhabitant

of southeast Europe. Some authorities regard this bird as a race of *A. chrysaetus*.

The steppe eagle (*A. Nipalensis orientalis* Cab.) is placed by some ornithologists among the hawk eagles. At any rate, this species was employed as a hunter and, according to Radcliffe, has among its varied prey musk deer. It presents a noble appearance—the length of the female reaching an average of 77 centimeters. The color of her adult eyes is a fiery yellow.

The spotted eagle (*A. maculata, clanga vel naevia*) is a North European species whose habitat extends to Northern Asia. The female may reach a length of 66 centimeters; the male is slightly less. The former has a wing spread of 170 centimeters. The predominant adult coloring is dark brown, sometimes almost black; hence the Tartar name, *Karagush* or “black eagle.”

To give some idea of the relative speed reached by birds of prey and other animals, *Natural History* published in its 1937 issue a chart on the subject showing the results of the latest (and most reliable) tests. The duck hawk flew—as timed by a stop watch—180 miles an hour, the golden eagle 120 miles, the great bearded vulture (nose dive) 110, the swallow 106, the canvasback duck 72, the golden plover 72, the swift 68, the European teal 68, the peregrine falcon 62, the mallard 60, the merlin 55, the lanner falcon 48, the kestrel 43, the homing pigeon 45, the green heron 34, the great blue heron 28, the sparrow hawk 25, and the woodcock 13. It is further recorded that numerous other aerial flights greatly surpass avian progression: the airplane makes 440 miles per hour, the female deer fly 614, the male deer fly 818, etc.

Kirke Swann and Alexander Wetmore in their admirable and exhaustive monograph on *Accipitres* (*q.v.*) endeavor to identify medieval names of falcons and supply the systematic synonymy desirable in a comprehensive treatise like the *De Arte Venandi*.

Beginning with the social status of the three chief groups, falcons proper (*Falco*), goshawks (*Astur*), and sparrow hawks (*Accipiter*) provided by the *Boke of St. Albans*, they give us (for persons of every rank) the following list:

Emperor	Eagle	<i>Aquila chrysaetos</i>
King	Gerfalcon and its tercel	<i>Falco rusticolus et candicans</i>
Prince	Falcon gentle and its tercel	<i>Falco peregrinus peregrinus</i>
Duke	Rock falcon	<i>Falco peregrinus peregrinus?</i>
Earl	Peregrine	<i>Falco peregrinus peregrinus, female</i>
Baron	Bastard	<i>Falco peregrinus peregrinus, male</i>
Knight	Sacre and sacret	<i>Falco cherrug cherrug</i>
Squire	Lanare (Lanner) and lanret	<i>Falco biarmicus feldeggii</i>
Lady	Mezlyon (Merlin)	<i>Falco columbarius aesalon</i>
Young man	Hobby	<i>Falco subbuteo subbuteo</i>
Yeoman	Goshawk	<i>Astur gentilis gentilis, female</i>
Poor man	Teccett	<i>Astur gentilis gentilis, male</i>
Priest	Sparrow hawk	<i>Accipiter nisus, female</i>
Holywater clerk	Muskayte	<i>Accipiter nisus, male</i>

The old names of rapacious birds used in falconry are extremely confusing and often difficult to identify, because several supposed “good” varieties of falcons were often birds of the same species. They were races, or were simply used to denote varieties from a particular locality believed to possess special qualifications for falconry. Thus the peregrine falcon figures in the list above several

times as a distinct kind of bird. The "eagle" which heads the Swann and Wetmore list is probably the golden eagle. Three distinct varieties of this *Aquila* were supposed by falconers to exist; these were, according to Guillaume Bouchet (1567), the "Royal Eagle," the "Fulvous Eagle," and the "Black Eagle," which varieties merely indicate stages of plumage.

The imperial eagle has rarely been used in falconry, for the good reason that it is a sluggish bird, lacking in courage, little better in fact than a kite. It also lacks the strength of the golden eagle, especially in feet and claws.

To this list a few other names may be added from French authors on falconry who enumerate the following birds as employed in the noblest of sports:

Faucon blanc	<i>F. rusticolus candicans</i>
Faucon d'Islande	<i>F. rusticolus islandus</i>
Faucon gerfaut	<i>F. rusticolus rusticolus</i>
Faucon sacre	<i>F. cherrug cherrug</i>
Faucon lanier	<i>F. biarmicus feldeggii</i>
Faucon pèlerin	<i>F. peregrinus peregrinus</i>
Faucon de Barbarie	<i>F. pelegrioides pelegrioides</i>
Faucon émerillon	<i>F. columbarius aesalon</i>
Faucon hobereau	<i>F. subbuteo subbuteo</i>
Faucon cresserelle	<i>C. tinnunculus tinnunculus</i>
Faucon cresserellette	<i>C. naumanni naumanni</i>
Faucon aux pieds rouges	<i>F. vespertinus vespertinus</i>
L'autour	<i>A. gentilis</i>
L'épervier	<i>A. nisus nisus</i>
L'alphanet	<i>F. biarmicus feldeggii</i>
L'alèthe	<i>A. gentilis?</i>
Le faucon saphir	<i>F. subbuteo?</i>

As Arnold Fleming in his *Falconry and Falcons* (1934) (p. 10) says: "There was a hierarchy of the sport at the head of which was the sovereign; it was as distinctly aristocratic as heraldry.

"The Tiercel of a Jerfalcon was for a king.

"The Gentle-falcon was for a prince.

"The falcon of the rock was for a duke.

"The peregrine was for an earl.

"The perky Merlin was for Milady.

"The hobby was for a young Squire.

"The Goshawk was for a yeoman.

"The Kestrel was for a knave or servant.

"The Spare hawk was for the clergy or retainer."

Finally, falconry has borne in every age a chivalrous, a spiritual, and, sometimes, even a religious aspect. An echo of such an attitude, or at least a loan of its imagery, is evident in the following quatrains by Helene Vander Poel Sinnott (*New York Times*, April 28, 1938):

MASTER FALCONER

I would plunge from the highest mist
Down to the lowest deep,
Or I would from my Maker's wrist
Vie with the falcon's sweep.

I would know the ecstasy
Of unhooded hunting lust,
A power-drive from sublimity
Down to the groveling dust.

Unerring should my death-cast be—
But, obedient to His nod,
Swift I'd soar to my hood once more
Back to the hand of God.

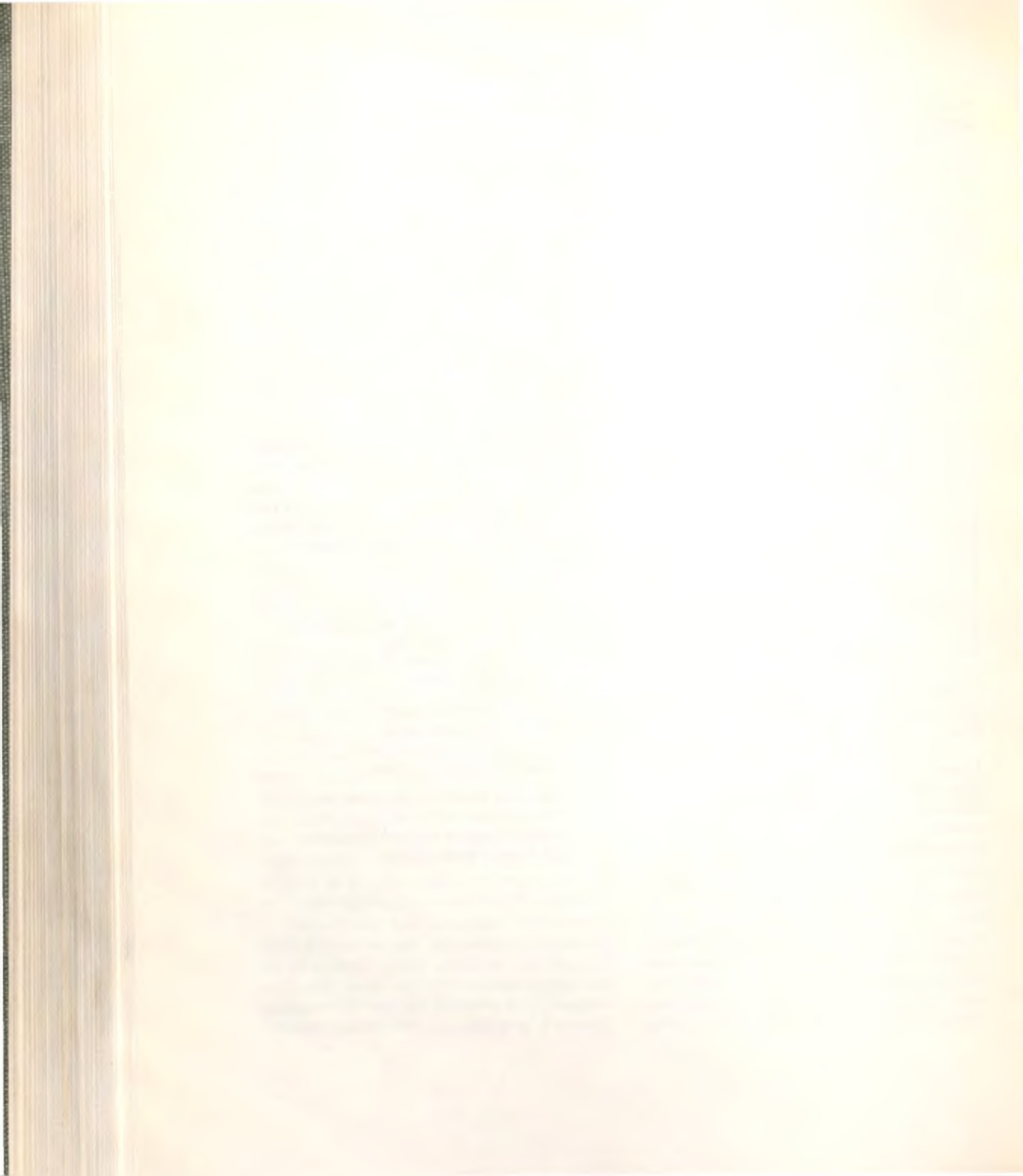



Annotated Roster of Birds Familiar to
Emperor Frederick II



ANNOTATED ROSTER OF BIRDS THAT ARE MENTIONED,
DEPICTED BY, AND WERE PROBABLY FAMILIAR TO
THE EMPEROR FREDERICK II

AND THAT ARE OF INTEREST TO FALCONERS AND OTHER STUDENTS
OF MEDIEVAL ORNITHOLOGY

HE following catalogue is a supplement to (and sometimes contains information to be found in) another chapter of this translation. It might be styled a brief, incomplete, descriptive account of Northern and Mid-European birds, with a sprinkling of Near and Far Eastern avifauna. Many of them were portrayed by order of either Frederick II or (more probably) Manfred in the Vatican Codex of the *De Arte Venandi*, and their portraits appear among the 900 miniatures that (in particular) illustrate the two-book Vatican Codex. The identities of the great majority of these birds have been established by Albertus Magnus, Killermann, Schlegel, Schneider, and others.

Throughout this compilation we have frequently followed the classification chosen by Killermann in his *Vogelkunde des Albertus Magnus*, wherein 115 bird species are stated as having been clearly identified by that contemporary of the Emperor.

Although not a practical ornithologist, Albertus Magnus was a diligent reader and one may at least rely upon the accuracy of his quotations from Pliny, Aristotle, Aelian, and other naturalists, feeling fairly certain that his descriptions of avian species have behind them at least the best ancient and medieval authorities.

The names given to birds impossible of

identification were probably, in most instances at least, vernacular synonyms of common varieties. A few were purely mythical animals; but these, be it noted, are rarely specifically adopted in the *De Arte Venandi*. When not commented upon in the text (in any of the Codices), the imperial author's designation of an avian species or genus is usually given without comment by the translators.

In the present translation only the systematic and common English and Latin synonyms (often not the latest) are quoted, the short definitions of the *Oxford English Dictionary* and *Webster's Unabridged* being freely drawn upon for the purpose.

The Emperor furnishes an avian ecology not to be disregarded; in particular does he discourse—often at some length—on the habits, modes of living, family affairs, and social surroundings of the birds with whom he was acquainted. He even gives us, in several instances, short lists of generic and specific names that one might consider to be an embryonic medieval synonymy.

The reader will also perceive a number of other observations, original with the imperial author, that by many had been regarded as entirely modern.

The words and phrases followed by "L." are quoted exactly as they appear in one or other of the Codices.

More extended accounts of the favorite

hawks employed by the Emperor and his associates are already given under appropriate captions in a special chapter (and elsewhere) in this translation.

There is considerable evidence in the text of the *De Arte Venandi* to warrant the belief that had the versatile author of that treatise lived a few years longer, with leisure at his command, he not only would have completed his literary work by writing the ornithological chapters he promised—and never, so far as we know, finished—but he would have given us also a separate textbook on general ornithology, using, with other drawings, the 900 miniatures of the Vatican Codex as a portion of the illustrations required for such a complete work.

Acantis. See FINCH.

Accipiter. L. Hawk.

Accipiter nisus. See SPARROW HAWK. Similar to the American sharp-shinned species.

Adjutant. See STORK.

Aëriphus falco, of Albertus Magnus. Schneider (*Reliqua Librorum* . . . , pp. 89, 90) discusses the identity of this hawk "with the flame-coloured eyes, thick legs, and head," but he is not sure of its true character. Symmachus, following Vincentius, describes it as having *crura nodosa, pedes crassos, ungues crudeles* . . . *caput et pedes, juga id est* . . . *magna*.

Agicioli. Under this title Albertus Magnus describes, or mentions, a number of small birds, including some of the bee-eaters, the wren, a titmouse, and the redstart. All these birds were known to the author of the *De Arte Venandi*.

Alauda. L. Lark.

Albanus. L. Hobby; compare Italian ALBANELLA.

Alcedo. See KINGFISHER.

Ameriga. See GARDEN WARBLER.

Amsel. See THRUSH.

Anas. L. Duck. Cf. ANAS CAMPESTER (L.), the lesser bustard.

Anas de Faraone. See BRANT. See also footnote 7, page 59.

Anser. L. Goose.

Anseres carbonerae (?). Black goose.

Anseres roserae vel rosetae. L.

Aquila. L. Eagle.

Aquila chrysaetos. Golden eagle. See also EAGLE.

Aquila heliaca. L. Imperial eagle. See EAGLE.

Aquila ignobilis. L. Smaller eagle.

Aquila piscatricis. L. Osprey; fish eagle.

Ardea. L. See HERON.

Ardeola stellaris. See BITTERN.

Asclops. See SNIPE.

Assalon. One of the unidentified birds (probably) known to the Emperor Frederick II and mentioned by Albertus Magnus. The latter describes it "as large as a sparrow, living on leafage and thorn, and an enemy of ravens, foxes, and asses." The Athilon (L.) is probably the same bird.

Astur. See GOSHAWK.

Athilon. See ASSALON.

Auk. It is doubtful whether the great auk, *Plautus impennis*, was known to Frederick II. This flightless and now extinct northern sea bird is not definitely described by any of the early ornithologists. Perhaps the Alcyones of Pliny may have included one of the Alcidae.

Aves glaciei. See KINGFISHER.

Aves paradisi (Aves de Paradiso). L. These are probably not the birds known to modern ornithologists, although Albertus Magnus includes them as Egyptian species, "large as geese." Brown birds resembling jackdaws were also described under one of these titles, migratory in character; but of their origin nothing was known.

Avis lini. See FINCH.

Ayro. L. Heron.

Barnacle Goose; also called **Bernecle, Bernicle, Bernacle.** **Branta leucopris.** A species of wild goose (*Anas leucopsis vel leucopris*) allied to the brant goose, found in the arctic seas, where it raises its young. This bird, of which the breeding place was long unknown, was formerly believed to be produced out of the fruit



PLATE 181.—Tomb of the Emperor Frederick II of Hohenstaufen (d. 1250) in the Cathedral at Palermo.
In this same tomb is buried also Peter II, King of Sicily, the Emperor's great-great-grandson.



PLATE 182.—Portrait of Asaf Khan, Minister of Shah-Jehan.
After a seventeenth-century painter.

of a tree growing by the seashore, or itself to grow upon the tree attached by its bill (whence also called tree goose), or to be produced out of a shell which grew upon this tree, or was engendered as a kind of "mushroom" or spume from the corruption or rotting of timber in the water. These claims were disputed by that scientific skeptic, Emperor Frederick II.

Barn Owl. See OWL.

Bernecla (Bernicla). L. Barnacle goose.

Besardus. L. Merlin.¹

Bistarda. This unidentified species was a bird of prey as large as an eagle, with white wings and tail, that fed on carrion, hares, lambs, etc.—very likely one of the vultures. Perhaps "bustard," given as the English equivalent of *bistardus*, is occasionally incorrect.

Bittern. A genus of grallatorial birds (*Botaurus*), nearly allied to the herons, but smaller. The species *B. stellaris* is a native of Europe and the adjoining parts of the Old World. It is noted for the "boom" which it utters during the breeding season, whence its popular names, "mire drum," "bull of the bog," as well as its scientific designation, *Botaurus*. Aristotle plainly described this peculiar, well-known bird as *Ardea stellaris*; but it was not until late in the Middle Ages that its present genus and specific name acquired recognition. See also HERON.

Blackbird. Merl. A well-known European songbird, a species of thrush, *Merula turdus*, L. Albertus Magnus distinguished between *Turdus* and *Turdella*. The former (probably *Turdus vircivorus*) is a gray bird of small size that builds a nest of mud and leaves. Its incubation period is ten days. This bird perches by preference on clods of upturned earth. Its flesh is wholesome. The second species, also according to Albertus, is the song thrush (*Turdus musicus* Linn.) that sings in the springtime. The color is gray and the breast variegated and yellow.

This bird can easily be tamed, and its flesh furnishes excellent eating. The black thrush or amsel (*Turdus Merula* Linn.) has a beautifully modulated voice, with nine notes in the scale (*modulos et melos edens*). Its mandibles and legs are yellow; its breast is brown. The species Albertus Magnus speaks of is a white amsel, the writer probably being unaware of the albinic variety. He also distinguishes the blue merl (*Monticola cyanus*) and twice refers to it under the synonyms *Passer solitarius* and *Merulus stercosus*. This species is smaller than the amsel, is quite black, lives in old ruins and rocky cliffs, is very musical, and, except during the breeding season, lives quite alone.

Blackcock. The male of the black grouse or black game. See GROUSE.

Blenectae. L. (?)

Botaurus stellaris. See BITTERN.

Brant. (Derivation uncertain.) The smallest species of wild goose (*Bernicla brenta*), breeding in high northern latitudes and migrating southward, chiefly along the coasts. The common European species is *B. brenta*. They are all favorite game birds. The snow goose and the blue goose, of the genus *Chen*, are also called white brant and blue brant, respectively.

Branta leucopris. See BARNACLE GOOSE.

Brent Goose. See BRANT.

Brobuxen. See BUZZARD.

Bubo maximus. *Huanus*. Eagle owl. Great horned owl. A nocturnal bird of prey, the largest of the horned-owl tribe, inhabiting Europe and North Asia. It is well described by Pliny, Aristotle, and other early naturalists. Probably it is the "devilbird," so called from its horrible, demoniac, nocturnal screams, resounding throughout the jungles of India and Ceylon.

Bustard. A genus of birds (*Otis*) presenting affinities to both the *Cursores* and the *Grallatores* or waders; remarkable for their great size and running powers. The great bustard (*Otis tarda*) is the largest European bird, formerly abundant. The common bustard is *Buteo vulgaris*. See also BUZZARD.

¹ Speaking of the food of certain raptures, the author of *De Arte Venandi* says: *quaedam utuntur muribus campatribus, lacertis, ranis, scarabeis, brucis . . . ut ille aves quae dicuntur albanis et ut ille quae dicuntur besardi et clisterelle.*

Buzzard. Name for the genus *Buteo*, birds of the falcon family, e.g., *B. vulgaris*; applied, also, to other birds of the Falconidae: as, BALD BUZZARD; the OSPREY, *Pandion haliaetus*; HONEY BUZZARD, *Pernis apivorus*; and MOOR BUZZARD, *Circus aeruginosus*.

The buzzard is an inferior kind of hawk, useless for falconry; hence "a worthless person." Albertus Magnus gives the vernacular synonym of *brobuxen* for *Buteo vulgaris*.

Calandra Lark. Callandra. L. See LARK.

Capercaillie. Capercaillie. Cock of the wood. Black cock. The largest European grouse (*Tetrao urogallus*), found in many of the wooded districts of Europe and Asia. It feeds on berries, worms, and pine shoots, which give the flesh a strong flavor. The male bird reaches twelve pounds or more in weight, and is largely dark gray and black in color. The female is much smaller, with mottled plumage.

Cardellus. Cardillus. Goldfinch.

Caristae. These are, with little doubt, mythical birds, whose existence was never admitted by the Emperor.

Choretas. This species has not been diagnosed by any medieval authority. It seems to have been "an enemy of the crows and ravens" (Albertus Magnus).

Ciconia. L. Stork.

Cinnus (Cygnus). L. Swan.

Circella. L. Teal.

Clisterella. L. Kestrel.

Cofanus (Pellicanus). L. Pelican.

Collinus (Corlinus). L. Curlew.

Columba. L. Pigeon or dove.

Columba de Syria. L. Tumbler pigeon.

Colymbes vel podiceps cristatus. L. See GREBE.

Coot. Water hen. Gallinule. Water rail. Any of certain birds of the rail family (Rallidae) constituting the genus *Fulica*. The coots are more duck-like in shape, plumage, and habits than the rest of the family and have lobes along the sides of the toes. They are stupid and fly slowly, and can hardly be classed as game birds. The common coot of Europe is *F. atra*.

Although known to early writers, the best medieval description of the coot is given by Phabanus Maurus. Albertus Magnus merely mentions the species in his chapter on the duck as a *pullus aquaticus*.

Cormorant. A large, voracious sea bird (*Phalacrocorax carbo*), about three feet in length and of a lustrous black color, widely diffused over the Northern Hemisphere and found on both sides of the Atlantic. There are about twenty-five species, some of which are found in all maritime parts of the world. One of the cormorants was described by Aristotle, while Albertus Magnus has given us an account of other species, all of which were very likely familiar to the author of the *De Arte Venandi cum Avibus*. Some kinds, *P. carbosinensis*, for example, found in China, and *P. capillatus*, in Japan, are used for catching fish, a band being placed about the throat so that they cannot swallow the prey.

Corn Crake. Land rail. A common European short-billed rail (*Grex grex*) which frequents grain fields.

The species is mentioned by several medieval writers and was probably well known to the Emperor.

Corniculus. L. Little crow.

Cornix. L. Crow.

Corvus vel garrulus glandarius. L. See JAY.

Corvus marinus. L. Cormorant.

Cosardus (Coyardus). L. (?) Wood lark.

Costardi. L. See GOSTURDI.

Coturnix. L. Quail.

Crane. *Grus cinerea* is the common European crane. These birds of the family Gruidae form a small group of tall, wading birds superficially resembling the herons, with which they are popularly confused; but structurally they are more nearly related to the rails. The plumage is compact; head partly naked; bill obtuse, with large nostrils near the middle of the upper mandible; hind toe elevated.

The early writers, including Aristotle, Pliny, and Homer, fully describe these well-

known birds, sometimes mistaking the herons for them, although as a practiced hunter the author of the *De Arte Venandi* clearly distinguishes the species. Albertus Magnus gives considerable space to a discussion of their natural history. See also HERON and RAIL.

Crecca. See TEAL.

Crested Lark. Cozardus. See GALERITA CRISTATA.

Crochilus. Regulus. L. See WREN.

Crossbill. *Loxia curvirostra* Linn. Under the heading "Facator" Albertus Magnus probably describes this variety of finch. The bird, says he, incubates in winter, when the embryos or nestlings frequently die, but in more favorable weather they survive, an observation that seems to point to an Oriental species and not to a northern *loxia*.

Crow. Various species of large, glossy black, oscine birds, widely distributed throughout Europe and elsewhere. They are highly intelligent and, on the whole, belong to the class of "beneficial birds." The ordinary form is *Corvus brachyrhynchus*. Albertus Magnus describes: the hooded crow (*C. cinereus*), half black and half gray; the rook (*C. frugilegus* Linn.), under the name *graculus*, of which he gives a clear and extended account; and the jackdaw (*q.v.*), *C. monedula* Linn. The last-named receives the appropriate vernacular title *monetam tollens*, owing to his thieving propensities. This bird may also learn to speak a few words and phrases.

Other members of the crow family that were more or less known to the Emperor are the so-called nutcracker (*Nucifraga caryocatactes* Briss.), unknown to Albertus Magnus; also the mountain daw (*Monedula montana*), the northern rock crow (*Fregilis graculus* Cuv.), and the Alpine crow (*Pyrrhocorax alpinus* Vieill.) of Pliny. Finally, Albertus Magnus describes a corvine species, unknown to Aristotle, the ground crow (*Corvus terrenus*).

Cuckoo. This familiar European bird was well known to the ancients; often mentioned by Albertus Magnus. It is noted for its two-note call, its grayish-brown color above, barred

white below, and its habit of laying its eggs in the nests of other birds. *Cuculus canorus* Linn. is the common European species. Both Pliny and Aristotle had difficulty in placing exactly this species among its fellows, as it had to them the qualities of both the sparrow and the pigeon. Long discussions of this moot question are found in these authors. No doubt they attracted the attention of such an acute observer as the Emperor.

Curlew. Thick-knee. A name for any bird of the genus *Oedicronemus*, especially the stone curlew or Norfolk or great plover, *O. scolopax* (*O. crepitans* Temmink). Its vulgar name derives from the enlargement of the tibiotarsal joint. See also THICK-KNEE. The titles CURLEW and STONE PLOVER are also conferred on any of a number of large-sized birds of the family *Scolopacidae* having long legs, long, slender, downwardly-curved bill, and plumage variegated with brown and buff. They constitute the genera *Numenius* and *Phaeopus*. The common (large) species of Europe is *N. arquata*; the smaller species, or whimbrel, is *P. phaeopus*. Locally, as in parts of Great Britain, it is called ordinarily stone curlew. These and allied species were known under a variety of names to medieval naturalists.

Darter. Snakebird. A fish-eating, cormorant-like, web-footed bird of the pelican tribe, with long neck and small head, found in parts of tropical Africa and elsewhere, so called from its habit of darting at its prey. Although not mentioned by Frederick II, this species was probably known to him.

Diomedes. A species (of course *not* the Linnæan albatross) of doubtful characteristics. It may have been *Herodius egretta* Boie. It was described by Albertus Magnus as entirely white, large as a swan, and having a sharp-pointed beak.

Diver. See LOON.

Dotterel. See STONE PLOVER.

Dove. Fatha. Faca. Pigeon. Any of numerous birds of the family *Columbidae*. Dove and pigeon are practically synonymous, but in ordi-

nary usage pigeon is a somewhat broader term used of all the Columbidae. To the domestic pigeon and to various wild species both terms are applicable, but dove designates specifically many of the smaller species of the family, as turtledove, mourning dove, ground dove, etc.—serving to distinguish them from larger forms to which pigeon is more or less exclusively applied. The accounts given by Aristotle and other early writers of this interesting family furnish attractive reading. The birds must have been favorites with Frederick II, as numerous species were the regular food of his hawks. See TURTLEDOVE.

Driacha. Unknown species; probably one of the swallows, as claimed by Albertus Magnus.

Duck. An avian race referred to frequently by Frederick II, who mentions in particular the mallards.

Eagle. The name commonly given to any of the larger diurnal birds of prey that are not vultures, though some species that are smaller than certain buzzards are by ornithologists accounted eagles. They are noted for their strength, size, graceful figure, keenness of vision, and powers of flight. Although some species are members of different genera of the family Falconidae, the typical eagles constitute the genus *Aquila*, of which the legs are feathered to the toes. The most-noted European forms are the golden eagle (*Aquila chrysaetos* Bp.), the imperial eagle (*A. heliaca*), the European sea eagle (*A. albicilla*), and the harpy eagle (*Harpia harpyia*). The figure of the eagle, as the king of birds, is commonly used as a heraldic emblem, also for standards and other emblematic devices. The terrestrial eagles all feed on live birds and smaller mammals. Albertus Magnus definitely describes a large black species with yellow feet, long, strong talons, widespread wings, and straight tail feathers, undoubtedly the golden eagle. A smaller bird, with predominant white and gray coloration whose terminal feathers (of a shorter wing) were white, is *Haliaeetus albicilla* Grey. Albertus Magnus also furnishes an account of a third hunting bird that we know as *Aquila truncorum*, the tree eagle, and a fourth, *A. naevia* Buss.

The osprey (*q.v.*), or sea eagle, was also well known in medieval times. All the eagles employed in falconry are further described in a special chapter of this translation.

Eagle Owl. *Bubo maximus.* See UHU.

Egirthus. See FINCH.

Eleonora Falcon. See SAKER FALCON, and the special section above on "Frederick II and His Favorite Birds of Prey."

Faca. See DOVE.

Facator. Unidentified bird, probably a crossbill (*q.v.*).

Facha. L. Ringdove.

Fakecha (Facheta). L. Ringdove.

Falco. L. Falcon.

Falco gentiles absolute. L. Noble falcon.

Falco gentiles peregrinus. L. Peregrine.

Falco lanerius. L. Lanner.

Falco laynerius. L. Lanner.

Falco sacer. L. Saker.

Falco subbuteo. See HOBBY.

Falco tinnunculus. See KESTREL.

Falcon. According to Albertus Magnus this name includes rapacious birds with a comparatively short neck and mandibles, wide chest, prominent sternum, long wings, contracted tail, and shorter legs than other hunting birds. Feathers are black and white, at first reddish, later in life whitish, eyes and feet are yellow. These important species, favorites of Frederick II, are fully described elsewhere in the present translation. (See pp. 508-19 and pp. 526-27.) See also HOBBY, LANNER, PEREGRINE, TREE FALCON, SAKER.

Fasianus (Fagianus). L. Pheasant.

Fatha. *Faca.* L. See DOVE.

Fetix. This bird, whose positive identity is lacking, is said by Albertus Magnus to incubate twice in summer, when it hatches many nestlings. It is small and short-lived.

Ficedula. The only description Albertus Magnus gives of this bird, "known to the Emperor," is that it eats fish.

Finch. Technically, this term includes any of the very large family Fringillidae—the sparrows, grosbeaks, linnets, goldfinches, crossbills, buntings, *et al.* They are generally small birds, good songsters, with thick, strong mandibles adapted to their (hard) seed-eating habits. Albertus Magnus divides finches into three categories: The first is gray with yellow sides and reddish head. The second class is described as smaller than the first and yellow-green in color. The siskin (*Fringilla spinus* Linn.) is a sample of this variety. The third class has a flame-colored breast, of which *F. coelebs* Linn. is an example. Other authorities add a fourth variety called *avis lini* because the bird is fond of flaxseed; it has a gray back and a saffron-colored breast. Aristotle adds to this list the *acantis*, a race the size of a sparrow, feeding on grass seed and nesting in thorny thickets. This is probably *F. linota*. Another finch is the bird called *Egirthus*.

Flamingo. This species (*Phoenicopterus ruber* Linn.) was familiar to the ancients and known to Aristotle as *porphyrio*. The tongue of this curious, long-legged, long-necked wader was in former centuries regarded as an unusual delicacy, the best specimens coming from the Balearic Islands.

Flycatcher. **Muscicapa.** Any of numerous passerine birds that feed on insects taken on the wing. The true flycatchers of the Old World are oscine, and belong to the family Muscipidae, such as the spotted flycatcher (*M. striata*). Albertus Magnus included in his list of flycatchers a bird the size of a pigeon, with a weak flight, that was probably a nightjar.

Francolin. **Francolin Partridge.** Any of numerous partridges from Southern Asia and Africa, constituting the genus *Francolinus* and allied genera. *F. francolinus*, called the black partridge from the dark plumage of the male, formerly inhabited all of Southern Europe, but is now confined to Cyprus, and countries further east. It is also found in Asia Minor. See PARTRIDGE.

Franquillus. L. Francolin.

Fringilla cardinalis. See GOLDFINCH.

Fulex. L. Coot.

Fulica. L. Coot.

Galeranus niger campester. L. Black vulture.

Galerita cristata. See COZARDUS and CRESTED LARK.

Gallina. L. Gallinule (?).

Gallina de India. L. Indian jungle fowl (?)

Gallinule. See COOT.

Gannet. The Solan goose (*Sula bassana*). The adult of the common gannet, from the North Atlantic, is white, with a yellowish tinge of the head, and black primaries. It has about six feet of wing spread. The bird is a strong and expert flier, catching fish by plunging after them into the sea; it breeds in colonies on cliffs and rocks. This species was certainly known to the author of the *De Arte Venandi cum Avibus*.

Garden Warbler. **Whitethroat.** This bird (one of the *Sylvia*) is, with the wagtail (*Motacilla*) and the yellowhammer (*Amberiza*), catalogued by Albertus Magnus among the most melodious of the songsters. The last-named is quoted also under the synonyms *amerika* and *gursa*. All these and the allied species were certainly well known to Frederick II.

Gerfalcon. **Girofalcon.** **Gyrfalcon.** A name at one time confined to the large falcon that was early trained to fly at herons; now, any large falcon of the arctic regions of Europe, Asia, and America. These fine birds constitute the subgenus *Hierofalco*, e.g., *Falco rusticolus* of Europe, the *F. rusticolus islandus* of Iceland and Northern regions, and the *F. rusticolus uralensis* of Asia. They are about two feet long, and more powerful, though less active, than the peregrine falcon. Individuals vary greatly in coloration, from the very dark-colored, as in the black gerfalcon (*F. rusticolus obsoletus*), to almost pure white, as in the white gerfalcon (*F. rusticolus candicans*), with only a few dark markings. Frederick II devotes nearly the whole of Book IV to these famous birds. See pp. 509–10 on the subject.

Girofalcon. L. Gerfalcon.

Girofalcon. See GERFALCON.

Glutis. A species known to the author of the *De Arte Venandi* but so far not identified. It is

said to be "slow in its movements." Consult Albertus Magnus.

Goatsucker. Nightjar. The former name was given to *Caprimulgus europaeus* from a belief that it sucks the udders of goats; the designation was applied also to other birds of the same genus. The goatsuckers are mostly medium-sized, long-winged, nocturnal or crepuscular birds, with a short bill but wide mouth, short legs, and soft, mottled plumage. They feed on insects, which they take when on the wing.

These birds were known to both Pliny and Albertus Magnus but were confounded by them with the owls and blackbirds.

Godwit. See STONE PLOVER.

Goldfinch. Brachyotus. Yellowhammer. A well-known, bright-colored songbird (*Carduelis elegans*) of the family Fringillidae, with a patch of yellow on its wings. It is fully described by Albertus Magnus. See also FINCH.

Goosander. See MERGANSER.

Goose. A general name for large, web-footed birds of the subfamily Anserinae (family Anatidae), usually larger than a duck and smaller than a swan, including *Anser* and several allied genera.

The word is usually applied to the common tame goose (*Anser domesticus*), descended from the wild gray or graylag goose (*A. ferus vel cinereus*). Other and numerous species are distinguished by differences in color, appearance, or habits, as black, blue-winged, laughing, pink-footed, white-fronted; also as to habitat, fen-, marsh goose, etc. See also BARNACLE GOOSE, BRENT GOOSE, and BRANT. Albertus Magnus devotes much space to the various species, listing in all six varieties or classes of geese, founded mainly on the teachings of older naturalists. Doubtless all of these were familiar to the author of the *De Arte Venandi*.

Goshawk. Astur gentilis. A large, short-winged hawk, which with *Astur palumbarius* Bechst., as well as other and similar hawks, constitutes the genus or subgenus *Astur*. They are noted for their powerful flight, activity,

and courage, all of which are fully considered elsewhere in this translation.

Gosturdi (Costardi?). Buzzards? These unidentified birds, mentioned several times by Frederick II, are said to be clay-colored, to incubate on the ground, and to fly low down. Their young are said in folklore tales to be of reptilian origin, but brooded and fed by the old birds.

Graculus. See CROW.

Grebe. Diving birds of the genus *Podiceps*, characterized by a short body, flattened and lobed feet, and almost entire absence of tail. They are expert divers and able to swim long distances under water. The nest is built of reeds, etc., close to or even floating on the water. Among the larger species are the red-necked grebe (*Colymbus grisegena*) of Europe and *C. grisegena holboelli* (Holboell's grebe) of Eastern Asia; also the crested grebe (*C. cristatus*), which has a large, bifurcated crest and is widely distributed in the Old World. The horned grebe (*Colymbus auritus*) is a common, small-crested species of the Northern Hemisphere. These water birds were probably familiar to the Emperor.

Grouse. Gray Hen. Hazel. Hazel Hen. Any gallinaceous bird, having feathered feet, of the family Tetraonidae.

The reddish-colored game bird *Lagopus* (formerly *Tetrao scoticus*) is more particularly called red grouse, also commonly known as the moor game.

Besides the red grouse, we have many other varieties. Both Pliny and Albertus Magnus describe these game birds, which doubtless were also well known to Frederick II. The former gives a good account of *Lagopus mutus*. See CAPERCAILZIE.

Grus. L. Crane.

Gryphes. These are the fabled "griffins," of mythical origin and not claimed by any medieval authority as representing living species.

Gull. This species is, broadly, a web-footed, long-winged aquatic bird of the numerous family Laridae. They differ from the terns (*q.v.*) in their larger size, stouter build, hooked bill, and short, unforked tail. Their food is (dead) fish

and offal, in which respect they are useful scavengers. The family name *Larus* was furnished by Aristotle, of which three distinct forms are described by Albertus Magnus, among them the common gull (*L. canus* Linn.).

Gursa. See GARDEN WARBLER.

Harpy Eagle. *Harpia harpyja*. See EAGLE.

Harpyen. Unidentified species, perhaps mythical. Possibly they were petrels.

Hawk Owl. See OWL.

Hazel Hen. See GROUSE.

Hematopus. See OYSTER CATCHER.

Hen. The female of the common domestic or barn-door fowl (*Gallus domesticus* Briss.), the male of which is the cock, as well as of most gallinaceous birds. See GROUSE.

Heron. The name of a large natural group of long-necked, long-legged wading birds, belonging to the genus *Ardea* or family Ardeidae; especially and primarily, the common or gray heron of Europe, *Ardea cinerea*.

These birds have a long neck and legs, a long, tapering bill with a sharp point and sharp cutting edges, large wings, and soft plumage. The inner edge of the claw of the middle toe is pectinate. Some species exhibit dichromatism, and many develop special plumes during the breeding season. Herons chiefly frequent the vicinity of water and feed mostly on aquatic animals, which they capture by quick thrusts of their sharp bill. They usually nest in trees (though the bitterns are exceptions to this rule), often in communities called "heronries." The young are helpless when hatched. The different varieties vary much in size, but none are as large as some of the cranes (see CRANE), with which they are often popularly confused.

Hérons, famous in the annals of falconry, were naturally well known to the author of the *De Arte Venandi*, and considerable space is devoted to them by the Emperor.

Hirundo. L. Swallow.

Hobby. Tree falcon, *Falco subbuteo*. A small species widely distributed throughout the Old World. This bird was formerly trained for hawking and flown at small birds such as larks.

Its relation to practical falconry is fully considered in this translation.

Honey Buzzard. A bird of prey of the genus *Pernis*, especially the European species, *P. apivorus*, which feeds chiefly on the larvae of bees and wasps.

Hoopoe. A member of the family Upupidae. The typical form is *Upupa epops*, a Southern European species, conspicuous by its variegated plumage and its large, erectile crest. It is a pretty bird, has the size of a large thrush, with cinnamon-colored and black plumage, but it is filthy in food and habits. The species was well known to Aristotle and of course to our author. It was widely distributed throughout Asia and at one time all over Europe.

Huanus. L. Long-eared owl. *Chat huant*, Fr.

Iayus. L. Jay (?)

Ibis. A genus of large, grallatorial birds of the family Ibididae, allied to the stork and heron, comprising numerous species with long legs and longer, slender, decurved bill, inhabiting lakes and swamps in warm climates. A bird of this genus is the sacred ibis of Egypt (*Ibis religiosa*), with white and black plumage, an object of veneration among the ancient Egyptians.

Another species is the glossy ibis (*Ibis vel Plegadis falcinellus*), widely distributed in the Old World. The Egyptian ibis was undoubtedly familiar to the Emperor. It is depicted as one of the miniatures in the Vatican copy of the *De Arte Venandi*.

Ibor. A species not identified; it attacks horses, according to Albertus Magnus.

Incendula. An unidentified species, probably one of the Corvidae. It is a foe of the owl (Albertus Magnus).

Jackdaw. The common name of the daw (*Corvus monedula*), one of the smallest of the crow family. It frequents old buildings and church towers, is easily tamed and taught to imitate the sound of words, and is noted for its loquacity and for its thieving propensities.

Jay. Blue Jay. The name of a common European bird, *Garrulus glandarius*, in structure and noisy chatter resembling the magpie but in

habits arboreal, having a plumage of striking appearance, in which vivid tints of blue are heightened by bars of jet black and patches of white. This bird of iridescent coloration was well known to Aristotle and other ancient naturalists as well as to Frederick II.

Karkolix. An unidentified bird, perhaps a cuckoo.

Kestrel. A species of small hawk (*Falco tinnunculus* vel *Tinnunculus alaudarius*); also called "windhover," from its habit of sustaining itself in the same place in the air, with its head to the wind. The name is extended to about fifteen Old World species of the genus *Tinnunculus*. Its use in falconry is discussed elsewhere in this translation (p. 518).

Kingfisher. Any member of the family Alcedinidae, found all over the world. Most of them are crested and bright colored, with a short tail, long, stout beak, and weak feet. Their habit is to sit quietly on a perch, whence they dart out at their prey—insects, small reptiles, and fish—plunging into the water for their piscine food. Both Aristotle and Albertus Magnus wrote about their resplendent beauty, the latter referring to them as *aves glaciei*, "birds that reflect the light like glare ice."

Kiril. Poorly defined bird of prey. Mentioned by Albertus Magnus.

Kite. A bird of the family Falconidae, having long wings, tail usually forked, and no tooth in the bill. Albertus Magnus recognizes in particular the royal kite (*Milvus regalis* Cuvier). These birds are noted for their graceful and sustained flight. Their feet are weak and adapted for taking only such prey as insects or small reptiles. They also feed on offal, and some species are well known as scavengers, e.g., the common European kite (*Milvus milvus*), a rather large species with the plumage chiefly reddish brown, and the pariah kite (*M. migrans govinda*) of India. The black-shouldered kite (*Elanus caeruleus*) is a species widely distributed in Africa.

Kofanus vel Cofanus. See PELICAN.

Komor. An unknown species said to incubate five or six times a year (Albertus Magnus).

Kychramus. See QUAIL.

Lagnales. These Far Eastern species, unidentified, are "very large, black-legged and live on fish" (Albertus Magnus).

Lagopus. See PTARMIGAN; GROUSE.

Lammergeier. The bearded vulture, *Gypaetus barbatus*. This is the largest (extent, 10 feet) European bird of prey. It inhabits lofty mountains in Southern Europe, Asia, and Northern Africa, and has a bristly, beard-like tuft on the chin that furnishes its vulgar name. It resembles both the eagles and the vultures. This species has never been employed in falconry, and was well known to the early ornithologists.

Land Rail. See CORN CRAKE.

Lanarius. L. Lanner (Falcon), *q.v.*

Lanner. A very important species of falcon (*Falco lanarius* vel *F. felddeggi*), found in countries bordering on the Mediterranean. In falconry the female is the lanner of the species, the lanneret is the male. Both forms are in this translation often mentioned as widely employed birds of the chase.

Lapwing. Peewit. A well-known bird of the plover family, *Vanellus vulgaris* vel *cristatus*, common in temperate sections of the Old World. Its upper parts, including the crest, are bronzy green, the throat is black, and the sides of the head and neck and most of the underparts are white. See also SNIPE.

Lark. A name used generally for any bird of the songster family Alaudidae, but usually signifying, when used without a prefix, the skylark (*Alauda arvensis*). Larks have a sandy-brown plumage, and remarkably long hind claws. They inhabit mostly Europe, Asia, and Northern Africa. Under the name *Alauda* Albertus Magnus describes four species that he praises for their musical notes "sung in warm and pleasant weather." The first of these is evidently *G. cristata*, the second *Alauda arvensis*, the third the woodlark, *A. arborea* Linn., and fourth the Calandra lark, *A. calandra*.

Larus. See GULL.

Laynerius. L. Lanner.

Livercini. See SNIPE.

Locust Hawk. *Asturina polyzona*. See ZE-LEUCIDES.



PLATE 183.—Corner tower of the Fortress of Lucera, rebuilt by Charles of Anjou in 1281.

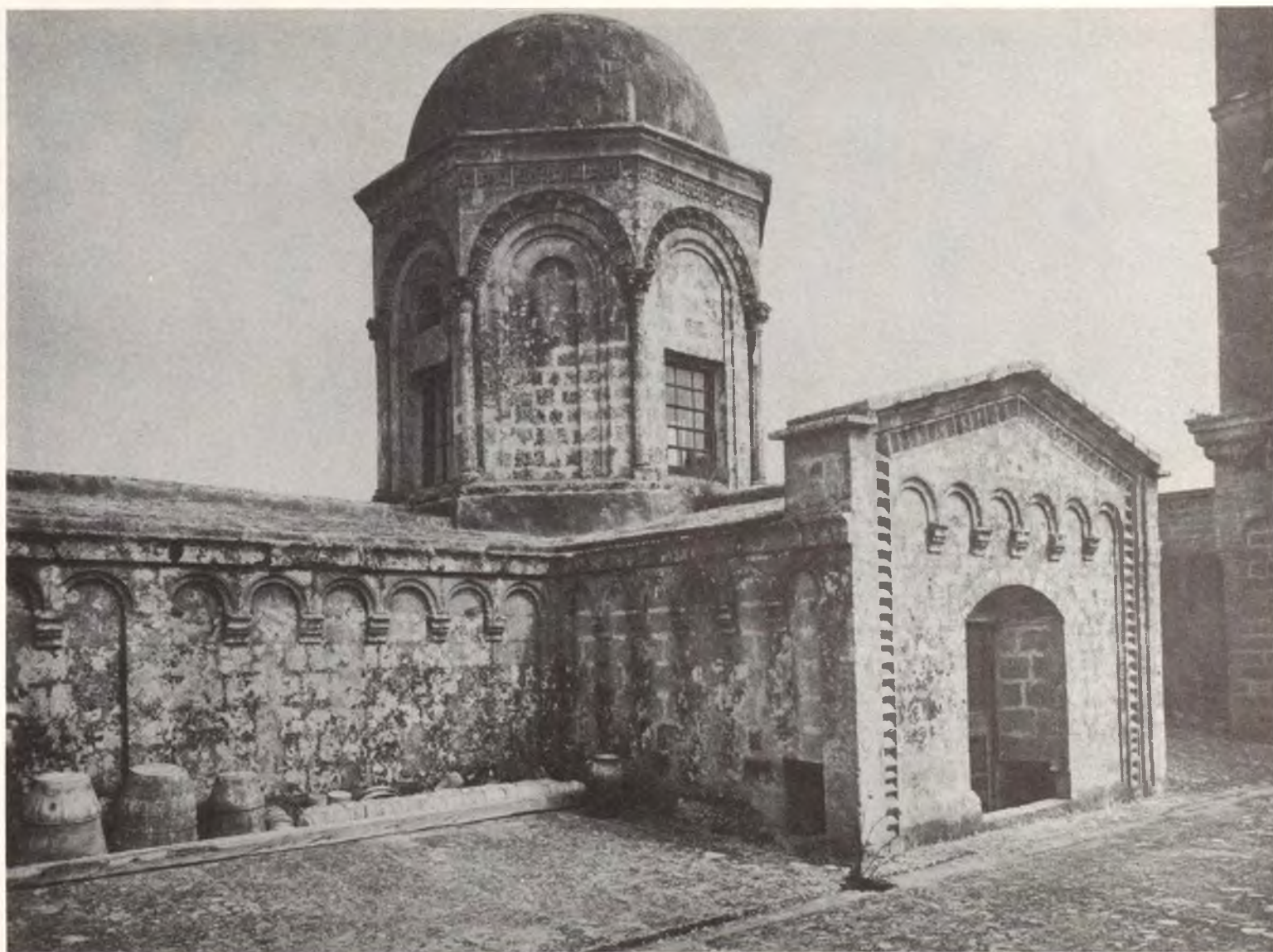

PLATE 184.—Church of Saints Nicolo e Cataldo, Lecce; said to have been founded by Tancred, Count of Lecce (See L, p. 487).



PLATE 185.—Vestibule of the Palace of La Zisa, Palermo, built by William I, showing the characteristic Saracenic stalactite vaulting, mosaic frieze with palms, peacocks, and bowmen. A further Arabic touch is the wall fountain flowing from beneath the Imperial eagle over a marble inclined plane carved geometrically to produce a sense of volume and to increase the apparent rippling of the water.

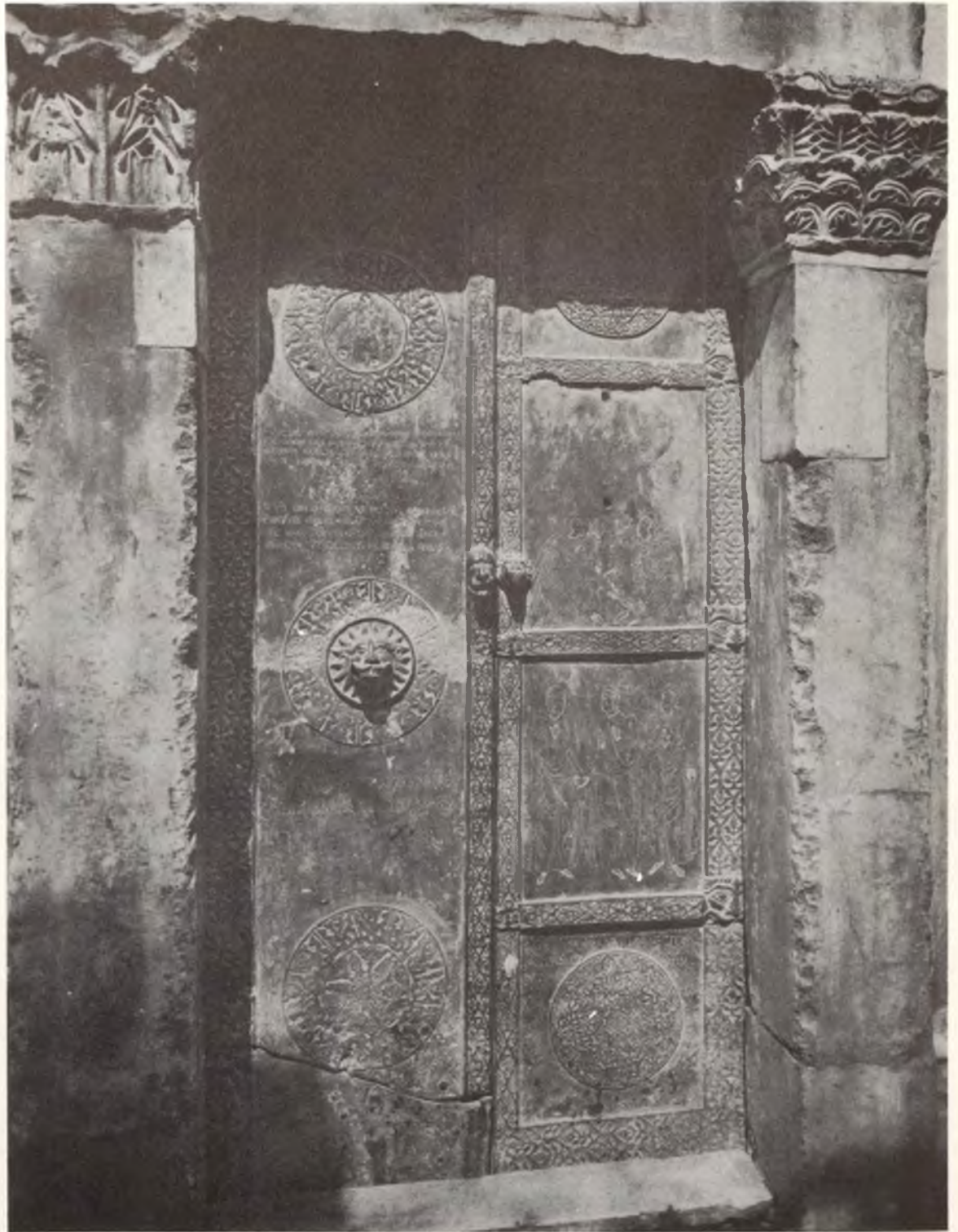

PLATE 186.—Tomb of Bohemond, Prince of Antioch (1056–1111); with bronze doors executed by Roger of Melfi, at Canosa in Apulia.

Loon. Diver. Any of several fish-eating diving birds of the genus *Gavia*, order Galliformes, found in the northern part of the Northern Hemisphere. The common loon, or great northern diver (*Gavia immer*), is nearly three feet long, and has, when adult, an iridescent, black head, white-spotted black back and wings, and white underparts. As elsewhere stated, Albertus Magnus probably described this species as well as other divers, all of which were known to Frederick II.

Lucidae. Unidentified birds, said to be "luminous at night."

Magpie. A common European bird (*Pica caudata* Ray) of the family Corvidae, having a long pointed tail and black-and-white plumage. It is well known for its noisy chatter. It is often taught to repeat a few words; its habits of pilfering and hoarding are proverbial, and it is popularly regarded as a bird of ill omen.

Malirtius. This species was familiar to Frederick; it has been fully described by Albertus Magnus.

Mallardus. L. Mallard.

Marlardus. L. Mallard duck.

Mavis. See THRUSH.

Melantorius. Probably a synonym of the cave or barn swallow. Consult Albertus Magnus.

Merganser. Goosander. **Mergo.** Any bird of the genus *Mergus*, fish-eating ducks of great diving powers, with long, narrow, serrated bill (hooked at the tip), inhabiting northern parts of the Old World. *Mergus merganser* is the common variety; *M. serrator* is the red-breasted merganser. Albertus Magnus devotes three chapters to this bird and its allied species, including the eider duck and (probably) the great northern diver, *Gavia immer*.

Mergo. L. Diver. Merganser (?)

Mergus serrator. See MERGANSER.

Merulus. L. Blackbird.

Milan. See KITE.

Milvus. L. Kite.

Milvus ater. See KITE.

Muscipia. See FLYCATCHER.

Nightingale. Philomel. **Luscinia.** A small, reddish-brown or tawny migratory bird (*Mo-*

tailla luscinia or *Daulias luscinia*), celebrated for the melodious notes which the male utters by night as well as by day during the breeding and nesting season. The common species is about six inches long, russet-brown above, with the rump and tail lighter and the underparts whitish. An inhabitant of Eastern Europe (*Luscinia luscinia*) is similar, but larger. See also THRUSH.

Nightjar. See GOATSUCKER.

Night Owl. See UHU.

Noctua. L. Little horned owl.

Numenius arquata. Stone Curlew. Thick-knee. Three-toed Stone Plover. See CURLEW.

Oedicnemus. See NUMENIUS ARQUATA.

Oriole. Oriole, *Oriolus galbula* Linn. Although Pliny briefly mentions this beautiful, bright yellow bird, Albertus Magnus was the first medieval writer to describe it fully. Its wings and tail are, in sharp contrast to the rest of the body, deep black. An allied species (*Oriolus kundoo*) is found in India and may have been known to Frederick II. Albertus Magnus uses the term *Pirol* to designate not only the orioles but also other (unrelated) species.

Ortygometra. See QUAIL.

Osprey. A large, diurnal bird of prey, *Pandion haliaetus*, frequenting rocky seashores and borders of lakes, preying upon fish; also called sea eagle, fishing eagle, and fish hawk. It builds a bulky nest, placed in a tree or on the ground, often occupied year after year. The osprey is a gentle bird and, when protected, often nests close to human habitations. It is found in most countries and was well known to the ancients, but it was never used in the chase.

Ossa fragus. L. Lammergeier.

Ossifragus. L. Lammergeier. Bonebreaker.

Ossifragentis. L. Lammergeier.

Ostrich. African Ostrich. A very large, ratite bird, *Struthio camelus*, the only species of the genus, inhabiting the sandy plains of Africa and Arabia. It is the largest of existing birds, attaining a height of six or eight feet and a weight of three hundred pounds. Ostriches are

very swift-footed, but their wings are small and useless for flight. The head and neck are downy, the body is covered with soft feathers, the thighs are nearly bare, and the feet are two-toed. In the male the body plumage is black and the wings and tail are white. The female and young male are grayish. The value of its plumes has led to its domestication. Aristotle is among the early authors that give a fair account of this remarkable bird, which was well known to the Emperor and is mentioned in the *De Arte Venandi*.

Otus (Otus) tetrax. Many owls including the species *Otus* (Aristotle, Othus, Strix, and others) were recognized by Albertus Magnus and by the author of the *De Arte Venandi*.

Owl, Barn. Screech Owl. An owl (*Tyto alba*, syn. *Strix flammea*), whose plumage is mottled with buff-brown and gray above and chiefly white below, that frequents barns and other buildings. It occurs, or is represented by, closely related forms throughout most of the world. It was familiar to ancient writers. See EAGLE OWL.

Owl, Hawk. Strix palustris. A diurnal bird that seeks its prey in the daytime. The same vulgar name is also given to the short-eared owl, *Asio brachyotus*.

Oyster Catcher. A vernacular epithet given to certain wading birds of the genus *Haematopus*. They are from 16 to 20 inches long, and their stout legs and heavy, wedge-shaped bills are usually pinkish or bright red. The common species of Europe, Asia, and Northern Africa (*H. ostralegus*) has black and white plumage. The black oyster catcher (*H. bachmani*) of the North Pacific coast is entirely brownish black. Although probably known to Frederick II, this bird is not definitely described by Albertus Magnus.

Palumbus torquatus. See RINGDOVE.

Parrot. Papagei. Papagalio. Any bird of the order Psittaciformes, including the parakeets, cockatoos, macaws, lorries, lorikeets, lovebirds, and their allies. They inhabit the tropics of the world. Some of them were well known in Europe as importations from Eastern coun-

tries. Albertus Magnus fully describes several, e.g., *Palaornis torquatus*. Their most distinctive characters are a naked cere, a stout, curved, hooked bill, the upper mandible of which is movably hinged to the skull. Many are crested, and their coloration is often variegated. Old World species are of rather stout forms with a short square tail, as in the African gray parrot. Parrots are excellent and intelligent mimics, and some readily learn to simulate laughter, crying, and singing, and to enunciate and understand words and long phrases.

Partridge. A gallinaceous game bird of *Perdix*, *Caccabis*, and allied genera. The best-known European species are *Perdix perdix*, the Greek variety, *Caccabis saxatilis*, and the red-legged *C. rufa*.

They are all stout, medium-sized birds of variegated plumage, with short neck, legs, wings, and tail. Pliny and Aristotle discuss the natural history of and accurately describe *Perdix cinerea* Lath. Albertus Magnus claims that the quail (q.v., *Coturnix communis* Bonn.) is the smallest of the partridges. He gives *quistula* as one of its vulgar names. Without doubt the partridge and the quail were well known as game birds to the author of the *De Arte Venandi*.

Passer. L. Sparrow.

Pavo. L. Peacock.

Peacock. The male bird of any species of the genus *Pavo* or peafowl, especially of the common species, *Pavo cristatus*, a native of India, now everywhere domesticated and considered to be the most imposing and magnificent of birds. Because of these characters and its strutting gait, it is regarded as a symbol of display and vainglory. It was well known to the Emperor. See also PHEASANT.

Peafowl. See PEACOCK.

Peewit. See SNIPE.

Pelicans. Kofani. Cofani. These birds belong to the genus *Pelecanus*—large, gregarious, fish-eating waterfowls, remarkable for an enormously distensible, membranous pouch, dependent from the lower mandible of their long, hooked bill and used for storing recently captured fish. Two species, *Pelecanus onocrotalus*,

the common or white pelican, and *P. crispus*, the crested pelican, are found in Southeastern Europe and adjacent regions, and are the original "pelicans." Other species inhabit the East and West Indies, Africa, India, the Malay Archipelago, and Australia.

Pliny was the first to furnish definite information about these curious avian forms, to which Aristotle gave their present name.

Pelicanus. L. Pelican.

Perdix. L. Partridge.

Peregrine. **Peregrin.** **Peregrine Falcon.** A courageous, graceful, and swift bird (*Falco peregrinus*) of almost global distribution. The adult plumage is dark bluish-ash on the back, nearly black on the head and cheeks, white beneath, barred with black below the throat. In Book VI and elsewhere in the *De Arte Venandi*, the Emperor fully describes this famous hawk. It was much used in falconry, and was quite familiar to ancient and medieval naturalists. The American *Falco peregrinus anatum*, or duck hawk, and *F. peregrinus pealsi*, Peale's falcon, are similar forms.

Phalacrocorax. **Corvus marinus.** See **CORMORANT.**

Pharoeseste. See **BRANT.**

Pheasant. This avian class may be described as including any of the numerous large, long-tailed, highly colored, gallinaceous game birds of *Phasianus* and allied genera. The common pheasant (*Phasianus colchicus*), the Chinese ring-necked (*P. torquatus*), *P. versicolor* of Japan, the peacock (*q.v.*), and many other species imported from the Far East were probably familiar to the Emperor Frederick II as curiosities and as a banquet adjunct. Our common hen (*q.v.*) and cock are among the oldest of the domesticated pheasants. Albertus Magnus believed the fabled phoenix to have been the golden pheasant (*Phasianus pictus* Linn.); also other medieval naturalists thought the "satyr bird" to have been a pheasant. Aristotle and Pliny give considerable space to interesting accounts of the peacock, while Albertus Magnus describes the white (albinic) variety. In this connection Pliny tells us about the guinea fowl (*Numida melagris* Linn.) from Africa.

Philomela. L. Nightingale.

Phoenix. See **PHEASANT.**

Pica. L. Woodpecker.

Picacia. L. (?)

Pico. L. Woodpecker.

Pigeon. See **DOVE.**

Pinzones. L. Woodpecker (from *pinso*).

Pirol. See **ORIOLE.**

Platea. One of the ill-defined (predatory) sea birds mentioned by Albertus Magnus.

Plover. Shore game birds of the family *Charadriidae*. They differ from the sandpipers in having a short bill (hard at the tip, though more or less soft at the base) and in their usually stouter and more compact build. They are mostly gregarious and migratory, frequenting plains, grassy uplands (where they usually nest), and beaches. This bird was doubtless familiar—especially as a game species—to the Emperor.

Pluerius. L. Plover.

Pluviales. See under **ORIOLE.**

Pochard. See **RED GOOSE.**

Porphyrio. See **FLAMINGO.**

Praenus. The bird that hatches the cuckoo's eggs. See Book I, chapter xxiii-F, of the *De Arte*.

Psittacus. L. Parrot.

Ptarmigan. This is the vernacular name of a grouse (of the genus *Lagopus*) living in Northern regions. The species has completely feathered feet. In all except the British red grouse the winter plumage is chiefly or wholly white and the summer plumage largely grayish, brownish, or blackish, variously barred and vermiculated. It was a game bird undoubtedly known to Frederick II. See also **GROUSE.**

Quail. A migratory bird allied to the partridge (family *Perdidae*). The flesh of *Coturnix communis* or *dactylisonans* is much esteemed for the table. It is about seven inches long, with the upper parts brown, the back marked with buff, the throat black and white, the breast reddish buff, and the belly whitish.

Pliny and Aristotle regarded the royal quail (*Crex pratensis* Bechst.) as one of the true quails. Albertus Magnus agrees with this classification and quotes the latter's synonyms as

ortygometra and *kychramus*. See also PARTRIDGE and FRANCOLIN.

Queest. See RINGDOVE.

Quistula. See PARTRIDGE; FRANCOLIN.

Rail. Name given to any of the small (often very small) wading birds related structurally to the cranes. They have short, rounded wings, and usually very long toes which enable them to walk and run on the soft mud of swamps. They belong to the Rallinae, a subfamily of the Rallidae. Well-known European forms are the land rail or corn crake (*Grex crex*) and the water rail (*Rallus aquaticus*). The Emperor certainly knew these species. See CRANE and HERON.

Ralla tam campestris quam aquatica. L.
Land and water rails.

Rallus terrestrium quae dicuntur duces corniticum. L. Corn crake.

Raven. A widely distributed corvine bird (*Corvus corax*) of large size, with black, lustrous plumage and raucous voice, feeding chiefly on carrion.

The common raven is easily tamed but is mischievous and thieving, and has been popularly regarded as a bird of evil omen and mysterious character. In captivity it is intelligent and sometimes learns to articulate words. As Ernest Lewis pointed out, the Iceland gerfalcon sometimes utilized a raven's nest for her eyrie. The former was generally lined with eider, the original gerfalcon's eyrie being made of sticks only. There is no doubt these birds were well known to the Emperor, as they were to all medieval naturalists. They have many tales, authentic and other, to their credit. That they are omnivorous and kill other birds and small mammals for food is well understood. See also CROW.

Redfooted Falcon. *Tinnunculus ruffas*. A species known in medieval times. The name may also have been given to the orange-legged hobby (*Falco rufipes* vel *vespertinus*).

Red Goose. The European pochard (red-headed goose) was highly esteemed as a game bird from the earliest times, and was a species familiar to the Emperor.

Redhead. See RED GOOSE.

Regulus. See WREN.

Ringdove. The wood pigeon, cushat, ring pigeon, or queest (*Columba palumbus*). This species is a common European pigeon, larger than the stockdove or rock pigeon, having on each side of the neck a whitish patch; the wings are edged with white. There is also a dove (*Streptopelia risoria*) of Southeastern Europe and much of Asia allied to the common turtledove; it is of a buffy color with a black collar. These birds were all familiar to medieval naturalists.

Saker Falcon. Saker. This bird of prey was well known in medieval times. It has a number of synonyms, among them *Falco sacer*, *britannicus*, *aelius*, and *aeriphilus*. It was commonly distributed throughout Europe; besides avian prey it chased small mammals, sometimes the roe. The saker has always had the reputation of being a fierce, swift, courageous, and very useful hunter. The Emperor was well acquainted with the species and has described it and its hunting habits and uses in falconry at considerable length in Book V of the *De Arte Venandi*.

Albertus Magnus gives what we may regard as specific rank to several races that are really only age and color variants of one species, among them *Falco lapidarius*, *F. arborealis*, *F. gibbosus*, and *F. montanarius*. His "blue-footed falcon" is the young of *F. peregrinus*. He does, however, recognize a true and important species, also known to Frederick II, viz., the large, dark-colored Eleonora falcon (*F. eleonorae* Brehm), whose chief habitat is North Africa and the Greek islands. Albertus Magnus fully describes also the merlin (*F. aesalon* Linn.) and the lanners in his catalogue of medieval birds of prey. Both he and the Emperor make guarded references to crosses between these hawks, the latter definitely, however, in the case of his "blue-footed" falcons and the peregrines, although, as just mentioned, several supposed distinct species are at best only races.

The application of the term "falcon" in the literature of falconry is important; it has already been discussed at length in this translation.

Sandpiper. *Tringa*. Any of numerous, small limicoline birds, distinguished from the plovers chiefly by the bill, which in the former species is moderately long, often soft and sensitive at the tip, but not of the extreme length characteristic of the typical snipe. The legs and neck are moderately long, and the plumage is usually streaked with brown, gray, or blackish above and more or less extensively white below. They frequent chiefly sandy and muddy shores, breeding mostly in the arctic regions but migrating extensively into temperate latitudes. A species frequenting small inland streams and ponds is the common sandpiper of Europe (*Actitis hypoleuca*, syn. *Tringoides hypoleucus*). The sandpipers were certainly well known to Frederick II.

Satyr Bird. See PHEASANT.

Scamp. See SHELDRAKE.

Sea Crow. See CORMORANT.

Sea Eagle. See OSPREY.

Sea Raven. See CORMORANT.

Sheldrake. *Scamp.* *Tadorna tadorna*. A bird of the duck tribe, living on the sandy coasts of Europe, North Africa, and Asia, and remarkable for its bright and variegated coloring. Though somewhat resembling the goose, its nearest allies are the tree ducks. It nests in hollows. It is chiefly black and white, with the head and neck greenish, the lower breast chestnut, and the speculum green. The bill, with its frontal knob, is red. The ruddy sheldrake (*Casarca ferruginea*), of Southern Europe, Asia, and Northern Africa, is chiefly orange-brown with the quills of the wings and tail blackish and the colored area on the wing bronzy-green. The male has in summer a black collar. The species is abundant in India, where it is called "Brahmany duck." We have every reason to believe that this attractive duck was familiar to the author of the *De Arte Venandi*.

Simbolione. L. Merlin (?)

Sinecilione. L. Merlin (?)

Siskin. *Aberdevine*. A small songbird, in some respects closely allied to the goldfinch. This *Spinus spinus* is a sharp-billed, chiefly

greenish and yellowish finch, probably known to Frederick II.

Sisteroa. A large bird mentioned by Frederick II. It is still an unknown species, not satisfactorily identified by modern writers.

Skylark. See LARK.

Snakebird. See DARTER.

Snipe. Limicoline birds of the genus *Scolopax* (now *Gallinago*) characterized by having a long straight bill and by frequenting marshy places. Most species sport a plumage handsomely variegated with blackish-brown, buff, and chestnut above, and barred on the tail and sides. The common snipe (*Capella gallinago*) of Europe and parts of Asia and Africa is smaller than the great or double snipe (*C. media*) of the same regions. They are (and were in ancient and medieval times) much valued as game birds and formed familiar topics for ancient and medieval writers. One of the names for these avian forms in the *De Arte Venandi* is *livercini*. Aristotle's synonym was *ascolops* (hence *Scolopax*). Albertus Magnus includes the peewit and lapwing among these species.

Sparrow. A small, brownish-gray bird of the family Fringillidae, indigenous to Europe, where it is very common and is naturalized in various countries, especially the house sparrow, *Passer domesticus*.

The various European varieties were familiar to the Emperor, and more than one is depicted in his Vatican manuscript miniatures. It is among the most prolific of avian species. Albertus Magnus describes two classes of sparrows, one, a large, gray-headed species, of which *Passer domesticus* is the chief, and the other smaller, with red-brown coloration "inhabiting yellow trees," probably *Passer montanus* Linn.

Sparrow Hawk. A species (*Accipiter nisus*) that preys on small birds; common in the British Isles and widely distributed in Northern Europe and Asia. It had a limited employment in falconry, a topic elsewhere discussed in this translation.

Species berniclarum et species iantabum. L.
Bernicle, or Barnacle.

Sperverius. L. European sparrow hawk.

Spinus spinus. See SISKIN.

Starling. A widely known bird of the passerine genus *Sturnus*. The European starling (*Sturnus vulgaris*) is dark brown (summer plumage greenish-black, with a metallic gloss) and spotted with yellowish-white. It is sociable, and builds about houses, old towers, etc. Pliny was the first to point out that it is in the habit of flying in flocks as a protection against hawks.

Starna. L. Redhen. Red-legged partridge.

Stone Curlew. One of the vernacular synonyms of the common thick-knee or any allied species of the genus *Burhinus* (syn. *Oedicnemus*). See also CURLEW.

Stone Plover. Any of various shore birds commonly known as thick-knees. Among these species are an Indian shore bird (*Esacus recurvirostris*); the black-bellied plover; the European ring plover; the dotterel; and the bar-tailed godwit—most of them familiar to medieval naturalists. See also CURLEW.

Stork. One of various large wading birds having a long, stout bill. They are allied to the ibises and herons but really belong to the family Ciconiidae. The best-known species is the common European white stork (*Ciconia alba*), with black flight feathers. The black stork (*Ciconia nigra*) has white underparts. Probably most of the Far Eastern storks (adjutant, etc.) were known to Frederick II. Albertus Magnus, Pliny, and Aristotle give full accounts of European storks and repeat tales (true and doubtful) about them. They are fond of all kinds of snakes, frogs, mice, fresh eggs, and other delicacies.

Struccio. L. Ostrich.

Sturnellus. L. Starling (from *Sturnus*).

Surene. L. Siskin (?).

Swallow. Any member of that numerous family, the Hirundinidae, small, long-winged, passerine birds noted for their graceful flight and regular migrations. They have a short bill with a wide gape and iridescent plumage, and are found all over the world. The popular name

covers the martins, the swifts, the bank swallows, the barn swallows, *et al.* It is needless to add that they were quite familiar to the author of the *De Arte Venandi*. Albertus Magnus gives considerable space to a description of the chimney swift (*Hirundo rustica* Linn.), to *H. urbica* Boie, and to *H. riparia* Boie, which were also known to Aristotle and Pliny. The former furnishes a good account of the black swift (*Cypselus apus*); and there is little doubt that the birds described by Albertus Magnus as *Doryachim driacha* and *D. melantorisus* were swifts.

Swans. These are large, web-footed, swimming birds of the family Anatidae, characterized by a long and gracefully curved neck and a majestic motion when swimming. *Cygnus olor* vel *gibbus* vel *mansuetus* has pure white plumage in the adult, black legs and feet, and a red bill surmounted by a black knob, commonly known as the domestic, mute, or tame swan. It was well known to and fully described by ancient and medieval writers. The fables (swan song, etc.) that cluster about it were often discussed by them. It was, also, quite familiar to the Emperor.

Swift. See SWALLOW.

Tadorna. See SHELDRAKE.

Teal. This is the common name of a small, freshwater species, including *Querquedula*, *Anas*, and other varieties of the genus, the smallest of the ducks, widely distributed in Europe and Asia, and well known to medieval naturalists.

Tern. See also GULL. Gull-like species of *Sterna* and allied genera. Unlike the true Laridae, they are comparatively small, slender and graceful, and have straight, unhooked mandibles and a long, forked tail. Moreover, they feed on live fish (which they capture by plunging after them into the water) and not on dead or dying ones as do the gulls. They were as a rule known to medieval writers on natural history.

Thick-knee. Any of certain large, long-legged, three-toed plovers of *Burhinus* (syn. *Oedicnemus*) and allied genera, found in the Eastern Hemisphere, somewhat allied to the bustards; also a stone curlew. They have a rather large

head and large eyes, and are most active at night, frequenting open heaths as well as stony shores. *Burhinus oedicnemus* is the European species, familiar to medieval ornithologists. See also CURLEW.

Thrush. Mavis. Any one of numerous small or medium-sized passerine birds belonging to the widely distributed family Turdidae. Typical thrushes are as a rule dull and uniformly colored, but many have spotted underparts. They feed largely on worms, insect larvae, berries, and fruits. Their primaries are ten (the first spurious), the tarsi are booted, and the young have the entire plumage spotted. Among them are some of our best songsters. European species include the song thrush, the missel thrush, the redwing, the fieldfare, and the blackbird. However, the best-known member of the family is the nightingale, famed in ancient and modern song (*Luscinia philomela* Bp.) and, like the majority of the other thrushes, well known to Frederick II.

Tree Falcon. *Falco subbuteo*. See HOBBY.

Tregopolis. A pheasant-like species with feathery tufts (crests); probably the satyr bird, *Ceatornis satyra* (Killermann).

Tringa. See SANDPIPER.

Turdus. L. Thrush.

Turtledove. *Turtur auritus*. See DOVE.

Turtur. See DOVE.

Turturus. L. Turtledove.

Ubleti. L. Hobby.

Uhan. Long-eared owl.

Uhu. See BUBO MAXIMUS.

Upupa. L. Hoopoe.

Upupa epops. See HOOPOE.

Vanellus. L. Lapwing.

Victicocius.¹ L.

Vulpanser. A vulgar synonym of the sheldrake (*Anas tadorna*) (q.v.).

Vultur. L. Vulture.

Vulture. One of many large birds of prey belonging to the order Raptores that feed almost entirely upon carrion and have head and neck

altogether or almost featherless. They are allied to the hawks, eagles, and falcons, but have weaker claws than they. Albertus Magnus recognized in particular the lammergeier (*Gypaetus barbatus* Cuv.) and a gray vulture (probably *Gyps fulvus* Gm.). See LAMMERGEIER.

Water Hen. See COOT.

Water Rail. A bird, *Rallus aquaticus*, having a general resemblance to the land rail (see RAIL), both natives of temperate portions of the Eastern Hemisphere. See also COOT.

Whitethroat. See GARDEN WARBLER.

Wood Lark. See LARK.

Woodpecker. Any one of more than three hundred species of scansorial birds of the family Picidae found all over the world except in Australia and Madagascar. They have two toes in front and two behind. The tail feathers are stiff and spiny, to aid in climbing or resting on tree trunks. The tongue is usually extensile, and the bill very hard and chisel-like, enabling them to drill the bark and wood of trees for their insect food or to excavate cavities in which they lay their glossy white eggs. A few species feed partly on the sap of trees and others seek insects on the ground. They are among the most beneficial of birds. Their plumage is generally parti-colored, black, white, brown, green, yellow, orange, and red in varying proportions and usually strongly contrasted. The three-toed woodpecker has the innermost or first toe reduced or absent. These birds are black and white with yellow crowns in the male; and they frequent the northern, evergreen forests of the Old and New Worlds (Webster). Most varieties were well known in medieval times. Albertus Magnus includes in his roster of the woodpeckers a "*picus linguosus*," undoubtedly the black variety (*P. martius* Linn.), while Aristotle, long before him, carefully described *P. viridis* Linn.

Occasionally the woodpeckers were confounded with the bee-eaters. For example, Albertus Magnus described *Merops apiaster* Linn. under the woodpeckers, while Aristotle mentions at least one species of the latter (*Jynx torquilla*) apparently unknown to the former writer.

¹ *alie habent (rostrum) longum et rectum ut victicocij, picacie et hujusmodi (De Arte Venandi, Book I, chapter xxvi).*

Wren. Any songster of the Trogloditidae. The common European wren (*Nannus troglodites*) is a very small, dark-brown, barred, and mottled species, with a short, erect tail. Although of small size this pretty little bird is alert and courageous, attacking larger birds in defense of his rights. As *crochilus* and *regulus* he was probably known to the Emperor Frederick II, having, under these synonyms, been described by Albertus Magnus.

Yellowhammer. See GOLDFINCH.

Yrundo (hirundo). L. Swallow.

Zeleucides. A species said by Pliny to follow the grasshopper and the locust and to be dependent upon them as food. Killermann identifies it as *Asturina polizona*, the locust hawk, whose habitat was the African plains. These birds were in all likelihood also known to the author of the *De Arte Venandi*.



Annotated Bibliography of Ancient,
Medieval, and Modern
Falconry

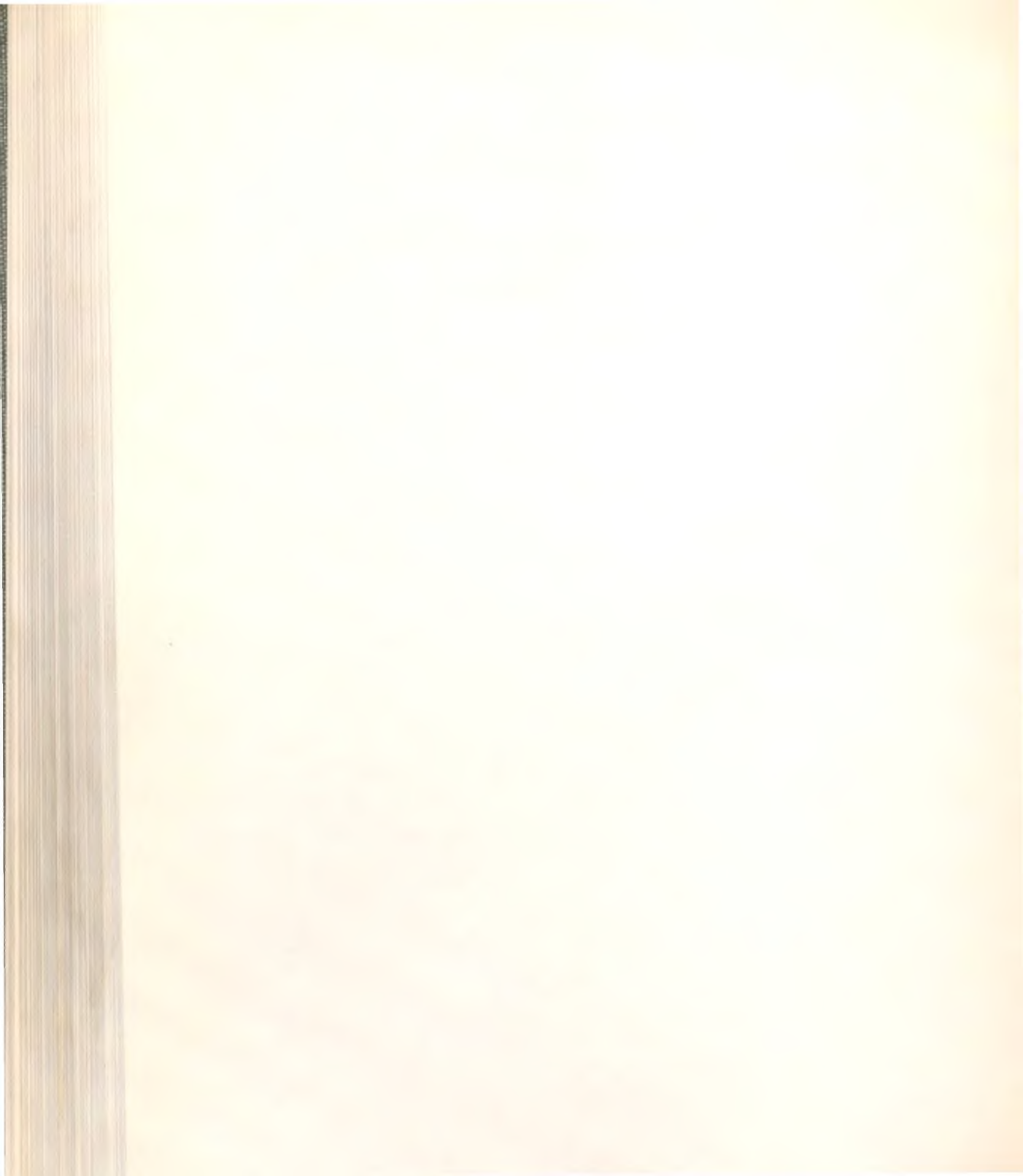

AN ANNOTATED BIBLIOGRAPHY OF ANCIENT, MEDIEVAL, AND MODERN FALCONRY

 HE TRANSLATORS are well aware of the futility of attempting to publish a complete or even a nearly complete collection of titles answering to the heading given above, even if that purpose were a desirable one. However, Harting (*q.v.*), apparently having in mind such a project in his excellent *Bibliotheca Accipitraria*, gathered to the end of 1891 a catalogue of 378 works on falconry in nineteen languages.

Now after the succeeding fifty years, such has been the growth of interest in the times and activities of Frederick II, and following the discovery of literary items unknown to the erudite Secretary of the Linnean Society, that it would be easy to increase Harting's list to more than thrice that number, written in at least twenty-four tongues. When one examines, for example, Thiébaud's *Bibliographie des Ouvrages Français* (1937) and Schwerdt's monumental volumes, this fact is at once apparent; more than three hundred additional titles dealing with falconry, within the limits apparently set by Harting, are there noted that do not, for good reasons, appear in the latter's carefully prepared list.

Again, the translators do not always see eye to eye with Harting in his estimate of the reference value of a work; nor do they always agree with his verdict either to include them in his *Bibliotheca* or to exclude them therefrom. On the whole, they have attempted to select for annotation from the numerous

printed volumes, periodicals, manuscripts, encyclopedias, voyages, atlases, biographies, histories, offprints, reprints, and inedited essays on the subject such titles as in their judgment will most effectively assist not only the average reader but the advanced research scholar to obtain the information of greatest value. Further, to the student who wishes to plumb the depths of Frederickian literature we recommend a close study of Haskins' works noted in this bibliography.

The chief source of the material thus selected has been the libraries of McGill University. Many of the titles quoted in the present bibliography will be found in the senior translator's *An Introduction to the Literature of Vertebrate Zoology* (4to, pp. xvi + 643, Oxford University Press, 1931). The special libraries of McGill University possess most of these works, which may be consulted at any time by the research scholar. In this bibliography such items are designated as follows: .B., Blacker Library of Zoology, and .O., Osler Library of the History of Medicine and Science. This latter collection was annotated by Sir William Osler in the treatise *Bibliotheca Osleriana* (4to, pp. xxxvi + 785, Oxford, 1929). .W. refers to the Wood Library of Ornithology, and .G. to the Gest Library of Chinese Literature, one of the most comprehensive private collections ever gathered, no longer on deposit at McGill University, but now at Princeton, New Jersey. Several years ago its librarian, Dr.

Nancy Lee Swann, kindly selected for the information of the senior translator such Chinese titles as related especially to natural history. From these works, the titles on falcons and hawks have been abstracted and noted in this bibliography.

Although the McGill Libraries have by far the largest collection of original drawings of animal life, including bird portraits, to be found in any American university library, and probably also of periodicals and serials on ornithology, we have not here followed Harting's *Bibliotheca* in cataloguing that material, which, in our opinion, is of restricted value for this translation. Nearly every comprehensive work on birds describes the raptors, and to quote these would pad this monograph beyond capacity.

For several years Mr. Wladimir Ivanow, formerly curator of Persian manuscripts in the Imperial Library at St. Petersburg, has been collecting medical and natural history material in India and Persia for the senior translator. To him we are indebted for most of the works on falconry in Arabic, Bengali, Persian, and Hindi described in the present list.

Unless otherwise specified, Harting references (under .H.) are to the pages of that writer's *Bibliotheca Accipitraria*. References to the Redpath Library are keyed .R.

We are much indebted, also, to Mr. Alfred B. Maclay of New York for access to his remarkable collection of works on falconry, several of them unique and many extremely rare.

ABBOTSFORD CLUB. *Edinburgh*. Letters and state papers during the reign of James VI, chiefly from the manuscript collections of Sir James Balfour of Denmyln; ed. by J. Maidment. Edin., 1838. 4to. pp. 16+20+416. .R.

ABU 'ALI HUSAIN IBN SINA (AVICENNA) (980–1037). A seventeenth-century original Arabic manuscript of the *Kanun*. 5 books. .O.

———. *De Animalibus*. Translated by MICHAEL SCOT (J. and G. Gregariis, Venice, Hain-Copinger 2220). n.d., but not after 1500. .W.

———. *Danish-nāma-i-Alā'i* (*Natural History and Natural Philosophy*). Persian copy of an eleventh-century original 4to. pp. 72, lithographed. Hyderabad, 1891. .W.

All the foregoing (and many more Oriental titles in the McGill Libraries) contain accounts of bird life of interest to students of medieval ornithology.

The famous author, best known as Avicenna, was born in Bokhara. Probably the translations by Michael Scot from the Arabic (on natural history) were made by command of Frederick II.

ABUL FAZL 'ALLAMI. *The Government of Akbar* (*Ain i Akbari*) (A.D. 1590). Translated from the original Persian by H. BLOCHMANN. 8vo. Calcutta, 1873. .W.

This interesting monograph, printed for the Asiatic Society of Bengal, furnishes (pp. 293–96) an account

of falconry in Persia. Harting (p. 198) recognizes among the vernacular names of the hunting-birds: peregrine (*Shāhīn* and *Bahri*); gerfalcon (*Shungar*); saker (*Bālābān*, when captured in nets, and *Charkh*, when taken from the nest); merlin (*Turumtāi*); goshawk (*Tāigūn*, male and female); sparrow hawk (*Basha* and *Girgi*); and trained eagle (*Bargut*).

ADELARD OF BATH (12th century). *Quaestiones Naturales*. .W.

This short codex is preserved as MS. 2504 (ca. 1200) in the National Bibliothek, Vienna. The "queries" are on falconry and addressed to the author's nephew. The writer was attached to the court of Henry I, and his treatise, written in England, is probably the earliest manuscript produced in Western Europe. The greater portion of this little work forms part of a thirteenth-century script in Clare College, Cambridge, as MS. 15, fols. 185–87. The best accounts of this medieval writer are furnished by Haskins, *Romanic Review*, Vol. XIII (1922), No. 1; Lynn Thorndike, *A History of Magic and Experimental Science to 1327 A.D.* (New York, 1923), chapter 36; and Adelard's *De Cura Accipitrum* (q.v.) ed. by Swaen.

———. *De Cura Accipitrum*; a mediaeval Latin treatise; ed. with introduction and notes by A. E. H. Swaen; pub. under the auspices of the Modern Literature section of the Allard Pierson Stichting at Amsterdam. Groningen, J. B. Wolter, 1937. 8vo. pp. 10+2+28. .W.

ADELUNG, JO. CHRIST. *Glossarium manuale ad scriptores mediae et infimae latinitatis, ex glossariis Car. Dufresne, D. Du Cange et Capentarii in compendium redactum*. 6 vols. 8vo. Halae, 1772-84. Osler Library has Carpenter's edition of 1840. See also DU CANGE. .O.

This dictionary of vernacular words not found in ordinary lexicons is for the average student of barbaric Latin, such as one finds in the *De Arte Venandi*, the best now available. For the advanced scholar the larger cyclopedias, herein mentioned, are also desirable.

AELIANUS, CLAUDIUS (3d century). 'Αἰλιανῶν τὰ ἐυρισκόμενα ἅπαντα. *Opera quae extant omnia, graece latineque e regione, edita . . . cura et opere Conradi Gesneri his accedit index alphabeticus*. Tiguri apud Gesneros fratres, 1556. folio. pp. 48+655+54. illus. .B.

One of the most important of the Greek naturalists undoubtedly studied and translated by order of the Emperor. This work is probably the *editio princeps* of the Latin translations of Aelian's works (Wood Library). Many others of the numerous treatises and translations on natural history by this well-known Greek author are also in the McGill Library. The following are a few of them.

———. *De historia animalium libri XVII*
Item Demetrii De cura accipitrum. Lugduni, Apud G. Rovillium, 1562. 12mo. pp. 16+668+38. .B.

This edition is largely devoted to birds and in some degree to falconry (Lib. II, cap. 42). It is a translation by Petrus Gillius from the original Greek; a very rare item, not mentioned by Brunet; also in the Blacker Library.

———. *De historia animalium libri XVII*
Lugduni, Apud G. Rovillium, 1565. 12mo. pp. 16+668+38. .W.

Almost identical with the 1562 edition.

———. *De historia animalium libri XVII*
Petro Gillio & Conrado Gesnero interpretibus. [Gr. and Lat.] Colonia Allobrogum, Apud P. Albertum, 1616. 32mo. pp. 8+1018+94. .B.

———. 'Αἰλιανῶν περὶ ξύων ιδιοτήτος βιβλία ΙΖ'. *De natura animalium libri XVII; [Gr. and Lat.] cum animadversionibus Conradi Gesneri et D. W. Trilleri: curante Abrahamo Gronovio qui et suas adnotationes adjecit*. Londoni, G. Bowyer, 1744. 2 vols. 4to. .B.

One of the best editions.

———. *Histoires diverses d'Elie, tr. du Grec avec des remarques* [par J. B. Dacier]. Paris, Moutard, 1772. 8vo. pp. 12+520. .W.

The birds and falconry are not as fully discussed as in most of the other editions here catalogued.

———. *Aeliani de natura animalium libri XVII interpretum* J. G. Schneider. 2 vols. 8vo. Lipsiae, 1784.

This translation, by a well-known falconer and author, with his annotations, is probably the most useful of all the many editions of Aelian, including those published in the eighteenth and nineteenth centuries. It may be added to the foregoing that, in his *De Natura Animalium*, Aelian (Lib. IV, cap. 26) informs us that falconry was practiced in Central Asia as early as 400 B.C.

ALAGONA, ARTHELOUCHE D', SEIGNEUR DE MARAVECQUES (16th century). *La Fauconnerie*. Poitiers, 1567. 4to. pp. 32. .W.

An important work, always printed with the treatise of Jean de Franchières (*q.v.*). Harting tells us that it passed through ten editions before 1629.

———. (*La*) *fauconnerie*. (See FRANCHIÈRES, JEAN DE. *La fauconnerie*. 1621. fols. 86-101.) .W.

———. *Ibid.* 1628. .W.

ALBERICUS TRIUM FONTIUM. *Monumenta, Scriptores*, XXIII, 943.

Includes stories about Frederick II and his court. Quoted by Haskins. Not seen.

ALBERTUS MAGNUS, Bishop of Ratisbon (1193-1280). *De falconibus asturibus et accipitribus in opere De animalibus*. Folio. Roma, 1478. .O.

The first edition of a famous work compiled by Bishop Albert de Bollstädt, surnamed the Great. For a full account of this writer's ornithology the reader is referred to *Albertus Magnus als Zoologe*, by Heinrich Balss, 1928, and to Killermann's *Die Vogelkunde des Albertus Magnus*, Regensburg, 1910. See also this translation.

———. *De falconibus asturibus, accipitribus; ex libro eius XXIII. De animalibus* (in Frederick II, *Emperor of Germany*, 1194-1250. *Reliqua librorum Friderici II, imperatoris, De arte venandi cum avibus* 1596. pp. 359-414). .B.

ALBERTUS MAGNUS. *Traité de fauconnerie* (in Dancus, *Supposititious King of India. Le livre du roi Dancus*. 1883. pp. 31-94). .W.

———. *De animalibus*. Folio. Mantua, 1479. (Paul of Butzbach.) Hain-Copinger 546.

This edition is fully reviewed by Stadler (*Beiträge z. Gesch. d. Philos. d. Mittelalters*, Bd. 15-16, Münster, 1916-1921). .O.

———. *Summa naturalium (Philosophia naturalis)*. Small 4to. B. Farfengus, Brescia, 1490. Hain-Copinger 504. .O. 7406

———. *Das Buch der Versammlung . . . und von etlichen Thieren*. Strasbourg, 1508.

According to Brunet, this is the first translation of the *De animalibus* and, like all the other titles, includes a discussion of medieval bird lore and, incidentally, falconry. Another German translation was made by Walther Kyff and published in 1545 at Frankfurt am Main. It is an octavo of 172 folios, with 215 colored illustrations, and exceptionally rare. Here one may repeat the words of our Introduction not only about the scientific standing of Albertus Magnus as a falconer and ornithologist but also about the propriety of interpolating his chapter on birds of prey in the early manuscripts of the *De Arte Venandi*, and in copies of it by Velsler, Schneider, and others. He was a practical observer neither of falconry nor of birds, and his contributions on these subjects are merely crude compilations.

ALDOBRANDINO DA SIENA. *Practica oculorum*. MS. 1497 (*Sec. 15*). Biblioteca Angelica, Rome.

It is now established that Aldobrandino wrote his *Regime du Corps* for and at the command of Frederick II. There are three manuscript copies known—Oxford, Bodleian, 179; Paris, Bibliothèque Nationale, 1288; and Vatican Library, Rome, 1334, all fifteenth-century. The author is variously styled Halebrandio, Helebrandio, and Alebrano (di Siene or Firenze). (A. Klebs.)

ALDROVANDI, ULYSSE (1522-1605). *Ornithologiae, hoc est de avibus historiae Libri XII*. Folio. Bononiae, 1599-1664.

This work, which forms a portion of Aldrovandi's *Opera Omnia*, is the earliest of fifteen treatises (the last an Italian folio, Imola, 1908) shelved in the Osler, Wood, and Blacker Libraries of McGill University, of which three are selected for annotation. The author, a celebrated naturalist of Bologna, although blind until a few years before his death, devoted his whole life to lecturing, collecting specimens, and writ-

ing numerous treatises on biological subjects. In most of the Latin editions, Liber I devotes sixteen chapters to birds of prey in general. The taming and the training of hawks for falconry purposes are sketched in Liber IV and Liber VI. Although the avian parts of the Aldrovandi monographs have quoted much from the *De Arte Venandi cum Avibus*, from Demetrius, Carcano, and Albertus Magnus, they are interlarded with valuable observations original with the industrious Bolognese. The two additional editions commented upon (no useful purpose can be served by giving all the McGill items) are listed below.

———. *Ornithologiae, hoc est de avibus historiae Libri XII-XVIII*. Frankofurti, 1610. 2 vols. in 1. illus. folio. .W.

———. *Ornithologiae, hoc est de avibus historiae Libri XII-XX*. Bonn, 1645-46. 3 vols. illus. folio. .W.

This forms Vols. 8-10 of the *Opera Omnia* in 13 volumes (1638-68) shelved in the Blacker Library.

ALEXIS MICHAELOVITCH, TSAR. *Tsar'ya Alekseyéya Michailovicha Knigha glagolemsya uryádnik: nóvoe ulozhénie na ustroenie china sokolnichova púti*. 1668.

The English translation of this transliterated Russian title is: "By the Tsar Alexis Michaelovitch The Book Called the Law: New Rules and Regulations for the Practice of Falconry. 1668." Harting (pp. 184-85) furnishes an interesting commentary. The Tsar maintained an extensive hawking stud, employed a large number of falconers, and was himself an enthusiastic follower of the noble sport. The special code above presented dealt with falconry in all its relations, legal, historical, and practical. The rank, duties, and dress of the various falconers were meticulously set forth. Even the trappings of favorite birds are minutely described, and the names of 92 of them are given, while the sources, taming, and training of the hunting-birds are duly set forth. For various reasons falconry under subsequent Tsars declined in Russia, although in 1884 a Russian falconry club was formed in St. Petersburg.

ALLMAYER, ALESSANDRO. ed. *Un poemetto inedito del secolo XV sulla caccia cogli uccelli di rapina esistente nella pubblica Biblioteca comunale di Siena*. [Siena, Tipografia editrice, S. Bernardino, 1892.] 4to. pp. 10+31. .W.

On cover: Per le nozze Bartalini Mucci. "Probably privately printed by the officials of the Tipografia di S. Bernardino, to celebrate the wedding of these two well-known Sieneze citizens, and distributed among their friends, and one may reasonably conclude

- that at least the bridegroom, Carlo Bartalini, was much interested in falconry."—CASEY A. WOOD.
- ALLSHORN, LIONEL. *Stupor Mundi*. Lond., M. Secker, 1912. 8vo. pp. 318. front. 8 pls. .W.
- An important and extremely well-written study of Frederick II, in part popular but reliable and of considerable value in this translation.
- ALVESFORD CATALOGUE. (Privately printed.) Hunting, hawking, shooting . . . books on, manuscript prints and drawings. 102 illus. 3 vols. Old Alvesford House, Hants, Jan. 1929. Not seen.
- AMARI. *Storia dei Musulmanii di Sicilia*. Quoted by Haskins.
- Deals with the Saracen retainers in Frederick's court. Not seen.
- ANCONA, PAOLO D' (1878—). *La Miniature Italienne du X^e au XVI^e siècle*; tr. de P. Poirier. Paris, G. van Oest, 1925. folio. pp. 4+2+128+4. pls. .W.
- Pages 18 and 19 are devoted to the illustrations in the *De Arte Venandi*.
- ANGELI DA BARGA, PIETRO (1517–1596). *De aucupio Liber Primus*. 4to. Florentia, 1566. .W.
- This is a book of verses by a poet *detto comunemente "il Bargeo,"* who intended to cover four books but who did not publish the final three. It treats chiefly the art of catching falcons, hawks, and other birds by means of birdlime. See THOU, JACQUES AUGUSTE DE. (*Il falconiere*
- ANONYMOUS. *Bas Nāmā (Book of the Hawk)*. 1680. .W.
- Of the many Persian works (anonymous and fully entitled) known to collectors is one in the British Museum (catalogued by Rieu, II, 486) dedicated, as were many such, to the Mogul Emperor Aurangzeb. It is a metrical treatise, divided into 43 *bābs* or chapters, fully describing the catching, taming, training, and care, in both health and illness, of hunting-birds, as carried on in Persia.
- . *Bas-Nāmā*. Treatise on the diseases of falcons. 12mo. Verbal pagination. pp. 48. Hyderabad. Transcribed ca. 1760. .W.
- . *Bas Nāmā*. ca. 1780. .W.
- A concise Persian treatise on falconry secured by W. Ivanow for the Wood Library. Author and copyist, date of composition, and title of the larger work of which this is an abbreviation are all unknown. The care, training, diseases, and treatment of hunting-birds receive special attention; altogether an important addition to the literature of Oriental hawking.
- . *Bas Nāmā*. Fragment of a Persian treatise on falconry—probably a commentary on a still larger work of unknown title. 18 *bābs*. pp. 22. 1900. .W.
- . *Bas Nāmā*. A Persian manuscript tract on falconry. 8vo. 11 fols. ca. 1905. .W.
- Fragmentary but important. No further details available. Probably the original is lost and only this modern excerpt remains. Notes by W. Ivanow.
- . *Baz-Nāmā*. 17.5 x 9 cm. 11 fols., 13 lines, colored. European paper. Calcutta, ca. 1905. .W.
- This transcript is an Indian commentary (*nastalikh-shikasta*) on a larger and much earlier work. (Ivanow.)
- . *Chin hsiu wan hua ku*. 24.2 x 16.1. ca. 1500. .G.
- This classified cyclopedia treats zoological subjects, including birds in their various relations, and was certainly published originally sometime during the Ming Dynasty, i.e. 1368–1644.
- . *Das erste Buch vahet also an und leret paissen (Beyssen, beizen, oder beitzen) und auch den Habich erkenne*. ca. 1472. small 4to. Augsburg. (photostat only) .W.
- Harting (p. 45) describes this incunable as black letter, 46 leaves, without pagination and signatures; 22 lines to a page; no date, no author. It is the earliest printed book on falconry in any language. He also says that only one copy is known, formerly in the library of the Abbé de Bearzi. However, as the Wood Library possesses a photostat copy made for it by the Prussian Staatsbibliothek in Berlin, there are at least two in existence, unless it happens that the Abbé's example is the one now in the German capital.
- . *Ehon Taka Kagami (Mirror of Falconry)*. 8vo. 5 parts, well illustrated. ? 1850.
- This treatise is probably the best work in Japanese available for the student. Early falconry in Japan is generally described in Chinese works on the subject, and although there are quite a few volumes in which hunting by means of birds in Japan is separately discussed, the modern disappearance of the sport in that country will account for its sparse literature.
- . *La Fauconnerie (Chasse au vol)*. *Quelques détails sur les faucons et l'art de les dresser*

à la chasse. Printed and published by W. P. Van Stockum. La Haye, 1840. pp. 20.

Not seen. Valuable because of a list of members of a Holland falconry society. 1839. Rare. See Thiébaud, p. 386.

ANONYMOUS. *Hieracosophion, sive de re accipitraria*. See THUANUS.

———. *Instruction pour élever, nourrir, dresser, instruire et panser toutes sortes de petits oyseaux de volière . . . avec un petit traité pour les maladies des chiens*. Paris, 1674. 24mo. pp. 12+84. vignette. 4 tailpieces; table of contents.

.W.

This curious little treatise, of no special importance, must be very rare. It was published by Chas. de Sercy, who printed several works on falconry.

———. *Kitabu'l-haywan*. A Persian zoological dictionary in manuscript. n.p. n.d. ca. 1580.

.W.

Hunting-birds are briefly described. Ivanow believes the treatise to be unique.

———. *Les plaisirs innocens et amoureux de la campagne contenant le traité des mouches à miel ... avec la méthode d'élever, nourrir & guérir toutes sortes d'oyseaux de ramage et du traité de chasses ...* Grenoble, A. Giroud, 1692. 16mo. pp. 8+220.

.W.

Fauconnerie is treated on pp. 212-20. A rare and curious little book of interest chiefly to collectors of works on sport. Another edition, 12mo, also rare, was published at Amsterdam in 1699.

———. *Saydiyya*. A Persian manuscript treating hunting (inclusive of falconry) from the religious (Shihite) viewpoint. Incidentally it furnishes a list of birds in Arabic, Persian, and Hindi. small 4to. 21 folios. Notes by Ivanow.

.W.

———. *Sparhawks or Goshawks. A perfect book for keeping of*. Printed from the original MS. 1575. London, 1886.

Maclay Collection. Very rare.

———. *Turkish Codex. Das ist Falkenbuch*.

See HAMMER-PURGSTALL, JOSEPH. *Falknerklee*.

.W.

ARCHIBERNARDUS. *Liber falconum*. Latin poem

of 324 hexameter lines. In the Vatican Library as MS. Ross. VII. 58. 13th century.

The subject of this unknown author concerns the species, care, food, and diseases of falcons. For further particulars, consult C. H. Haskins, "Some Early Treatises on Falconry," in *Romanic Review*, XIII (1922), 25.

ARCOS, S. *Fauconnerie*. (Paris) Exposition de 1889.

An illustrated and useful account published in 1890.

ARCUSSIA, CHARLES D', VICOMTE D'ESPARRON (ca. 1545-1617). *La fauconnerie ... divisée en trois livres; avec une brève instruction pour traicter les Autours*. Aix, 1598. 8vo.

Harting regards this as the *editio princeps* and mentions a second edition, *divisée en quatre parties*, Paris (Jean Houzé), augmented by De Gommers, *De l'autourserie*, 1605.

———. *La fauconnerie ... divisée en cinq parties; reveue, corr. et augmentée en cette dernière éd. de plusieurs advis, instructions et receptes nécessaires à ce sujet. Et de la cinquième partie, à laquelle sont adioustez plusieurs portraits des instruments pour servir à la cure des oyseaux*. 5^e éd. Paris, chez Jean Houzé, 1607. 12mo. pp. 8+528+14. illus. pls.

.W.

As in most instances, the five engraved plates are missing but these (*Instruments pour servir à la cure des oyseaux*) have been supplied in the Wood Library by a British Museum photostat. This item, like most of the d'Arcussia editions, is very rare. In addition to the printings indicated above, Harting mentions similar editions published in 1608, 1615, 1617, 1619, 1921, etc.

———. *La fauconnerie*. Divisée en dix parties. Avec les portraits au naturel de tous les oyseaux. Paris, chez Jean Houzé, 1627. 4to. pp. 7+406; table of contents, frontispiece, and the two (complete) folding plates.

.W.

There are also well-executed figures of ten hawks described in the text.

The present copy belonged at one time to the "Comtesse Amalia Belgica."

A rare edition of a well-known and valuable treatise. The copy in hand (from the Wood Library of Ornithology) has the original vellum binding and the whole housed in a protective box. There are two supplements, each with separate titles: "*La fauconnerie du roy, avec la conférence des fauconniers*,"

and "Discours de chasse 1627; Lettres de Philoierax à Philofalco," comprising the Second Section.

Souhart gives an extensive review of this work, one of the most important and useful in the entire literature of falconry. Harting lists still another printing of this edition that includes all the essentials that d'Arcussia has written and which is more correct than the preceding item. It was a quarto, published at Rouen, *chez François Vaultier*, in 1644. A German translation, says Harting (p. 49), is based on the 1607 edition. It appeared in 1617, a quarto from the press of Nicholas Hoffmann in Frankfurt am Main. The title is *Falconaria; das ist eigentlicher Bericht und Anleytung wie man mit Falcken und andern Weydtvögelen beitzen soll . . . in fünf Theil . . . von Carolo d'Arcussi*. It is illustrated by the same full-page engravings and hawking instruments as are the other editions. In 1883, a small octavo appeared in Paris, a reprint of the seventh part of the 1644 edition, entitled *La conférence des fauconniers*. Notes are appended by the editor, Ernest Tullien.

ARELLANO, JUAN MANUEL DE. *El cazador instruido, y arte de cazar con escopeta y perros, à pie y à caballo, que contiene todas las reglas conducentes al perfecto conocimiento de este exercicio*. 3d ed. Barcelona, Por la Viuda Piferrar, n.d. 32mo. pp. 8+134. .W.

Very little in this treatise about birds or falconry.

ARNDT, HELENE. *Studien z. inneren Regierungsgeschichte Manfreds*. 8vo. Heidelberg, 1911. .W.

A fair account of the private life and court of King Manfred, with numerous references to the Emperor Frederick II.

ARISTOTLE (384-322 B.C.). *Translacio tractatus primi libri quem composuit Aristoteles in cognitione naturarum animalium. ca. 1330*. .O.

A fragment of the translated *Historia animalium* from the Arabic and Latin, probably copied from the original made by Michael Scott at the instance of the Emperor Frederick II. This treasure is the earliest item in the Osler, Wood, and Black Libraries of McGill University. Of the remaining 28 natural history treatises there carded under Aristotle, a few short titles relating to birds and falconry by that erudite Greek writer (and seen by the translators) are listed here.

———. *Libri de animalibus*. Venice, 1476. Hain-Copinger, 1699. Proctor 4312. .O.

———. *Praepositiones ex omnibus Aristotelis libris philosophiae, etc.* folio. pp. 56+287. Venice, 1493. Ed. by Benedictus Soncinas. .O.

———. *Opera*; Graece, etc. folio. 5 vols. Ἀριστοτέλης περὶ ζῴων ἱστορία. Venice, 1495-98. .O.

The second volume of this rare and famous Greek edition contains the *History of Animals*.

———. *De natura animalium . . . interprete Th. Gaza*. Venice, 1498. .O.

———. *Paraphrases totius Philosophiae naturalis*. folio. 227 fols. Paris, 1510. .W.

———. *Habentur hoc volumine haec Theod. Gaza interprete. Aristotelis de natura animalium*. folio. Venice, 1513. .B.

A well-known Aldine print.

———. *De historia animalium*. Folio. Simon Colinaeus. Paris, 1533. .W.

———. *Histoire des animaux d'Aristote, avec la traduction française, par M. Camuss*. 2 vols. Paris, 1783. .W.

———. *Aristotelis de animalibus historiae lib. Graece et Latine . . . commentarium indices adjecit J. G. Schneider*. 4 vols. 8vo. Lipsiae, 1811.

———. *Zoologisch-kritische Bemerkungen zu Aristoteles Thiergeschichte*. 4to. pp. 2+27. Bonn, 1857.

———. *Aristotle's History of Animals*. In ten books. Trans. by R. Cresswell. 8vo. pp. 10+326. appendix, index. London, 1862. Bonn. .W.

An excellent and cheap edition.

———. *Thierkunde . . . Index von Aubert und Wimmer*. 2 vols. pp. 1052. 7 pls. Leipzig, 1868. .W.

An unusually good and complete review of the subject.

———. *The Works, translated into English by J. A. Smith and W. Ross*. 8vo. 11 vols. Oxford, 1908. .O.

Vol. V is devoted to birds and other animals.

———. *On Aristotle as a Biologist, with a Proemium on Herbert Spencer*. 8vo. Oxford, 1913. .B.

See THOMPSON, D'ARCY W.

ARTHELOUCHE D'ALAGONA, SEIGNEUR DE MARAVECQUES. See ALAGONA, ARTHELOUCHE D', SEIGNEUR DE MARAVECQUES. 16th century.

ASCARI, ARMANDO. *La caccia alle starnie*. Bologna, Cooperative Tipografica Azzoguidi, 1934. 8vo. pp. 189+4. illus. pl. .W.

Copy No. 124 of an edition of 500 copies.

AUBERT, HIPPOLYTE. *De l'Art de la Chasse des Oyseaux*. 8vo. Paris, 1911.

In an excellent account of the Geneva manuscript of Frederick II, the author furnishes a fine description of the miniatures in that copy of the *De Arte Venandi*. See also this author's *Bibliothèque de l'École des Chartes*, LXXII, pp. 307-9.

AVERY, M. *The Exultet Rolls of South Italy*. Princeton, 1936.

An extremely useful work issued by Princeton University, with a portrait in the Salerno MS. of the Emperor.

AVICENNA. See ABU 'ALI HUSAIN IBN SINA.

BACKHOUSE, JAMES (1825-1890). *A Handbook of European Birds*. 8vo. pp. 8+334. Anat. front. index. London, 1890. Falconidae, pp. 139-74. .W.

A useful work of reference, furnishing synonymy, vernacular names, and brief but accurate descriptions of all the European birds of prey mentioned by Frederick II and his contemporaries. One of many such treatises, most of which for lack of space have been disregarded in the present bibliography. See, e.g., SCOT, MICHAEL.

BAILLIE-GROHMAN, WM. A. AND F. See EDWARD OF NORWICH.

BALSS, HEINRICH (1886-). *Albertus Magnus als Zoologe*. 8vo. pp. 155. front. and 20 figs. in text; table of contents. München, 1928. .W.

A book of exceptional value to a student of the subject; and the treatise furnishes a remarkably complete bibliography.

BARNES, JULIANA (alias BERNES and BERNERS) (1388-1485). *Book containing the treatises of hawking, hunting, coat-armour, fishing, and blasing of arms. As printed at Westminster, by Wynkyn de Worde, the Year of the Incarnation of our Lord 1496*. (Small folio. London, 1810.) Reprinted by Harding and Wright, with an Introduction, pp. 104, by Joseph Haslewood. .B.

There have been many other editions (e.g. 1486, 1595, 1881, 1901), reprints, and *facsimilia* of this famous treatise, the first work on hunting in the English language, printed at St. Albans in 1486. Between that date and 1596 numerous variants and copies from the original appeared, several without the editor's name, undated, but now extremely rare. Only a few of these will be noted in addition to the foregoing, which is the best reprint of the first issue. It is a facsimile in color, has a well-written and instructive introduction, a useful glossary, glossarial indices, and many colored illustrations—all together an important contribution to medieval falconry. The volume is bound in tooled grained morocco, with decorated cover and gilt edges.

Of subsidiary interest is a unique manuscript of 46 pages, carefully transcribed in 1808, of a portion of the *Boke of Saint Albans* by the hand of (Sir) H. Ellis, Principal Librarian of the British Museum. This treasure, with tracings of the original woodcuts in black, is in the Blacker Library.

———. *The Boke of Saint Albans*, containing treatises on hawking, hunting, and cote armour: printed at Saint Albans by the schoolmaster-printer in 1486, reproduced in facsimile, with an introduction by William Blades. Lond., Elliot Stock, 1901. 4to. pp. 32+178. illus. .B.

BECHSTEIN, JOHANN M. (1757-1822). *Getreue Abbildungen naturhistorischer Gegenstände—des In- und Auslandes*. 80 Hefte. Atlas, with descriptive text. 1793-1809.

This is a very rare book (by a voluminous writer) and is probably the first of his many ornithological writings of which there are fifteen titles in the Wood and Blacker libraries. Several of these devote space to hunting-birds and falconry; but as a rule the author prefers *Stubenvögel* when he has original observations to offer, much of his matter on hawks and falcons being borrowed from other ornithologists.

BEEBE, C. WILLIAM (1877-). *The Bird: Its Form and Function*. 4to. 370 illus. pp. 12+496. index. Westminster, 1907. .W.

Valuable because of the pictures of avian forms, and helpful in comparing the same in the *De Arte Venandi*.

BEETON, SAMUEL ORCHART (1831-1877). *Book of Birds*, showing how to rear and manage them in sickness and in health. Lond., S. O. Beeton, n.d. 12mo. pp. 2+10+352. illus. pls. .W.

In the most unexpected places one occasionally finds an interesting and informative account of modern and medieval falconry; and this is the case with

- the present volume. A considerable section (pp. 161-218) is devoted intelligently to this subject, with appropriate illustrations.
- BEISSEL, S. *Vaticanische Miniaturen*. Freiburg, 1893. pp. 39; pls. xx.
Has a review of some illustrations in the Vatican Codex of the *De Arte Venandi*.
- BELANY, JAMES COCKBURN (fl. 1841-1878). *A Treatise upon Falconry, in Two Parts*. Berwick-upon-Tweed, The author, 1841. 8vo. pp. 12+278+6. pls. .W.
The first part lists the hawks employed in British sport; the second deals with the care, taming, training, and field work of the birds. A poor glossary and a text not always accurate.
Presentation copy from author to G. G. Bell. Armorial bookplate with falcon.
- . *Ibid.* Bound with "A full report of the evidence taken at the Thames police court, and the coroner's inquest, before Mr. Baker, and a respectable jury, at Stepney, on the 10th of June, 1844; on the alleged poisoning case," also, "The trial of J. C. Belany, for the murder of his wife, at the Central criminal court, on August the 21st and 22d, 1844"; with all the letters and opinions of the public press. Alnwick, G. Pike, 1844. 8vo. pp. 60+24.
- BELON (BELLONIUS), PIERRE (1517-1564). *L'histoire de la nature des oyseaux ... escrite en sept livres par Pierre Belon du Mans*. folio. pp. 28+381. illus. Paris, 1555. .W.
This well-known naturalist was the first to attempt the identification of avian names given by Aristotle and Pliny with those current in France at the end of the fifteenth and beginning of the sixteenth centuries. Pages 83-131 describe the diurnal birds of prey and furnish remarks on falconry. Subsequent writers (Bouchet and others) drew largely on Belon's treatises.
- BELVALETTE, ALFRED. *Traité d'autourserie*, illustré par ... Ernest Orange. Paris, Pairault, 1887. 12mo. pp. 137+2. illus. pls. .W.
Copy No. 241 of an edition of 400.
- . *Traité de fauconnerie et d'autourserie, suivie d'une étude sur la pêche au cormoran*. Evreux, C. Hérissey, 1903. 4to. pp. 10+269. illus. pls. .W.
This textbook was issued as *Traité d'autourserie* by Pairault in Paris in 1887 and is rare. Fairly good review of the subject; numerous, mostly full-page, illustrations; excellent French glossary.
- BERGANTINI, G. P. See THUANUS, *Il falconiere ...*
- BERGENGRUEN, WERNER. *Die drei Falken*. small 8vo. pp. 60. Dresden, 1937.
A novel, throwing some light on falconry during the Middle Ages in the old kingdom of Naples. It is of little scientific value.
- BERNERS, BERNES, or BARNES, JULIANA (prioress of Sopwell nunnery) (b. 1388). [*The Book of Saint Albans*.] *The book containing the treatises of hawking, hunting, coat-armour, fishing, and blasing of arms. As printed at Westminster by Wynken de Worde, 1496*. London, White and Cochrane, 1810. 4to. illus. pp. 2+104+172. (Literary researches into the history of the *Book of Saint Albans*.) Facsimile reprint. See BARNES, JULIANA.
- BERT, EDMUND. *An approved Treatise of Hawkes and Hawking*. Divided into three Bookes. The first teacheth, how to make a short-winged Hawke good, with good conditions. The second how to reclaim a Hawke from any ill condition. The third teacheth cures from all known griefes and diseases. London, 1619. Extensive table of contents. Cut of hawk and falconry furniture.
- . *Treatise of hawks and hawking*, for the first time reprinted from the original of 1619, with an introduction by J. E. Harting. Lond., 1891. 8vo. pp. 8+16+109. .W.
Facsimile. One of 100 copies printed by Ballantyne, Hanson & Coy, and published by Bernard Quaritch.
The original is now practically unobtainable. Even the meticulously prepared facsimile reprint (the volume now in hand), of which only 100 copies were struck, is very scarce. The latter was prepared with an excellent introduction, pp. i-vii, by J. E. Harting. The treatise is an unusually good example of careful observation and of practical application of what Bert himself saw and experienced.
- BERTAUX, E. *L'art dans l'Italie meridionale*. Paris, 1904.
This work gives an early description of the Emperor's portrait in the Exultet rolls.

BEUMELBERG, WERNER. *Friedrich II. von Hohenstaufen*. 8vo. pp. 93. n.d. (? 1934) Oldenburg i. O. and Berlin. .W.

A short account of the Emperor's life. The volume is of no particular scientific importance but has brief, infrequent references to his career as a naturalist.

BIECHLIN. *D'ses biechlin sagt*, etc. Augsburg, [1497].

One of the earliest and rarest books on hawking. Not seen.

BIEHRINGER. *Kaiser Frederick II.*

A popular study of the Emperor, quoted by Haskins. Not seen.

BLAINE, GILBERT. *Falconry*. Lond., P. Allan, 1936. 12mo. pp. 253. illus. pls. (Sportsman's Library, Vol. 15.) .W.

This manual is a very useful and well-printed guide to falconry, which the author has practiced for forty years. It is the best work on the subject offered the public in recent years. It contains, *inter alia*, a plea for the revival of a "noble sport."

BLANFORD, WILLIAM T. (1832-1905). *Observations on the zoology of eastern Persia during the journeys of the Persian Boundary Commission*. 2 vols. 8vo. pp. 8+516. 28 plates, mostly colored. index. London, 1876. .W.

Vol. II, containing the zoology report, was largely written by Major O. B. St. John. Here 248 species of birds are described, and in connection with birds of prey a very good account is given of falconry in Persia.

BLOME, RICHARD (d. 1705). *The Gentleman's Recreation, in Two Parts*. The first being an Encyclopedy of the arts and sciences, to wit, an abridgement thereof. The second part treats of . . . hawking, fowling, etc. . . . The whole illustrated with about an hundred ornamental and useful sculptures engraven on copper. folio. (London) 1686. .W.

The portion of this famous treatise (now very rare) that deals with falconry is found in Part Two; it is illustrated with five full-page copperplate engravings portraying various hawking scenes. The text provides the usual description of the noble sport in most of its relations, including a roster of avian diseases and their cure. Harting (p. 31) informs us that a second and corrected edition, also a folio, appeared in 1710.

BLOME, RICHARD, AND CUMING, E. W. D., ed. *Hawking or Faulconry*. London, Cresset Press, 1929. 4to. pp. 4+vii-xxxii+123+1. fold. front. 4 pls. 7 figs. in text. glossary. .W.

This exact reprint of the 1686 edition of Blome's *Faulconry*, part of the famous *Gentleman's Recreation*, is introduced by an interesting preface by the editor. Only 650 copies of this facsimile were printed, of which this one is numbered 516.

BOCCAMAZA, DOMENICO. *Trattato della Caccia, Libri VIII*. small 4to. 138 leaves. Roma, 1548.

The last three books of this excessively rare treatise are devoted to falconry. They are not of much importance.

BÖHMER-FICKER. *Regesta Imperii*. See HASKINS, footnote, p. 354.

This very important collection of memoranda re the activities of the Emperor Frederick, including a Register of falconry items during 1239-40, is frequently quoted by Haskins.

BOISSOUDAN, JACQUES ELIE MANCEAU, SEIGNEUR DE (fl. A.D. 1745). *Méthode pour dresser et faire voler les oyseaux pour le vol de la perdrix. Où il enseigne à bien tenir les oyseaux*, etc. 4to. Niort, 1864.

According to Harting (p. 100) the treatise, relating the experience of an erudite and practical falconer of seventeen years' standing, first appeared at the end of an edition of *La Vénèrie* by du Fouilloux (q.v.). In 1866 it was edited by Baron Pichon. In this textbook the goshawk is described as chiefly employed in hunting. Not seen.

———. *Le Fauconnier parfait ou méthode pour dresser et faire voler les oiseaux. Pour le vol de la perdrix, etc.* Paris, Pour la Société des bibliophiles, 1866. 8vo. pp. 12+72. .W.

This rare pamphlet (with two prefaces, one each by Baron J. Pichon and Baron du Noyer de Noirmont), written by a "gentleman of Poitou" in 1745, was not published until 1864. Cf. Harting, p. 100. It gives a good account in 48 brief chapters of falconry — especially with the goshawk — in western France.

BONAPARTE, (PRINCE) CHARLES LUCIEN (1803-1857). *A geographical and comparative list of the birds of Europe and North America*. 8vo. pp. 7+67. London, 1838. .W.

A work useful in tracing the identity of birds mentioned and portrayed in the *De Arte Venandi*. The book in hand is Canon Tristram's copy, presented to a friend by Wm. Yarrell.

BOND, RICHARD M. *Eating Habits of [American] Falcons*. Offprint from the *Condor*, March 1936, pp. 72-76. .W.

This writer is one of the chief exponents of falconry in the United States of America.

BORSA, MARIO. *La Caccia nel Milanese dalle origini ai giorni nostri*. Milano, U. Hoepli, 1924. folio. pp. 16+356. illus. .W.

A well-written monograph but one adding little to our knowledge of falconry *per se*.

BOSSI, LUIGI. *Trattato delle malattie degli uccelli e dei diversi metodi di curarle: Si aggiungono alcune ricerche utili e curiose di ornitologia*. 8vo. Milano, 1822. .W.

This rather important work on birds, avian diseases, their treatment, etc., must be excessively rare, as there is no copy in the British Museum and the treatise was not seen by Harting (p. 136).

BOUCHET, GUILLAUME. *Recueil de tous les oiseaux de proie, qui serve à la volerie et fauconnerie*. 4to. Poitiers, 1567. .W.

Like the treatise of Alagona (*q.v.*), this work compiled mostly from Belon, published in 1555 (*q.v.*), is printed as an appendix to the *Fauconnerie* of Jean de Franchières.

BRACK, WENCESLAUS. *Vocabularius rerum*. folio. 126 fols. Hain 3699. Osler 142. Augsburg, 1478. .O.

An important section of this, the first dated edition (doubtfully accredited to Brack) of a Latin-German lexicon, is devoted to a list and brief descriptions of animals, including birds employed in falconry. It is a very rare incunable.

BREHM, CHRISTIAN LUDWIG (1787-1864). *Der Vogelfang; eine gründliche Anweisung zur Einrichtung des Drossel und jeder andern Art des Vogelherdes, des Tränkherdes, des Lerchenstreichens, der Schneuse, der Schlingen, des Fanges mit dem Kauze, der Locke, der Heherhütte, des Wachtel- und des Rebhühnerfanges der verschiedenen Netz- und Raubvögelfallen u.s.w. nebst genauer Beschreibung aller zu fangenden Vögel*. Lpz., Baumgartner, 1836. 12mo. pp. 4+2+158. illus. .W.

BRODRICK, WILLIAM (1814-1888). *Falconer's Favourites*. Lond., Taylor & Francis, 1865. 6 pls. folio. .W.

Contains life-sized, colored lithographs of "all the British species of falcons at present used in falconry," with descriptive letterpress.

BROWNE (OR BROWN), SIR THOMAS (1605-1682). *Certain Miscellany Tracts* (C. Mearn). London, 1683. small 8vo. .O.

One of ten known copies of the first issue dated as above, not 1684, as Harting (p. 27) and others claim. See also S. Wilkin's *Life*, 1836. The Fifth Tract treats of "Hawks and Falconry, Ancient and Modern," and is chiefly taken up with the diseases and treatment of hunting-birds. Among the many titles in the Osler Library that holds by far the most complete collection in the world of Sir Thomas Brown's various writings is *Notes and Letters on the Natural History of Norfolk . . .* with Notes by Thos. Southwell, 8vo. pp. 26+102. front., table of contents, 4 append., index. London, 1902. Another copy is in the Wood Library. See LUBBOCK, RICHARD, in this list.

———. *Certain Miscellany Tracts*. No. 5 is of "Hawks and Falconry, Ancient and Modern," 1684. This is a second edition of the preceding item. .B.

BROWNE, J. WOOD. *Michael Scot*. Edinburgh, 1897.

An account of this astrologer and naturalist and of his relations with Frederick II.

BRÜLL, HEINZ. (*Das*) *Leben deutschen Greifvögel; die Umwelt der Raubvögel unter besonderer Berücksichtigung des Habichts Bussards und Wanderfalken*. Jena, G. Fischer, 1937. 8vo. pp. 6+2+144. illus. Bibliography, pp. 141-44. .W.

An excellent treatise on falcons and their habits.

BRUHN, LEO. *Hohenstaufenschlösser*. Königstein-im-Taunus and Leipzig, 1937. 4to. pp. 112. Numerous full-page pls. and figs. in text. .W.

A remarkably fine collection of views and plans furnishing the best yet published of pictures portraying, *inter alia*, Frederick II's castles and other buildings referred to in the *De Arte Venandi*; explanatory text, fine photographs, and brief notes of the Emperor's activities in general are also given. See also SHEARER, CRESSWELL.

BUC'HOZ, PIERRE-JOSEPH. *Les agréments des campagnards dans la chasse des oiseaux, et le plaisir des Grands Seigneurs dans les oiseaux de fauconnerie*. 12 mo. pp. 12+272. Chez l'auteur, Paris, 1784.

The first edition of nine books listed by Thiébaud, all published before 1787, on subjects connected with the chase, much of it devoted to falconry. All the editions are rare.

BUFFON, G. L. L. DE (1707-1788). *Histoire Naturelle* ... 4to. 44 vols. many illus. Paris, 1749-88. .B.

The first edition of nine books listed by Thiébaud, works of the famous French naturalist and his co-workers deals with the whole range of the various kingdoms. It is a series of monumental monographs of which ornithology forms an important part, including a good account of falcons and falconry.

The McGill Libraries have over 40 printings—several unique, many rare—of Buffon's works. One other than this will be entered here for reference because of its handy format. It happens to be quite scarce.

———. *Natural History* in four parts. 12mo. pp. 509. table of contents. 200 woodcuts. Halifax, 1856. Part II. Birds. Falcons and Falconry, pp. 164-67. .W.

Even in this short space medieval falconry is given attention and described as fully as in some other works that are accorded considerable space by Harting and others.

BULLIARD, PIERRE (1742-1793). *Avicéptologie Française: ou, Traité général de toute les ruses dont on peut se servir pour prendre les oiseaux*. 8vo. pp. 24+312. pl. Fifth edition, Paris, 1808. .W.

A treatise by an expert *oiseleur* on the best methods for trapping birds. Harting (p. 92) says the *editio princeps* was issued in 1778; second edition, 1783; others 1795, 1796, 1808, 1813, 1820, 1821, all from Paris; a German edition in 1840.

BURTON, SIR RICHARD FRANCIS (1821-1890). *Falconry in the Valley of the Indus*. Lond., J. van Voorst, 1852. 12 mo. pp. 12+4+107. pls.

A popular, interesting, but not always accurate description of East Indian falcons and falconry. The present volume is J. E. Harting's own copy. An owner, presumably Mr. Harting, has made the following note on the last page of the volume in hand: "Among the tribes of the N.W. Frontier of India, the Chitralis are expert hawk catchers. They construct a hut of stones with a small opening at the top near which they tether a live chicken as a lure. As soon as it has been seized by the hawk, the string (in the hands of the watcher concealed in the hut) is pulled and the hawk imagining that this is caused by the chicken struggling to escape, grasps it all the

tighter, until it is drawn into the hut and secured. The captive is tamed by "watching," as of old, that is, by keeping it awake for 3 or 4 days and nights, and without food, until it becomes more or less exhausted from weariness and hunger. It is then fed on the lure until quite tame. Colonel Durand in his volume '*The Making of a Frontier*,' states that he saw a hawk being flown at game *after only* one week's training." The same hand writes on another blank page the following verse, à propos of North Indian falconry:

"The deer bounds over the plain
The lagging dogs behind
Follow from afar!
But lo! the falcon o'er head
Hovers with hostile wings
And buffets him with blinding strokes."
(SOUTHEY, *Thalaba*, II)

See also, in this connection, Captain Meredith's chapter on trapping falcons (in this translation).

BYVRANCK, A. W. *Mededeelingen van het Nederlandsch Histor. Institut te Rome*. 1925. pl. 6, Vol. V, p. 34. .W.

This paper describes a codex in the Marciana Library in Venice that portrays falconry pictures exactly like some of those seen in the *De Arte Venandi cum Avibus*.

CAMPBELL, JAMES. *A treatise of modern falconry*; to which is prefixed, from authors not generally known, an introduction, shewing the practice of falconry in certain remote times and countries. Edin., Balfour & Smellie, 1773. 8vo. pp. 4+264. .W.

A good account of falconry in all ages. The introduction, pp. 29-118, describes methods of training and flying hawks and falcons. This work is scarce.

CARCANO, FRANCESCO SFORZINO DA (1500-1580). *Tre libri degli Uccelli da Rapina... ne' quali si contiene la vera cognitione dell'Arte de' Struccieri, & il modo di conoscere, ammaestrare, reggere, & medicare tutti gli Augelli Rapaci, Con un tratto de' Cani del medesimo*. small 8vo. Appresso Gabriel Gioliti de' Ferrari. Vinegia, 1547.

Fide Harting, this is the first edition of a most important treatise on falconry. For further notes, see under the Brescia, 1607, edition. Most of these numerous printings have been seen by the translators. Doubtless there are still others that they have not even mentioned.

———. *Dell'arte del Strucciero; con il modo di conoscere e medicare falconi, astori e sparaviere,*

et tutti gli uccelli di rapina. 12mo. pp. 82. illus.; table of contents; index. Milano, Per F. Ghisolfi, 1645. .W.

This particular printing is reviewed by Harting (p. 144), but it must be very rare, as it is not listed in the *British Museum Catalogue (Natural History)*.

———. *Tre libri degli uccelli da preda ne quali si contiene la vera cognitione dell'arte de' strucciere, & il modo di conoscere, ammaestrare, reggere, & medicare tutti gli augelli di rapina, con un trattato de' cani del medesimo, di nuovo ristampato.* Venetia, Gioliti, 1586. 24mo. pp. 24+249. illus. .W.

Treatise by a practical falconer acquainted with the literature of the subject; it was deservedly popular and ran through many editions. This tem was not seen by Harting and must be very rare.

———. *Tre libri degli uccelli da rapina, etc.* 9 fols. pp. 1-250. Woodcut on last leaf. small 8vo. In Vinegia, appresso Gabriel Gioliti de' Ferrari, A.D. 1568. .W.

This printing is almost identical with the *editio princeps*.

———. *I tre libri degli uccelli da rapina; con un trattato de' cani da caccia.* 16mo. pp. 16+218. Vignette. 12 figs. in text. 6 headpieces. table of contents. Vicenza, 1622. .W.

This present copy has the separately printed woodcut on the last leaf. It was published "per il Mettetti."

———. *Dell'arte del strucciero con il modo di conoscere, e medicare falconi, astori, e sparavieri, e tutti gli uccelli di rapina.* In Brescia, Per Pietro Maria Marchetti, 1607. 16mo. pp. 82+2. illus. .W.

Vignetted title and a few woodcuts in the text. Generally bound up with Federico Giorgi's *Libro* of same date (*q.v.*). The Wood Library of Ornithology has a separately bound copy. The first edition of this popular, well-written, small treatise was extensively copied by subsequent writers, Turberville and Raimondi, for example. It then passed through many editions with occasional title variants. This Brescia, 1607, edition was not seen by Harting. He notes the printing mentioned as well as a small octavo, Venetia, 1581, per i Gioliti; two editions of 1585 and 1586 (*vide supra*) not seen by him; another, a small octavo, Venetia, 1587; a small octavo, Vicenza, 1622, entitled *Tre Libri degli Uccelli da Rapina, etc.* Finally, a 1645 edition, 16mo, *Adornata con le sue figure*, issued at Milan per Filippo Ghisolfi. Carcano in his

preface claims his handbook to be mainly a record of forty years' experience as a falconer and that he had read also all the Italian and French works on falconry that were available.

Cassell's Illustrated History of England. Lond., n.d. 4to. Vol. I. illus. port. pls. maps, facsim. .R.

CAZWINI, ZAKARIYA. See KAZVINI, Z.

CERFON, C. *De la basse volerie et du dressage pratique de l'autour et de l'épervier.* 8vo. 36 engravings, 18 apart from the text. Vincennes, 1887.

Not seen. This treatise deals only with the sparrow hawk and the goshawk. An unusual series of illustrations are copied from an anonymous Japanese work (Harting, p. 212), *Ehon taka Kagami*, or *Mirror of Falconry*.

CERUTI, ANTONIO. *Trattato di Falconeria, testo di lingua inedito del secolo xiv. Tratto da un manuscritto della Biblioteca Ambrosiana a cura dell'Ab. Antonio Ceruti.* Tipi Fava e Garagnani. 8vo. Bologna, 1870.

This tract (Harting, p. 158) was originally published in *Il Propugnatore*, edited by Zambrini (*q.v.*), and is made up of 58 chapters, occupying 55 pages. It is a treatise on the care and treatment of diseases affecting falcons, hawks, and sparrow hawks.

CHABAILLE, P. *Li livres dou tresor par Brunetto Latini. Publié pour la première fois d'après les MSS. de la Bibliothèque Impériale, Bibliothèque de l' Arsenal, etc.* 4to. Paris, 1863.

According to Harting (p. 137) the chapters of this remarkable old French work that treat of falconry begin on pp. 197, 201, 202, 204. The hunting-birds therein mentioned are (1) *les laniers*; (2) *les faucons que on apèle pèlerins*; (3) *les faucons montains*; (4) *les faucons gentils ou gruiers qui vaut mieux que li autre*; (5) *les girfals*; (6) *les sourpains (sur poing) blanche, et semblable au girfaut*; (7) *les brectons, que li plusor apellent rodio, c'est a dire li rois et li sires de touz autres oisiaus.* See LATINI, BRUNETTO, in this Bibliography.

CHANG HUA (232-300). *Po wu chih.* A compilation of short articles on animal (including avian) life, with an account of birds of prey. 24 x 15.7 cm. Issued in 1592. .G.

CHANGGRAN, DE. *Manuel du Chasseur.* 8vo. Paris (Sangrain et Lamy), 1780.

Not seen.

CHANG TING-YU (1672-1755) AND OTHERS.
Fen Lei Tzu chin. 27 x 17 cm. 1722. .G.

A dictionary of words and phrases used in describing all species of animals, including birds; a Chinese classic.

———. *Tzu shih ching hua*. 24.7 x 16.2 cm. 1727. .G.

Selected extracts on animals, birds, etc.—material intended for a zoological work.

CHARAVAY, ETIENNE (1848-1899). *Etude sur la chasse à l'oiseau au moyen âge; une fauconnerie princière et l'éducation des faucons d'après des documents inédits du XIV^e siècle et du XV^e*. Paris, A. Aubry, 1873. 4to. pp. 6+31. illus. facsim.

Only 100 copies, of which this is No. 43, were published, which seems a pity, since the treatise contains valuable historical accounts of medieval hawking and is illustrated by numerous folding plates of facsimile drawings from the early manuscripts, the best of its kind yet depicted. Many of them have been utilized for the present translation. Present copy a gift to Sourbet.

CHARDIN, SIR JOHN. See SYKES, PERCY.

[CHARDON DE LA ROCHETTE.] *Lettre à J.-G. Schneider sur un manuscrit latin du Traité de fauconnerie de l'Empereur Frédéric II avec restitution des passages qui manquent dans les imprimés*. 8vo. pp. 8. An. VIII (1800), Paris. Extrait, *Magasin encyclopédique*, 6^e Année, I, p. 216.

Very rare. Not seen.

CH'EN CH'IAO (1108-1166). *T'ung chih*. A history, including material on all kinds of animals, including birds. 24 x 15.2 cm. 1896. .G.

References here and there to falconry.

CH'EN JEN-HSI (1579-1636). *Ch'ien ch'io lei shu*. A classified encyclopedia, containing information about animals in general, including birds. 25.8 x 16.5 cm. 1621-28. .G.

CHENG, JO-YUNG (16th century). *Lei chien*. An encyclopedia of 20 main divisions, comprising observations on birds and other animals. 29.5 x 18.3 cm. 1576. .G.

CH'EN MËNG-LEI (18th century) AND OTHERS.
T'u shu chi ch'êng. The largest known printed

Chinese encyclopedia; chapters on the animal kingdom with illustrations. 27 x 17.8 cm. 1726. .G.

This is the *editio princeps* of a famous work, a second copy (edition) having been published in 1885-1888. It contains comments on the use of hunting-birds.

CH'EN YAO-WEN (16th century). *T'ien chung chi*. An encyclopedic work on many subjects, including zoology. 27 x 16.6 cm. 1595. .G.

CH'EN YUAN-LUNG (1650-1736). *Ko chih ching yuan*. An encyclopedia of arts and sciences, giving data on birds of prey and other animals. 1735. .G.

CHENU, JEAN CHARLES (1808-1879), AND DES MURS, O. (1804-1878). *La fauconnerie, ancienne et moderne; supplément au tome deuxième des Leçons élémentaires sur l'histoire naturelle des oiseaux*. Paris, L. Hachette & Cie., 1862. 12mo. pp. 2+176. illus. .W.

This excellent manual is a supplement to the second volume of the authors' *Leçons élémentaires sur l'histoire naturelle des Oiseaux*, 1862, which in its turn precedes their *Ornithologie du chasseur*. Both works are based largely upon Huber's treatise (*q.v.*) and on material extracted from the elaborate *Encyclopédie d'Histoire Naturelle*, Paris, 1850-80, published in 31 volumes.

CERNEL, ISTVÁN (1865-1921). *Nomenclator avium regni Hungariae. A magyar birodalom madarainak nevjegyzéke*. 8vo. pp. 76. Budapest, 1918. .W.

This treatise, by a well-known Hungarian ornithologist, is a systematic catalogue, with introduction, comments, and other text in both Magyar and German on the birds of Hungary. The vernacular, German, and zoological names of each species are given; hence its value to students of medieval ornithology.

CHEVILLE, GASPARD GEORGES PECOU (b. 1821). *Le gibier plumé. Les Oiseaux de la chasse; description; mœurs; acclimation; chasse*. 8vo. pp. 24+194. Portrait, vignette. 34 pls. 62 text figs. table of contents. Paris, n.d. (*ca.* 1856). .W.

Although this is the fourth edition of a rather important treatise, it appears to have escaped Harting and is not listed in the *British Museum Natural History Catalogue*. The work deals fairly well with falcons and falconry.

- CHIN LSIU WAN LUA KU (b. ca. 1500). Published during the Ming dynasty (1368-1644). A classified encyclopedia with material, *inter alia*, on birds, including those that are training for hunting. 24.2 x 16.1 cm. .G.
- CHIORINO, G. E. *Manuale del moderno falconiere; descrizione dei falchi—cattura—educazione—volo e caccia alla selvaggina con gli uccelli di rapina*. Milano, U. Hoepli, 1906. 16mo. pp. 16+247. illus. (Manuali Hoepli.) .W.
A small but well-written and well-illustrated handbook, capable of rendering good service to the amateur falconer.
- CIAMPOLI. *I codici Francesi della R. Biblioteca di San Marco*. Venice, 1897. References to Frederick, his falconers, and the literature known to the Emperor. Quoted by Haskins.
- CIBRARIO, LUIGI. *Della economia politica del medio evo*. 8vo. 3 vols. pp. 457+455+432; indices. Torino, 1842. .W.
An excellent manual on the political economy of the Middle Ages. Vol. II has much to say on the subject of falcons and falconry.
- CODROIPO, FRANCESCO. *Dialogo della caccia de' falconi, astori, e sparvieri*. Vignette. small 4to. pp. 14+90. Tavola. Udine (appresso G. Natolini), 1600.
Harting (p. 148), in his notes on this dialogue between the author's father and another falconer, says that the small treatise is pleasant reading, reminding him of d'Arcussia's *Conférence des Fauconniers (q.v.)*. The conversational form of treating a subject is quite familiar to the student of medieval literature and is not unknown to readers of later productions. A second edition, octavo, per Pietro Lorio, also appeared at Udine in 1614. Different kinds of herons, goshawks, and sparrow hawks are discussed, with their diseases and the proper treatment therefor.
- COHN, WILLY. *Das Zeitalter der Hohenstaufen in Sizilien*. 4to. pp. viii+324. Breslau, 1925. .W.
Good review of Frederick II, with an excellent bibliography.
- COLUMBIA ENCYCLOPEDIA. folio. pp. 1949. Columbia University, New York, 1935. .W.
This useful work of reference furnishes, on p. 663, a very good, abbreviated account of the life of Frederick II and his activities, which includes the *Arte Venandi*.
- CORBALLU, JAS. H. *Forty-five Years of Sport* (1891). Not seen.
- COUES, ELLIOTT (1842-1899). *Handbook of Field and General Ornithology. A Manual of the Structure and Classification of Birds*, etc. Illustrated by 112 rather good woodcuts. 4to. pp. 343. index. London (English edition), 1890. .W.
On the whole, the most practical and best-written work on the biology and anatomy of birds to date. Very helpful in translating the description of the avian anatomy given in the *De Arte Venandi* by Frederick II.
- COX, MAJOR HARDING E. DE FONBLANQUE (1854-). *Coursing and Falconry*. Coursing, by Harding Cox. Falconry, by Gerald Lascelles; with illustrations by John Charlton, etc. Lond., Longmans, Green & Co., 1892. 4to. pp. 14+439. illus. (Badminton Library of Sports and Pastimes.) .W.
Copy No. 145 of an edition of 250 copies.
- COX, NICHOLAS (fl. 1674-1700). *The Gentleman's Recreation: in four parts*. Viz. hunting, hawking, fowling, fishing. Wherein these generous exercises are largely treated of, and the terms of art for hunting and hawking more amply enlarged than heretofore. Also the method of breeding and managing a hunting-horse. Whereto is prefixed, a large sculpture, giving easy directions for blowing the horn; and other sculptures inserted, proper to each recreation. 4th edition to which is now added, A perfect abstract of the forest-laws . . . game above mentioned. Lond., I. Dawks, 1697. v.p. pls. 8vo. .B.
The "forest-laws" have special title page dated 1696.
The first edition of this work was published in London in 1674. Others appeared in 1686 and the best of all about 1815.
- CRAIGHEAD, FRANK (1916-), AND CRAIGHEAD, JOHN (1916-). *Hawks in the Hand; adventures in photography and falconry*. Boston, Houghton Mifflin Co., 1939. 8vo. pp. 12+2+289+1. illus. .W.

CRAIGHEAD. *Adventures with Birds of Prey*. Extract from the *National Geographic Magazine*, Vol. LXXII (No. 1), July 1937, pp. 109-34. .W.

A well-illustrated paper, with interesting text by two informed and practical falconers, useful for comparing American with European falconry.

CRESCENTIO, PIETRO DE (*alias* PIERRE DE CRESCENS and PETRUS CRESCENTIUS) (1230-1320). *Cittadino di Bologna*. Pietro Crescentio Bolognese *Tradatto nuovamente per Francesco Sansovino ... con le figure delle herbe & de gli animale poste a suoi luoghi. Con un'ampio vocabulario delle voci difficili che sono in questa opera, et con i designi de gli stromenti co' quali si coltiva e si lavora la terra*. 4to. 252 fols. + introduction. table of contents, woodcuts, and vocabulary. Venezia, 1561. .W.

Rarely has any medieval writer had to his credit, under his various synonyms, so many translations (in so many languages) of a similar treatise. This famous author wrote a popular work on agriculture. It originally appeared (MS. in Latin) about 1307; then came a French translation in 1337, and an incunable (Italian), folio translation, was first published in Firenze, 1478. The ninth and tenth books of the Italian editions deal with birds in general and with falconry. In addition to the Italian (1478) printing, the *editio princeps*, others appeared as follows: folio, Vicenza, 1490; folios, Venezia, 1511, 1534, 1536, 1538, 1542. The 1541, quarto, entitled *supra*, was followed by another Venetian in 1546; then Firenze, 1605, a quarto; Napoli, 1724; Bologna, 1784; and Milano, octavo, 1805. Numerous German and other Latin and French editions exist, some of them very rare. There are, however, few variants from the original Latin verbiage in the known printings or manuscripts. The Osler Library has a fair copy of the Vicenza incunable (1490) entitled *Opus ruralium commodorum*, 146 fols.

CTESIAS (5th century). This Greek medical practitioner historian lived many years in Persia as Court Physician and was well acquainted with Oriental life, as shown in his *Persica* and *Indica*. .O.

Osler's Catalogue (No. 432) and, in particular, Bahr's *Ctesiae Cnidii Op. Reliquae*, 1824, refer to this author as a naturalist who furnished much information about early falconry in the Far East.

CUMING, E. W. D. See BLOME, RICHARD.

D'AGINCOURT, G. B. L. G. SEROUX. *Storia dell'arte dimostrata coi monumenti dalla sua deca-*

denza nel IV secolo fino al suo risorgimento nel XVI. Prima traduzione italiana. 6 vols. 4to, each of about 500 pages, being descriptions of the 204 engraved plates, most of them full-page size, corresponding to the 2 large folios accompanying the text. Prato, per I Frat. Giachetti, 1826-29. Rare. .W.

This is the Italian edition (not listed by Harting) of a famous work on medieval Italian art, translated from the French original. The text describing and commenting on Plate LXXIII (Vol. VI, pp. 242-53) gives reproductions of some forty figures from the *De Arte Venandi*, including the well-known portrait of the Emperor. It also furnishes a brief but excellent account of the life and times of Frederick II, particularly of his knowledge and encouragement of art. The earlier French edition has title, *Histoire de l'art par les monuments depuis sa cadence au IV^e siècle jusqu'à son renouvellement au XVI^e*. 4 vols. folio. Paris, 1823. Volume III, p. 78, Plate 73, describes the miniatures in the Vatican copy of the *De Arte Venandi*. Geo. Sarton (*Introduction to the History of Science*, Vol. II, p. 578) refers to the foregoing, while Harting (pp. 171, 172, 269) gives a full description, with a woodcut, of these remarkable illustrations. Baron Pichon in his *Traité (q.v.)* also comments at length on their pictorial value.

DAHMS. *Die Jagd mit Beivögeln in Altpreussen*. Danzig, 1905. pp. 6. 4to. (*Sonder-Abzug aus dem 26. Bericht des Westpreussischen Botanisch-Zoologischen Vereins*. Danzig, 1905.) .W.

DAMIRI, KAMAL AL-DINAL (fl. 1370). *Hayât-al-Hawayân (The Life of Animals)*. folio. Verbal foliation. ca. 300 fols. Hundreds of marginal miniatures by Persian painters; lithographed. Teheran, 1869. .B. and .W.

A zoological lexicon in alphabetical order, probably the greatest work of the kind ever written by an Arab. Falconry receives due attention and the illustrations include relative pictures, one especially of a fully equipped falconer, on horseback, with bird on fist, going to the chase. The McGill Libraries have several copies of this work, one especially fine from the Meyerhof Collection in Cairo, another secured by Ivanow.

DANCUS (*Supposititious King of India*). *Le livre du roi Dancus; texte français inédit du XIII^e siècle suivi d'un Traité de fauconnerie également inédit d'après Albert le Grand avec une notice et des notes par H. Martin-Dairvault*.

- Paris, Librairie des Bibliophiles, 1883. 12mo. pp. 2+14+2+135. (Cabinet de Vénérerie, vol. 6.) .W.
- DANCUS. *Libro delle nature degli uccelli fatto per lo re Danchi*; and tr. from the Latin: *Testo antico Toscano messo in luce da Francesco Zambriani*. Bologna, Presso Gaetano Romagnoli, 1874. 12mo. pp. 34+2+71. illus. (*Scelta di curiosità letterarie inedite o rare dal secolo XIII al XVII.*) .B.
Copy No. 27 of an edition of 202 copies.
- DANIEL OF CREMONA. Author of one of the transcriptions in French of a treatise by the Arabic falconers Moamyn and Yatrib (*q.v.*) written for Enzo, son of Frederick II. There is in Clare College Library, Cambridge, a codex (MS. 15, fols. 185-87) on hawks, falcons, and their diseases, composed for Enzo, that may have been written by Daniel. It quotes contemporary and other writers on falconry, including Adelard of Bath (*q.v.*).
- D'ASPET, H. CASTILLON. See SANCHO VI.
- D'AUBUSSON, L. MAGAUD. *La Fauconnerie au moyen âge et dans les temps modernes*. 8vo. pp. 272. index. No illustrations. Paris, 1879. .W.
A complete review of this interesting treatise is furnished by Harting, p. 103, with notes of the author's more important excerpts from other writers—*pièces justificatives*.
- DĀWŪD IBN 'OMAR AL-ANTAKI. 12mo. 23 fols. ? Cairo, Feb., A.D. 1780. .W.
A copy in Syrian-Egyptian *nashi* of a well-known medical compend. There are two *bābs* on falconry. The writer flourished in the middle of the tenth century. It is reviewed in Brockelmann, II, 364, but not mentioned by Harting. The volume in hand is from the famous Meyerhof Library, Cairo.
- DE CUPIS, CESARE. *La Caccia nella Campagna Romana*. small 4to. pp. 42+175. 7 full-page pls. (woodcuts); index. Rome, 1922. .W.
A popular yet correct (though brief) account of ancient and modern hunting around Rome, including falconry. The illustrations are second rate.
- DE FRANCHIÈRES. See FRANCHIÈRES, JEAN DE.
- DELMÉ-RADCLIFFE, EMILIUS C. "Falcon," and "Falconry" in the *Encyclopædia Britannica*. .W.
Excellent (abstracted) reviews of these subjects. The writer was coeditor with Douglas C. Phillott (*q.v.*).
- . *Falconry; Notes on the Falconidae Used in India in Falconry*. Southsea, Mills & Son, n.d. 16mo. pp. 38. .W.
Brief but excellent account of East Indian falconry, with a complete list (both vernacular and scientific names) of the birds used for the chase.
- DEMETRIUS CONSTANTINOPOLITANUS (fl. 1270). *De Cura et medicina accipitrum*. Petro Gillio interprete. Paged continuously and bound with *Aelianus De historia animalium*. 12mo. pp. 527+654. index. In two parts (*libri*). 1562. .W.
The writings of this Greek naturalist appear to be closely allied with the works of another well-known Greek writer on animal life (including ornithology and falconry), Claudius Aelianus (*q.v.*). Probably his literary connection is due to the fact that they were both translated into Latin from approved Greek codices by responsible compilers, Conrad Gesner (*q.v.*) and Peter Gillius (or Gallus). We are indebted to Harting (p. 181) for notes on the works of this ornithologist, one of the oldest writers on falconry. The Greek text was first printed in 1612 by Rigault (N. Rigaltius) (*q.v.*), in his *Rei Accipitrariae Scriptores*. Demetrius begins his falconry chapters by explaining how best to catch, tame, train, and provide for the welfare of hawks. All these directions bear a remarkable resemblance to the written word of the *De Arte Venandi*, e.g., advice to carry the hunting-bird indifferently in either hand. There is, however, no mention of the hood, and, although a supposedly modern improvement, the curtain dependent from the high perch is described, as is the use of the so-called Dutch device of a "sock," in which to envelop the recently caught hawk. There is also a good review of Δημήτριος Πελαγωμένος περί τῆς τῶν ἑράκων ἀνατροφῆς τε καὶ θεραπείας, edited by R. Hercher in *Aeliani varia historia II* (Leipzig, 1866), pp. 333-516. All together, the surviving Demetrius codices form a very important contribution to the literature of medieval ornithology in general and of falconry in particular.
- D'ESTERNO, M. *Du vol des oiseaux, indication des sept lois du vol ramé et des huit lois du vol à voile*. 8vo. pp. 61. 35 figs. in text. 2 fold. pls. table of contents. Paris, 1864. .W.
A useful treatise on bird flight, to be read in conjunction with Huber (*q.v.*) on the same subject. Harting's references (p. 101) are to an edition dated

Paris, 1865. The Wood Library volume is not listed in the *British Museum Catalogue of Natural History*.

DES MURS, O. See CHENU, JEAN CHARLES (1808-79), AND DES MURS, O.

DE THOU. See THUANUS.

DEUDES DE PRADES. *Dels Auzels Cassadors (Les Oiseaux Chasseurs. Poème en Provençal de la fin du XII^e ou commencement du XIII^e siècle)*.

We copy this title from Harting (p. 109), not that the versification itself is of any practical value to the student but because it was contemporary with the *De Arte Venandi* and may have been known to the author of that treatise. Those who wish to go further into the subject are referred to Galvani, *Osservazione sulla poesia de trovate*, Modena, 1829.

Deutscher Falkenorden. Zeitschrift für Falkenerie, Raubvogelschutz und Raubvogelkunde. Angeschlossen dem Reichsbund "Deutsche Jägerschaft" Schriftleitung: Dr. Heinz Brüll. Hamburg. Heft 1-3, 1937. folio. pp. 16 to date. Illustrated by numerous half-tones. .W.

Heft 3/4, 1939, contains the best (superbly illustrated) account of ancient, medieval, and modern falconry issued by any periodical.

This well-edited journal is among the very few magazines entirely devoted to falconry and birds of prey ever published. Its popularity is evidence of the present widespread revival of interest in the noble sport, and it has been of signal service in making the present translation.

DÖBEL, HEINRICH WILHELM (1699-1760). *Neueröffnete Jäger-Practica; oder, Der wohlgeübte und erfahrne Jäger . . .* Leipzig, J. S. Heinsius, 1783. 4 pts. in 1 vol. folio. illus. .W.

Printed in double columns.

DONNET, FERNAND. *La fauconnerie à Anvers*. 8vo. pp. 17. Anvers (Veuve de Backer), 1896. See Thiébaud, p. 285.

DU FOUILLOUX (FOILLOUX), JACQUES (1521-1580). *La Caccia di Giacomo di Foglioso*. Milano, 1615. (See Wood's *Introduction to the Literature of Vertebrate Zoology*, p. 326.) .W.

This is a rare work of this famous French writer on venery (mostly on dogs). The first edition (followed shortly after by many others in several languages) appeared in 1561. They are of interest in this catalogue only because of the glossaries that appear in several of the treatises and because of their

close association in publication with the volumes by Franchières (*q.v.*). All the issues are very scarce.

———. *La vénerie de Jacques du Fouilloux . . . de nouveau revue et augmentée, outre les précédentes impressions*. 2 parts; *La vénerie*, 124 ff.; *La fauconnerie de Jean de Franchières, avec tous les autres auteurs qui se sont peu trouver traictans de ce sujet*. 4to. fols. 455+127. Vignette titles; chapter table of contents. 30 figs. of birds in text. Paris (Claude Cramoisy), 1628. .W.

The chief contributor to this (very rare and) important impression was one of the Cramoisy brothers. Guillaume de Tardif (*q.v.*) gives the chief review of the subject. This edition is badly printed on poor paper; it is the last of the issues associated with the *Falconry* of de Franchières, under whose name Harting (p. 76) insists upon cataloguing numerous treatises that are plainly entitled *La Vénerie de Jacques du Fouilloux*. Beginning with the *editio princeps*, Poitiers (1651), Thiébaud describes (about) 35 printings in French, German, and Italian—the last one being Dessau, 1720. Most of them contain accounts of falconry. There are several others this excellent bibliographer does not catalogue; all of them, as before stated, are very rare.

DUNOYER DE NOIRMONT. *Histoire de la chasse en France depuis les temps réculés jusqu'à la Révolution*. 3 vols. 8vo. Paris, 1867-68.

The third volume is described by Harting (p. 102) as containing a section on falconry full of interesting historical incidents.

DVOŘÁK. *Mitteilungen des Instituts f. östreich. Geschichtsforschung*. 1901.

Has valuable critiques (thirteenth-century art) bearing on the miniatures of the *De Arte*.

EDWARD OF NORWICH, Second Duke of York (1373-1415). *The Master of Game*. folio. pp. 53+1+286. colored front. 51 pls. table of contents. bibliography, glossary, index. London, 1904. .B.

This fine treatise (edited by Wm. A. and F. Bailie-Grohman with a foreword by Theodore Roosevelt) is a copy of the oldest and most important work on venery that has come down to us from medieval times. It was written between 1406 and 1413 and consists mostly of a translation from Gaston de Foix's famous *Livre de chasse*. The present treatise has many interpolations and, although little is said in it about falconry, it is included in this catalogue. Six hundred copies with all the fine plates were printed, this volume being numbered 39.

EGENOLPH, CHRISTOPH. *Waidwerk, Vögel zu fahen mit Raubvögeln, netzeu, stricken, leim*, etc. Strassburg, 1530. 4to.

Quoted by Walter Schlüter.

EGIDIO DI AQUINO. A short treatise in the form of a fifteenth-century manuscript is preserved in Corpus Christi College, Oxford MS. 287, on the species, training, and maladies of birds of prey. .W. Photostat.

This codex begins with falcons and ends with hawks (74^r-78^r fols.), and is of great importance to the translators, as it is especially comprehensive and clear in the differentiation of the varieties employed in Italy. As Haskins points out, Friar Egidius describes the hawks found in Ventimiglia, Slavonia, Calabria, Istria, Sardinia, Germany, and the Alpine regions; among the *astures* are those whose habitat is Tuscany, Lombardy, the March, Apulia, Germany, and Sicily. These notes are followed in this remarkable manuscript by an anonymous addendum, 78^r-84^r fols., entitled *Liber de accipitribus et falconibus et curis eorum*, making use of personal observations but ending by a condensed version of William the Falconer's treatise (*q.v.*). The manuscript is not mentioned by Harting.

ENGELMANN, FRITZ. *Die Raubvögel Europas. Naturgeschichte, Kulturgeschichte und Falknererei*. Neudamm, 1928. 4to. pp. 834. 36 plates and 505 text figures. Gothic text; table of contents, index, and glossary. .W.

One of the most scientific, reliable, and comprehensive works on the subject. It is a pity that this otherwise commendable treatise is printed in Gothic instead of Italian type—a tribute, one may imagine, to its semipopular interest. The review furnished of ancient, medieval, and modern falconry in its various phases is very good. See, e.g., the references to the *De Arte Venandi cum Avibus*, pp. 551-52.

———. *Meine lieblinge, die Falken; erinnerungen und betrachtungen*. Neudamm, J. Neumann, 1925. 8vo. pp. 64. illus. diag. .W.

———. *Erweiterter sonderabdruck aus der Deutschen jäger-zeitung*. Bound with Vögel, H. H., *Die Falknererei*. 1931.

ENGLAND. A collection of all the statutes, from the beginning of Magna Charta, unto this present yere of our Lorde God 1572. Lond., in aedibus Richardi Tottelli, 1572. 8vo. fols. 10+664. .R.

Laws concerning falconry enacted during this period show the importance attached to it.

———. *Das Erste Buch vahet also an und leret paissen [beitzen] und auch den Habich erkenne*. Augsburg, ca. 1472. .W.

Photostat from the only known copy in existence, now in the Preussische Staatsbibliothek, Berlin. The earliest printed book on falconry in any language; author unknown.

ERBACH-FÜRSTENAU, GRAF ADALBERT ZU. *Die Manfredbibel*. folio. pp. xi+58. 14 full-page, half-tone plates; 16 figs. in the text. Leipzig, 1910. .W.

This work forms Band I of the *Kunstgeschichtliche Forschungen herausgegeben vom königlich Preussischen Historischen Institut in Rom*. It contains much that is of little interest to the student of natural history, but furnishes (pp. 36-53) a fair account of the Emperor and his *Falkenbuch*. The illustrations, especially the frontispiece portrait of King Manfred, are excellent.

EVANS, ARTHUR HUMBLE. *Birds*. 4to. pp. 635. 144 illus. index. London, 1899. .W.

This textbook is one of the Cambridge Natural History Series and is of value in identifying the avian species mentioned and pictured in the *De Arte Venandi*. Of still greater importance for this purpose, however, is the next title.

———. *Turner on Birds*. This is a short but succinct history of the principal birds noticed by Pliny and Aristotle, first published by Dr. William Turner, 1544. It is edited, with introduction, translation, notes, and appendix, by A. H. Evans. 8vo. pp. 18+223. index. Cambridge (England) University Press, 1903. .W.

This translation, by the well-known English ornithologist, has been of signal value in the identification of avian species mentioned in the *De Arte Venandi*.

Exposition universelle internationale, Paris, 1889. Fauconnerie; catalogue illustré ... La fauconnerie d'autrefois et la fauconnerie d'aujourd'hui, par P. A. Pichot. Paris, L. Cerf, 1890. 4to. pp. 92. illus. .W.

EYRE, L. B. See NORDENSKIÖLD, N. E.

Falconer, The. The journal of the British Falconers' Club. Nos. 1 and 2; May and December, 1937. 4to. pp. 16+25. (London.) Edited by T. A. M. Jack, the Old Vicarage, Elsenham, Kent.

This is the second magazine, the first being the *Deutscher Falkenorden (q.v.)*, founded in the past

few years, devoted solely to falconry. One may regard them both as indications of a revival of interest throughout the world in the noblest of sports. The cosmopolitan character of the British club which *The Falconer* represents is shown by the selection of the Tiwana of Shahpur, Punjab, India, as president, while the membership includes many names well known to the fraternity in every land where organized outdoor sports are practiced. The contents of *The Falconer* so far issued are of extreme value both to the amateur and to the expert. On the literary side are such excellent contributions as an illustrated paper on a modified form of the Indian hood.

FERNANDES FERREIRA, DIOGO (b. 1546). *Arte da caça de altaneria. Seis partes. Na terceira (trata) dos falcos e sua caça. ... Na sexta da passagem & peregrinacao das aves.* small 4to. Jorge Rodriguez, Lisboa, 1616.

Editio princeps of the first and (perhaps) only Portuguese work on falconry. Excessively rare. Not seen, but advertised for sale by auction (in 1938), London.

———. *Arte da caça de altaneria.* Lisboa, Escriptorio, 1899. 2 vols. in 1. 12mo. (Bibliotheca de classicos Portuguezes.) .W.

Another edition of the preceding item. An interesting and well-written monograph.

FERRARO, GIUSEPPE (1846–1907), editor. *Libro del Gandolfo Persiano delle medesine de falconi publicato per la prima volta.* Bologna, G. Romagnoli, 1877. pp. 153. 12mo. (*Scelta di curiosità letteraria inedite o rare dal secolo XIII al XVII.*) .W.

Printed from an Italian manuscript, apparently derived from the Persian through an unpublished Latin translation. Copy No. 179 of an edition of 202 copies.

Harting (p. 160) says this work is divided into 210 short chapters on hunting-birds, their diseases and treatment, and was probably one of the many works (especially Persian and Arabic) translated for the Emperor Frederick II by his secretary and other learned men in his employ.

FERRER DE VALDECEBRO, ANDRÉS (1620–1680). *Gobierno general moral, y politico hallado en las aves mas generosas, y nobles. Sacado de sus naturales, virtudes y propiedades.* Madrid, M. Alegre, 1670. 8vo. fols. 20+205+15. illus. Extra engraved title page. .W.

———. *Ibid.* Barcelona, T. Loriente, 1696. 8vo. pp. 16+432+32. illus. .W.

FERRIÈRES, HENRI DE. *Le Livre du Roy Modus et de la Royne Racio.* 103 fols. Chambéry (Antoine Neyret), 1486. .W.

The authorship of this very rare and much-prized work on venery is under dispute, there being several other claimants for the honor. Not more than three copies of this first edition are known to collectors. The second printing was issued in Geneva, 1521, and the third in Paris, about 1525. Others appeared in 1526, Paris; 1560, Paris; 1839 (preface by Elzéar Blaze), Paris; 1931 (E. Nourry), Paris. The best edition of this curious work is the most recent one—with notes by Gunnar Tilander—in 2 vols. octavo, published by the *Société des anciens textes français*, Paris, 1932.

The present monograph, with the section devoted to falconry, bears about the same relation to French literature that Berner's *Boke of Saint Albans* holds to English publications on the chase. The mystic title—King Method and Queen Reason—seems well chosen.

FEYERABENDT, SIGMUNDT. *Neuw Jag und Weydwerck Buch, etc.* Frankfurt a/M. folio. 1582.

In part, from the French of Jacques de Fouilloux. Quoted from W. Schlüter.

FILASTORI, A. U. *Falconeria moderna; guida pratica per addestrare alla caccia alcune specie di Falconidi aggiuntavi la pesca col cormorano; compilazione sui trattati stranieri piu recenti di A. U. Filastori. Nuova ed. totalmente rifusa.* Torino, S.T.E.N., 1908. 12mo. pp. 257. illus. .W.

———. *Ibid.* 2d edition. Torino, n.d.

A brief review of the subject, with bibliography and other useful information. The first edition was (probably) issued in Torino, 1895.

FISHER, MAJ. CHARLES HAWKINS (?1826–). *Reminiscences of a Falconer.* Lond., J. C. Nimmo, 1901. 8vo. pp. 14+188. port. pls. .W.

A modern account of the noble sport; well illustrated.

———. *Modern Falconry.* 8vo. Offprint or separate from the *Transactions of the Cotteswold Naturalists Club*, Nov. 1889, pp. 39–70. illus. frontispiece from Wolf-Knox, *Game Birds and Wild Fowl.* .W.

An informative compilation; in it are told a number of interesting, original tales of English falconers and falconry.

FLEMING, HANS F. VON. *Der Volkommene Teutsche Jaeger darinnen die Erde Gebürge Kraeuter und baeume, Waelder, Eigenschaft der Wilden Thire und Vögel*. . . . folio. illus. with copper plates. Leipzig, 1719.

Other editions, in which remarks on falconry are chiefly compiled from d'Arcussia (*q.v.*), were published in 1723 and 1749. Most of the falcons the author describes were imported from Holland, probably from Valkenswaard. Cf. Harting, p. 50.

FLEMING, JOHN ARNOLD (1871-). *Falconry and Falcons; the Sport of Flight*, with foreword by Sir Iain Colquhoun of Luss. . . . illus. with 48 photographs of hawks taken by distinguished bird photographers. Lond., Country Life, Ltd., 1934. pp. 4+1+113+1. port. pls. 4to. .W.

Copy No. 130 of an edition of 350 copies, with author's autograph. The illustrations are fine and the text is scientific and informing—a distinct addition to the literature.

FOIX, GASTON DE. See PHEBUS.

FOLKARD, HENRY COLEMAN (1827-1914). *The Wild-fowler; a treatise on ancient and modern wild-fowling, historical and practical*. 2d edition. Lond., 1864. 8vo. pp. 22+398. illus. .W.
Extra engraved title page.

FOUILLOUX, JACQUES. See DU FOUILLOUX (FOUILLOUX).

FOYE, G. *Manuel Pratique du fauconnier du XIX^e Siècle. Contenant tout ce qu'il faut savoir pour dresser les faucons et autours à la chasse au vol des perdreaux, faisans, canards, lièvres, lapins, etc.* illus. 4to. Paris, 1886.

One of many semipopular treatises on falconry dealing, in this instance, with the sparrow hawk and the goshawk, used chiefly to hunt small mammals, such as rabbits.

FRANCHIÈRES, JEAN DE. *La fauconnerie; de nouveau revue, corrigée et augmentée, outre les précédentes impressions*. Paris, La Boutique de l'Angelier, chez C. Cramoisy, 1621. 8vo. fols. 4+127+5. illus. .W.

———. *Ibid.* Second copy. Paris, 1628. Bound with Jacques Du Fouilloux, *La vénerie*, 1628. .W.

Harting (pp. 75-76) and Thiébaud (pp. 427 *et seq.*) give a full account of the variety (in title) and contents of numerous editions, among them Poitiers, 1567; Paris, 1585, 1602, 1613, 1614, 1618, 1627; also by another Paris publisher in 1621, 1624, and 1628. Although so frequently printed and reprinted, it is among the rarest of French treatises on falconry. It is often bound with *La Vénerie* of Jacques du Fouilloux (*q.v.*) and *La Vénerie* of Guillaume Tardif. The Wood Library has a fine, vellum-bound copy of the 1621, Paris edition, with several minor falconry items bound in.

FRANDOIÈRES, JEAN. *De la fauconnerie*. Paris, 1607.

Not seen. Quoted in *Deutscher Falkenorden*, Heft 3, p. 46, as in Berlin Staatsbibliothek.

FRATI, CARLO (1863-1930). *Re Enzo e un'antica versione francese di due trattati di falconeria* (in Casini, Tommaso, 1850-, ed. *Miscellanea Tassoniana*. 1908. pp. 61-81). .W.

Excellent review and French translation of two early manuscripts relative to medieval falconry.

FREDERICK II, EMPEROR OF GERMANY (1194-1250). *Reliqua librorum Friderici II imperatoris, De arte venandi cum avibus, cum Manfredi regis additionibus. Ex membranis vetustis nunc primum edita. Albertus Magnus De falconibus, asturibus & accipitribus*. Augustae Vindelicorum, 1596. 16mo. pp. 16+414+1. illus. .B.

This is the earliest Latin printing of the two-book manuscript of the famous *De Arte Venandi* in the Vatican Library. Evidently Harting (pp. 167-68) was not aware of the now well-established fact that Velsler was the author of this title. The (extremely rare) copy in the McGill Library has a folding plate depicting Frederick II enthroned, with attendants kneeling before him and presenting his favorite hawks. This treatise ends on p. 358, the remainder of the volume being occupied with the interpolated work of Albertus Magnus, whose title is given *supra*.

According to Harting (p. 168), the Emperor's treatise was printed with the Latin version of Tardif's *Fauconnerie* (*q.v.*) published at Geneva in 1560 and at Bâle in 1578; but this statement has been recently disproved. It is to be hoped that ere long the proposed Latin edition (with notes and comments) of the two-book Vatican manuscript will be completed and published by Professor Strohl, of Zürich, who has been engaged on the task for several years. All the other printings are so scarce as to be practically inaccessible. See also editions of Schneider and

Schöpffer listed below. For ready reference the Wood Library of Ornithology has secured a photograph of the original McGill copy.

FREDERICK II, EMPEROR OF GERMANY. *Reliqua Librorum Friderici II. Imperatoris de Arte Venandi cum Avibus: Cum Manfredi Regis additionibus: ex membranaceo codice camerarii primum edita August. Vindelici. 1596, nunc fideliter repetita et annotationibusque iconibusque additis emendata aequè illustrata. Accedunt Alberti Magni capita de falconibus asturibus et accipitribus quibus annotationes additit suas Io. Gottl. Schneider, Saxo. Eloquent. et Philolog. Professor. 2 vols. Tomus I. 4to. pp. 17+201, front. I-III plates of avian anatomy. Lipsiae, 1788. (Bound with) Tomus II. 4to. pp. 3+231, front. plates IV-VI. Lipsiae, 1789.*

The Wood Library has a photostat (British Museum) copy of this excessively rare treatise, only one original copy of which is known in America. It is in reality a very important, emended second edition of Velsler's (*q.v.*) transcript of the two-book edition of the famous *De Arte Venandi cum Avibus*, MS. Pal. Lat. 1071, without the illustrations. This manuscript has already been noticed in the present translation. Harting (p. 165) evidently did not know about the well-established ascription of authorship to Marcus Velsler. This emended copy of the first two books of the *De Arte Venandi* contains not only the (usual) addition or interpolation on hawks and falcons by Albertus Magnus but also a treatise on the "Nature of Animals" by Aelianus. There are about forty fairly good illustrations, mostly on the anatomy of birds, a good index, and numerous valuable notes, all in Latin.

———. *Bücher von der Natur der Vögel und der Falknerei mit den Zusätzen des Königs Manfred; aus dem Lateinischen übersetzt von H. Schöpffer. Berlin, P. Parey, 1896. pp. 16+212. illus. folio. .W.*

The translators have already acknowledged their indebtedness to this admirable translation by father and son Schöpffer of the two-book edition of the *De Arte Venandi*. It is amended by a good glossary and large drawings of ten species of hunting-birds. There is also a description of falcons with a *History of Falconry in the Nineteenth Century* by Dr. Ernst Schäff. The ornithological writings of this famous falconer have been fully discussed elsewhere in the present translation of his unique monograph, the *De Arte Venandi cum Avibus*. See "Manuscripts and Editions," pp. lvii-lxxxvii of this volume.

FREEMAN, GAGE EARLE. *Practical Falconry; to which is added, How I Became a Falconer. Lond., H. Cox, 1869. 8vo. pp. 8+89. .W.*

The author of this small book, who, writing under the pseudonym "Peregrine" in *The Field*, did much to interest his readers in the decadent sport of falconry. The treatise is out of print and should not be confused with another rare volume that Freeman wrote in 1859 with F. H. Salvin.

FREEMAN, GAGE EARLE, AND SALVIN, F. H. (1817-1904). *Falconry: Its Claims, History, and Practice. To which are added remarks on Training the Otter and Cormorant, by Captain Salvin. 8vo. London, 1859. .W.*

A rare book by two, indeed three, practical falconers. It is well worth perusal. See also SALVIN.

FRIDERICH, C. G. *Naturgeschichte aller deutschen Jagdvögel, etc. 8vo. pp. 10+660. 20 colored pls. Stuttgart, 1849. .W.*

The McGill Libraries have six editions of this excellent ornithologist's works on German birds, most of them with useful comments on and information regarding falcons and falconry, this being the rare first edition. The fifth and sixth editions appeared in 1905 and 1923, respectively.

FUERTES, LOUIS AGASSIZ (1874-1927). *Falconry, the Sport of Kings. Excerpt from the National Geographic Magazine, Dec. 1920. 4to. pp. 429-67. Washington, D.C. .W.*

One of the best popular expositions of ancient and modern falconry, written by a famous American artist and profusely illustrated by his own drawings in color and in black and white. Fuertes was, on the whole, the most successful illustrator and lifelike portrait painter of birds the United States has produced. His avian drawings adorn the pages of many textbooks and magazines.

G., J. J. See GRANDJEAN, J. J.

GALLEGERIS, BERNARDINO. *Lo Strucciero di ... dove si discorre del modo di conoscere, allevare e ridurre gli uccelli rapace all'uso della caccia, e come si curino li loro mali. Libro tre. 12mo. Venetia, 1646.*

A useful but, unfortunately, very rare little treatise. Lastri (*Biblioteca Georgica*, p. 58) calls this author Gallevari. (Harting.)

GANDOLFO. *Libro del Gandolfo persiano delle specie de' falconi*. Pubblicato da G. Ferraro, Bologna, 1877. See FERRARO, GIUSEPPE. .W.

GATTI, ALESSANDRO. *La Caccia: poema, heroica, nel quale si tratta pienamente della natura e di gli affetti d'ogni sorte de fiere, col modo di cacciarle e prenderle*. In Londra, appresso Gio. Billio, 1619. small 8vo.

Not seen. This versification is of interest mainly because it is the only Italian treatise on hunting known to have been published in London. It is dedicated to a famous patron of falconry, King James I.

GERARDUS FALCONARIUS. The chief information we possess of this one of Frederick II's falconers is found in Albertus Magnus' *De Animalibus*, cap. 19 and 20. There is, also, a codex in the Vatican Library, MS. Req. Lat. 1446, in which (fols. 76-77) most of cap. 19 appears. .W.

GESNER (GESSNER), CONRAD (1516-1565).

The Osler Library possesses one of the finest and most complete collections of *Gesneriana* in existence. Osler says of him that this "Father of Bibliography" was "not only the best naturalist among the scholars of his day but of all men of letters he was the pattern." From the Osler and Blacker libraries we choose a few short titles of most value to students of medieval falconry and bird lore.

———. *Lexicon Graeco-Latinum*. folio. Basilea, 1545. .O.

———. *Bibliotheca universalis sive catalogus*. folio. Zürich, 1545. .O.

———. *Icones avium omnium quae in historia avium . . . describuntur*. pp. 126. index. Figuri, 1555. .B. and .O.

———. *Historiae animalium*. 4 vols. in 3. folio. Zürich, 1551-58. .B.

———. *Historiae animalium*. Ed. Secunda . . . folio. *auctior atque emandatior*. 5 vols. in 3. Vol. 3 is entitled *De avium natura*. Index in seven languages. Frankfort, 1617-21. This enormous monograph has over 2,000 woodcuts. .B.

There are several other printings shelved in the Wood Library.

GIACOSA, P. *Magistri salernitani*. pls. 28-33. Torino, 1901.

Valuable treatise on medieval art.

GIGLIOLI, ENRICO HILLYER (1845-1916). *Primo resoconto della inchiesta ornitologica in Italia. Parte seconda. Avifauna Locali*. small 4to. pp. 693; no illus. index. Firenze, 1890. .W.

This treatise, that includes the two *Elencos*, was also published by the same author in 1881 and 1886. Together they form a useful and reliable record of Italian birds. Since species are described and catalogued in the present work by provinces and regions, it has proved very helpful in identifying the avifauna mentioned and pictured in the *De Arte Venandi*.

GILLIUS, PETRUS (PIERRE GILLES). *De Re Accipitraria Liber*. 4to. Lutetiae, 1612. .W.

It is difficult to assess the share of Gilles as translator of the several works he converted into Latin. This particular item certainly originated with Demetrius of Constantinople (*q.v.*) and ought to be wholly accredited to him, as should also be the *Historia animalium* of Aelian (*q.v.*), ed. Lugd. Batav. 1562, first printed with it and the translations of Rigaltius (*q.v.*) in his *Rei accipitriae scriptores*.

Harting, No. 316, furnishes from the same source the following title:

———. *Alius liber de re accipitraria minus elegans quam superior et multo durior itaque a nobis versus paulo durius et magis constantia causa quod primum verteramus*.

However, we must not deny to Gillius a knowledge of the noble art of hunting birds by means of birds.

GIOLI, GIUSEPPE. *Caccie utili e Caccie dannose*. 12mo. pp. 8+311. index. Bologna, 1912. .W.

A sensible review of hunting, including falconry. This small work includes an account of legislation affecting the chase and a chapter on methods of capturing birds and other animals.

GIORGI (GIORGIO), FEDERICO. *Libro di M. Federico Giorgi del modo di conoscere i buoni falconi, astori e sparavieri, di farli, di governarli, & di medicarli, con una aggiunta nel fine della medesima materia*. Woodcut. Tavola. Vinegia, Gabriele Gioliti de' Ferrari, 1558. 16mo. pp. 112. .W.

The copy in hand has early script notes. There is no example of this or any other edition in the *British Museum Catalogue (Natural History)*, attesting the extreme rarity of all the printings. This work is prob-

ably the second edition of this historically important treatise, the first (very rare) bearing date 1547, also published in Venice. Harting (see his index and p. xxvi) persists in spelling the author's name now Georgi, now Giorgio, and again Giorgi. But we cannot find the first of these synonyms.

GIORGI (GIORGIO), FEDERICO. *Libro di M. Federico Giorgio, del modo di conoscere i buoni falconi, astori, e sparavieri, di governarli, & di medicarli, con una aggiunta nel fine della medesima materia.* 12mo. pp. 8+68. Tavola, pp. 64-68. Supplement: *Tratto della cura de' cani.* Brescia, 1595. Appresso P. M. Marchetto. no illus. vignetted title. .W.

This printing of many editions (all very rare) of this popular and useful little treatise was not seen by Harting or Schneider but is catalogued by Kreysig as his No. 322. The first edition, which Turberville admits gave him considerable assistance, was published in Venice, 1547. The second edition, according to Schlegel, appeared also in Venice, in 1567. Another printing, the only one known to Schneider (No. 234), was published at Venice in 1573.

———. *Libro di M. Federico Giorgio, del modo di conoscere i buoni falconi, astori e sparavieri; di farli, di governarli, & medicarli con una aggiunta nel fine della medesima materia.* 12mo. pp. 136. Tavola, woodcuts, one on title page. Brescia, 1607. Press of P. M. Marchetto. .W.

This variant has the usual supplement, a *Trattato della cura de' cani*, and is continuously paged 128-36. Bound with it (often the case) are Francesco Carcano's *Dell'arte del strucciero*, Brescia, 1607 (q.v.), and Cesare Manzini's *Ammaestramenti per allevare, pascere, & curare gli uccelli ...* Brescia, 1607.

The Giorgio described above was not seen by Harting but it is cited by Schlegel as No. 194.

———. *Libro di Federico Giorgio, del modo di conoscere i buoni falconi, astori, e sparavieri, de farli, di governarli, & medecarli. Con una aggiunta nel fine della medesima materia.* With 9 small woodcuts in the text. There is a supplement, *Trattato della cura de' Cani.* 16mo. pp. 4+136. index. Milan, 1645. .W.

This printing (the smallest format of them all) is sometimes cited as the sixth edition; it is more likely the seventh or eighth. For example, Kresig lists (p. 153) a Latin version: *Libellus de cognoscendis bonis falconibus*, dated 1547, and there are doubtless others not seen by nor known to the present translators.

GIOVANNI, TITO SCANDIANESE. See SCANDIANESE, TITO GIOVANNI.

GOMMER, PIERRE ET FRANÇOIS DE. *L'Autourserie de Pierre de Gommer et son frère.* 8vo. Chalons-sur-Marne, 1594.

First edition of an early and important French work on falconry by two brothers who were both practical falconers. Very rare.

———. *De l'autourserie*, etc. 8vo. Paris, 1605.

Rare. A reprint of this edition was published in 1608.

———. *De l'autourserie*, etc. *Nouvelle édition revue et annotée par Henri Chevreuil d'après l'édition de 1608.* 8vo. Aubry, Paris, 1877. Only 100 copies were printed on laid paper.

———. *De l'autourserie.* This is another printing, small 8vo, based on the edition of 1594. It was, according to Harting, p. 80, also issued by Aubry, in Paris, 1878.

GOODWIN, GEORGE C. "Winged Monarchs of the Air." Excerpt from *Natural History*, pp. 51-61, June 1935. .W.

This offprint gives fine portraits of accipitres in the form of black-and-white reproductions of excellent photographs.

GORI, PIETRO (1854-). *Caccia, falconeria e uccellazione; studi e bozzetti con facsimili di antichi disegni.* Firenze, B. Seeber, 1901. 12mo. pp. 4+322. illus. .W.

A brief summary is given of the chief facts about the chase in general, of birds (pp. 104-308), and of falconry (pp. 84-98) in particular.

GRANDJEAN, J. J. *Secrets, anciens et modernes, de la chasse aux oiseaux, contenant la manière de fabriquer les filets, les divers pièges, appeaux, etc.; l'histoire naturelle des oiseaux qui se trouvent en France; l'art de les élever, de les soigner, de les guérir, et la meilleur méthode de les empailler ...* par M. J. J. G. 2d edition. Paris, Roret, 1838. 12mo. pp. 8+328. illus. .W.

The subjects treated in this useful little manual are well described in the title. It has fairly good illustrations and brief descriptions of the birds related to falconry.

GROHMAN, WM. A. *Sport in Art.*
Not seen.

GURNEY, JOHN H. (1819-1890). *Early Annals of Ornithology*. 8vo. pp. 240+4. map and text figs. London, 1921. .W.

A useful treatise for the student of falconry and ornithology.

HALLER, CONSTANTINE. *Ochóta s' Sokolami i Yastrbami* (transliterated Russian title, *Hunting with Falcons and Hawks*). St. Petersburg, 1885.

This is one of the very few Russian treatises entirely devoted to falconry. Harting (pp. 189-93) tells us that it is divided into twelve chapters. The author says that the principal obstacle to the modern revival of the sport in Russia is the absence in that country of professional falconers. Chapters 2-10 list and describe the principal Russian birds of the chase—the falcon proper or peregrine (*Sokol*); gerfalcon (*Krechet*); the goshawk (*Yastreba*); and the red gerfalcon or saker (*Krasnii Krechet*). In addition to these (chapter 3) is the *lanner* (called in Persia the *saker*) or *Balaban*. In chapter 4 one reads about the peregrine (*Sokol*); in chapter 5 the Eleonora falcon (*Chernyui*); chapter 6, the hobby (*Opetsi*), although this name is sometimes given to the merlin; chapter 7, the merlin (*Derbnik*). Chapter 8 is devoted to short-winged hawks (*Ystreba*); chapter 9 to the goshawk (*Velikii yastreba*); chapter 10 to the sparrow hawk or "little goshawk" (*Malii Yastrebi*). Chapter 11 tells how to procure, tame, train, and care for hunting-birds. This chapter is illustrated by figures of hawk's furniture, swivels, jesses, blocks, etc. Chapter 12 furnishes advice and information regarding outdoor exercise and employment of trained birds, with pictures of hoods. The most interesting portion of Russian monographs on the use of birds of prey is the discussion of the work done by the various kinds of eagles. Of these there were probably at least three species: the golden eagle (*Aquila chrysaetus* Linnaeus); the so-called spotted eagle (*Aquila clanga* Pallas, *Aquila naevis* Brisson), and Bonelli's eagle (*Aquila bonelli*). The smaller species were, as a rule, employed to hunt other birds, the larger varieties for chasing mammals. Not infrequently hunting-falcons were utilized for all kinds of prey, avian and mammalian.

HAMMER-PURGSTALL, JOS. FREIHERR VON. *Falknerklee, bestehend in drey ungedruckten Werken über die Falknerey*. Nähmlich: 1) *das ist: das Falkenbuch*. (Auf das Ambrosiana zu Mailand.) 2) *das ist: die Habichtslehre*. (Auf die k.k. Hofbibliothek zu Wien.) 3) *Kaiser Maximilians Handschrift über die Falknerey*. (Auf die k.k. Hofbibliothek zu Wien.) No. 1 ist aus dem Türkischen und Griechischen verdeutscht

und in Text und Übersetzung heraus gegeben. The entire volume is: *In dreihundert abdrucken*. 8vo. 5 leaves+pp. 32+115. Wien, 1840. .W.

The Greek text occupies (with notes by Dr. von Eichenfeld) pp. 81-88, the German translation, pp. 89-93. The original Arabic transcript, with corrigenda, occupies 50 leaves. The remainder of this very valuable, useful, and extremely rare treatise is filled by the Introduction, the replicas of the two German manuscripts, annotations, indices, a bibliography, and corrections. The title *Falknerklee* or "Falconer's Three-leaf Clover" (trefoil) is symbolic of the combinations—three codices in one volume. This *Falkenbuch* has been identified as the *Baz Nama* of Mahmud ibn Muhammed (q.v.)

———. *Ibid.* Wien, Hartleben, 1840. .W.

One of an edition of 300 copies. Wanting frontispiece of Pesth (1840) edition.

HAMPE, KARL. *Deutsche Kaisergeschichte in der Zeit der Salier und Staufer*. 4te Auflage. 4to. pp. 8+294. index. table of contents. Leipzig, 1919. .W.

An excellent account of the career, works, and times of the Emperor Frederick II is given on pp. 218-81.

HAREWOOD, HARRY (pseud.). *A dictionary of sports; or, Companion to the field, the forest, and the river-side, containing explanations of every term applicable to racing, shooting, hunting, fishing, hawking, archery, etc. etc., with essays upon all national amusements*. Lond., printed for T. Tegg & Son, 1835. 12mo. pp. 6+365. illus. .W.

Under "Falconry" (pp. 122-25) there are fairly good definitions and a glossary of falconry terms, as well as notes on sixteenth- to nineteenth-century items pertaining to the noble sport.

HARMONT, PIERRE. *Le miroir de fauconnerie ou se verra l'instruction pour choisir, nourrir, et traicter, dresser et faire voler toutes sortes d'Oyseaux, et les muer et essimer, cognoistre les maladies et accidents qui leur arrivent, et les remèdes pour les guérir*. small 8vo. Paris, 1620.

The author, "dit Mercure," who was falconer to both Louis XIII and Henry IV of France, gives us his experiences of 45 years. The title of the book is typical of many another of the same class, much space being allotted to diseases of birds with elaborate but useless directions how to treat them. The above is the first edition. Harting (p. 83) says that

a second print appeared at Paris in 1634-35, others in Paris 1640 and Rouen 1650—all quartos.

HARTING, JAMES EDMUND (1841-1913). *The Ornithology of Shakespeare, critically examined, explained, and illustrated*. Lond., J. van Voorst, 1871. 8vo. pp. 22+2+321. illus. port. .W.

This is the first of a series of works on falconry by the well-known writer on falconry, the learned Secretary of the London Linnean Society. The frontispiece shows Shakespeare with a falcon on his fist, by T. Wolf. There is an identical edition of the foregoing also in the Wood Library of Ornithology, with the title *The Birds of Shakespeare*.

———. *Essays on Sport and Natural History*. Lond., H. Cox, 1883. 8vo. pp. 10+485. illus. port. .B.

In addition to valuable observations on falconry this treatise contains a review of an Arabic treatise on hawking. *See also* SCHWERDT.

———. *Hints on the Management of Hawks. "The Field" Office*. London, 1884. small 4to. pp. 48. 8 figs. in text. .W.

First edition. A rare and excellent little manual, with its twelve maxims for falconers, that should be carefully read by everyone interested in the regal sport. A much more extended and better edition is that of 1898 (*q.v.*)

———. *Hints on the Management of Hawks*. Second edition, to which is added practical falconry chapters, historical and descriptive. London, 1898. 8vo. pp. 8+268. 10 pls. 42 text figs. table of contents. index. .W.

One of the best textbooks on the subject in English.

———. *A perfecte booke for keepinge of sparrowhawkes or goshawkes*. Written about 1575. Now first printed from the original manuscript on vellum. small 4to. London, 1886. .W.

The original of this work is in the library of W. A. Tyssen-Amherst, Norfolk. The Introduction furnishes a catalogue and review of early English books and manuscripts. Appended to the treatise is a glossary of technical terms used by falconers. Only 100 copies were published, so that this interesting treatise is now extremely rare.

———. The article "Falconry" in *Chambers' Encyclopedia*, new edition. 4to. Edinburgh, 1889. .W.

A well-written account of the sport in all ages.

———. An instructive series of three papers (on Russian falconry) was contributed to *The Field* of August and December, 1890. Their titles are "Trained Eagles," one illustration; "The Eagles Used by Russian Falconers," and "The *Berkut* of Turkestan." .W.

———. *Bibliotheca accipitraria*. A Catalogue of Books Ancient and Modern relating to Falconry with Notes, Glossary, and Vocabulary. (Quaritch) London, 1891. 4to. pp. 28+289. table of contents and index; colored front. and numerous full-page woodcuts; vignette title. .W.

The translators have elsewhere described this valuable monograph and now, once more, acknowledge their indebtedness to this indispensable classic—an annotated list of most of the important printed books and other "source material," in all the literary languages, of our knowledge of falconry. Of course, since the publication (in 1891) of this treatise a great many additional works on the subject have appeared.

———. *English Glossary of Falconry and Polyglot Vocabulary*. 8vo. pp. 23. Quaritch, London, 1891. .W.

Excerpt from the author's *Bibliotheca accipitraria*, with the same date of publication. *See also* BERT, EDMUND.

———. *Recreations of a Naturalist*. 4to. pp. 433. 83 figs. table of contents and index. London, 1906.

A most interesting book, in which falconry is duly treated.

HASKINS, CHARLES HOMER (1870-1936). "The *De Arte Venandi* of the Emperor Frederick II." Offprint from the *English Historical Review*. 8vo. pp. 334-55. July 1921. .W.

The translators have already stated their belief that the late Professor Haskins has written the most informative, most accurate, and most scientific of all the reviews of the two- and the six-book editions of the *De Arte Venandi*. This excerpt and Dr. Haskins' other works on the subject will long stand as the chief source of our knowledge of the Emperor's literary activities.

———. "Some Early Treatises on Falconry." Reprinted from the *Romanic Review*, Vol. XIII, Jan.-Mar., 1922 (No. 1), pp. 1-27. .W.

This reprint deals extensively with such medieval writers as Adelard of Bath, William the Falconer,

- Daniel of Cremona, Archibernardus, Egidio di Aquino, Petrus Falconerius, and a number of anonymous contributors to the literature of falconry. Most of these, including the present offprint, are separately treated in the present bibliography, the works being, as a rule, represented by photographic reproductions.
- HASKINS, CHARLES HOMER. *Studies in the History of Mediaeval Science*. 2d edition. 8vo. pp. 411. Two indices, of proper names and of literary titles. Cambridge, Mass., Harvard University Press, 1927. .W.
This extremely valuable work devotes space (chap. xiv, p. 299) to a brief but excellent account of Frederick II and of the *De Arte Venandi*.
- . *Studies in Medieval Culture*. 8vo. pp. 295. Oxford, Clarendon Press, 1929.
This essay by the late Professor Haskins, although largely republished matter, is important for a study of the life and activities of Frederick II. We understand that the notes, photographed material, etc., in his possession were given to Professor J. Strohl of Zürich, who is at present engaged in a new, critical edition of the works of Emperor Frederick II.
- HEATHERLEY, FRANCIS. *The Peregrine Falcon at the Eyrie*. 4to. pp. 12+73. 29 figs. London, 1913. .W.
An excellent work of reference, with appendix and indices.
- HENNICKE, CARL R. *Die Fänge der in Mitteleuropa vorkommenden Raubvögel*. 8vo. pp. 66 text and 33 photo pls. Dresden, 1900. .W.
The talons of Central European birds of prey (with their specific names) and complete measurements are well portrayed. It is an excellent and useful monograph.
- HENRY VIII. *Various Acts in 14 Chapters on Hawking, Taking Hawks' Eggs, etc.* Black letter. 1562. Personal communication of Mr. Alfred B. Maclay, New York.
- HEYWOOD, THOMAS (d. 1641). *A Woman Kill'd with Kindness; a Tragedy*. n.p, n.d. 16mo. pp. 63. .R.
Contains a hawking scene.
- HICFELT, EBERHARD. *Aucupatorium Herodiorum. Eine Deutsche Abhandlung ueber die Beizjagd aus d. ersten hälfte d. 15 Jahrhunderts*. Facsimile, with colored illustrations. 4to. Vienna, 1886.
Only 220 copies published of this very important manuscript written between 1430 and 1450. Now in the K. K. Hofbibliothek as Cod. MS. Nr. 2457. Not seen.
- HITTI, PHILIP K. *History of the Arabs*. Macmillan, 1917.
- HORREBOW, NIELS (1712-1760). *The Natural History of Iceland*. folio. pp. 20+207. fold. map. table of contents. London, 1758.
This monograph is a translation from the Danish and gives a good account, *inter alia*, of the rapacious birds of Iceland, including the famous white falcon.
- HOWITT, SAMUEL (1765-1822). *The British Sportsman*. 70 plates without text. 4to. London, 1812.
The first series of these interesting pictures (all quite rare) appeared in 1800. They include several very good illustrations of the noble sport of hawking. One of the prints is reproduced in this translation. See p. 377, Plate 127.
- HOWLETT, R. *The School of Recreation . . . Including Hawking*. London, 1684.
From the Maclay Collection and catalogue. Not seen.
- HSIEH WEI-HSIN (13th century). *Ku chin ho pi shih lei pei yao*. 25.7 x 17.2 cm. .G.
This is a Chinese cyclopedia that includes chapters on avian life as well as references to birds of prey and their uses in falconry. The present copy was written about A.D. 1500 and published during the Ming Dynasty (1368-1644).
- HUBER, JEAN (1722-1786). *Observations sur le vol des oiseaux de proie*. 4to. pp. 51. 7 folding copper plates. Geneva, 1784. .B.
This is one of the earliest monographs on the mechanism of flight as seen in birds of prey, particularly dwelling on the differences noted between the progress of long-winged falcons and the shorter-winged hawks. The author remarks that he is preparing a larger work on falconry, but it was never published. The copy in hand was originally in the Ashburnham Library.
- HUILLARD-BRÉHOLLES. *Historia diplomatica*. 1859. See also HASKINS' "The *De Arte Venandi*," *English Historical Review*, 1921, p. 354, footnote 2.
Not seen. Refers to Frederick's falcons and falconers.

- HÜTTENVOGEL (pseud.). *Die Hüttenjagd mit dem Uhu. 2te, verbesserte und wesentlich vermehrte Aufl.* Neudamm, I. Neumann, 1901. 8vo. pp. 90. illus. tab. .W.
- . *Ibid.* Neudamm, 1901. .W.
- HUSAM U'D-DAWLAH TAYMÜR MİRZĀ (d. 1874). *The Bāz-nāmā-yi nāsirī, a Persian treatise on falconry.* Tr. by D. C. Phillott. Lond., B. Quaritch, 1908. 4to. pp. 24+194. illus. .W.
- HUSAYN HUSAYNI. *Ladhhatu'l-Hawwam.* Persian MS. 8vo. 20 fols. ca. 1785. .W.
- This is part of a work by a fairly well-known Persian who wrote on sport, including falconry.
- IBRĀHĪM b. 'ABDĪ'L-JABBĀR AL-KATĪB AL BAGHDADI. folio. A.D. 1490. .B.
- W. Ivanow, who secured in North India this unique item on Persian zoology and falconry, notes that it is the product of an obscure writer living in Baghdad. It is apparently intended to be a sort of supplement to, indeed is bound with, the McGill copy of the *Nuzhat-nama-i-'Alā'ī* (q.v.), and is illustrated by well-drawn pictures representing the natural history of Persia as understood during medieval times.
- ISIDORUS, SAINT (Bishop of Seville). *Etymologiae.* Folio. 264 fols. 2 cols. 38 lines. Augsburg, 1472. .O.
- This rare incunable (Günther Zainer; Proctor 1532) devotes Liber XX, cap. 12, to zoology, including the birds used in falconry. Another edition, 1493, small folio, 100 fols., Proctor 5049, is of less zoological importance, except for its comparative anatomy. It is also in the Osler Library.
- JUAN MANUEL, EL PRINCIPE DON. *Libro de la caza del principe ... que habla de las naturas de las falcones,* etc. 8vo. Madrid, 1879.
- According to the editor of this well-known treatise, Don José Gutiérrez, the original manuscript is the earliest work on falconry written in pure Castilian about A.D. 1325. The book furnishes a full account of the sport in Spain and of the birds employed in it during the early years of the fourteenth century. A German translation (see Harting, p. 115) was made in 1880 by G. Baist, an octavo published at Halle by Neimeyer.
- Kaiser Maximilians Handschrift über die Falknerey.* See HAMMER-PURGSTALL. .W.
- KANTOROWICZ, ERNST (1895—). *Kaiser Friedrich der Zweite.* 3te. unveränderte Aufl. Berlin, G. Bondi, 1931. 8vo. pp. 651. .W.
- . *Ergänzungsband; Quellennachweise und Exkurse.* Berlin, G. Bondi, 1931. 8vo. pp. 335+1. pls. .W.
- This treatise furnishes perhaps the fullest review and most elaborate history of Frederick II and his court so far published. Pp. 332-36 are entirely devoted to the Emperor's *Falkenbuch*. A useful bibliography is appended.
- . *Frederick the Second, 1194-1250; authorized English version by E. O. Lorimer.* New York, R. R. Smith, 1931. 8vo. pp. 28+724. maps. (Makers of the Middle Ages.) .W.
- Bibliography, pref., pp. 25-27.
- . *Federico secondo di Svevia.* Milano, Garzanti, 1939. 2 vols. port. pls. facsim. 8vo. Tr. di Maria O. Merlo dall' ed. originale tedesca *Kaiser Friedrich der Zweite.* .W.
- KARST, A. *Geschichte Manfreds.* Berlin, 1897.
- An intimate account of the King's life with many references to his father.
- KAUP, JOHANN JACOB (1803-1873). *Monograph of the Falconidae.* London, 1849. An English edition of this writer's *Monographien der Genera der Falconidae.* Darmstadt and Jena, 1847-1849.
- The Wood Library does not appear to have this print, although it actually shelves a much greater prize, viz., Kaup's original manuscript, 1847, with the original drawings to illustrate the treatise, that is of prime importance to students of falconry.
- KAYSER, WILHELM. *Der grosse Widersacher.* 8vo. pp. 554. Kassel, 1938.
- A polemic account of the Emperor's conflicts with Papal authority.
- KAZVINI (CAZWINI), ZAKARIYA (13th century). *Aja'iba' l-makhlūqat (Wonders of Creation).* large 4to. pp. 606. colored illus. lithographed. In Hindustani. Lucknow, 1912. .W.
- This modern reproduction of a Hindustani translation from the Persian of an important medieval treatise on cosmography and natural science has been several times republished. A German translation with notes appeared at Leipzig, 1868, by H. Ethé. It contains a fair account of hunting-birds.
- KILLERMANN, SEB. *Die Vogelkunde des Albertus Magnus.* 8vo. pp. 8+100. table of contents. Regensburg, 1910. .W.
- The chief interest to falconers of this essay is its

list of birds known to Albertus Magnus and, by implication, also to the Emperor Frederick II.

- KIRANIDES. *Mysteria physico-medica, ob augustissimos suos natales, ubererrimamq: rerum haud quotidianarum, quibus referta sunt segetem, curioso obtutu quam-maxime veneranda. Multis abhinc seculis Syriacè, Arabicè, & Graecè conscripta; Iterata nunc vice è membranarum Latinis publicae luci exposita.* Frankfurt, Impensis Joannis Justi Erythropili. 12mo. pp. 201+13 (indices). Frankfurt, 1681. .W.

This curious little book contains, among other items of interest to the student of natural history, the names and descriptions of 44 birds with their (generally vernacular) synonyms in Syriac, Arabic, and Greek. Of these species several are birds of prey. An English edition appeared in 1685. Lynn Thorndike (*History of Magic and Experimental Science*) devotes his chapter 46 to this unusual treatise. He believes that the component parts of the work (in Latin) belong to the 12th century at the latest.

- KNIGHT, CAPT. CHARLES WILLIAM ROBERT (1884-). "Ancient Sport of Falconry," *Country Life* (U.S.), No. 37, March 1920, pp. 68-69. .W.

———. *Knight in Africa; Adventures with a Camera in the Veldt.* Lond., Country Life, Ltd., 1937. 4to. pp. 130. port. pls. .W.

- . *Aristocrats of the Air.* With a Preface by Viscount Grey of Falloden. Colored front. 4to. 54 illus. (London) 1925. .W.

Both items are valuable contributions to falconry.

- . *The Book of the Golden Eagle.* 4to. n.d. London. .W.

Excellent account of training one of the male species.

- KNOBLAUCH, J. *Ein Schöne Buchlin von dem Beyssen mit dem Habich uund dem Hund, alle besten uund geschicklicheyt des Federspils treulich unterrichtend uund lernend.* 4to. Strassburg, 1510.

According to Dombrowski, the first edition of this early and extremely scarce work (not in the British Museum of Natural History) appeared at Augsburg, ca. 1478. (Harting.)

- KNOX, ARTHUR EDWARD (1808-1886). *Game Birds and Wild Fowl, Their Friends and Their Foes.* Lond., J. van Voorst, 1850. 12mo. pp. 10+264. pls. .B.

- KÖRNER, M. *Skandinaviska Foglar.* 4to. 60 colored pls. 290 figs. of Scandinavian birds. Lund, 1859. .W.

The best edition of this noted ornithologist's works, with portraits and descriptions of the northern birds used in medieval and modern falconry. It is one of many such general treatises of value to students of falconry but intentionally omitted from the present bibliography. If one were to quote all such titles this catalogue would be needlessly extended.

- KOHLRAUSCH, ROBERT. *Herrschaft und Untergang der Hohenstaufen in Italien.* 8vo. pp. 78. illus. Jena, 1926. .W.

This small book gives a fairly good account of the life and times of four chief Hohenstaufens; there were about ten in all. To Frederick II are allotted pp. 13-31; Manfred, pp. 32-60. There is also a good description of the *De Arte Venandi*, illustrated by a plate.

- KRAENNER, PAUL (1875-). *Falkenheilkunde.* 8vo. 1 pl. pp. 76. Berlin, 1925. .W.

This treatise (a Berlin Inaugural Dissertation) is recommended by Geo. Sarton (*Introduction to the History of Science*, Vol. I, Pt. 2, p. 649) for a study of the *De Arte Venandi cum Avibus* by Emperor Frederick II. Although the pamphlet is mostly devoted to diseases of hunting-birds and their treatment, it is quite worth reading as one of the few rational works on the subject.

- KUO P'Ō (A.D. 276-324). *Commentator.* 40.8 x 26.8 cm. A.D. 1801. .G.

A dictionary of ancient zoological terms (including avian names), reprinted from an early Sung edition (960-1280) and useful for advanced students of medieval ornithology and falconry.

- KURODA, NAGAMICHI. *General survey of Korean and Manchurian birds.* In Japanese. 4to. pp. 95+182. figs. in text. Tokio, 1917. Pub. by the Ornithological Society of Japan. .W.

Valuable for its description of birds used in Korean and Manchurian falconry.

- LAMPERT, KURT (1859-1918). *Bilder-Atlas des Tierreichs. Zweiter Teil. Vogel.* 32 colored pls. with 247 figs. of birds; 70 pp. of figs. in text. pp. 65 text + index and tables. München. 2d edition (1913). .W.

Useful illustrations of birds of the world, with descriptive text, zoological names, etc.; helpful in identifying the birds of *De Arte Venandi*.

- LANDAU, GEORG (1807-1865). *Beiträge zur Geschichte der Jagd und der Falknerei in Deutsch-*

land; die Geschichte der Jagd und der Falckernei in beiden Hessen. Kassel, T. Fischer, 1849. 8vo. pp. 8+340. .W.

The title fully describes the contents of this work on hunting in Germany. The second book (pp. 326-40) furnishes a history of falconry as practiced for many centuries in both Hessen-Darmstadt and Hessen-Cassel.

LANGLOIS. *La connaissance de la nature et du monde au moyen âge*. Paris, 1911.

Quoted by Haskins as given, an account of the scientific frequenters of the Emperor's cosmopolitan court.

LASCELLES, GERALD WILLIAM (1849-1928). *Falconry*. Lond., Longmans, Green & Co., 1892. 12mo. pp. 12+217+413. illus. port. (Badminton Library of Sports and Pastimes.) .W.

An unusually good account of the sport is given, in both its ancient and modern aspects, by an expert falconer. The Wood Library also has on its shelves the large paper edition de luxe, with half-tone illustrations and rearranged pages; small folio, pp. 229-398; 250 numbered copies. This writer contributed "Falconry in Shakespeare's England" to *Shakespeare's England* (Clarendon Press, 2 vols., Oxford, 1916), Vol. II, pp. 351 ff.

———. Excerpt from Cox's *Coursing and Falconry*.

LATHAM, SYMON (fl. ca. 1615). *Latham's Falconry; or, the Faulcons Lure, and Cure in two books, . . . for the instruction of young faulconers in things pertaining to this Princely Art*. Small 4to. pp. 14+147. glossary. table of contents. illus. title of hawk's furniture and portrait of "Haggard Faulcon." London, 1615. Printed by J. B. for Roger Jackson. (Harting.)

First edition of this very rare and valuable work.

———. *Latham's Falconry; or, The Faulcons lure, and cure: in two books. The first concerning the ordering and training up of all hawkes in generall; especially the Haggard Faulcon gentle, The second, teaching approved medicines for the cure of all diseases in them*. Lond., T. Harper, 1633. 12mo. pp. 24+148. .W.

———. *Latham's New and Second Booke of Faulconry: concerning the training up of all such Hawkes as was omitted or left unmentioned*

in his printed Booke of the Haggard Faulcon and Gerfaulcon, namely the Goshawke, and Tassell, with the Sparhawke, the Lanner and Lanneret . . . Hobby and Marlyn in their kindes. Printed by T. B. for Roger Jackson. vignette in title. small 4to. London, 1618. .H.

The writer of these quaint but useful and famous old books, among the earliest of English prints on falconry, was an adept in the noble art. All the editions are scarce.

———. *Latham's New and Second Booke of Faulconry, concerning the ordering and training up of all such hawkes as was . . . left unmentioned in his printed booke of the Haggard Faulcon and Gerfaulcon, etc*. Lond., T. Harper, 1633. 12mo. pp. 22+148+3. illus. .W.

Some writers believe that this (second) edition is the preferable one. Harting notes that smaller and less desirable printings were published in 1653, and 1658; also that there appeared a very scarce work, *The Gentleman's Exercise*, or Supplement to the Bookes of Faulconry, by this author, a small quarto, dated London, 1662.

———. *Latham's Falconry; or the Faulcons Lure, and Cure* (title same as in first edition). Wide 8vo, or small 4to. London, 1663. .W.

The *New and Second Book* of this, the second, edition is more commonly bound with its supplement. Both volumes are printed by Thomas Harper for John Harrison.

All these manuals devote many pages to and give numerous recipes for avian ailments.

LATINI, BRUNETTO. *Il tesoro, nel qual se tratta le cose che a mortali se appartengono volgarizzato da Bono Giamboni Trevisa*. folio. Treviso, 1474. .H.

This is the Italian title of an extremely rare French incunable, the original manuscript of which was composed in Paris at the end of the thirteenth century. There were at least two other editions printed, Venezia, 1528 and 1533. It is an encyclopedia with several chapters on falconry, especially in Part V of Book I, and these were reprinted for private circulation by Mortara (*q.v.*) in 1851.

The best available and most complete edition of the original French text is that of P. Chabaille (*q.v.*).

LE COQ, ALBERT VON (1860-1930). *Von Land und Leuten in Ostturkistan*. 3te Auf. 8vo. 156 text figs. 48 pls. pp. 182. Leipzig, 1928. .W.

There are several plates representing trained eagles and some references to falconry.

- LE COQ, ALBERT VON. *Bemerkungen über Türkische Falknerci*. Lpz., B. G. Teubner, 1913. folio. pp. 12. illus. (*Baessler-Archiv*, Vol. 4, Pt. 1.) .W.
- . Pub. also in *Opuscula ornithologica*; coll. by J. L. Cabanis.
- LEGENDRE, ANDILLY. *Traité des chasses, de la vénerie et de la fauconnerie*. Paris, 1864.
Not seen. Not in Thiébaud.
- LÉON, JACQUES DE. *La fauconnerie de Jacques de Léon*. 8vo. pp. 122. illus. Aix, 1643.
Thiébaud, p. 579, says that only four copies of this interesting *rarissima* are known.
- LEONARDO DA VINCI (1452-1519). *Codice sul volo degli uccelli e varie oltri materie ... trascrizioni e note di Giovanni Piumati; Traduzione in lingua francese di Carlo Ravaisson-Mollien*. Parigi, 1893. pp. 156+6. Facsimile. .W.
The original of this early, very important, and profusely illustrated codex is in the Biblioteca Ambrosiana, Milan.
- LESCUYER, M. F. *Oiseaux de passage et tendues*. 8vo. pp. 116. table of contents. Paris, 1876. .W.
Of some interest to students of falconry, owing to an account of present and past laws in France and elsewhere regulating bird-hunting.
- LEWIS, ERNEST. *In Search of the Gyr-Falcon*. 8vo. pp. 235. 24 photos. map. table of contents.
The posthumous book of this writer, whose real name was Earnest Vesey, is a most interesting and informing volume.
- LING TI-CHIH (16th century). *Wên Hsüan chin Tzû lu*. 25 x 16.8 cm. 1577. .G.
A classified compend on many subjects, including birds and some falconry.
- LINNAEUS, CAROLUS (1707-1778) (also KARL VON LINNÉ). *Journal of a Tour in Dalecarlia [a province of Central Sweden] in 1734*.
Harting informs us that this celebrated naturalist describes in this work his meeting with Dutch falconers who were catching hawks with the aid of a gray shrike. He gives sketches of the hoods and other appliances used by them and expresses surprise that no Swede had learned to trap and train hawks and so, like the Dutchmen, make money by supplying the market.
- The McGill Libraries possess most of the Linnean works on systematic zoology.
- Livre du roi Modus. Le livre de chasse du roi Modus; transcrit en français moderne avec une introduction et des notes par Gunnar Tilander*. Paris, E. Nourry, 1931. 4to. pp. 28+204. illus. (Les Maîtres de la Vénerie, 1.) .W.
Attributed to Henri de Ferrières. Copy No. 962 of an edition of 1,050 copies.
- LOWE, E. A. *Scriptura Beneventana*. pls. xcii.
Contains important references to thirteenth-century art.
- LUBBOCK, RICHARD (1759-1808). *Observations on the Fauna of Norfolk . . . and the Broads*. 8vo. pp. 8+156. map. Norwich, 1845. .W.
An interesting treatise, which has a chapter (pp. 20-31), "On the Remains of Falconry in Norfolk." There were reissues of this (first) edition in 1848 and 1860. A second and enlarged edition with the same title as above (8vo. pp. 36+239. fold. map. 2 pls. table of contents) was published in Norwich, 1879. In it are appendices, by Thos. Southwell, Henry Stevenson, and (most important) Alfred Newton. This printing, as well as the works of the contributors, may be consulted in the Wood Library of Ornithology.
- LUCIANI, S. A. *Il trattato di falconeria dell'imperatore Federico II. Con 4 tavole fuori testo. Archivio storico per la Calabria e la Lucania*, III. Fasc. 2, pp. 153-78. Rome, 1933. .W.
An excellent review.
- MACPHERSON, REV. HUGH ALEXANDER (1858-1901). *A History of Fowling; being an account of the many curious devices by which wild birds are or have been captured in different parts of the world*. Edin., D. Douglas, 1897. 8vo. pp. 54+512. illus. .W.
- MCWILLIAM, JOHN MORELL. *The Birds of the Firth of Clyde*. 4to. pp. 161. table of contents. index. London, 1936. .W.
A good account of early falconry in Scotland is given on pp. 14-15.
- MADDEN, D. H. *A Chapter of Medieval History: the Fathers of the Literature of Field, Sport, and Horses (1924)*.
Not seen.
- MAGAUD D'AUBUSSON, LOUIS (1847-). *La fauconnerie au moyen âge et dans les temps mo-*

dernes; recherches historiques didactiques et naturelles. Paris, A. Ghio, 1879. 8vo. pp. 8+272. .W.

Manuscript letter from author inserted.

MAHMUD IBN MUHAMMED UL BARCHINI. *Baz Nāmā.* This work (No. 1, *Falkenbuch*) was translated into German by Hammer-Purgstall (q.v.). .W.

One of the earliest and most important Oriental treatises on falconry. It was probably a twelfth-century compilation, and first appeared in Arabic, was then transcribed into Persian, and was finally translated into Turkish. It consists of 155 sections, most of them brief, devoted to the usual falconry subjects—descriptions of hunting-birds, their training, their diseases, how to treat them, etc. Schlegel does not, however, think the identification of the hawks and falcons is complete and gives several instances of a mistake in diagnosis.

MANGALI, SID MOHAMED EL. *Traité de vénerie.* See MUHAMMAD IBN MANKALI, SAIYID.

MANZINI, CESARE. *Ammaestramenti per allevare pascere e curare gli uccelli li quali s'ingabbiano ad uso di cantare.* Vignetted title. 16mo. pp. 58+2. table of contents. A few woodcuts. Brescia, 1607. .W.

This little treatise deals chiefly with cage birds, and is usually bound up with the falconry books of F. Giorgio and F. Carcano. The first edition appeared at Milan in 1575. Others were published at Milan, sixteenmo, 1646, and (same date), sixteenmo, Bologna. They contain little of interest to falconers except that the nonrapacious avifauna mentioned were not forgotten (as quarry for his hawks) by Frederick II in his *De Arte Venandi*.

MARKHAM, GERVAASE (1568–1637). *The Gentleman's Academie: or the Booke of St. Albans: containing three most exact and excellent Bookes: the first of Hawking, etc: all compiled by Juliana Barnes [q.v.] . . . now reduced into a better method.* small 4to. London, 1595.

According to Harting (p. 5) Markham published a number of works (that ran through many editions), of which several contain sections on falconry. Of these the editions dated 1631, 1633, and 1655 are of interest, as well as the preceding and the following items.

———. *Cheap and good husbandry for the well-ordering of all beasts and fowls, and for the general cure of their diseases.* 13th edition.

London, G. Sawbridge, 1676. 12mo. pp. 10+146+10. .B.

Binder's title: *Management of Livestock.* This is the only copy of Markham's numerous works (with a Falconry section) in the McGill Libraries.

MAROLLES, GASTON DE. *Fauconnerie et vénerie.* 12mo. pp. 47. Paris, 1922 (*L'Eleveur*). 300 numbered copies.

Valuable because of a glossary of terms used in falconry and venery in general. See Thiébaud, p. 636. Rare.

MARTIALUS, MARCUS VALERIUS (A.D. 40–104). *Epigrammæ.* .W.

There are extant fourteen books of Martial's Epigrams, a number of which contain lines referring to falconry; as in Lib. XIV, No. 216. Martial's name is now and then coupled with that of Pliny and Aristotle as an early naturalist. Consult in this regard Thomas Nash's *Quaternio*.

MARTIN. *The Miniature Paintings and Painters of Persia.* pls. 1–20. London, 1912.

Volbach recommends highly this authority on Islamic art as a source of knowledge in a study of the miniatures of the *De Arte Venandi*. Not seen.

MARTIN-DAIRVAULT, H. *Le livre du roi Dancus. Traité français inédit du XII^e siècle suivi d'un traité de fauconnerie, également inédit d'après Albert le Grand.* small 8vo. pp. 135+xiv; notes and preface. Paris, 1883. .W.

This edition of the oldest known French work on falconry is from a translation, dated August 19, 1284, of Albertus Magnus. Dancus (sometimes spelled Danchus, Dalcus, and Daulcus) is said to have been a king of Armenia with a high reputation as a falconer; but the name is probably mythical. An interesting discussion of this treatise is fully given by the editor.

MARTINEZ DE ESPINAR. *Arte de ballesteria y monteria.* Madrid, 1761.

Not seen.

MARTORELLI, GIACINTO. *Monografia illustrata degli uccelli di Rapina d'Italia.* 4to. pp. 16+679. 6 colored pls. Many text figs. Milano, 1895. .W.

A very good work, useful to students of the *De Arte Venandi*. See Casey Wood's *Introduction to the Literature of Vertebrate Zoology*, p. 453.

MASSINGHAM, HAROLD JOHN (1888-). *Poems about Birds from the Middle Ages to the Present*. 8vo. pp. 415; indices. London, (1922). Preface by J. C. Squire. .W.

Apart from its general ornithological interest, this is among the most useful of the avian anthologies, which it must be remembered appeared in verse.

MEDICI, LORENZO DE' (1449-1492). *La caccia col falcone. Poema del XV secolo. ca. A.D. 1478*.

This is an original poem of forty-five stanzas devoted to hawking in Italy. The celebrated poet describes events in which he took a prominent part, the hawking grounds being favorable localities near Florence. The original manuscript is to be seen in the Laurentian Library.

MEREDITH, (CAPTAIN) R. L. "American Falconry in the Twentieth Century." folio. pp. 100-119. 1936. .W.

Typescript of an unpublished work written by the best-known "practical" falconer in the United States, who has a record of many years' experience. It is well illustrated, including a drawing by Fuertes. Fine photographs are included of his own gerfalcons and peregrines, some imported, others native, which he has flown both in the United States and Canada. The present manuscript, ready for publication, is bound with an article on the general subject of falconry, written for *The Sportsman*, June 1934.

MEYER, PAUL. Several anonymous manuscripts on falconry, dated late 13th century (compilations from Adelard of Bath and Albertus Magnus), have been carefully reviewed by this author. .W.

See *Romania*, Vol. XV, p. 279; Vol. XIII, p. 506. One of these codices, on the care and cure of falcons, is preserved in the library of the University of Cambridge.

MICHELL, E. B. *The Art and Practice of Hawking*. small 4to. pp. 11+291. index. table of contents. 3 full-page photogravures of Lodge's paintings; 10 full-page woodcuts. London, 1900. .W.

Unfortunately this volume is very scarce. It is, in the opinion of the translators, one of the best modern textbooks on falconry in any language. It is filled with valuable information, and the writer quite evidently uses the language of an experienced falconer.

MOAMYN (MOAMIN; MOAMUS; MOHAMIN). *De scientia venandi per aves*.

Sarton (*Introduction to the History of Science*, Vol. I, Part 2, p. 649) says that Theodore of Antioch (q.v.), a Jacobite Christian, having entered the service of Frederick II, translated this title from the original Arabic into Latin. Of its five books the first three were essays on birds and falconry. See also DANIEL OF CREMONA; cf. Harting, *Bibliotheca Accipitraria*, pp. 72, 181, and 205.

MODUS, ROY. *S'ensuyt le livre du Roy Modus*, etc. Paris, 1521.

Excessively rare, the only other copy being a part of the Schwerdt collection. The present item is in the Maclay collection.

———. *Le Livre de Chasse du Roy Modus. Transcrit en Français moderne avec une Introduction et des Notes par Gunnar Tilander. Illustré de 51 figures d'après les miniatures du manuscrit français 12399 de la Bibliothèque Nationale*. small folio. pp. 28+204. Paris, 1931. Falconry, pp. 117-195. Glossary, pp. 189-193. .W.

There exists also a rare facsimile by Elzéar Blaze, Paris, 1839. Tilander's comprehensive notes furnish about all that is worth perusal on this subject, in particular that part of it relating to the noblest of sports. See also Ferrières, and Thiébaud, p. 387.

MOMIGLIANO, EUCARDIO. *Federico II di Svevia*. 12mo. pp. 259. table of contents, indices; 17 chapters. 3d edition. Milano, 1937. .W.

Popular account of the Emperor's career. Little said about the *De Arte Venandi*.

MORAIS, CLAUDE DE. *Le véritable fauconnier*. 16mo. pp. 10+144. Paris, 1683. .W.

Harting (p. 86) calls this writer a master of his art and says that the title above is that of the first edition of his treatise, now very scarce. It was reprinted in 1709, also in 1883, as a small quarto of 96 pages, at Paris.

MORTARA, ALESSANDRO DE, CONTE (ed.). *Scrittura antiche Toscane di falconeria ed alcuni capitoli nell'originale francese del Tesoro di Brunetto Latini* [with Ital. version by B. Giamboni] *sopra la stessa materia con annotazione del ... Conte Mortara*. Prato, F. Alberghetti e Ci., 1851. 8vo. pp. 4+50. .W.

Photostat copy from original in Bodleian Library. The selections from Latini's *Il Tesoro* translated by Bono Giamboni.

This title embraces three separate treatises: (1) a Tuscan tract from the original manuscript, entitled

Trattato de' falconi ed altri uccelli di ratto buoni alla caccia, e del modo di ammaestrarli; (2) another of like origin, *Frammento di un trattato della cura delle malattie degli uccelli di ratto, che l'uomo tiene per diletto d'uccellare* (both of these preserved in the Bodleian Library, Oxford); and (3) chapters from Brunetto Latini's *Il Tesoro* (q.v.), with the original French text and an Italian translation by Bono Giamboni printed on opposite pages. The subject of the Mortara contributions to a study of falcons and falconry is also discussed in the present bibliography under TAPP, EBERHARD.

MUHAMMAD IBN MANKALI, SAIYID. *Traité de vénerie; tr. de l'arabe par Florian Pharaon avec une intro. par M. le Marquis G. de Cherville*. Paris, E. Dentu, 1880. 8vo. pp. xi+154 de texte français et pp. 154 de texte arabe. .W.

Autograph of translator on dedication page. This very rare work, chiefly on falconry, is not listed by Harting. It furnishes in the two languages (with notes) an important addition to the literature of the noblest of sports. See also PHARAON.

MUHAMMAD KARAM'L-LAH. *Shifa'u't-tayr*. [Treatise on Falconry.] Persian MS. 4to. 186 fols. Scribe, Amir 'Alī Sandīlī. 1873. .W.

This is one of the lucky "finds" by Ivanow in North India. He notes that the original was written in Mahkr (Bīrar) between 1680 and 1692. It gives an extended account of the capture, taming, and other care of hunting-birds, falcons in particular. The copy is complete, while several other known codices have missing pages. On the other hand, the original manuscript had illustrations, but the copies are generally without them, the McGill volume among the number.

MUHAMMADA RIDĀ (b. MUHAMMAD YŪSUF). *Dastūru's-sayd (Persian Treatise on Falconry)*. Important. .W.

According to this copy the author wrote the original in 1672-73 and not, as claimed in the Calcutta transcript, during 1662-63. The present manuscript is dedicated to Aurungzeb. There are no references to earlier writers. The size is 16.5 x 10 cm., written in Indian *nasta lig*. Dated May 27, 1817. Divided into 55 *bābs*. Purchased at Amritsar and annotated by W. Ivanow. Badly worm-eaten and part of the manuscript lost.

———. *On Falcons and Falconry*. 8vo. pp. 71. Original written in 1662-63. Dedicated to Aurungzeb. Some pages are missing in the present item, which was transcribed in May 1817.

The original Bodleian copy is (probably incorrectly) dated 1176. .W.

This edition, dealing with all the questions of Persian falconry, is divided into 76 *bābs* (chapters).

MULLENS, WM. HERBERT (1866—), SWANN, H. KIRKE (1871-1926), AND JOURDAIN, F. C. R. *A Geographical Bibliography of British Ornithology from the Earliest Times to 1918*. 8vo. pp. 8+558. London, 1919-20. .W.

To this valuable list was added, by the two first-named compilers, a supplement, 8vo. pp. 17+42. London, 1923. .W.

These two works together constitute, next to Harting, the most comprehensive roster of English works on falconry. It is of especial value since Harting's *Bibliotheca* does not include treatises published after 1891.

NAUMANN, JOHANN ANDREAS (1744-1826). *Der Vogelsteller; oder, Die Kunst allerly Arten von Vögeln sowohl ohne als auch auf dem Vogelheerd bequem und in Menge zu fangen, nebst den dahin gehörigen Kupfern und einer Naturgeschichte der bekannten und neu entdeckten Vögel*. Lpz., Schwickert, 1789. 12mo. pp. 10+206. .W.

———. *Johann Andreas Naumanns mehrerer gelehrten Gesellschaften Mitglieder, Naturgeschichte der Vögel Deutschlands*, etc. 12 vols. 12mo. *Nachträge, Zusätze und Verbesserungen* von J. H. Blasius, E. Baldamus, und F. Sturm. 2 vols. 8vo. 14 vols. in all. Many colored pls. Leipzig und Stuttgart, 1820-60. .W.

This German classic, produced after an enormous amount of toil, by the most famous German ornithologists of their day, gives due consideration to birds of prey and (especially in the first volume of the monograph) to falconry. These Naumannia, including the edition of 1905-9, form the most complete and best-illustrated treatise on the birds of Central Europe.

NELSON, W. *The Laws concerning Game, Hunting, Fishing and Fowling*, etc. London, 1753. A rare item, in the Maclay Collection.

NEWTON, ALFRED (1829-1907). *A Dictionary of Birds*. Assisted by HANS GADOS, R. LYDEKER, C. S. ROY, and R. W. SHUFELDT. 8vo. pp. 12+124+8+1088. map. 700 figs. in text; indices. London, 1896. .W.

This well-known lexicon, which Coues believed to be the best ever written on birds, is useful in many directions for students of ancient and medieval ornithology. It gives a good description of the falcons and hawks used in falconry. There are two printings of the work; a second edition, unabridged, was issued in 1899. See also LUBBOCK, R.

———. *Hawking in Norfolk* (in LUBBOCK, REV. RICHARD [1759-1808]. *Observations on the Fauna of Norfolk*. 1879 . . . appendix, pp. 224-39). .B.

NIGIRI-KOBUSHI. *Shiju Hachi Taka No Zusan (The Fist: or Figures with Descriptions of 48 Kinds of Hawks)*. A.D. 1710.

For an account of this important title we are indebted to Harting (p. 213). The author tells us that falconry was first practiced in China during the Han Dynasty (from 206 B.C.) and the Tang Dynasty from A.D. 618. It was introduced into Japan about A.D. 244 from Hakusai in Korea. Among the birds mentioned by Nigiri-Kobushi are *O-washi-taka*, the great eagle hawk; *Kasumi-taka*, the mist hawk; *Shiwa-butaka*, the white-barred hawk; *No-sushi-taka*, the moor hawk; *Koikiri-taka*, the osprey; *Mushi Kui-taka*, the insect-eating hawk; *Kamamome-nari taka*, the harrier; *Mashiro-taka*, the gerfalcon. It seems that in early Oriental ages the gray shrike or butcherbird (*Mozu*) was trained for catching small birds. For use in hunting there were also utilized *Tobi*, the kite, *Fukuro*, the owl, and *Mimi-zuku*, the eared owl.

NI WAN (16th century). *Ch'un t'an ts'ai yū*. 29 x 16 cm. ca. 1740. .G.

An encyclopedia of animal life that devotes some space to birds of prey and their use in hunting.

NORDENSKIÖLD, NILS ERIK (1869-). *The History of Biology*. Translated from the Swedish by L. B. EYRE. 8vo. pp. 616. London, 1929. .W.

A brief review of the zoology of Frederick II is given by a well-known authority. There is a German translation of this excellent treatise by Guido Schneider (8vo. pp. 8+648. Jena, 1926). It is also in the Wood Library. In Nordenskiöld's tribute (*Biology*, 1929) to the genius of Frederick II he says: "Italian in his upbringing, half-oriental in his habits and mode of thinking, he gathered round him learned men from the East and West. He had the writings of Moamyn and, probably, that of Yatrib, translated from the Arabic under his personal supervision, and appears in general to have systematically collected (other) authorities on the subject. After 30 years of preparation he dedicated to his son Manfred the *De Arte Venandi cum Avibus*,

which is the most noteworthy medieval work on the subject, noteworthy for its independent and scientific spirit even more than for the eminence of the author."

NUÑEZ DE AVENDANO, DR. PEDRO. *Aviso de cazadores y de caza*. Gothic letter. Madrid, 1543.

A rare work, in the Maclay Collection. Another rare edition in the same library bears date, Madrid, 1593.

NUZUL-LAH YĀR JANI. *Bāz nāma*. 4to. 112 fols. 12 colored illus. ca. 1760. .W.

This very scarce Persian manuscript is a complete treatise by the chief falconer attached to the court of Bahadur Shah Muhammed Muazzam, son of the Emperor Aurungzeb. The manuscript in hand is a copy of a still earlier work, based on the writer's personal experiences as a trainer of Persian hunting-birds.

OKE, RICHARD. *The Boy from Apulia*. 8vo. pp. 328. index. London, 1936. .W.

This is a popular but accurate account of the life and antecedents of Frederick II. Part of a chapter, pp. 68-70, is devoted to falconry, and to a brief summary of the Emperor's early career as an amateur falconer and observer of bird life. We quote: "The mind of the young king was no less alert than had been that of the child in Sicily, and Germany must have offered the excitements of novelty. As once from street to street, so now from province to province he wandered. Here were mountains very different from Monte Pellegrino, here were peasants and burghers whose way of life was not that of the merchant Palermitans, here were woods and heaths where one hunted otherwise than in the preserves of the Norman kings. And there was fresh country for hawking, which would always remain Frederick's favorite sport.

"Over hills strangely green he rode out, hawk jessed and leashed to his glove. First there was the joy of riding under clear skies or in grey northern weather (but, if it blew, the hawk must be put on the wing upwind, for only thus could it outclimb its quarry); then the loosing of the long-winged peregrine, for the merlin was smaller and more docile and something of a ladies' bird."

After the chase and capture came "the coupling of leash and jesses; and the point was finished, and then the skilful helter-skelter process could be started all over again. One could make a rousing day of it; and it is surprising that a sport in which field exercise, technical niceties, and crude killing so aptly combined should have become finally obsolete among the English equestrian class. But there is more than jollity and skill and horsemanship to it. It is a lordly sport, flattering the practiser, with the subtlety of

power. There goes the great bird, high and far. Its speed of stoop and flight are variously estimated; it may stoop at the speed of an express train, fly down wind at that of an aeroplane. No material bond connects it with the huntsman. It seems very free. Yet, if the hawk be well-trained and the falconer skilful, it will return, of its own accord or to the lure; and there it is again, obediently back from its wide ranging, perched quietly on his glove. Perhaps this refinement of mastery appealed to one whose ideas were never petty. Frederick was no amateur hunter with birds, reliant on skilled falconers. He knew all about the craft, and already there may have been stirring in that busy brain the idea of writing, one day, a book on birds and hawking."

OLINA, GIOVANNI PIETRO. *Ucceler uccelliera; ovvero, Discorso della natura e proprieta di diversi uccelli, e in particolare di que' che cantano; con il modo di prendergli, conoscergli, allenargli, e mantenergli.* 8vo. pp. 8+77 fols. 66 pls. text figs. index, 6 fols. Roma, 1622. .W.

The illustrations, reminding one of Ridinger (*q.v.*), are extremely well etched and form the best part of this rare and famous work on the capture and subsequent care of birds.

———. *Uccelliera; ovvero, Discorso della natura etc.* Second edition. 4to, with several of the plates re-engraved. Presso Angelo di Rossi, Roma, 1684. .W.

A French translation (*vide* Harting) of the first edition (Didot), octavo, appeared in Paris, 1774.

OPPIANUS (2d century). Several didactic poems have been attributed to this Greek poet, among them the *Cynegetica*, on hunting, and the *Ixentica*, on bird-catching.

Some authorities claim that the first-named was written by another hand in the first century A.D. and that the other cannot properly be attributed to Oppian. Harting refers us to Liber I, pp. 62–66, of *Cynegiticon* for the poet's account of falcons and falconry. The Blacker and Wood collections have six editions (Latin, Greek, English, and Italian) of Oppian's poems on hunting, beginning with the extremely rare *Alieusicon*, Venice, 1508 (not listed by Brunet) to the Italian Salvini (*q.v.*) translation of 1864 (a twelvemo, pp. 22+430, with indices), Milano. The last-named has a valuable glossary of birds and other "game," useful to the student of ancient and medieval falconry. See also SALVINI, A.

OSBALDESTON, WILLIAM A. *The British Sportsman . . . System of Hunting, Hawking, etc.* (London) 1792. Includes a discourse on falconry. From the Maclay Collection.

OSLER, WILLIAM (1849–1919). *Bibliotheca Osleriana*. A catalogue of manuscripts and printed books bequeathed to McGill University. 4to. pp. 36+785. index. Oxford, 1929. .O.

This well-annotated catalogue is of one of the largest and best private collections (illustrating the history of medicine and science) in existence. It contains many rare works on ornithology and falconry and has been extensively utilized in compiling the present translation.

OU-YANG HSUN (A.D. 557–647). *I wen lei chū*. An encyclopedic account of Chinese natural history, including birds of the chase. 28.2 x 18.6 cm. n.d. .G.

PACIUS, JOHANN ERHARD. *Friedrich des Zweyten Römischen Kaisers übrige Stücke der Bücher von der Kunst zu Baitzen, nebst den Zusätzen des Königs Manfredus aus der Handschrift herausgegeben. Albertus Magnus von den Falken und Habichten. Uebersetzt von Johann Erhard Pacius, Diaconus und Rect. zu Gunzenhausen.* small 8vo. pp. 528+ Register. (Ansbach) Onglsbach, 1756. The excipit is in verse. .W. Photostat.

According to Schöpffer (*q.v.*) the author of this very rare treatise, a German translation of the two-book edition of the *De Arte Venandi*, was neither an ornithologist nor a falconer. In the present work he contributed little to the subject in hand except, perhaps, some falconer's terms in a vernacular glossary. The title here given is a transcript from a Wood photograph, correcting a few slight errors in Harting, who, evidently, never saw the original.

PALLAS, PETER SIMON (1741–1811). *Zoographia Rosso-Asiatica, sistens omnium Animalium in extenso Imperio Rossico, etc.* 3 vols. 4to. illus. Petropoli, 1811.

This is not the first work by this celebrated author and traveler on Russian zoology, although it is the *editio princeps* of the one listed above. The second edition is practically identical with the first.

———. *Zoographia Rosso-Asiatica, etc.* 4 vols. 4to. 3 vols. text; one vol. atlas with 48 pls. Petropoli, 1831. .B.

In Vol. I the *Berkut* (trained eagle), gerfalcon, common falcon (peregrine), lanner, hobby, merlin, goshawk, and sparrow hawk are described, as well as (probably) the albino goshawk, with their relations to falconry in general. The Tartar and Calmuck (as well as the Russian) vernacular names of hunting-birds are given.

P'AN TZŪ-MU (12th century). *Chi tsuan yuan hai*. 26.2 x 17 cm. A.D. 1579. .G.

A classified encyclopedia, with matter descriptive of early Chinese ornithology, including birds of prey and their employment in hunting, at about the period covered by the *De Arte Venandi*.

Paston Letters, 1422-1509. New edition, containing letters hitherto unpublished; ed. by James Gairdner. Lond., 1872-75. 3 vols. facsim. 8vo. .R.

Vol. 3 contains letters from John Paston, Jr., to his older brother, Sir John, requesting a falcon.

PATON, WM. A. *Picturesque Sicily*. New York, 1897. .W.

PEMBER, KARL ALBRECHT (1880-1928). *Some Falconers; the Lofty Order of Falconers This Year 1924*. n.p. 1924. 8vo. pp. 15. illus. .R.

PENNANT, THOMAS (1726-1798). *British Zoology*. folio. pp. 14+162+4. 132 colored pls. (121 of birds). index. London, 1766. .W.

This is the first (anonymous) printing of the many editions of this well-known work. In the fifth edition, of 1812, there are a number of brief passages on falconry. In the companion volumes, *Arctic Zoology*, these references also occur; the most interesting being an account of the capture of gerfalcons in Iceland and the training of eagles by the Tartars. The McGill Libraries have almost a complete collection of Pennant's works, including two unique items.

PERGER, A. R. *Zur Geschichte der Falkenjagd*. Wien, 1859. Not seen.

PETRUS FALCONERIUS. A brief Italian tract, found near the middle of a 15th-century codex preserved in the Vatican Library shelved as MS. Urb. Lat. 1014, fols. 53-56. It was discovered in a copy of Moamyn (*q.v.*). The incipit reads "*Petrus Falconerius aliter dictus Petrus de la stor composuit ista.*"

See Haskins' "Some Early Treatises on Falconry," *Romanic Review*, Vol. XIII (1922), No. 1, p. 26. Otherwise the author is unknown. The Wood Collection has a photo of this tractate.

PFEIFFER, MAX ADOLF (1875-). See VIETINGHOFF VON RIESCH, ARNOLD, FREIHERR VON (1895-), AND PFEIFFER, MAX ADOLF.

PHARAON, FLORIAN. SID MOHAMED EL MANGALI. *Traité de vénerie traduit de l'Arabe par Florian*

Pharaon avec une introduction par M. le Marquis G. de Cherville. 8vo. pp. 11+140. Arabic reprint. pp. 104; table of contents. Paris, 1880. .W.

This volume is No. 153 of 300 copies and is a presentation item autographed by the editor. This rare and interesting treatise describes the methods employed in Syria for the capture, taming, training, and care of birds of prey used for hunting purposes. See also MANGALI, S. M. EL.

PHEBUS (GASTON III DE FOIX, dit). *Phebus des deduiz de la chasse des bestes sauvages et des oyseaux de proye*. folio. 134 fols. Gothic text; double col., 52 lines. 50 woodcuts in text. Paris, ca. A.D. 1507.

This is the *editio princeps* of the oldest large French treatise on the chase (including falconry) after the *Livre du Roy Modus*. It is of interest to the translators because it was composed not later than 1370, and until the works of Du Fouilloux (*q.v.*) appeared (after two centuries had passed) it was the only monograph of the kind available for study. Thiébaud (pp. 727-35) lists 14 editions and commentaries in various tongues of this important contribution to the practice of falconry in the Middle Ages. See also DE FOIX.

———. *Livre de la chasse*. 90 fine facsimile miniatures, from the foregoing. .W.

PHILLOTT, DOUGLAS CRAVEN (1860-). [Translation of] *The Bāz-Nāma-Yi Nāzirī, A Persian Treatise on Falconry*. 4to. pp. 24+194. 25 full-page plates. table of contents. London, Quaritch (1908). 500 copies printed. .W.

Phillott tells us in his translator's introduction that the present treatise was composed by Taymur Mirzā (*q.v.*). A second and perhaps a third edition were lithographed in Bombay. The Wood Library has all these printings. The treatise is decidedly the most comprehensive and best-illustrated work on the subject available in English. See also ANONYMOUS, *Bāz-Nāmā*, and TIMUR MİRZĀ QĀJĀR.

PICARD, ETIENNE. *La Vénerie et la fauconnerie ... d'après des documents inédits*. 8vo. pp. 128. Paris, 1881.

This extremely rare essay describes the hawking exploits of the sport-loving Dukes of Burgundy during the fourteenth and fifteenth centuries, when falconry, next to war, was the chief recreation of royalty not only in France but elsewhere. See Harting, p. 104.

PICHON, JÉRÔME (BARON). *Du Traité de fauconnerie, composé par L'empereur Frédéric II, de ses manuscrits, de ses éditions et traductions.* 8vo. pp. 16. Paris, 1864. .W. Photostat

Baron Pichon, editor of many papers and works on venery, originally wrote most of this admirable review in the *Bulletin du Bibliophile*, pp. 885-900, 1864. Of two copies in the Wood Library, one is a British Museum rotograph.

PICHOT, PIERRE AMÉDÉE (1841-1917). *La fauconnerie en Angleterre et en France à notre époque.* 8vo. Paris, 1865. .W.

Reprinted from the *Révue Britannique*, Oct. 1865. Quoted also by Magaud d'Aubusson (*q.v.*). It formed the basis of Pichot's subsequent little work (twelvemo, 1875, Paris) on *Les oiseaux de sport*, an interesting account of various hawking clubs.

———. *La fauconnerie d'autrefois et la fauconnerie d'aujourd'hui.* See *Exposition universelle internationale, Paris, 1889.* .W.

An even better-known work by Pichot is this report (quarto, 1890) of a conference at the Paris Exposition Universelle, 1889, under the auspices of the Société Nationale d'Acclimation—a volume on *Fauconnerie* well worth examining.

———. *Les oiseaux de sport.* small folio. pp. 206. Many woodcuts, a number full-page. table of contents. Paris, 1903. .W.

This monograph, printed on heavy paper, with a fine, engraved frontispiece displaying the charms of Venus. The work especially celebrates the sporting conference of April 1896 in the Jardin d'Acclimation, as well as falconry at the Exposition Universelle, Paris, in 1900. There are in all fourteen chapters describing numerous events in the history of hunting with birds as seen in many countries.

PIUMATI, GIOVANNI. *Codice sul volo degli uccelli*, etc. pp. 30. London, 1893. .W.

This is a facsimile and translation by Carlo Ravaisson-Mollien of an interesting sixteenth-century manuscript on the flight of birds.

PLASSMANN, T. O. *Das Leben Kaiser Friederichs II von Hohenstaufen.* 8vo. illus. pp. 84. Jena, 1927. .W.

A small work, sparsely illustrated with some unusual pictures, among them a flight of birds taken from the Vatican copy of the *De Arte Venandi*.

PLINIUS, CAIUS SECUNDUS (PLINY THE ELDER) (A.D. 23-79). (*Incipit*) *Plinius secundus novocomensis—Libros naturalis historiae*, etc. folio.

355 fols. 50 lines to a page; no pag. nor sigs. J. Spira, Venice, 1469. .O.

The *editio princeps* of an immortal treatise on animal life, as recognized in Greco-Roman times. The McGill Libraries possess many subsequent copies, printed, written, translated, and excerpted. All the natural history works of the Second Pliny were regarded as of high authority from the days of Imperial Rome through the Middle Ages. Forty-two printings in several languages appeared before 1536. No other work of his has survived. In most editions, birds and (inferentially) falconry are treated in Lib. II, cap. 10. In the list that follows (from the McGill collections) only the more important titles are given.

———. *Naturalis historiae libri tricesimiseptimi.* pp. 357. Venice, 1472. Hain 13089. .O.

Copy of the third edition with fifteenth-century initial letter, representing Pliny presenting his book to the Emperor.

———. *Historia naturalis.* Sweynheym & Pannartz. Hain-Copinger 13090. Roma, 1493. .O.

———. *Historia naturalis.* folio. Andreas Portelia. Hain-Copinger 13094. Parma, 1481. .O.

———. *Historia naturale, di lingua latina in fontina tradocta*, etc. small folio. fols. 4+219; map of Africa; index. (M. Sessa.) Venice, 1513. .W.

———. *Naturalis historiae.* Pars. I-III. 12mo. 4 vols., Vol. I, 1536, fols. 314+48, preface and table of contents; Vol. II, 1535, 303 fols.; Vol. III, 296 fols., 1540; Vol. IV, indices, ca. 200 fols., 1538. Foliated, not paged. Aldus, Venice, 1535-1540. .W.

This is a beautiful, morocco-bound, rubricated copy of the very rare Aldine edition (Brunet, IV, 715), with printer's mark (Anchor and Dolphin) stamped in gold on the front cover of each volume.

This edition is among the handiest—despite its extreme rarity—of all the numerous printings of the *Historia naturalis*.

———. *Historiae naturalis libri XXXVII.* Elzevir Press. 12mo. 2 vols. Lugd. Bat., 1635. .W.

———. *Caii Plinii Secundi Historiae naturalis libri XXXVII—accedit index Studiis Soc. Bipopontinae.* 8vo. 5 vols. Boponti, 1783-84. .W.

———. *Histoire naturelle des Animaux.* Trad. par P. C. B. GUEROULT. 3 vols. (?) Paris, 1803. .W.

———. *Plinius und seine Naturgeschichte*, etc. Jena, 1921. .W.

For the information and benefit of research scholars it may be stated here that in addition to the foregoing (partial) list of the available treatises shelved in the Libraries of McGill University there is a separate collection of over 100 monographs in several languages, most of them rare and out of print, dealing with the *Natural History* of Pliny.

PO CHÜ-I (A.D. 772–846) AND K'UNG CHUAN. *T'ang Sung Po k'ung liu t'ieh*. Work of information about birds and other animals, including the hunting species. 28.5 x 18.4 cm. n.d. .G.

This very early, probably ninth-century, treatise devotes several chapters to avian life, including rapacious birds.

POGGESI, ANGELO. *Della Pisana Caccia Libri II*. Pisa, 1697.

A very rare discourse on hunting, with references to falconry.

POLO, MARCO (ca. 1252–1324). *Book of Marco Polo Concerning the Kingdoms and Marvels of the East*; tr. and ed. with notes by COL. HENRY YULE. Lond., 1871. 2 vols. illus. maps. facsim. 8vo. .R.

Frequent references to falconry in the East and description of the elaborate falconry establishment of Kubulai Khan.

———. *The Travels of Marco Polo*; rev. and ed. with an introduction by Manuel Komroff, illus. by N. F. Lapshin. N. Y. Limited Editions Club, 1934. 2 vols. illus. 8vo. .R.

Copy No. 437 of a limited edition of 1,500 copies signed by the illustrator. Vol. I contains illustrations of Kubulai Khan's falconry expeditions.

POMAY (alias POMEY), FRANÇOIS (1618–1673). *Ein sehr artig Buchlein von dem Weydwerck und der Falcknerey. Traité fort curieux de la vénerie et de la fauconnerie*. Title repeated in reverse order (as subtitles) in French and German. 8vo. pp. 66. A few woodcut tailpieces. Stuttgart, 1886. .W.

In this work 500 numbered copies of reimpresions from early treatises on hunting were published, of which the present example is No. 252. The chapters devoted to falconry include a glossary in (chiefly) French and Latin, making all together a useful little pamphlet. See also POMEY, FRANÇOIS, in which the original source of this treatise is given as Lyon, 1671.

POMEY (alias POMAY), FRANÇOIS. *Traité fort curieux de la vénerie et de la fauconnerie. Réimpression textuelle de l'édition originale*. Lyon, 1671. Illustrated, small 8vo. Stuttgart, 1886. Text in both French, German, and Latin.

This reprint, of some importance, is extracted from the author's *Grand Dictionnaire Royal*, a work that had many subsequent editions—Lyons and Frankfurt, 1676, 1687, 1690, 1701, and 1715; Cologne, 1740.

———. *Le Dictionnaire Royal, augmenté. Seconde édition, enrichi d'un grand nombre d'expressions élégantes; de quantité de mots françois nouvellement introduits; des termes des arts, et de cinquante descriptions; comme aussi d'un petit traité de la vénerie & de la fauconnerie*. 4to. pp. 16+1006+60. Lyon (Antoine Molin), 1671. Vignetted title. .W.

Pages 42–48 of the 60 pages of *Description et termes* are devoted to falconry. The foregoing is entitled the Second Edition, but Thiébaud has not seen the first printing. The German-Latin-French prints are all later editions. See also POMAY, FRANÇOIS.

PONTINI, GIOVANNI. *La cacciagione de volatili*. Venezia, 1758.

Quoted from the Maclay Catalogue. Not seen.

RADCLIFFE, LIEUT.-COL. EMILIUS C. DELMÉ-. See DELMÉ-RADCLIFFE.

RAIMONDI, EUGENIO. *Delle caccie di ... Bresciano libri quatro. Aggiuntovi 'n questa nuova 'mpresione altre cacciae che sperse in altri libri andavano*. 4to. Engraved title. 5 fols. + pp. 512. table of contents. 14 fols. index. 19 full-page engravings. Venice, 1630.

In this important treatise avian species (especially *uccelli da rapina*), falcons, and falconry (pp. 81–175) are given considerable attention. Schneider has, however, a poor opinion of this writer as an original observer. Harting furnishes particulars of an early edition (octavo, Brescia, 1621), probably the *editio princeps*; another is a quarto, Napoli, 1626.

———. *Le caccie delle fiere, armate e disarmate e degl'animali quadrupedi, volatili ed aquatici: opera nuova e curiosa*. small 8vo. Venice, 1785. .W.

RAY (WRAY), JOHN (1628–1705). *The Ornithology of Francis Willughby . . . In three*

books. Translated (from the Latin) into English, with many additions. To which are added three considerable discourses; I. *Of the art of fowling*; with a description of several nets, pictured as two large copper plates. . . . III. *Of falconry*. folio; red and black title-page. pp. 12+441+6. 80 pls. 99 colored figs. of birds. 97 colored backgrounds. London, 1678. .W.

There are two examples of this *Ornithology* in the McGill Libraries, one as described above and the other a unique copy, in the Blacker Collection, with the illustrations hand-colored and the pages red-lined. It is a specially prepared copy presented to the famous diarist, Samuel Pepys, when he was President of the Royal Society, by his friend and fellow member, John Ray. It has Pepys' coat-of-arms on the cover and his bookplate on the last page. In this connection it is to be remembered that the corresponding work on fishes was dedicated by the editor, John Ray, to his friend Samuel Pepys. The copy in the Cambridge *Bibliotheca Pepysiana* has the plates uncolored, and the pages are not decorated. The McGill Libraries have over 25 titles accredited to John Ray, issued between 1670 and 1846, many of which contain references to or descriptions of falconry. The appendix on falconry in the present volume is really made up of abridged compilations from Turbervile (*q.v.*), Latham, and Aldrovandus and is found as a separate publication, folio, London, 1678, with the title *A Summary of Falconry*. Another useful treatise is Ray's *Synopsis Methodica Avium*. In the Wood Library.

RICCI, S. *Studi medievali*. N.S.I., p. 59, 1928. Describing portraits of King Manfred.

RIDINGER, JOHANN ELIAS. [*Chasseurs et fauconnerie*.] A series of 25 engravings. folio. n.d., n.p. (? Augsburg, ca. A.D. 1750). .W.

A brief account of the life and works of this famous artist is given in Meyer's *Conversations-Lexicon*. He had a studio in Augsburg, whence he published hundreds of plates illustrating hunting subjects, many of them falconry scenes. All these series are rare and valuable.

RIESENTHAL, OSKAR VON (? 1831-1898). *Die Raubvögel Deutschlands und des angrenzenden Mittel europas*. 2 vols. 8vo. pp. 21+522. 6 pls. Atlas. 60 colored pls. Cassell, 1876. .W.

One of the best works (by a well-informed falconer) on the general subject, including falconry, in the German language. This atlas of 60 chromolithographs depicts practically all the hunting-birds described in the text. Wood also shelves an *édition de*

luxe with clearer and specially mounted illustrations. In 1889 appeared still another, the fourth, edition, all four nearly identical. This last, also in the Wood Library, is an abbreviated manual (pp. 74), a smaller copy of the larger treatises.

RIGALTIIUS (RIGAULT), NICOLAS (1577-1654). 'Ἱερασάκκοσφιον: *Rei accipitraria scriptores nunc primum editi. Accessit Lutetia, Sumptibus H. Drouart*. 4to. 1612. This editor was librarian to Louis XIII.

The volume (very rare) contains, besides the translation of the Greek originals (*ex Bibliotheca Regia Medicea*), Latin translations of Symmachus and Theodotio, as well as those from the original Greek by Gillius and Thuanus (de Thou). See these writers, under their names in this bibliography.

ROBERTS, EMMA. "A Hawking Party in Hindostan." From a chapter in *The Amulet*, Vol. VI, 1831, pp. 281-294. London. Ed. by S. C. Hall. .W.

Interesting account of Indian falconry (one of many so written) in which, *inter alia*, the writer says (p. 289, note): "hawks were *also* used to assist in capturing gazelles. They attacked their quarry with talons, beak, and wings, thus hindering the escape of the animal until the hunter could shoot it."

ROLLAND, EUGÈNE (1846-1909). *Faune populaire de la France, Noms vulgaires dictons, proverbes, contes et superstitions*. 8vo. 6 vols. Paris, 1877-83. .W.

Vol. 6 of this cyclopedic treatise contains the part (pp. 195-224) given over to falconry, including a useful synonymy of Italian, Spanish, and German words and phrases.

ROWLEY, GEORGE DAWSON (1822-1878). *Ornithological Miscellany*. 3 vols. 4to. 14 parts. London and Brighton, 1875-78. .W.

Two parts of this important serial contain notes on falconry, Part I, pp. 55-60, and Part IV, pp. 213-22.

ROY DANCUS. See MARTIN-DAIRVAULT.

ROY MODUS. See MODUS, ROY; also FERRIÈRES.

RUDRADEVA, RAJAH OF KUMAON. *Śyainika Sāstra*: or Book on Hawking. Edited, with an English translation, by Mahāmahopādhyāya Haraprasāda Shāstri. 8vo. pp. 4+(42)+35. Calcutta, 1910. *Bibliotheca Indica*, n.s., No. 1252. .W.

The foregoing is a reprint in Sanskrit and English of a work ascribed by the editor to the fifteenth or sixteenth century. It is a valuable addition to our collection of works on early Oriental falconry. It was published by the Asiatic Society.

RUSSELL, WILLIAM FLETCHER (1915-). *Falconry; a Handbook for Hunters*; drawings by W. D. Sargent. N.Y., C. Scribner's Sons, 1940. 8vo. pp. 10+180. illus. bibliography, p. 176. .W.

SADRU'D-DIN, MUHAMMAD B. ZABARDAST KHĀN. *Khawassu'l-Haywan*. A treatise on zoology. 8vo. 81 fols. Persian manuscript. A.D. 1720. .W.

The present volume was the author's own copy, with an alphabetical list of animals, including hawks and other hunting-birds, and their vernacular names in Arabic, Persian, and Hindi—an important and rare treatise, for the advanced student.

SAINCTE-AULAIRE, FRANÇOIS DE. *La fauconnerie de ... Divisée en huit parties: avec un bref discours sur la louange de la Chasse et exhortation aux chasseurs*. small 4to. pp. 423. Paris, 1619. (Robert Foüet.)

Extremely rare treatise. *Fide* Harting, an analysis of it appears in *Bref Discours sur la louange de la Chasse*, Louviers, 1888. Also see Thiébaud, p. 796, who calls it "un des plus précieux ouvrages sur la fauconnerie."

ST. JOHN, MAJOR O. B. *See* BLANDFORD, WM. T.

SAINT MARC, C. DE. *See* SOURBETS, G., AND SAINT MARC, C. DE.

SALERNE, FRANÇOIS (d. 1760). *L'histoire naturelle, éclaircie dans une de ses parties principales, ornithologie*. 4to. Paris, 1767. .W.

This work is practically a translation of John Ray's *Synopsis Methodica Avium* (q.v.), published in 1713.

SALNOVE, R. *See* SOURBETS, G., AND SAINT MARC, C. DE.

SALVIN, FRANCIS HENRY (1817-1904), AND BRODRICK, WILLIAM. *Falconry in the British Isles*. 4to. pp. 6+147; index, table of contents, glossary. 24 colored pls. London, 1855. .W.

This work is, on the whole, the best English treatise on the subject, the colored pictures of falcons and hawks and the illustrations of their "furniture" being especially good. The second edition, published in 1873, is considerably amended, but the

plates are not as clear as in this *editio princeps*. Both printings are becoming quite rare.

———. *Falconry in the British Isles*. 4to. pp. 8+171. 28 colored pls., glossary, index. London, 1873. Written in conjunction with G. E. FREEMAN. .W.

Second printing. The present edition has the original plates redrawn and several new ones added. Although the work deals mostly with the noble sport in Great Britain, it is also a compendium of falconry in general, and is regarded by Harting (p. 40) as the "best modern book in English on the art and practice of falconry." The translators have in several instances utilized (as suggestions) the colored plates as black-and-white illustrations.

SALVINI, ANTONMARIA. *Della pesca e della caccia. Tradotto dal greco. Nova editione ... delle notizie per G. A. Greenhill*. 12mo. pp. 22+430; indices. Milano, 1864. .W.

An Italian translation of the well-known poems on venery by the Greek poet Oppian (q.v.).

SANCHO VI (EL SABIO [i.e., the wise king] OF NAVARRE) (fl. 1180). *Los raramientos en general par Don Sancho le Sage, Roi de Navarre, Publiés en l'année 1180. Avec introduction et notes du traducteur*, H. Castillon d'Aspet. 12mo. Paris, 1874.

Harting (p. 111) believes this to be the oldest non-English code of its kind. The hawks used for hunting in Navarre during the twelfth century were the falcon, the goshawk (*Aztor*), and the sparrow hawk (*Gavilan*). They were taken young from the nest, reared in mews (*halconera*), and fed on a paste of meal mixed with the flesh of birds. Less and less of this food was given to the young hawk until she was strong enough to digest a meal, twice a day, of pure beef or mutton. Training began when the bird was about a month old. Until the end of the seventeenth century, Spain, like the rest of the sporting world, annually imported many of its trained birds from Holland.

SARTON, GEORGE (1884-). *Introduction to the History of Science*. 4to. 4 vols. Vol. I, Part 1, table of contents, index, pp. 484, 1927; Vol. I, Part 2, table of contents, index, pp. 485-1251, 1931; Vol. II, Part 1, table of contents, pp. 35+480, 1931; Vol. II, Part 2, table of contents, pp. 482-1251, index, 1931. Washington, D.C., and Baltimore. .W.

This monumental monograph is by far the most comprehensive work on the subject in any language.

The brilliant author furnishes (Vol. II, Part 2, pp. 575-79) an account of the life and labors of Emperor Frederick and a description of the *De Arte Venandi* that are models of concise yet complete information; he notes that the Emperor "devoted the leisure of his busy life to the preparation of a monograph on falconry, which is one of the most elaborate treatises of its kind, and one of the most important zoological works of the Middle Ages."

SCANDIANESE, TITO GIOVANNI. *I quattro libri della caccia di Tito Giovanni Scandianese con la dimostrazione di luochi de Greci et Latini scrittori, etc. Con la tavola copiosissima in fine.* 4to. pp. 164+10 fols. pp. 15. table of contents. Venice, 1556. .W.

This rare and curious book on hunting in general is divided into four parts, of which the fourth deals with birds, hawks, falcons, and the charms of falconry.

SCHÄFF, ERNST (1861-). *Anleitung zum Bestimmen der Deutschen Tag-Raubvögel nach den Fangen (Füssen).* 8vo. pp. 35. 21 text figs. Berlin, 1893. .W.

A brief but well-illustrated monograph on the talons of birds of prey. This subject is of value in a study of the *De Arte Venandi*.

———. *Ornithologisches Taschenbuch für Jäger und Jagdfreunde.* 8vo. pp. 10+193. 18 figs. in text; index. Neudamm, 1891. .W.

Another, second and amended, edition of this treatise, with its many references to falconry, appeared (pp. 12+210; 67 text figs.) in 1905. *The Diagnosis of Birds of Prey by Their Feet* (Berlin, 1893), and the excellent chapter in Schöpffer's treatise (*q.v.*) are among Schäff's numerous contributions to the study of falconry.

SCHIØLER, E. LEHN (1874-1929). *Danmarks Fugle. Med henblik paa de i Grønland, etc.* 2 vols. folio. pp. 552+338. Indices, maps, and hundreds of colored pls. and (colored) figs. in text. Kjøbenhavn, 1925-26. .W.

This is far and away the most complete treatise on Danish birds yet published. It furnishes a complete, well-illustrated account of Greenland falcons and their use in hunting.

SCHLEGEL, HERMANN (1804-1884), ET WULVERHORST, A. H. VERSTER DE. *Traité de Fauconnerie.* Chez Arnz et Co. Atlas superfolio. 16 full-page hand-colored engravings. pp. 8+90 text. Full-page vignetted title. glossary. bibli-

ography. index. Leyden and Düsseldorf, 1844-53. .W.

The senior author of this rare, costly, elaborate, and beautifully illustrated work was a famous (Leiden) ornithologist. His colleague was a well-known Dutch inspector of forests and an experienced falconer. With such a combination it is no wonder that the magnificent monograph in hand was possible. It is, taking it all in all, the finest work on falconry ever published, admirable not only for the beauty of its life-size portraits of hawks and falcons in their natural colors by the best artists of the nineteenth century, but noteworthy because of the scientific accuracy of the text. Owing to the unwieldy superfolio format the Wood Library (also) had made an octavo photostat (British Museum) for use as a ready reference volume. Of the sixteen full-page plates two are of pictures delineating hawking for heron; two others figure lures, jesses, hoods, and other articles of the hawk's furniture; the remainder are remarkable, life-like portraits of hunting-birds by Wolf and Sonderland. Finally, the bibliography furnishes what is lacking in many treatises, a roster of Japanese and Chinese works on falconry.

SCHNEIDER, JOHANN GOTTLIEB, see under Frederick II, second item.

SCHÖPFFER, H. (AND SON), see under Frederick II, third item.

SCHWERDT, C. F. G. R. *Hunting, Hawking, Shooting. Illustrated in a Catalogue of Books, Manuscripts, Prints and Drawings.* Privately printed. Waterlow & Sons. 4to. 3 vols. London, 1928.

A beautifully printed, magnificently illustrated work of over 1,000 pages. Only 300 copies were issued, constituting the most complete, annotated work on hunting ever issued in any language, a bibliography to which the author devoted 50 years of his life. Now very rare and very costly when found, recent quotation being £100 sterling, with a decided upward tendency in price. With Thiébaud (*Bibliographie*) and Harting the subject of falconry is completely covered.

SCOT (OR SCOTT), MICHAEL (1175-1232). *Translacio tractatus primi libri quem composuit Aristoteles in cognitione naturam animalium.*

There is a fragment (German manuscript) of this work, written ca. 1320, in the Osler Library. As before stated, this celebrated scholar visited Frederick II and was by him employed as his astrologer, in translating Aristotle and other works, as well as in writing treatises on natural history. The librarian of the Osler Library, Dr. W. W. Francis, reports the

- following items, also on his shelves: "The *Liber Physiognomiae*, also called *De Secretis Naturae*. Our copy, No. 7490 (Hain 14542) was probably printed at Venice by Rubeus, ca. 1488, and has three relevant chapters: xx, 'De animalibus in genere & in specie' (not as Linnean as it looks!); xxi, 'Divisio capituli de animalibus' (a long string of aphorisms—'Every animal having a lung has a voice' &c, nearly all beginning thus with 'Every animal'); & xxxviii, 'De notitia partium corporis in omni animali' (the hot-, cold-, moist-, dry-ness of the various organs & parts).
 "No. 1756 is a 1648 edition of *Albertus de secretis mulierum*, with the foregoing by Michael Scott thrown in for good measure.
 "No. 7491. The *Mensa philosophica*, Heidelberg, 1489 (Hain 11080) usually attributed to Scott, has a lot about animals but from the *edible* standpoint.
 "No. 238. A fourteenth-century manuscript of Michael's Latin translation of Aristotle's *De animalibus*, Books 1-4 & parts of 5-6 (*vide supra*).
 "No. 83. Avicenna's *De animalibus*, tr. by Michael, Venice, De Gregoriis, n.d. (ca. 1500); Hain *2220; GW 3112."
- SCOTT, WM. HENRY. *British Field Sports*. small 4to. pp. 11+615. Several pls., index. London, 1818. .W.
 Not much (pp. 272-76) in this work about falconry. The author thinks it is a "cruel sport," but lauds badger and otter hunting, especially when the latter is attended by women and children! There is also a copy in the Wood Library of the second edition, octavo, 34 pls., 1820.
- SEALY, ALFRED FORBES. *A Classified List of the Names and Latin Synonyms of British Birds*. 8vo. pp. 6+29 fols. Privately printed, Cambridge, 1853. .W.
 Useful for the present translation. The volume in hand is the author's copy, with numerous manuscript notes by him.
- SEBIZIUS, MELCHIOR. *Fünfzehn Bücher von dem Feldbau*. With woodcuts by Jost Amman. folio. Strassburg, 1588. Other editions, 1592, 1598, and 1607. Quoted from Walter Schlüter.
- SEBRIGHT, JOHN SAUNDERS (1767-1846). *Observations upon Hawking, Describing the Mode of Breaking and Managing the Several Kinds of Hawks Used in Falconry*. 8vo. pp. 2+64. London, 1828. .W.
 A rather rare item, well written, without illustrations, but forming a brief and concise account of the subjects displayed in the title.
- SELINCOURT, JACQUES ESPÉE DE. *Le parfait chasseur, pour l'instruction des personnes de qualité aux vénéurs, Picquers, Fauconniers, etc.* 12mo. pp. 14+390. Paris, 1683.
 Harting (p. 87) says this rare little volume gives sound advice about hawks—they should be used according to the nature of the country over which they are to be flown.
- SENEBIER, JEAN. *Catalogue raisonnée des manuscrits (Genève)*. 1779-80. .W.
 Contains a description of the miniatures in the *De Arte Venandi*.
- SEROUX D'AGINCOURT. See D'AGINCOURT, SEROUX.
- SFORZINO, FRANCESCO. See CARCANO, FRANCESCO SFORZINO DA.
- SHĀHMARDĀN, ABĪ'L-KHAYR. *Nuzhat-nama-i 'Alā'i*. A.H. 807 (i.e. A.D. 1404). .B.
 This title represents one of three complete, extant copies of a celebrated encyclopedia dealing with natural history as known to medieval Persians. The author dedicated his treatise to a then reigning prince that ruled A.D. 1095-1119. The oldest and most complete copy (1304) is in the Bodleian; the second is No. 10 of W. Pertsch's *Catalogues*; the third, in the Blacker Library, is illustrated by well-drawn, colored figures of birds, some of them associated with falconry. Although the present volume is over five hundred years old, it is in a good state of preservation.
 See also IBRĀHĪM b. 'ABDI'L-JABBĀR.
- SHAKESPEARE, WILLIAM (1564-1615). The immortal poet has given us many references to falconry, collected in numerous anthologies. See, for example, Harting's volumes, both published in 1871. .W.
- SHAKESPEARE'S ENGLAND. 2 vols. Clarendon Press, Oxford, 1916. Chapter with quotations on falconry by G. W. LASCELLES. Vol. II, p. 351. .W.
- SHAW, GEORGE (1751-1831). *General Zoology*. 8vo. 14 vols. Only Vols. I-XI are paged continuously. Vols. IX-XIV, *Aves*, by J. F. STEVENS. Many plates. London, 1800-1826. .W.
 There are numerous though brief references in this remarkable work to the use of birds for hunting. Vol. VII (pp. 135-40) furnishes a good account of training hawks for that purpose.

SHEARER, CRESSWELL, F.R.S. *The Renaissance of Architecture in Southern Italy. A Study of Frederick II of Hohenstaufen.* 4to. pp. 184. Numerous illus. Cambridge, England. Heffer & Sons, 1935. .W.

We quote from this author's introduction: "To Frederick II of Hohenstaufen belongs the credit of being the first in modern times to attempt the establishment of a civilisation based on rational principles. Mathematics, natural history and philosophy (and architecture) were his favourite studies. The Emperor's absorbing passion was falconry and his book on this subject has long been recognized as our first zoological treatise written in the critical spirit of modern science." Professor Shearer speaks at some length not only on the Capuan towers—his special subject—but of the Emperor's other building activities, such as the huge but artistic octagonal palace erected by him in Apulia for the housing of his falcons and their attendants—the Castel del Monte. A complete account of this remarkable architectural gem, as well as of other erections by Frederick II, notably those in south Italy, is also given, profusely illustrated, in a special chapter by Dr. Shearer in this translation.

SID MOHAMED EL MANGALI. See PHARAON, FLORIAN.

SIEBOLD, PHILIPP FRANZ VON (1796–1866). *Fauna Japonica.* 6 vols. folio. Birds: pp. 141, 120 colored pls. Lugduni Batav., 1844–50. .W.

The volumes of this (*editio princeps*) very rare treatise have been separately issued. A reprinted and augmented edition, Leipzig, 1934, has also been published, so that this most excellent account (including a complete review of the avian life of the Japanese Empire) is now readily available. A good account of Japanese and Korean falconry is given in this fine monograph.

SIEDEL, FRITZ. *Gefiederte Ritter der Luft.* 8vo. pp. 133. 51 full-page illus., mostly photos by the author. (Berlin 1936). .W.

A good account of German birds of prey, with many references to falconry.

SIME, T. "Frederick II (1194–1250)." A short but excellent account of the works (including his writings) of the Emperor, from the *Encyclopaedia Britannica*. Typescript. .W.

SLAUGHTER, GERTRUDE (1870–). *The Amazing Frederic.* small 4to. pp. 7+397. 13 full-page woodcuts. table of contents; index.

Pen-and-ink sketches by R. H. Taylor. Macmillan, New York, 1937. .W.

This treatise is not only the latest but, in the opinion of the translators, the best popular-scientific account so far appearing in English of the Emperor's political, social, and literary career.

SONNENBURG, LUDWIG. *Zoologisch-kritische Bemerkungen zu Aristoteles Thiergeschichte.* 4to. pp. 2+27. Bonn, 1857. .W.

A good commentary, well worth reading. See also ARISTOTLE.

SOUHART, ROGER FRANÇOIS. *Bibliographie générale des ouvrages sur la chasse; la vénerie et la fauconnerie, publiés ou composés depuis le XV^e siècle jusqu'à ce jour en français, latin, allemand, anglais, espagnol, italien, etc., avec les notes critiques et l'indication de leur prix et de leur valeur dans les différentes ventes.* Paris, Chez P. Rouquette, 1886. 4to. pp. 7+[3]+750+[5]. .W.

Found to be a valuable aid in compiling the present bibliography, although Harting (p. 105) calls it incomplete as to the literature of falconry in English, Spanish, and Italian. See also J. THIÉBAUD.

SOURBETS, GEORGE. *La chasse au vol avec les petites espèces. Notions pratiques de fauconnerie dédiées aux débutants.* 4to. Niort, 1885. .W.

This manual gives instruction in taming and training the small hawks for falconry purposes, especially the sparrow hawk, hobby, merlin, and kestrel. In his later and much larger textbook (*q.v.*) written in conjunction with C. de Saint-Marc, the author goes more thoroughly into this subject, including an account of several of the long-winged falcons. As Harting points out (p. 106), in this conjoint volume the long list of remedies for avian diseases, which takes up so much space in medieval and some modern textbooks, is ignored. Wisely, most of them are regarded as useless if not harmful, and directions are given for curing only a few ailments to which hawks are liable and for which they may be simply and effectively treated.

SOURBETS, G., AND SAINT-MARC, C. DE. *Précis de fauconnerie contenant les indications nécessaires pour affaîter et gouverner les principaux oiseaux de vol, suivi de l'éducation du cormoran.* Niort, L. Clouzot, 1887. 8vo. pp. 2+123+1. illus. .W.

A very good manual with fairly useful plates, especially that picturing the high perch. There is

also a chapter on training the cormorant. See also SOURBETS, GEORGE.

SPEZI, GIUSEPPE (1818-1871). *Due Trattati del governo e delle infermità degli uccelli, testi di lingua inediti cavati di un codice vaticano, e pubblicati e con note illustrati dal Prof. Giuseppe Spezi. Tipografia delle scienze matematiche e fisiche.* 8vo. pp. 15+84. Roma, 1864. .W.

The first tract has 41 chapters, pp. 1-56, and the second 21 chapters, pp. 57-70, the remainder, pp. 71-84, being annotations by the editor, who believes the original tracts to have been Tuscan translations of two early Persian works on the care and diseases of birds. The pamphlet is rare, and has considerable interest for falconers.

Sportsman's Dictionary. First chapter devoted to hawking. London, 1735.

STABLER, ROBERT M. "A Glance at Modern Falconry." Excerpt from the *General Magazine and Historical Chronicle*. U.S.A. pp. 304-311, 1937. .W.

This is an admirable though brief account of the subject—one of many contributions to periodical literature that mark a revived interest throughout the world in the royal sport.

STEFANO, CARLO. *L'agricoltura e casa de villa. Nuovamenta tradotta dal Cavaliere Hercule Cato. Con tre tavole una appartenente alle medicine.* small 4to. pp. 511; indices; woodcut title. 3 pls. Vinegia, 1581. .W.

In this work on agriculture, pp. 472-82 are devoted to falconry. The treatise seems rare, as it is not mentioned by Harting. The author is described as a "gentil'huomo francese," and he is included in Thiébaud's *Bibliographie*.

STEVENS, J. F. See SHAW, GEORGE.

STEVENSON, M. *The Twelve Months. Chapters on Falconry.* London, 1661.

An exceedingly rare item. Only three known copies. From the *Maclay Catalogue*.

STORMER, HEINRICH. *Waidwerck; Vögel zu fahen mit Raubvögeln*, etc. Augsburg, n.d. (ca. 1530.) Quoted by Walter Schlüter.

STRADANUS (OR STRADA), JOHANNES. See STRAET, JAN VAN DE.

STRAET, JAN VAN DE (1536-1605). *Venationes ferarum, avium*, etc. Edit. a Philippo Gallaeo. 4to. 101 pls. Antwerp [? 1566]. .B.

A very rare treatise by a Flemish artist. A still rarer edition having an English title (folio, with 97 [of 105] pls. Antverpiae, 1580) is also in the Blacker Library. A curious but useful description of falconry is given in both works. The latinized name of the author is Johannes Strada or Stradanus. These monographs are not mentioned by Harting.

STRASSER, H. *Über den Flug der Vögel.* 4to. pp. 263. 33 figs. in text; table of contents. Jena, 1885. .W.

One of a numerous class of monographs on the flight of birds, a subject of much interest to falconers. It is a separately published, repaged reprint from the *Jenaische Zeitschrift für Naturwissenschaft*, Bd. XIX, N.F. XII (1885); and is one of the most elaborate and important of its class—one that Frederick II would have delighted to read!

STRUTT, JOSEPH (1742-1802). *The Sports and Pastimes of the People of England.* New edition, with copious index by William Hone. Lond. Printed for T. Tegg & Son, 1834. 8vo. pp. 68+420. illus. .R.

SUSEMIHL, JOHANN CONRAD (1767-1837). *Abbildungen der Vögel Europas.* 4to. 36 Lieferungen. pp. 116+16. 106 colored pls. Stuttgart, 1839-51. .W.

This fine, rare atlas contains, among other interesting falconry items, 100 pages by Schlegel (*q.v.*) devoted to falcons and falconry, illustrated with 44 colored plates by Joseph Wolf. A variant copy of it is also in the Wood Library.

SWAEN, A. E. H. *Enkele Mededeelingen omtrent de Valkenjacht.* 4to. pp. 47. Seven full-page plates. Amsterdam (1926). Published by the *Koninklijke Oudheidkunde Genootschap te Amsterdam*.

These notes on falconry, ancient and modern, form an address given by Professor Swaen at the annual meeting of the Society in 1925. The published paper is mostly illustrated by reproductions of pictures in miniature from the large atlas of Schlegel and Wulverhorst, the *Traité de fauconnerie (q.v.)*, altogether an admirable presentation of the subject.

———. *De Valk in de Iconographie.* square 8vo. pp. 35. 10 half-tones. Maastricht, 1926. .W.

This pamphlet gives the history of falconry as portrayed by paintings of Saint Bavo (with descriptive text) reproduced with other holy pictures and images.

SWAEN, A. E. H. *De cura accipitrium*. A medieval Latin treatise by Adelard of Bath. Amsterdam, 1937. 8vo. pp. 28. .W.

An excellent review of the work, the earliest treatise on falconry in Western Europe, issued during the reign of Henry I of England. See also ADELARD OF BATH.

———. *De Valkerij in de Nederlanden*. 8vo. pp. 132; many full-page plates; table of contents. Thieme and Co., Zutphen, Holland, 1937. .W.

Decidedly the best treatise on the subject yet published by a Dutch writer. Professor Swaen is unquestionably the most informative of recent Netherlands writers on falconry.

SWANN, H. KIRKE. *Synoptical List of Accipitres (Diurnal Birds of Prey)*. 4 parts. 8vo. pp. 64. Index to Genera. London, 1920. .W.

A most useful catalogue, giving a full description of species and subspecies.

SWANN, H. KIRKE (1871-1926), AND WETMORE, ALEX (1886-). *Accipitres (Diurnal Birds of Prey)*. Parts I-XVI. 2 vols. Index to Vol. I. London (Wheldon and Wesley), 1924-1938. small folio. Illustrated by many full-page plates in color by H. Grönvold. Also numerous text figs. .W.

The most complete monograph of its kind in any language. It furnishes an accurate and elaborate description of all birds of prey—except the owls. The rarer species are shown in full-sized color plates. On the death of Kirke Swann, completion of this fine monograph was undertaken by Dr. Wetmore, who has the matter well in hand. The original colored drawings for this treatise are in the Wood Library of Ornithology.

SYKES, PERCY. *Sir John Chardin's Travels in Persia, with an Introduction by Sir Percy Sykes*. folio. pp. 228. 9 illus. colored front.; table of contents. London, 1927. .B.

This edition, printed by the University Press, Cambridge, and limited to 975 copies on vellum (of which the present copy is No. 448), gives an interesting review of Chardin's travels, including an account of hunting in Persia at the end of the seventeenth century. There are brief remarks on birds and falconry.

SYMMACHUS, AQUILA ET THEODOTIA. *Epistola Aquilae Symmachi et Theodotionis ad Ptolemaeum regem Aegypti de re accipitraria, Catalana lingua*. 4to. Lutetiae, 1612.

This commentary is the only Catalan treatise on falconry in the present bibliography. It is of some importance for its own sake (de Noirmont believes it to be the earliest treatise in the vulgar tongue) and because it is quoted by Albertus Magnus therefore of *De Arte Venandi* interest. It deals with the usual subjects popular in medieval works on falconry, a description of hawks used in hunting, the diseases of the same, and the remedies to be employed for their relief. Probably both the alleged writers and "rex Ptolemaus" are mythical personages. The Maclay Collection has a fourteenth-century manuscript on falcons, veterinary medicine, etc., in Latin, addressed by these three writers to Ptolemy, King of Egypt, that differs somewhat from the present manuscript but otherwise closely follows it.

TAPP, EBERHARD. *Waidwerck und Federspiel. Von den Habic uund Facken . . . tregern vast notig uund zu wissen nutzlich. Durch Eberhardum . . . Burger zu Coln*. Strassburgh, 1542. 4to. pp. 72. illus. .W.

This title is copied from a facsimile reprint said to have been made for and edited by Count Alexander Mortara, although there is no *internal* evidence in the facsimile to justify these conclusions. It was published in Stuttgart and sold at Schaible's *Verlagsbuchhandlung*, n.d. The Wood Library example (one of 250 copies on heavy, hand-made paper) bears number 212. It may be described thus: quarto; 36 fols.; 2 full-page pls.; table of contents and chapter headings; vignетted title; in Strassburgh by M. Jacob Cammer Lander; anno 1542. Woodcut of a falconer on horseback, falcon on right wrist, and attendant dog repeated on verso of the folio preceding the Register. This interesting collection of chapters on falconry includes directions how to tame, train, and dress hunting-birds both in the mews and when afield; also how to treat their various ailments. For further information regarding this and similar translations of the kind, for which we are much indebted to Conte Alessandro Mortara, cf. Harting, pp. 157, 158, 159. All the Mortara printings are very rare.

TARDIF, GUILLAUME (TARDIVUS, GUILLELMUS). *Le livre de l'art de fauconnerie et des chiens de chasse*. 4to. 41 fols. (Antoine Verard.) woodcuts. Paris, 1492.

This is the *editio princeps*. There are numerous subsequent editions, among them that of Antoine Verard, Paris, 1506; J. Trepperel, Paris, 1506; Pierre de Sainte Lucie, Paris, 1530[?]. Printings of this title, Paris, Philippe le Noir, are often bound with *La fauconnerie* of Jean de Franchières (q.v.), 1567, 1585, 1602, 1607, 1613, 1614, 1618, 1624, 1627, 1628. Latin translations were published at Venice and Geneva in 1560; at Bâle in 1578. This information is taken from Harting, pp. 71 and 72.

TARDIF, GUILLAUME. *Le livre de l'art de fauconnerie, etc. Avec une notice et des notes par Ernest Tullien. Réimprimé sur l'édition de 1792 [sic].** 2 vols. (parties). 8vo. pp. 32+153; illus. with notes, appended to seconde partie. pp. 39-111. Paris, 1882. .W.

This popular treatise is, as indicated by the title, divided into two major parts, the first dealing with hawks and falconry in general and the second devoted to hunting-dogs. Turberville (*q.v.*) is said to have utilized much of Tardif's compilation in his own treatise. In his turn Tardif borrowed largely from de Franchières, the *De Arte Venandi*, and similar sources. All the early Tardif printings are rare.

* So reads our numbered copy 105, but Harting is, as usual, correct; his copied title is 1492; and the printer is wrong.

———. *De Arte Accipitrum una cum Frederici Imperatoris de Arte Venandi cum avibus, et regis additionibus.* 8vo. Geneva, 1560.

According to Harting there were (p. 164) other octavo editions of the Emperor's famous treatise issued under the name of Guillelmus Tardivus as editor: Basle, octavo, 1578, and Augsburg, 1598 (*vide* Lallement)—three in all. On the other hand, Thiébaud (*q.v.*) questions the existence of any of these three printings. To settle the matter, the translators wrote the librarians at Basle and Geneva and they confirmed the statement of Thiébaud; there are no such editions in their collections; indeed, they never heard of them; hence these three titles may safely be deleted from this bibliography.

TEMPESTA, ANTONIO. *Aucupationis multifariae effigies.* 16 copperplates, oblong 4to, by N. J. Visscher, Amstelredami, 1609.

This is an early edition of a work many times reprinted. The Maclay Collection has a copy dated Rome, 1605. It is especially interesting because of the plates illustrating hawking methods. Thiébaud (pp. 876-83) catalogues no less than 30 titles, issued in the sixteenth and seventeenth centuries, the majority on falconry and profusely illustrated. Almost every one of these books deals with some phase of animal sport, and they are now quite rare.

THEODORE OF ANTIOCH. Frederick's (Syrian, Jacobite Christian) astrologer and secretary who (Sarton, II, p. 59) translated for him at least one Arabic or Persian treatise on falconry. He is sometimes, owing to his literary and other talents, referred to as "The Philosopher."

The Wood Library has a rotograph (Corpus Christi College, Oxford MS. 287) in which Theodore is mentioned by name in connection with the treatise of Moamyn, certainly translated by him for the Emperor. See also Haskins, *English Historical Review*, July 1921, p. 349.

THIÉBAUD, J. *Bibliographie des ouvrages français sur la chasse.* small folio. pp. 9+1039+2; indices; illus. by 40 facsimiles. Paris, 1934. .W.

By far the best-annotated bibliography of French works on sport from the fifteenth century onward. It may be regarded as a supplementary and much-improved edition of Souhart, since it includes in its catalogue not only French titles of works on hunting since the fifteenth century but many more in other languages and outside that period. Says the author: "nous avons également admis les auteurs grecs, latins et byzantins de l'Antiquité et du Moyen." Yet *Fauconnerie* does not appear as fully represented as it should have been. See also SCHWERDT.

THIENEMANN, F. A. L. (1793-1858). *Einhundert Tafeln colorirter Abbildungen zur Fortpflanzungsgeschichte der gesammten Vögel.* 2 vols. folio. 1 vol. plates; 1 vol. text. pp. 17+5+432; of the 100 pls. 10 are colored. Leipzig, 1845-56. .W.

This (uncompleted) rather rare monograph (mostly oölogical) incidentally describes hunting-birds, but not to the length found in some of the author's other writings. In *Rhea*, Heft 1, pp. 44-98 (Wood Library), he gives an account of the lanner and the saker as hunters in Central Europe.

THOMPSON, D'ARCY W. (1860-). *On Aristotle as a Biologist, with a Proemium on Herbert Spencer.* 8vo. Oxford, 1913. .O.

A valuable contribution to the study of an ancient Greek naturalist as compared with a modern philosopher. See ARISTOTLE.

———. *Glossary of Greek Birds.* 8vo. pp. 16+216. front. London and Dundee, 1895. .W.

This useful treatise contains many excerpts from Pliny, Aristotle, Aelian, and other naturalists of antiquity. It is of considerable value in a study of the *De Arte Venandi*.

THOMSON, J. ARTHUR (1861-1936). *The Biology of Birds.* small 4to. 59 drawings. pp. 436. 9 pls. index; bibliography. London, 1923. .W.

A valuable, semipopular work of great assistance to any student of medieval ornithology.

THORNTON, (COLONEL) T. (1757-1823). *A Sporting Tour through England and Scotland*. 4to. Edinburgh and Glasgow, 1804.

This book (*vide* Harting, p. 36) contains much practical information on falconry. The author formed a falconers' club, and wrote another work, *A Sporting Tour through France in 1802*, quarto, 2 vols., with an appendix. It is illustrated by a portrait of himself in hawking array, with a picture of his mews at Thornville Royal.

THORNDIKE, LYNN (1882-). *A History of Magic and Experimental Science to 1327 A.D.; and in the 14th and 15th Centuries*. pp. 835+1036+827+767. 4 vols. 4to; indices; table of contents. New York, 1929 and 1934.

This is a monumental, valuable, and important survey to the end of the fifteenth century of subjects included in falconry. The Frederickian or thirteenth century is called the "greatest of centuries"; perhaps it would be correct to call it the "greatest of medieval centuries." During that period Professor Thorndike gives a useful account of every writer who deals with natural history in any of its many phases.

THUANUS, JACOBUS AUGUSTUS (1553-1617). (*Also de* THOU, JACQUES AUGUSTE, and TUANO, JACOPO AUGUSTO.) *Hieracosophion; sive de venenatione per accipitres. Libri duo*. 8vo. Burdegalae, 1582.

The first edition of a well-known poem by a famous, versatile French historian. Of the various printings of this versification (on the art of falconry in Latin hexameters) the quarto of 1735, in which an Italian translation of the original Latin appears with the former in parallel columns, is generally regarded as his best. Harting (pp. 165-66) records a second edition with a Third Book (small quarto, Paris, 1584), also a third edition (small octavo, Paris, 1587). Nicolas Rigault (*q.v.*) in 1612 printed the poem in his *Rei accipitraria scriptores*.

———. *Hieracosophion, sive de re accipitraria Liber III*. 8vo. Vignetted title. pp. 126. Lutetiae, 1587. *Apud Mamertum Patissonium Typographum Regium: In officina Roberti Stephani*. .W.

A poem giving a fair account of falconry. On p. 107 is an indexed list of birds of prey with their Latin and French vulgar names and brief notes on a few of them. Pages 108-19 are taken up with a complementary *Somnium* dedicated to Philipp Huralt, French Chancellor, and some more versification

(pp. 120, 126) in honor of another friend. The most valuable part of this little work is the long and definite list of birds just referred to: *Rapacium avium, quae cicurari possunt et interdum volant, aliae lorariae seu pinnariae, Gallis oyseaux de ceurre; aliae pugilares, Gallis oyseaux de poing. Lorarium numero sunt aquilae et falcones: earum de quibus haec, nomina haec fere sunt*. They include:

"Χρυσαιετος, Aristot. Regia; Plin. Gall. *Aigle faune*. pag. 11; Arist. Plin. 12; Falco Peregrinus, Pellerin, 14; F. Montanus, 16; F. Fugitivus, *Pasager*. Ital., *Traverso*, 17; F. Scythicus, *Tartarot*. 17; F. Nobilis, *Gentil*, 19; F. Ignobilis, *Villain*, 19; F. Teutonicus, Ital. *Tedesco*, 20; F. Lannius, *Lanier*, 20; Haliaeetus, *Falco marin*, 22; F. Tunisicus, *Tunisian*, 23; Hierax, *Sacre*, 24; Buteo, *Gerfault*, 25; F. Punilus, *Esmerillon*, 26; Pugilares Accipitres hi sunt, Fringillarius, *Esparvier*, 28; Astur Jul. Firmico Gallis, *Autour*, 28.

"*Inter accipitres qui κραπτος . . . Aristoteli est, is Plinio Buteo dicitur. Unde palam est injuriam maximam fieri maximo et nobilissimo accipitri ab iis, qui Buteonem interpretantur, Buzart. Nos nomen principi accipitris tribuimus Falconi qui inter accipitres et in re accipitraria principem locum tenet.*

"Capiuntur aut in nido, et Nidularii vocantur, vulgo *Niaix*; aut jam adulti, et Ramales dicuntur, vul. *Branchus*: adultiores, antequam tamen primum deplumentur, Horni seu hornotini sunt, vulg. *Sores* post quam jam annum egerunt, et plumas exuerunt; hos anniculos et deplimatos heic appellamus, vulgo *Muez*."

The author's name is not mentioned in this copy of de Thou.

———. *Il falconiere de ... dall'esametro Latina all'endecasillabo Italiano trasferito, et interpretato. Coll'uccellatura a vischio di P. Angelio Bargeo ... Poemetto pur Latino, similmente tradotto, e commentato. Ozii, e ameni studii de G. P. Bergantini*. 4to. pp. 36+223+50+17. Vignetted title. 1 pl. 1 port. index. Venezia, G. Albrizzi q. Cirol, 1735. .W.

This rather scarce treatise is divided into three distinct sections. The first, a translation into hendecasyllabic Italian verse, deals with falconry in general. The second part, also in verse, describes a method of catching birds by the use of birdlime, still practiced in Italy, and the third is made up of leisure-hour studies by the translator, G. P. Bergantini. Of the original de Thou poems the third (1587) edition is the best. All are very rare, especially Bergantini's translation. That scarce printing of this poem (Venice, 1735) is in the Maclay Collection.

TILANDER, GUNNAR. *Le livre de chasse du roy Modus [Method]*. small folio. pp. 24+204. 51

figs. in the text. Many miniatures from MS. Français 12399 de la Bibliothèque Nationale. Paris, 1931. .W.

The preceding is transcribed into modern French, with notes by Tilander. Part V, pp. 117-93, is devoted to falconry, with a good glossary of falconer's terms—altogether a valuable work on the subject. Roy Modus (King Method), like Royne Ratio (Queen Reason), is an unknown quantity in the treatise—neither of them ever existed as a personality. See Harting (pp. 61-65) on the disputed authorship. Also FERRIÈRES.

———. "Etude sur les traductions en vieux français du traité de fauconnerie de l'Empereur Frédéric II," *Zeitschrift für romanische Philologie*, XLVI, 211-290 (1926). .W.

This is a very desirable reference item for use in making a study of the *De Arte Venandi*.

TIMUR MIRZĀ QĀJĀR (PRINCE); (OR TAYMUR MIRZĀ). *Bāz-nāmā-i-Nāsuri*. Persian treatise on falconry and falcons. 8vo. pp. 126. 2 cuts in text. Lithographed in Bombay, A.D. 1900. .W.

Another edition, with many more cuts—several of patterns of hoods—also lithographed, Bombay, 1890, is also in the Wood Library.

A very important work by a falconer who flourished in the middle of the nineteenth century. The original gives a detailed account of falcons as well as of hunting-birds in general, and the writer quotes from a number of early authorities on falconry. Both the original and the lithographed copies are quite rare. See also PHILLOTT, D. C.

TIRABASCO, ANTONIO (d. 1773). *L'uccellagione libre tre de . . . Cittadino Veronese*. 4to. pp. 1+116. Verona, 1775.

This is the first edition of a poem, published two years after the poet's death by his widow, that sings the praises of fowling and includes much of falconry. The original manuscript is still preserved in the *Seminario dall'Abate Santo Fontano* at Verona. The work has passed through many editions and historical reviews (see Harting, p. 155). Of these only one, an octavo, published in Parma, by Gozzi in 1803, is in the Wood Library.

TITO, GIOVANNI SCANDIANESE. See SCANDIANESE, TITO GIOVANNI.

TOESCA, P. *Storia dell'arte Italiana*. Milano, 1927. pp. 1061-62.

A critique of the miniatures of the *De Arte Venandi*.

TROCCHI, DINO. *Falconeria*. 2 parts. 8vo. pp. 115. woodcuts; index. Milano, La Stampa Commerciale (1927). .W.

A useful little textbook; illustrations mediocre.

TUAN CH'ĒNG-SHIH (9th century A.D.). *Jou kuo pu*. Description of birds of prey, such as eagles, and the way to catch them. 18 x 11.9 cm. pp. 7. (In *T'angtai ts'ung shu*.) 1806. .G.

Copy of an interesting work on falconry; one of the earliest ever written in any language.

TUANO. See THUANUS.

TUNG SŪ-CHANG (7th century). *Kuang po wu chih*. 25.7 x 16.6 cm. 1761. .G.

Print of a very early encyclopedic work on zoology with an account of Chinese birds, including falcons and their uses for hunting.

TURBERVILLE, GEORGE (1540-1610). *The Booke of Faulconrie or Hawking; for the onely delight and pleasure of all Noblemen and Gentlemen. Collected out of the best aucthors as well Italians as Frenchmen, and some English practises with all concerning faulconrie . . . Nocet empta dolore voluptas*. (Christopher Barker.) small 4to. London, 1575.

This is the first edition of a work on the noble sport by a "Gentleman" and a poet. It is, as indicated by the title, something of a compilation but, in their turn, later writers borrowed from it. The author was a government official who lived in the days of Queen Elizabeth and was an intimate friend of the poet Spenser. There are several full-page pictures of falconry scenes. Very rare.

———. *The Booke of Falconrie . . . Hertofore published by George Turberville . . . and now newly revived, corrected and augmented with many new additions proper to these present times. . . .* (Thos. Purfoot.) London, 1611. small 4to. pp. 3+370. 2 fols. (Epilogue.) .W.

Bound with his *Noble art of venerie or hunting*. 1611. The bust of Queen Elizabeth on horseback, depicted in the first edition, has been replaced by the portrait of James I. This description is of the second edition; otherwise the two works—both very rare—are practically identical. The second part, on hunting-dogs (pp. 253), ends with musical notes, i.e., the different "measures of blowing" during the "venerie." A most quaint volume throughout.

TURNER, WM. (d. 1568). *Avium praecipuarum, quarum apud Plinium et Aristotelem mentio est*,

brevis et succincta historia ex optimis quibus que scriptoribus contexta, scholio illustrata et aucta. Adiectis nominibus Germanicis et Britannicis; Coloniae. Anno M.D. XLIII. 8vo. pp. [2]+ [155]. Cologne, 1544. .W.

This, the first (printed) systematic work on birds, breathes the modern spirit of research and is of considerable value for identifying the birds of the *De Arte Venandi*. Pp. xiv *et seq.* give a list of birds diagnosed and listed by Turner. It is one of the *rarisima* of ornithological literature. See also EVANS, A. H.

TU YA T'SI'UN. *Zoological Nomenclature*. 9 x 6 in. pp. 2635. Many colored and black-and-white illus. English-Chinese index; also separate Chinese index. Shanghai, 1927.

A complete dictionary, monumental in character, of zoological terms, including those about birds of prey; of extreme value to advanced students of falconry in the Far East.

TWICI, GUILLAUME. (*Also TWIXI and TWETY.*) *L'Art de Vènerie composé au 13^e Siècle ... en France*. 8vo. Paris (Pairault), 1883.

The author was Grand Huntsman to Edward II. There is an English translation of this manuscript (from the Sir T. Phillips of Cheltenham MS. Collection, No. 8336), with notes by H. Dryden, published by Thos. Barrett, Daventry, 1843. The monograph is the most ancient of French treatises on hunting—including some falconry. It was written about the middle of the fourteenth century. Thiébaud (p. 911) lists four items on Twici, one in English, three in French.

UDINE, HERCOLE (ERCOLE). *De la Psiche*. Poem. 8vo. 4 of 8 engravings of hunting scenes in this copy missing. 3d edition (1602?). The last canto deals with falconry. .W.

UHAGON, F. R. DE. *Libros de cetreria* [Falconry] (16th century). Not in British Museum, but in London Library, St. James Square.

UHRSPERG, CONRAD. *Leben Kaiser Fredericks II, Chronic*. pp. 305. Zullichan, 1792.
Not seen.

VALLI DA TODI, ANTONIO. *Il canto degli uccelli. Opera nova*. Two incomplete copies combined as one (nearly) complete. Very rare medieval ornithology, illus. ca. 56 fols. and pictures of birds. Roma, 1601. .W.

VALVASONE, ERASMO DI (1523-1593). *La Caccia: poema con gli argomenti a ciascun del Sig. Gio.*

Domenico degli Alessandri. small 8vo. Bergamo, 1591.

According to Harting (p. 147) this poem was very popular at the end of the sixteenth and beginning of the seventeenth century, passing through numerous editions with occasional variant in title. Bergamo, 1593, 1594, and 1603; Venice, 1602, 1611, 1612; Milan, 1808. There is a 1620 Venice print in the Maclay Collection. There are five cantos, the fifth dealing with falconry, the different kinds of hawks, how to catch and train them, and how to treat their various ailments.

———. *La caccia ... ricorretta et di molte stanze ampliata con le annotationi di Olimpio Marcucci*. In Venetia, per Fanco Bolzetta, 1602. 24mo. 4+167 fols. pl. .W.

VELSER, MARCUS. See FREDERICK II. First item.

VENTURI. *Storia dell'arte italiana*. Milano, 1903. .W.

One of the best descriptions (Vols. I and II) of the miniatures of the Vatican Codex of the *De Arte Venandi*.

VERDIZOTTI, GIO. MARIO. *Cento favole morali*. Venice, 1570.

Hawking plate on p. 250. Maclay Catalogue. Not seen.

VESEY, ERNEST. See LEWIS, ERNEST.

VIETINGHOFF-RIESCH, A. VON, AND PFEIFFER, M. A. *Falken über uns*. 4to. 32 pls., 72 figs. Berlin, 1937. .W.

An interesting and well-illustrated account of modern falconry with many observations based on a true falconer's experience.

VITZTHUM, G. *Die Pariser Miniaturmalerei des XIII^e Jahrhunderts*. Leipzig, 1907.

Excellent for reference to the illustrations of the Paris manuscript of the *De Arte Venandi*.

VOGELE, HANS-HEINRICH. *Die Falknerei. Eine ethnographische Darstellung*. small 4to. pp. 106. 99 illus., maps and tables; glossary. Neudamm, 1931. .W.

Bound with Fritz Engelmann's *Meine Lieblinge, die falken*. 1925. The best work on the ethnography of falconry and the distribution of that sport over the world in all ages; also maps, glossary, and many tables illustrating the whole subject.

VOLBACH, F. W. *Tafelbuch der Preusz. Kunstsammlungen*, 1932.

A very useful work on medieval art, as is also his *Elfenbildwerke*, Berlin, 1923.

- WALLER, RENZ. *Der wilde Falk ist mein Gesell; Beizjagderlebnisse und praktische Falknerei für deutsche Verhältnisse um das Jahr 1937*. Neudamm, J. Neumann, 1937. 8vo. pp. 403+[1]. illus.
- A brief account of falconry as seen by an accomplished artist, whose drawings from nature are well reproduced.
- WALTON, IZAAK (1593-1683). *The Compleat Angler; or the Contemplative Man's Recreations*. 12mo. London, 1653. .W., .O., .B.
- A short title of this famous treatise, whose second edition, 1655, contains remarks on falconry by "Anceps," a falconer, who furnishes a roster of long-winged and short-winged hawks used in England at that time. To the fifth and subsequent editions, revised by Walton, were added Cotton's remarks. The McGill Libraries have 18 editions, facsimiles, reprints, and originals of the *Angler*—a very small proportion of the whole, since the output to date is considerably over a hundred and fifty, vying in that respect with the equally popular *Natural History of Selborne*.
- WANG CH'I (16th century). *San ts'ai t'u hui*. 24.4 x 16 cm. A.D. 1609. .G.
- An illustrated encyclopedia, giving a description of Chinese animals, including hunting-birds.
- WANG YING-LIN (1223-1296). *Yü hai*. 27 x 17 cm. Published during the Ming Dynasty (1368-1644), about A.D. 1500.
- An encyclopedia of natural history dealing, *inter alia*, with Chinese bird life, including birds of prey and their uses in venery.
- WERTH, HERMANN. *Altfranzösische Jagdlehrbücher nebst Handschriftenbibliographie der abendländischen Jagdlitteratur überhaupt*. 4to. pp. 118. index. Halle a/S. 1889. .W.
- The title well describes the contents of this carefully prepared monograph, which should be read in the original. Part VI, page 33, is devoted to a brief account of the writings of Friedrich II. In like manner the (hunting) literature of Roy Dancus, Ptolemaeus, Daude de Pradas, Ghatrif, Moamyn, Albertus Magnus, Tardif, and many other writers on falconry is discussed.
- WETMORE, ALEXANDER (1886-). *The Migration of Birds*. 8vo. pp. 217. 7 figs. in text; table of contents; index. Harvard University Press, Cambridge, 1930. .W.
- The latest and best treatise on a difficult subject, that also deeply interested Frederick II. Dr. Wetmore gives his conclusions on p. 217.
- WEYWERCK, ADELICH. *Anderer Theil, Nemlich Falcknerey*, etc. Frankfurt, 1582.
- Very rare item. Maclay Collection. Not seen.
- WILLIAM THE FALCONER. *On Falconry*. .W.
- C. H. Haskins (*Romanic Review*, Vol. XIII, Jan.-Mar., 1922 [No. 1], pp. 20-22) tells us that the original manual of William (attached to the court of Roger II) was lost, but Albertus Magnus several times quotes from it. Without doubt this expert falconer and his treatise were well known to Frederick II.
- WILLUGHBY, FRANCIS (1635-1672). See RAY, JOHN.
- WOOD, CASEY A. (1856-). *An Introduction to the Study of Vertebrate Zoology*. small folio. pp. 19+643; colored front. Oxford University Press, London, 1931. .W.
- Apart from frequent references to Frederick II and his writings, most of the treatises quoted in the present translation are catalogued and annotated in this introduction.
- YAR MUHAMMAD KHAN SHAWKAT. *Sayd-gah-i-Shawkati* (or *Bāz nāma*). On falconry and birds. 4to. pp. 338. illus. lithographed. Rampur, 1884. In Hindustani. .W.
- Of considerable interest for students of Oriental ornithology and falconry. The illustrations include patterns of hoods as well as portraits of the hawks employed in Far Eastern sport. Ivanow notes that the work gives a good and accurate account of the subject. This is a very rare treatise as may be judged by the assertion of Harting that no treatise on falconry had been written in Hindustani. Several are listed in the present bibliography.
- YATRIE. Arabic treatise on falconry. Probably translated by order of Frederick II. See also DANIEL OF CREMONA.
- ZAMBRINI, FRANCESCO. *Trattatello di falconeria. Libro delle nature degli uccelli fatto per lo re Danchi testo antico toscano messo in luce da Francesco Zambrini*. 8vo. pp. 34+71. colored initials. 31 colored cuts in text. Bologna, 1874. .B.
- A fine reproduction of a Tuscan codex (A.D. 1414) on falconry and the care of birds in general. This remarkably well-made facsimile is rare. See also ROY DANCUS.



**Glossary of English and Latin Terms
and General Index**

COMBINED LATIN-ENGLISH AND ENGLISH-LATIN GLOSSARY

OF WORDS, TERMS, AND EXPRESSIONS PECULIAR TO ANCIENT, MEDIEVAL, AND MODERN FALCONRY

THE purpose of the following vocabulary is not to form a complete dictionary of Latin and English words and phrases peculiar to medieval falconry. It is, however, designed to furnish the meaning of the most common of these expressions in both languages, especially of those employed (in barbaric Latin) by the Imperial author in his *De Arte Venandi*.

A translation or definition of the more obscure or involved terms and expressions will be found also in the body of the translation, often as footnotes. The attempt to relay exactly some messages from Frederick himself has now and then seriously embarrassed the translators, who have encountered many difficulties therefrom; but they hope few egregious errors have been made. In this effort they have been greatly assisted by a study of Schneider's valuable *Index Vocabularum* and by J. H. Baxter and Charles Johnson's *Medieval Latin Word-List* (Oxford University Press, 1934).

As Haskins points out (*Studies in Medieval Culture*, p. 108), Frederick II complained that he could not himself find suitable Latin equivalents for all the technical (vernacular) terms used in falconry. This was due in part to the fact that the clergy, the literary class, who wrote classical Latin, were debarred from using most forms of sport,

while the knights—the sporting and generally illiterate class—were rarely well versed in that tongue but spoke and hunted in the vernacular.

In the accompanying list the *falcon* is generally assumed to be the female bird, and as such is referred to as “she” or “her.” Some writers, in referring to either or both sexes, use the pronoun “it.” The word *hawk* is used indifferently to mean either the long-winged species (falcon) or the short-winged bird commonly known as a “hawk,” and to include either or both sexes.

The translators have been unable to see the necessity of following the usual custom of compiling in separate columns, or pages, words or meanings peculiar to falconry in several languages. On the contrary, they discern a saving of time as well as other advantages for this treatise in a single inclusive and continuous glossary, especially if the list comprises all the useful synonyms and cross references in Latin and English—the languages with which they are for the moment chiefly concerned.

A few of the terms herein defined have been obsolete during one or more centuries; others represent objects or ideas that have had only a transitory or purely local vogue; still others are of doubtful meaning or have been differently defined at various times and places by the authorities. These examples are,

however, rare; the expressions used by falconers the world over have been remarkably constant throughout the ages and there have been but slight variations in their interpretation since the noble art was first introduced. It will also be noticed that some English ex-

Abbecatio. *n.* L. Titbit, morsel.
Abbeccare. **Abectare.** *n.* L. Bechin (*q.v.*)
 Cf. French *becqueter*.
Abluere. *v.* L. To bathe. *See also* BALNEARE.
Acari. *n.* L. Mites (*q.v.*).
Accendere. *v.* L. To mount in air; to soar.
Acceptor. *n.* L. A hawk.
Accipiter. *n.* L. A hawk.
Accipiter nisus. *n.* L. Sparrow hawk (*q.v.*)
Accipitrarius. *n.* L. A falconer. *See also* FALCONARIUS *and* AUCUPIUM.
Acus. *n.* L. *See* IMPING-NEEDLE.
Advolare. *v.* L. To train (the falcon).
Affamatae pennae. L. Feathers showing signs of starvation or improper feeding — "hunger traces."
Ague. Malaria, fever attacking hawks.
Aiery. **Ayre.** *n.* Old English (Shakespearean) spelling of eyrie (*q.v.*).
Air. *See* KEEPING THE AIR.
Alaudarius. *n.* L. The hobby, favorite small falcon (*Falco subbuteo*) for hunting larks and similar quarry.
Albanus. *n.* L. Hen-harrier. Italian *albanella*.
Alimenta. *n.* L. Prepared food for hawks in training, hawk's food; *see also* CARO.
Allectare. *v.* L. (*a*) To lure (*q.v.*). *See also* LOGORUM EXHIBERE AUT OSTENDERE; REVOCARE. (*b*) In training to call off the hawk from an assistant by means of the lure.
Alphanet. The Tunisian lanner.
Altanus. *n.* L. Peregrine falcon. Cf. Portuguese *altaneiro* or "high-flyer."
Altivolare. *v.* L. To soar (*q.v.*); to ascend in spirals (*spiraliter aethera scandere*); to ring up.

pressions have, for good reason, no Latin equivalents; and the Emperor himself found difficulty in translating quite a few jargonic words and phrases of his falconers into even medieval Latin. Examples of such expressions will be found in the following list:

Antennaire. *n.* F. A hawk completely moulted "the year before" her second year.
Aptha. *n.* L. The thrush.
Apostume. *n.* Severe purulent infection in the head; an abscess.
Aquila. *n.* L. An eagle.
Ardea. *n.* L. Common heron (*q.v.*).
Ardeola. *n.* L. Smaller heron species. *See* HERON.
Area. *n.* L. *Also* NIDUS. Hawk's nest. *See* EYRIE.
Arm (of a hawk). *n.* Leg from the foot to the thigh.
Arripere. *v.* L. To bind (*q.v.*) or clutch. *See also* PREHENDERE.
Ars accipitraria. *n.* L. The actual practice of hawking in the field, as less noble than the *Ars falconaria* (*q.v.*).
Ars falconaria. *n.* L. The truly noble art of falconry; as opposed to the less noble *Ars accipitraria* (*q.v.*).
Asportare. *v.* L. To carry, to fly away with the quarry.
Assecurare. *v.* L. To secure quiet (usually by darkness or semiblindness) for falcons who would otherwise be disturbed by strange sights and noises.
Assuetus loyro. *v.* L. Trained to the lure.
Astragus. *n.* L. (Blome.) A falconer using short-winged hawks; in a lower category than those nobles who employed long-winged birds. *See* OSTRINGER.
Astringer. *n.* One who owns and flies short-winged hawks.
Astur. **Austur.** *n.* L. A hawk; a goshawk.
Aucupium (from aucupare). *n.* L. A falconer. *See also* FALCONARIUS.

- Austringer.** *See* OSTRINGER.
- Axilla.** *n.* L. *See* SUBAXILLARIA OSSA.
- Ayronerius.** *n.* L. Heron hawk; falcon (especially the saker) used to hunt herons; a heroner.
- Bagged quarry.** Live pigeons or other birds kept as prey for training hawks.
- Balneare.** *v.* L. To bathe. *See also* ABLUERE.
- Barbary falcon.** *Falco barbarus*; small species; a favorite with hunters; also called the *tartaret*.
- Bare-faced.** *adj.* Unhooded.
- Bate.** *v.* To spring from her perch or the fist in an attempt to fly away. L., *diverberare*.
- Bawrel.** *n.* Name applied by Blome to (probably) the Iceland falcon, *Falco islandus*.
- Bawret.** *n.* Male of the bawrel (according to Blome) (*q.v.*).
- Beam feathers.** The long pinions of the wings; the primaries.
- Bechin.** *n.* Titbit, morsel, savory mouthful, cold snack.
- Bell.** *n.* Hawk's bell. *See also* CAMPANELLA, NOLA.
- Berkute.** *n.* One of the eagles used in Asia for hunting, perhaps *Aquila nobilis*.
- Bewits.** *n.* The leather straps attached to the hawk's feet to carry the bells and to hold the bird on the fist.
- Bibere aquam.** *v.* L. To drink, bathe in, or otherwise make use of water.
- Bind.** *v.* To seize and fasten on the quarry in the air.
- Birdlime.** *See* LIME.
- Blain.** *n.* Watery vesicle forming on the second joint of the wing.
- Block.** *n.* A pyramid, truncated cone, or cylinder of wood or stone, commonly encircled by a ring or other device and provided with an arrangement for attaching the leash, on which the hawk is placed outdoors to weather, feed, and bathe.
- Block.** *v.* To go to perch; said of the falcon which, instead of waiting on over the spot where the quarry has taken refuge, perches on a tree or other place of advantage near by.
- Blue hawk.** *n.* Young peregrine, before the red phase.
- Bob.** *v.* To shirk the hood.
- Bolt.** *v.* To fly to attack; said of short-winged hawks which fly straight at the quarry from the fist.
- Bonelli's eagle.** *Aquila bonellii*. The most useful of the European eagles trained for the chase, mostly of small quadrupeds.
- Bowet.** *n.* A brancher (*q.v.*), i.e., one which roosts on the boughs near the nest.
- Bowiser.** *n.* A brancher (*q.v.*).
- Bow net.** *n.* Device for catching hawks; a net stretched over a metal half-hoop and worked by a cord.
- Bow perch.** A perch in the shape of a half-circle, the ends sunk in the ground.
- Bowse.** *v.* To drink (unduly); said of a hawk.
- Bracalae.** *n.* L. The under-tail coverts of a bird.
- Brace.** *v.* To tighten the hood.
- Brail.** *Brayle.* *n.* A leather thong to bind one or both wings. *See* CORRIGIOLA.
- Brancher.** *n.* A fledgling that is able to hop from branch to branch near the nest. *Also* BOWET, BOWISER.
- Brayle.** *Brail.* *n.* Leather thong with a slit in it to put about and confine the hawk's wing.
- Bubo.** *n.* L. Eagle owl.
- Bursa.** *n.* L. Hawking bag or purse. *See also* CARNERIA.
- Cadge.** *n.* The low frame (rectangular perch) with short legs on which the cadger (*q.v.*) carries hawks (generally hooded) to the field.
- Cadger.** *n.* The carrier of the cadge (*q.v.*).
- Call off.** *v.* To lure a hawk from an assistant while training her.
- Camera.** *n.* L. Hawk house, mews (*q.v.*). *See also* MUTA, MUTATORIUM.
- Campanella.** *Campanellum.* *n.* L. Hawk's bell, *pedibus alligata* (attached to the feet). *See* BELL, NOLA.
- Canceler.** *v.* To swerve abruptly; said of the hawk when, during a stoop, she makes several abrupt turns.

- Cancellaring.** *v.* Stooping (*q.v.*) and swerving in pursuit of the quarry.
- Capellum deponere.** *v. L.* To unhood; to remove the hawk's hood.
- Capellum induere.** *v. L.* To hood the falcon, i.e., to place the hawk's hood on her head.
- Capellus.** *n. L.* See also CUCULLUS; CAPELLUM (Schneider). The hood (*q.v.*); leathern cap or blinders used in taming birds of prey, also for constant wear if needed. The hood was introduced into Europe by Frederick II, who adopted it from the Arabs of Syria. See also RUFTER HOOD.
- [Se]Capere.** *v. L.* To crab (*q.v.*).
- Capere corata.** *v. L.* To stoop in pursuit of the quarry. See also CAPERE PRAEDAM.
- Capere praedam.** *v. L.* To stoop (*q.v.*). See also CAPERE CORATA.
- Carneria.** *n. L.* Hawking bag or purse. See also BURSA.
- Caro.** *n. L.* Hawk's meat; prepared food for hawks in training. See also ALIMENTA.
- Carry.** *v.* To fly away with the quarry or articles of food; to lift (*q.v.*).
- Cast.** *v.* To vomit up a casting (*q.v.*). To brail (*q.v.*), or hold the hawk for coping or hooding.
- Casting.** *n.* A laxative dose of fur, feathers, wool, etc., given the hawk with her food to evacuate her pannel (*q.v.*). This dose is afterward vomited up as an oblong or ovoid pellet enclosing any indigestible food lying in the gut; small pebbles, which the bird swallows readily, have much the same effect.
- Cast of hawks.** A pair of hawks.
- Cast off.** *v.* To direct or impel the hawk from the fist to chase the quarry.
- Castrel.** *n.* Kestrel (*q.v.*).
- Catarrh.** *n.* Simple infection or cold in the head, common in hawks.
- Cauda.** *n. L.* Tail or train of the bird.
- Cawking time.** Copulation, treading, or coupling period.
- Cera.** *n. L.* The cere (*q.v.*).
- Cere.** *n.* The smooth, waxlike integument (*cera*) at the base of the upper mandibles.
- Check.** *v.* To forsake her legitimate quarry and fly after other prey that crosses the path of the hunting falcon.
- Chirotheca.** *n. L.* Glove; falconer's glove (*q.v.*) or gauntlet. Also CIROTHECA; MANICA CORIACEA.
- Cilia in palpebris avium.** *L.* Often used to designate the eyebrow.
- Ciliare.** *v. L.* To blind by seeling; see SEEL.
- Ciliatio.** *n. L.* Blinding by means of ciliation; see SEEL.
- Circellae.** *n. L.* Variety of ducks.
- Circumducere loyrum.** *v. L.* To swing the lure.
- Circumire in pertica aut sedile.** *L.* To settle the falcon on her perch.
- Circumvolare.** *v. L.* To wait on. Bologna MS., Book VI, fol. 128: *Circumvolare vero dicimus quoniam in circuita volat super falconiarium.*
- Cirotheca.** *n. L.* See CHIROTHECA.
- Clamorosus.** *n. L.* An eyas (*q.v.*) or nestling (screamer). *Clamorosi nidasi*, screamers or screaming eyases.
- Clap.** *n.* The lower mandible.
- Claws.** *n.* Toes of a short-winged hawk.
- Clean-moulted.** *adj.* Having a complete, fresh set of feathers.
- Clitch.** *v.* To adhere, to thicken.
- Clutch.** *v.* To seize the quarry by the legs.
- Coat.** *n.* Period plumage; i.e., a hawk of the *first coat* is one that has established her first array of feathers, a hawk of the *second coat* one after her second moult, and so on.
- Coll.** *v.* To clasp or embrace.
- Come to.** *v.* To obey the falconer.
- Concambium.** *n.* See EXCHANGE.
- Concoquere cibum.** *v. L.* To devour greedily or "wolf" food.
- Consentire.** *v. L.* To join; said when two falcons co-operate in flight and on the quarry.
- Coping.** *v.* Paring or dulling the sharp points of the hawk's beak or talons; removal of undue growth of the same. The wild bird accomplishes it by rubbing them on a rock.
- Coping iron.** *n.* Pincers, knife, or other instrument for paring the talons or beak.

- Corales pennae.** *n.* L. Flight feathers (tertiaries).
- Corata.** *n.* L. The quarry (*q.v.*) or prey. *See also* PRAEDA.
- Cornelli.** *See* CORNS.
- Corns.** *n.* Horn-like growths on the feet of birds of prey caused by roosting on hard or unpadded perches.
- Corrigia.** *n.* L. A bewit (*q.v.*). *See also* CORRIGIOLA.
- Corrigiola.** *n.* L. A bewit (*q.v.*). *See also* CORRIGIA; BRAIL.
- Corrosae pennae.** *n.* L. Discolored feathers. *See* Book II, chapter xxx.
- Costa pennarum.** *n.* L. Shaft or rachis of the feather.
- Coward.** *n.* A weak, derelict falcon that has lost her courage. *See* REPULSATUS.
- Cowering. Cowering.** *adj.* Said of young birds shaking their wings or quivering, as evidence of obedience to the falconer or to the parent birds.
- Cowl.** *n.* *See* HOOD.
- Crab.** *v.* To fight (said of two falcons).
- Crabbing.** *v.* Clawing or fighting. Said of a hawk when one of a cast fights with or seizes the other instead of the prey.
- Cramp.** *n.* Fatal form of tetanus affecting most muscles of the body.
- Cray. Craye.** *n.* Obstruction of the tewel or lower bowel.
- Creance.** *n.* Fine cord or line attachable to the hawk's leash when she is first lured.
- Credentia.** *n.* L. A creance (*q.v.*). *See also* FILERIA.
- Crivets.** *n.* The small, dark, hair-like feathers about the hawk's eyes.
- Croaks. Kecks.** Disease of the bronchia; from the sound made by the invalid on exertion. *See* PIN.
- Crop.** *n.* Upper portion of the gullet where the food first lodges after swallowing.
- Crossing flight.** *n.* The passage of a bird between the falcon and her quarry.
- Crutch.** *n.* A cross-like pole, capable of being fitted to the saddle, for carrying on horseback heavy hunting birds, generally eagles.
- Cucullus.** *n.* L. Hawk's hood. *See* CAPELLUS.
- Cultellus.** *n.* L. Primary flight feather (*q.v.*).
- Curare.** *v.* L. To instruct (the falcon).
- Curatio.** *n.* L. Training or education of a hawk.
- Deck feathers.** *n.* The two central feathers of the tail.
- Decoy hawk.** *n.* One used to attract and recover a lost bird.
- Deplume.** *v.* To strip the feathers off the quarry, as is done by the falcon.
- Deverberare.** *v.* L. To bate; *see also* BATE, DIVERBERATIO.
- Digiti interioris unguis.** L. The bird's grasping talons (*quo cibus laceratur et inciditur*).
- Disclose.** *v.* To appear (as in the embryo) through the shell for the first time.
- Disclosed.** *adj.* The first appearance of the bird within the shell.
- Diverberare. Deverberare.** *v.* L. To bate.
- Diverberatio.** *n.* L. Bating. *See* BATE.
- Domus.** *n.* L. Mews; falcon's indoor residence.
- Dorsum.** *n.* L. The back of the bird; *see* Book II, chap. xxiv, p. 122: *Dorsum est spatium inter utramque spatulam seu humerum*.
- Draw (from the mew).** *v.* To take the falcon out after she has moulted.
- Drawer.** *n.* Old English synonym for lure (*q.v.*).
- Droppings.** *n.* The excrement of the falcon vented as drops instead of being ejected straight backward.
- Duck hawk.** The American race of the peregrine (*Falco peregrinus anatum*).
- Dumae seu lanulae.** *n.* L. Down or wool feathers.
- Educare.** *v.* L. To educate or train.
- Egerere.** *v.* L. To mute.
- Egestio.** *n.* L. Mutes.
- Emittere (de manu).** *v.* L. To throw off, or slip, the falcon.
- Empennes.** *n.* L. *Ala spuria*, or false wing.

- Empiones.** **Empiones.** *n.* L. Pinions; generally the smallest of these feathers.
- Endew.** **Endue.** *v.* To digest food normally.
- Enew.** **Inew.** *v.* To drive the quarry to cover. *See* PUT IN.
- Engout.** *v.* To show black spots on the feathers.
- Ennue.** *v.* To enew. To put into cover. To make a point.
- Ensayme.** **Enseam.** *v.* To purge.
- Enter a hawk.** *v.* (L., *intrare.*) To fly for her first kill in training.
- Esauriare.** *v.* L. To air, ventilate, or cool off; to fly high in circles, with extended wings and tail. *See also* EXAUREARE.
- Esparvarius.** *n.* L. The sparrow hawk (*q.v.*).
- Exaureare.** *v.* L. To cool off. *See* ESAURiare.
- Exchange.** **Concambium.** *n.* The act of checking; said when the falcon deserts her proper quarry to chase another bird.
- Excrement.** **Excrementa.** *n.* L. Mutes (*q.v.*), or avian excrement. *See also* STERCORA.
- Excutare.** *v.* L. To rouse, as when the falcon raises and shakes herself.
- Expectare.** *v.* L. To wait on (*q.v.*).
- Expurgare.** *v.* L. To purge; to cause to lose superfluous fat.
- Eyas.** **Eyass.** **Eyess.** Hawk taken from the nest.
- Eyrie.** **Eyre.** **Eyry.** *n.* Hawk's nesting place; falcon's nest. *See also* AIERY, AYRE.
- Falco ad ardeam.** L. Heron hawk; one, especially the gerfalcon, trained to capture herons.
- Falco doctus.** *n.* L. Make-falcon (*q.v.*); trained falcon used to assist in the training of other hawks or falcons.
- Falco gentilis.** *n.* L. A male falcon; also noble falcon.
- Falco mutatus.** *n.* L. A haggard (*q.v.*).
- Falcon.** *n.* In many English treatises referring to the female peregrine in particular but applied as a rule to the female of all long-winged hawks.
- Falcon gentle.** *n.* The male of the species, generally the tercel. L., *gentilis.*
- Falconarius.** *n.* L. A falconer.
- Falconer's glove.** *n.* L. *Manica coriacea.* A gauntlet of heavy leather to protect (from talons and beak) the hand and wrist carrying the falcon.
- Falcones capti de passagio.** L. Falcons captured in migration.
- Falconet.** *n.* A species of small falcon used in hunting. Among them are Feilden's falcon, the black-legged falconet (*Hierax fringillarius*), the white-legged falconet (*H. melano-leucus*), and the red-legged species.
- Falconum portator.** *n.* L. Cadger or cadge-bearer.
- Falco sacer.** *n.* L. The saker (*q.v.*).
- Falco saurus.** *n.* L. *Also* sores. Sorehawk; a hawk in her first year. *See* RED HAWK.
- Fall at mark.** *v.* To alight on the ground and there await the arrival of the owner.
- Feake.** *v.* To wipe the beak on the perch after feeding.
- Fellenden.** *n.* Intestinal worms.
- Femur.** *n.* L. Thighbone.
- Ferire.** *v.* L. To clutch with the talons.
- Fictitius.** *n.* L. A shirker, a pretender (*q.v.*).
- Filanders.** *n.* *Filaria* (*q.v.*).
- Filaria.** *n.* L. Intestinal parasites. *Also* FILANDERS.
- Fileria.** *n.* L. A creance (*q.v.*). *See also* CREDENTIA.
- Filo ligare alas.** *v.* L. To brail or apply a binder (*q.v.*); *also* CORRIGIOLA (*q.v.*).
- Fimum reddere.** *v.* L. To mute or excrete dung. *See* MUTES.
- Flagellare alis.** *v.* L. To thrash or flap the wings; *see* Book II, chapter lii, p. 169.
- Flags.** *n.* Secondaries, wing feathers; also plumage next the principal wing feathers.
- Flight feathers.** *n.* The pinions of the wings.
- Flush.** *v.* To raise the quarry. L., *levare.*
- Fly at hack.** *v.* To be in that state of liberty in which hawks are kept during their early period of taming. *Volare huc et illuc.*

- Fly on head.** *v.* To miss the stroke at the quarry; then to check and attack the next prey.
- Fly to mark.** *v.* Said of a hawk who, having marked the locality in which the quarry has taken shelter, waits on there for the falconer to put up the prey.
- Foot.** *v.* To catch and hold the prey with the talons.
- Footer.** *n.* A hawk that expertly catches and holds the quarry.
- Foras portare.** *v.* L. To weather or accustom the captured hawk to an outdoor life.
- Formale.** *n.* The female hawk.
- Formica.** *n.* L. *Acarus*. An insect infesting the nasal cavities. See MITES.
- Fragelius.** *n.* L. A kind of falcon.
- Franquillini.** *n.* L. Francolins.
- Frogellus.** *n.* L. Apatha. Thrush.
- Frounce.** *n.* Canker or sore in the throat and mouth.
- Fugitivus.** *n.* L. A synonym for Peregrinus, the important passage hawk or pilgrim (*q.v.*).
- Full-summed.** *adj.* Said of a hawk that has all her fresh feathers after a moult.
- Gaius. Gaia.** *n.* L. Male and female woodpecker.
- Galbanum.** *n.* L. Gum resin from *Ferula galbaniflua*, much prized both as a local and an internal remedy in avian diseases.
- Ganta.** *n.* L. A goose.
- Garamantides aves.** *n.* L. Guinea fowl.
- Gate.** *n.* Elevation of the soaring hawk, whence to stoop at her prey.
- Gentiles.** L. See GENTLE FALCONS.
- Gentle falcons.** *n.* Male birds. *Gentiles*.
- Gerfalcon. Jerfalcon. Gyrfalcon.** *n.* Any of the large, white, arctic falcons found chiefly in Scandinavia; much valued as hunters by falconers, particularly those of the nobility.
- Get in.** *v.* To reach the hawk as soon as she has captured the prey.
- Girofalco. Gyrfalco.** *n.* L. Any of the large northern falcons.
- Gleam.** *n.* Material thrown up by the hawk after a casting gorge.
- Glove.** See FALCONER'S GLOVE.
- Glut.** *n.* The slimy material expelled from the lower intestine.
- Gorge.** *v.* To eat to repletion. *n.* The crop or craw.
- Gorgia.** *n.* L. Crop or gorge (*q.v.*); also *Gula* and *Ingluvies*.
- Gruerius.** *n.* L. Crane hawk; falcon expert in hunting the crane; usually the gerfalcon.
- Gurgiping.** *adj.* Stuffed to repletion; choking from an unduly large mouthful.
- Gyrare volando.** *v.* L. To fly (in rings of flight) through the upper air.
- Gyrfalco.** *n.* L. Girofalco (*q.v.*).
- Gyrfalcon.** *n.* Gerfalcon (*q.v.*).
- Hack.** *n.* Place, usually out of doors, where the hawk (usually young) is fed and is allowed liberty.
- Hack.** *v.* To fly at hack (*q.v.*); also (*n.*) the liberty, allowed young hawks before their regular training is begun, coming daily and regularly to the hack-board to be fed. *Volare huc et illuc*.
- Hack-bells.** *n.* Large and heavy bells attached to hawks to prevent them from fending for themselves while they are flying free, i.e., at hack.
- Hack-board.** *n.* The table or board on which the hawk's meat is cut up (hacked) and fed to her.
- Hack-hawk.** *n.* One that is fed, tamed, and trained at hack. A tackler (*q.v.*).
- Hackle.** *n.* Ornamental feathers of the bird's head.
- Haggard.** *n.* A wild peregrine hawk captured after it has moulted and is in adult plumage. Also *Falco mutatus semel*. A full-grown bird taken after Lent.
- Halsband.** *n.* (German.) An Oriental device consisting of a collar of soft silk placed about the neck of a sparrow hawk and held in the falconer's hand to steady her when she is cast off.
- Hand.** *n.* (Of a hawk.) The bird's foot.
- Hang on.** *v.* Same as "wait on" (*q.v.*).
- Havock.** *v.* To call or cry out.

- Hawk house.** *n.* Mews. Building in which hawks are kept or where they are placed to moult. L., *Camera, Muta, Mutatorium.*
- Hawk-of-the-fist.** *n.* (L., *Pugilarius.*) A short-winged bird.
- Hawk of the lure.** *n.* (L., *Loraria* or *Pinnaria.*) A falcon. One of the long-winged hawks.
- Hawk's meat.** *n.* Prepared food for hawks in training. L., *Caro, Alimenta.*
- Hawk-van.** *n.* A large box or frame on wheels, for the transport of hunting birds on a journey or in the field.
- Head (toward).** *v.* To fly in a certain direction. L., *vadare.*
- Heron.** *n.* Favorite game for falconers. Several species were hunted with the larger falcons, especially with the gerfalcon. L., *Ardea, Ardeola, Ayrones.*
- Heron hawk.** *n.* A hunting bird, especially the gerfalcon, trained to catch herons. L., *Falco ad ardeam.*
- Heronshaw.** *n.* Old English name for the heron (*q.v.*) (probably from French *heronceau*). L., *Ardea, Ardeola.*
- Hey. Heye.** *adj.* Old English for "in fine condition."
- "Hey, gar, gar!"** English falconer's cry, to encourage the hawk when in pursuit of her quarry.
- Hobby.** *n.* Small falcon, *Falco subbuteo*, much used for hunting larks—hence the Latin falconry synonym, *Alaudarius* (*q.v.*)—and other small birds. It is of most value in summer time; in autumn this hawk is likely, even when fully reclaimed, to migrate with the wild birds.
- Hood. Cowl. Blinder.** *n.* Leather head-covering for blinding the hawk, first introduced from the Orient into Europe by Frederick II.
- Hood.** *v.* To put the hawk's hood on her head. L., *Capellum induere.*
- "Hoo-ha-ha."** One of the cries of the English falconer to encourage the hawk, especially when first unhooded, to pursue the quarry.
- Hood off.** *v.* To pull off the head cover before slipping the falcon at her quarry.
- Hood-shy.** *adj.* Said of a hawk that dislikes the hood, because of having been mishandled when the hood was first put on.
- "Howit! Howit!"** A cry set up by some English falconers to encourage the hawk (waiting on) when the prey is routed from its hiding place.
- Huanus.** *n.* L. Uhu. Screech owl. French Chat-huant.
- Humeri os.** *n.* L. The upper arm bone, the humerus.
- Hunger traces.** *See* AFFAMATAE PENNAE.
- Imp.** *v.* To repair by substituting a metal shaft or needle and part of another feather for a broken pinion.
- Imping-needle.** *n.* (L., *Acus.*) Metal shaft introduced within the quill to strengthen and repair a broken pinion.
- Imponere.** *v.* L. To restore, by the aid of the imping needle (*q.v.*), a hawk's broken feathers. To imp.
- Impulsorium.** *n.* L. The heel of the wing. *See* JUNCTURAE ALARUM MEDIAE.
- Induere.** *v.* L. To endew (*q.v.*).
- Inew.** *See* ENEW.
- Inke.** *n.* Neck of the quarry.
- Instituere.** *v.* L. To train (*q.v.*) or educate.
- Intermewed.** *adj.* Said of the bird in the period between the falcon's first change of coloration and the white phase; dating usually from the time she begins to fend for herself until after her first moult, when she is in full feather. *See also* INTERMEWING.
- Intermewer.** *n.* A hawk in the second year of life; one that has mewed most of her feathers.
- Intermewing.** *n.* The change in plumage coloration until the final white phase.
- Intrare.** *v.* L. To enter (*q.v.*) a hawk.
- Inwards.** *adj.* Fond of the lure.
- Iridescence.** *n.* Gloss of the feathers, especially of the wings. *Pilositas pennarum et plumarum utriusque costae.*
- Jack.** *n.* The male hawk.
- Jack castrel.** *n.* Male of the castrel or kestrel.
- Jack hobby.** *n.* Male of the hobby.
- Jack merlin.** *n.* Male of the merlin.

- Jactare.** *v.* L. To cast off (*q.v.*).
- Jactare loyrum.** *v.* L. To throw or cast the lure.
- Jactus.** *n.* L. A jess. *See* JESSES.
- Jerfalcon.** *n.* Gerfalcon (*q.v.*).
- Jerkin.** *n.* The male of the gerfalcon.
- Jesses.** *n.* Narrow straps of leather attached to a hawk's legs, by which she is held. When on the fist these leather strips are held between the fingers. *L., Jacti; jacti sunt laquei de corio facti, imponendi pedibus falconum.*
- Join.** *v.* To become a co-pursuer; said of one hawk flying up and taking part with her companion in pursuit of the quarry.
- Jokin.** **Jokith.** *adj.* Ancient word for "asleep."
- Jouk.** *v.* To sleep.
- Juke.** *n.* Neck from the head to the body of the bird.
- Jump to the fist.** *v.* To spring or fly from the ground to the hand. The falcon is trained to do this generally by offering her bechins.
- Juncturae.** *Juncturae alarum mediae, seu impulsorium.* *L.* The heel of the wing. *See* Book II, chapter xix, p. 120.
- Kecks.** *See* CROAKS.
- Keeping the air.** Said of the quarry when it outflies the hunting bird and escapes.
- Kestrel.** *n.* Small, quite common, European falcon (*Cerchneis tinnunculus*), the sparrow hawk in America—about 12 inches long. *L., Tinnunculus. See also* CASTREL.
- Kite.** **Milan.** *n.* Medium-sized hawk, *Milvus ictinus*, with forked tail. Mixed feeder, on small reptiles, insects, and offal. Other species include *Milvus regalis*. Not used in falconry.
- Lagopus aurita.** *n.* *L.* Short-eared owl.
- Lanarius.** **Lanarius.** *n.* *L.* The lanner (*q.v.*).
- Lanner.** *n.* (*L., Lanarius; Falco lanarius.*) This bird was formerly much used in sport, and is fully described in the *De Arte Venandi*. In America, the prairie falcon.
- Lanneret.** *n.* Male of the lanner (*q.v.*).
- Lantiner.** *n.* A passage hawk caught late in the winter.
- Lanulae.** *n.* *L.* *See* DUMAE.
- Laxare ventre.** *v.* *L.* To purge; to evacuate the bowels.
- Laynes.** *See* LINES.
- Leach.** *n.* Leash.
- Lean.** *v.* To hold on to one.
- Leash.** **Leach.** *n.* (*L., Longa.*) A narrow leather thong attached to the jesses and perch; it may be wrapped around the hand to hold fast a captive bird. A "short leash" was once used for a goshawk, but not by the Emperor Frederick. *See* Harting, p. 190.
- Lenten hawk.** *n.* A passage hawk, arrived or caught at the Lenten season, about the period of her first moult. A Lentiner.
- Lentiner.** *n.* A Lenten hawk (*q.v.*).
- Lesser falcon.** *n.* (*L., Falco minor.*) A species resembling the Barbary falcon (*q.v.*) and, like it, found in Africa.
- Levare.** *v.* *L.* To flush (or raise) the quarry.
- Lewnes.** *n.* *See* LINES.
- Lift.** *v.* A synonym of "carry"; said of a hawk that flies off with a captured bird or quarry.
- Lime.** *n.* Birdlime. An extremely adhesive, viscid excretion of the holly (*Ilex aquifolium*), mistletoe, breadfruit, and other shrubs, so called because twigs smeared with it were and still are used to capture small birds.
- Lines.** **Laynes.** **Lunes.** **Lewnes.** *n.* Old English terms loosely applied to the (modern) leash, sometimes to the creance (*q.v.*).
- Live lure.** *n.* Generally a pigeon or other small bird offered alive to attract the falcon.
- Logorum.** *n.* *L.* A lure.
- Logorum exhibere aut ostendere.** *v.* *L.* To lure. *See also* ALLECTARE; REVOCARE.
- Longa.** *n.* *L.* The (long) leash (*q.v.*).
- Loni.** **Lozzi.** *n.* *L.* Wild beasts from Bohemia, of doubtful identity.
- Lorare.** *v.* *L.* To lure.
- Loraria.** *n.* *L.* Hawk of the lure (*q.v.*). *See also* PINNARIA.
- Lorarium.** *n.* *L.* Lure (*q.v.*) or drawer (*q.v.*).
- Lorum.** **Loyrum.** *n.* *L.* Lure (*q.v.*).

- Lugger.** *n.* An Indian name for the saker (*q.v.*). *Falco jugger*, a similar hawk, is used by Oriental falconers.
- Lumbrici falconum.** *n.* *L. Filaria* (*q.v.*).
- Lunes.** *n.* See **LINES**.
- Lure.** *n.* A weighted, leather device to which are attached a couple of pigeon or other wings. Garnished with additional feathers and meat, it serves, when swung about the falconer's head, to attract the free-flying hawk and to lure her back to his fist. See also **DRAWER**. *L., Logorum, Lorarium, Lorum.*
- Lure.** *v.* To attract the hawk by means of the lure (*q.v.*). *L., Allectare; Revocare; Logorum exhibere (ostendere).*
- Made.** *v.* Successfully trained; i.e., "made" to the lure or to the hood; said of a hawk.
- Mail.** *v.* To envelop the hawk in a bandage or sock (mail) to quiet her when first caught, or during imping, coping, etc. See also **SOCK**.
- Mails.** *n.* Chest feathers.
- Maime. Mammo.** *n.* *L.* A variety of monkey.
- Make.** *v.* To train; see **MADE**.
- Make-falcon. Make-hawk.** *n.* An old, experienced bird, flown with a young hawk to assist in the latter's training. A make-falcon; *falco doctus*, or *jam instructus*. See also **QUARRY HAWK**.
- Make in. Making in.** *v.* Carefully and slowly to approach the hawk who is holding her quarry on the ground.
- Make out.** *v.* To fly at check. See **CHECK**.
- Make to.** *v.* To train to or for a purpose.
- Making its point.** *v.* When the hawk forces the prey to cover (in hedge, bush, deep grass, etc.).
- Maleolum. Malleolum.** *n.* *L.* A sock (*q.v.*), or mail (*q.v.*).
- Maluitti.** *n.* *L.* Turtledoves.
- Man.** *v.* To tame or get the falcon accustomed to the presence of human beings.
- Manica coriacea.** *n.* *L.* Falconer's glove (*q.v.*).
- Mansuefacere.** *v.* *L.* To reclaim; to man, gentle, or tame a wild hawk: *Mansuefacere falconem ad standum super pugno*. See **Book II**, chapter xlix, p. 157.
- Mantle.** *v.* To stretch one wing after another, then the legs, and then the other members; said of a hawk.
- Manus.** *n.* *L.* The fist (hand). See also **PUGNUS**.
- Margo plumarum discolor.** *L.* Tints of a bird's plumage.
- Mar-hawk.** *n.* One who spoils a bird through ignorance, stupidity, or mishandling.
- Mark.** *v.* To wait, until retrieved, after having struck down the game; to soar above the quarry. See **FLY TO MARK**.
- Mary marrow.** *n.* (Obs.) An avian remedy, or an excipient for the same.
- Megrim.** *n.* Hawk's palsy; a disease accompanied by continuous shaking of the bird's head.
- Merle.** *n.* *L.* Name applied by Albertus Magnus to the merlin (*q.v.*).
- Merlin.** *n.* *Falco aesalon*. Pre-eminently the ladies' hawk. Small European species; in America, the pigeon hawk. *L., Smerilio.*
- Meta altitudinis.** *n.* *L.* Pitch; altitude reached by the falcon in soaring.
- Mew. Mews.** *n.* The house in which hawks are placed to moult. Also the hawk's indoor residence. *L., Camera; Mutatorium; Muta.*
- Mew.** *v.* To moult.
- Mewting.** *n.* Excrement of the long-winged hawks.
- Milan.** *n.* See **KITE**.
- Miliones.** *n.* *L.* Kites.
- Milvus regalis.** *n.* *L.* Kite (*q.v.*).
- Mites.** *n.* *Acari*. Parasites infesting the hawk's nasal cavities. See also **FORMICA**.
- Momey.** *n.* Gum (vegetable) remedy for hawks in the form of powder. See **MUMMY**.
- Morfex.** *n.* *L.* The white pelican.
- Moult.** *v.* To shed one by one (annually) old feathers (beginning with the seventh feather of the wing), thus acquiring a new plumage. *L., Mutare; Plumae exuere.*
- Mount.** *v.* To fly high in air; to soar or ring up (*q.v.*). *L., Accendere.*
- Mummy. Momey.** A mixture of fragrant herbs for treating avian diseases. Also the preservatives used in mummification. *L., Bumia* (Giorgio).

- Muschetus.** *n.* L. The male of the sparrow hawk (*q.v.*). The musket.
- Musket.** *n.* Male sparrow hawk.
- Muta.** *n.* L. Mews (*q.v.*). See also CAMERA; MUTATORIUM.
- Mutare.** *v.* L. To moult. See also PLUMAS EXUERE.
- Mutatio.** *n.* L. A moult (*q.v.*).
- Mutatorium.** *n.* L. Mews. See also MUTA; CAMERA.
- Mutatus.** *v.* L. Moulded.
- Mutatus falco.** *n.* L. A haggard (or hagar) (*q.v.*). A hawk that had moulted once before being trapped.
- Mute.** *v.* To excrete dung. L., *Fimum reddere.*
- Mutes.** *n.* Bird excrement. L., *Stercora, excrementa.* Important for diagnostic purposes.
- Nares.** *n.* L. Nasal cavities; nostrils.
- Nest.** Area of nidus.
- Nestling.** *n.* Very young bird. See also EYAS, NIDASIVS.
- Nidarius.** *n.* L. An eyas (*q.v.*).
- Nidasius.** *n.* L. Eyas or nestling (*q.v.*). Synonyms are *Nidarius*; *Nidularius*; *Clamorosus* (screamer).
- Nidularius.** *n.* L. An eyas (*q.v.*).
- Nidus.** *n.* L. Hawk's nesting place. See EYRIE.
- Nola.** *n.* L. A bell. See also CAMPANELLA.
- Nousle.** *v.* Old English. To nurse or cherish.
- Novellus.** Novella. See NOVITIUS.
- Novitius.** *n.* L. Unmade falcon; i.e., one that has forgotten or neglected parts of a training; a novice.
- Nutrire.** *v.* L. To feed up.
- Nyas.** *n.* An eyas (*q.v.*).
- Nye.** *n.* A brood or collection of birds—pheasants, for example.
- Oil gland.** Perunctum (*q.v.*).
- Osina.** *n.* L. Pelican.
- Ostringer.** Austringer. Astringer (Shakespeare). Astragus (Blome).¹ *n.* One who flies short-winged hawks; from the French *au(s)tour*.
- Overhawked.** *adj.* Having or attempting to keep too many hawks.
- Own the river.** *v.* Command the river (Blome).
- Pack.** *v.* To arrange a proper hamper for rail or other transport of hawks.
- Palsy.** *n.* Megrim (*q.v.*). A disease accompanied by chronic shaking of the hawk's head.
- Pannel.** *n.* The abdominal intestines, especially the lowest bowel.
- Pantas.** *n.* Disease of hawks resembling asthma.
- Passage hawk.** (L., *Peregrinus, fugitivus.*) *n.* A peregrine falcon captured during migration.
- Pattock.** *n.* The common kite, *Milvus migrans.*
- Pegging out.** *v.* Placing a hawk outdoors for a considerable time leashed to a block.
- Pelf.** *n.* See PILL.
- Pelt.** *n.* The dead body of a bird.
- Pendant feathers.** Those hanging down behind the thighs.
- Penna.** *n.* L. A feather. See also PLUMULA. The tuft of feathers adorning the hawk's hood (*q.v.*).
- Pennae affamatae.** *n.* L. Hawk's feathers showing effects of starvation or underfeeding (hunger traces).
- Perch.** *n.* The roost for indoor use on which hawks are placed. The high perch (*pertica alta*) in modern times is provided with a curtain or screen, unknown in the Middle Ages, by means of which the (bating) hawk is able to scramble back to her roosting place. The low perch, *pertica ima*, is not so provided. See also BLOCK; the block was used mostly for outdoor roosting.
- Peregrine.** *n.* One of the most important hunting birds in falconry. See PILGRIM.
- Peregrinus.** *n.* L. The passage hawk, pilgrim (*q.v.*), or peregrine falcon. See also FUGITIVUS.
- Pertica.** *n.* L. Hawk's perch (*q.v.*).
- Pertica alta.** *n.* L. The high perch (*q.v.*), for birds in the mews.
- Pertica ima.** *n.* L. The low perch (*q.v.*), for hawks in the mews.
- Perunctum.** *n.* L. The uropygium or oil-gland.

¹ See the Annotated Bibliography.

- Pelungere pennas.** *v.* L. To oil the feathers.
- Pes blaus.** *n.* L. One of the falcons.
- Petra. Lapis.** *n.* L. Internal avian disease accompanied by indurations in the intestines.
- Petty singles.** *n.* Toes of the hawk.
- Pilgrim.** *n.* Synonym (rare) for the peregrine (*q.v.*) falcon. The *Falco peregrinus* is a courageous, swift bird of almost worldwide distribution, called the duck hawk (*Falco peregrinus anatum*) in America. Probably the most valued of all the sporting falcons.
- Pili.** *n.* L. Woolly, hair-like feathers found in birds. See Book II, chapter viii, p. 117.
- Pill.** *n.* Pelf. Remains left by the hawk after feeding on her quarry.
- Pilositas pennarum.** *n.* L. Iridescence of the feathers.
- Pilula.** *n.* L. A casting (*q.v.*) or pellet. See also PLUMATA.
- Pin.** *n.* Bronchial disease. See CROAKS.
- Pin and web.** *n.* Dimness in and film over the eye.
- Pinnaria.** *n.* L. Hawk of the lure. See also LORARIA.
- Pisiculus indicus.** *n.* L. The porco, a small fish.
- Pitch.** *n.* The altitude reached by the falcon in ringing up.
- Pluerii.** *n.* L. Plover.
- Pluma.** *n.* L. A tuft or crown of feathers.
- Plumagium.** *n.* L. Plumage.
- Plumas exuere.** *v.* To moult; also *Mutare*.
- Plumata.** *n.* L. A casting up (*q.v.*) of feathers. See Book II, chapter xlvi, p. 157.
- Plume.** *n.* The mixture of feathers (plumage) and colors that identify a hawk.
- Plume.** *v.* To strip or pluck the feathers off the quarry; to deplume (*q.v.*).
- Pluming.** *n.* The decorative tuft on the crown of the hawk's hood. L., *Plumula*; *Penna*.
- Plumula.** *n.* L. The plume of feathers adorning the hawk's hood (*q.v.*); see also PENNA.
- Podagra.** *n.* L. Gout or similar "rheumatic" affection in birds.
- Point.** *v.* To "point"; said when the falcon throws herself or rises in the air above the place where the quarry has taken covert. "Making a point" is said of the falcon when she rises in the air and hovers over the locality where the quarry is in hiding.
- Pole.** *n.* A falconer's pole for use in vaulting ditches and brooks when afield.
- Pole cadge.** *n.* A padded and screened pole used for transporting several hawks (Michell).
- Pole hawk.** *n.* A live decoy bird raised on (or lowered) from the top of a pole; used in the capture of wild hawks.
- Pole pigeon.** *n.* A live decoy bird capable of being raised or lowered on a pole, for catching hawks.
- Pollex.** *n.* L. The "thumb" or protuberance in the bird's wing.
- Portatorium.** *n.* L. A cadge (*q.v.*).
- Poult.** *v.* To kill poultry.
- Pounces.** *n.* Talons.
- Praeda.** *n.* L. The quarry (*q.v.*) or prey of the hunting hawk.
- Preen.** *v.* To trim or dress (smooth up) with the beak. See TOWER.
- Prehendere.** *v.* L. To bind (*q.v.*). See also ARRIPERE.
- Pretender.** *n.* A temperamental falcon who shirks her duty. L., *Fictitius*, *Fictitia*.
- Prey.** *n.* The bird or other animal hunted in sports like falconry; the quarry.
- Prey upon.** *v.* To attack or kill.
- Pride.** *n.* A flock or gathering of certain animals; pheasants, for example.
- Pride.** *v.* To be in fine fettle or spirits.
- Principals.** *n.* The two longest feathers in a hawk's wing.
- Proicere loyrum.** *v.* L. To throw the lure.
- Prune.** *v.* To pluck at [herself]; said of the hawk who bites or picks at herself. See also RORDERE.
- Prynne.** *n.* An ophthalmia affecting hawks.
- Pugilarus.** *n.* L. Hawk of the fist; a short-winged bird.
- Pugnus.** *n.* L. The fist. See also MANUS.

- Pulsare.** *v.* L. To stoop (*q.v.*). See also **CAPEREA PRAEDAM.**
- Pulsus.** *n.* L. The swift downward plumage or stoop (*q.v.*) of the attacking falcon.
- Put in.** *v.* To drive the quarry to cover. See **ENEW.**
- Put over.** *v.* To transfer the gorge; said of the hawk when she removes the food from her gorge to the lower bowel by pressure on her body, chiefly on her neck.
- Quarred.** **Quarried.** *adj.* Said of the hawk that has successfully flown at her quarry.
- Quarry.** *n.* The game pursued or flown at by the hunter. The usual Latin term is *Corata*, or reward—the entrails of the dead prey given to the hunting animal.
- Quarry hawk.** Old, well-tamed bird used to enter younger birds in training.
- Quick.** *adj.* Alive.
- Quistula.** *n.* (L., *Quisquilla*, *Quaquillia*, *Quailia*.) The quail.
- Rake away.** *v.* To take off; to fly wide of or to avoid the quarry; used also when the falcon flies away, apparently for exercise or to amuse herself.
- Ramage hawk.** *n.* Hawk of the first year. See **SOAR**; **BRANCHER.**
- Ramagii falcones.** *n.* L. Young hawks; nestlings.
- Ramagius.** *n.* L. See **RAMALIS.**
- Ramalis.** **Ramelis.** **Ramarius.** **Ramagius.** *n.* L. A brancher (*q.v.*). A very young falcon, barely able to hop from branch to branch.
- Ramarius.** *n.* L. See **RAMALIS.**
- Rangle.** *n.* Small pebbles given the hawk to aid digestion. If placed near her block, she will take them voluntarily.
- Rape.** *v.* To claw or scratch.
- Rases.** *n.* Scrapings or shreadings.
- Recedere.** *v.* L. To rake away (*q.v.*).
- Reclaim.** *v.* To tame, gentle, and train a wild hawk. L., *Mansuefacere.*
- Reclamation.** *n.* Taming or training.
- Red hawk.** *n.* A sore (or sorrel) hawk; one less than a year old that has not moulted her first reddish-brown plumage.
- Refuse.** *v.* To decline; said of the hawk who declines to chase the quarry.
- Repulsatus.** *n.* L. A coward (*q.v.*).
- Retriever.** *n.* A dog, usually a setter or pointer, employed to flush game for the falcon who is waiting on for quarry.
- Revocare** [ad loyrum]. *v.* L. To lure (*q.v.*) the hawk from an assistant, as part of her training. See also **ALLECTARE**; **LOGORUM EXHIBERE AUT OSTENDERE.**
- Rick hawk.** *n.* One who flies to the top of a rick or other refuge to pluck and eat the quarry which she has carried off.
- Rings of metal.** See **ANNULI FERRULI.**
- Ring up.** *v.* To rise in spirals high in air; to mount or soar (*q.v.*). L., *Altiolare*; *Spiraliter aethera scandere.*
- Robin.** *n.* The male hobby.
- Rodere.** *v.* L. To tire (*q.v.*) or pluck at.
- Roserae.** *n.* L. Geese.
- Rouze.** *v.* Rouse. To bestir oneself; said when the hawk raises and shakes herself. Old English, *Rowysin.*
- Ruff.** *v.* To strike the quarry and make the feathers fly, but not to bind it.
- Rufter hood.** **Rufta hood.** *n.* A temporary, easy-fitting leather cover for the recently captured hawk, with a wide opening behind. Through a large aperture in front the bird can be fed; later her permanent hood is fitted. See **HOOD.**
- Rustica.** *n.* (L., *Rusticula*.) A variety of partridge.
- Rye.** *n.* Swelling of the head said to result from keeping the hawk without hot or fresh meat.
- Sacculus.** *n.* L. A sock (*q.v.*) for holding and partially binding the body of the hawk to keep her quiet. See also **MAIL**; **MALEOLUM.**
- Sahins.** *n.* A falcon; possibly Arabic slang for Shaheen.
- Sails.** *n.* The wings of the hawk.
- Saker.** *n.* A falcon (*Hierofalco sacer*) commonly used as a hunting bird, especially in the Orient. She resembles the American prairie falcon and the Indian lugger. This bird is sometimes mis-called the peregrine (*q.v.*).
- Sarcels.** *n.* Outer wing pinions.

- Saurus falco.** *n.* L. Unmoulted, sorehawk or red hawk (*q.v.*).
- Saxellus.** *n.* L. The first (primary) feather of the wing.
- Scouring.** *n.* Purgation.
- Screamer.** *n.* A young hawk in training, an eyas—usually fledgling, never a passage hawk—that has developed the vice of screaming.
- Screen perch.** *n.* See PERCH.
- Scurulus.** *n.* (L. *Sciurus.*) A squirrel.
- Sear. Cere.** *n.* Yellow patch between beak and eyes. See also SEARE.
- Searce.** *n.* Strain.
- Seare. Sere.** *n.* The cere or wax-like integument at the base of the beak.
- Sedge. Seige.** *v.* To stand at; said of herons on the water side. "At sedge" is the position of a water bird at the margin of a marsh or stream.
- Sedile.** *n.* L. A block perch (*q.v.*). See also SEDITORIUM.
- Seditorium.** *n.* L. A block (wooden or stone) perch for the hawk. See also SEDILE.
- Seel.** (Also, occasionally, *Seal.*) *v.* To blind by stitching the lower eyelid and attaching the ends of the threads to the head feathers; an early, cruel device, later abandoned for the hood. L., *Ciliare; Ciliatio.*
- Seige.** *v.* See SEDGE.
- Seize.** *v.* To take hold of; said of the hawk when grasping the prey with her talons.
- Semond.** *n.* Adhesive substance.
- Seraph.** *n.* (L., *Serater.*) Camelopard. Giraffe.
- Serve.** *v.* To put up the quarry for the waiting hawk.
- Set down.** *v.* To place in a mews to moult.
- Setting down.** *v.* Placing in the mews.
- Shaheen. Shahin.** *n.* Vulgar names for several valuable Indian hunting falcons. The black shaheen (*Falco peregrinator vel atriceps*) and the red-naped shaheen (*F. babylonicus*) are the best known.
- Sharp set.** *adj.* Very hungry.
- Slicing.** *v.* Muting a considerable distance (Blome).
- Slight falcon.** *n.* The female peregrine falcon, caught in early autumn, after leaving the nest, but before migration.
- Slight tercel.** *n.* The male peregrine falcon caught before migration.
- Slime.** *v.* To mute without dropping.
- Slip.** *v.* To cast off or fly (a hawk).
- Sloose.** *n.* Sloes; a mixture of sloes for hawks' diseases.
- Smerilio.** *n.* (L., *Emerilio.*) The merlin (*q.v.*); a small falcon (in America the pigeon hawk), *Falco aesalon*; also the merle (of Albertus Magnus).
- Sniting.** *n.* Sneezing.
- Snurt.** *n.* Cold in the head.
- Soar.** *v.* To rise spirally in air, to mount, to ring up (*q.v.*).
- Soarage.** *n.* Period before the first moult.
- Soarhawk.** *n.* Ramage hawk; one of the first year but able to hunt for herself. See SORE-HAWK.
- Sock.** *n.* Ankle part of a cotton stocking with slits in it for breathing, to be drawn over the head of the recently captured hawk (or over a hooded bird) to secure the wings, body, and legs. See MAIL; MALEOLUM; SACCULUS.
- Sorehawk.** *n.* A bird in her first year and before she moults. See RED HAWK.
- Sores.** *n.* L. A sore(sorrel)hawk. See RED HAWK.
- Sorrel hawk.** *n.* Red or sorehawk.
- Souse. Sowse.** *v.* To splash; to immerse.
- Sparrow hawk.** *n.* A small but important European, short-winged hunting bird (*Accipiter nisus*), the congener of the American sharp-shinned hawk. The male is called "musket." L., *Sparverius* and (the male) *Muschetus*.
- Sparverius. Spervarius. Sparvarius.** *n.* L. The sparrow hawk (*q.v.*).
- Spiral flight.** *n.* A soaring (aloft) in rings. L. (*v.*), *Volare regirando se.*
- Spring.** *v.* To flush the bird flown at.
- Spring swivel.** *n.* Device in hawk's furniture similar to that which attaches a watch to a chain. See SWIVEL.

- Stale.** *n.* A decoy (*q.v.*) bird; also a snare.
- Stalke.** *n.* Old English for the leg or the tarsus.
- Stand.** *v.* To be at; to have given up the chase.
- Starna.** *Sterna.* *n.* L. Partridge.
- Stately.** *adj.* Wild or shy.
- Staunch hawk.** *n.* One well entered for game.
- Stavesacker.** *n.* Stavesacre; larkspur or delphinium used as an insect powder for avian lice and other parasites.
- Stercora.** *n.* L. Avian excrement or mutes (*q.v.*).
- Stercus falconis.** *n.* L. The mutes or dung of the falcon.
- Sternum.** *n.* L. Breast bone.
- Sternutatio cum fluxu narium.** *n.* L. Catarrhal affection of the nasal passages in hawks.
- Stoop.** *n.* The lightning-like plunge of the falcon on the quarry beneath her. L., *Pulsus*.
- Stoop.** *v.* To make the swift swoop or thunderbolt descent of the falcon on the quarry from above.
- Stretch.** *n.* "At the stretch" means "in swiftest flight."
- Stretches.** *n.* Toes. Also meaning the feet of the hawk.
- Strike.** *v.* To rape, claw, or scratch.
- Strike the hood.** *v.* To ease the tight-fitting hood, so that it can instantly be removed when the falcon is to be flown.
- Subaxillaria ossa.** *n.* L. The axilla or armpit. See Book I, chapter xxxv, p. 72.
- Subducere.** *v.* L. To carry off, i.e., fly away with, the quarry.
- Suffusion of the eye.** *n.* Redness and swelling due to infection or cold.
- Summed.** *adj.* With a perfect array of fresh feathers after moulting and ready to be taken from the mews. See also FULL-SUMMED.
- Swivel.** *n.* Device for preventing twisting or entanglement of the hawk's jesses and leashes. See also TYRRIT; VARVELS.
- Syrena.** *n.* L. A bird (of doubtful species) mentioned by the author.
- Tackler.** *n.* An unusual name for a hack-hawk (*q.v.*); usually applied to an eyas trained altogether at hack and not in the mews.
- Tail to tail flying.** *v.* Said of a hawk which while chasing her quarry refuses to capture it.
- Take the air.** *v.* To mount.
- Take down.** *v.* To bring to the lure; generally said of falcons that are induced to return by a live pigeon attached to a cord.
- Take up.** *v.* To recapture a lost or strayed hawk.
- Talus falconis.** *n.* L. The posterior-lateral claw of the falcon, by means of which she disables or kills her quarry.
- Tame.** *v.* To reclaim or gentle while in training. L., *Mansuefacere*.
- Tarsell.** *n.* Spelling (Bert) of tercel (*q.v.*).
- Tartaret.** *n.* Synonym of Barbary falcon (*q.v.*).
- Tassel-gentle.** *n.* Male peregrine (Shakespeare).
- Tassell.** *n.* A Shakespearean synonym for tercel (*q.v.*).
- Tercel.** *n.* Also spelled tassel (Shakespeare), and tarsell (Bert). The male of any variety of hawk, as distinguished from the female, generally called *falcon*. The name is probably derived from the belief that the former is one-third smaller than the latter. L., *Tertiarius*; *Tertiolus*.
- Tertiarius.** *n.* L. Tercel (*q.v.*).
- Tertiolus.** *n.* L. The male of any hawk or falcon.
- Tetanus.** See CRAMP.
- Tewel.** *n.* The lower bowel.
- Throw off.** *v.* To cast off (*q.v.*).
- Thrush.** See FROUNCE.
- Tie up the tail.** *v.* To confine the tail feathers; this is done during the training of a hawk to prevent injury to the feathers.
- Tiercel.** An obsolete spelling of "tercel."
- Tiercelet.** *n.* A synonym of tiercel (*q.v.*).
- Timpanum.** *n.* L. Hand drum, used to flush the quarry.
- Tinca.** *n.* (L., *Tincha*.) A fish.
- Tinea balneatoria.** *n.* L. The bird's bath (tub).
- Tinnunculus.** *n.* L. The kestrel (*q.v.*).
- Tiratoria.** *Tiratorium.* *n.* L. A tiring; a tough piece of meat given the falcon to pull at, for the purpose of quieting the bird.

- Tiratorium carnosum.** *n.* L. Tiring, the fresh leg or wing of chicken, or similar fresh meat.
- Tiratorium nervosum.** *n.* L. The cold drumstick, or wing of chicken, with feathers attached. A tiring with very little nourishment. *See* TIRE.
- Tire.** *v.* To feed a tough morsel or bechin (*q.v.*) at a tiring (*q.v.*).
- Tiring. Tying.** *n.* A tough piece of meat, for instance a leg or wing with little flesh on it, given a hawk to pull at for the purpose of quieting the bird or of prolonging the meal and exercising the muscles of mastication and deglutition. *See* BECHIN.
- Tornettum.** *n.* L. Varvel; one of two flat rings that together constitute a swivel (*q.v.*).
- Tower.** *v.* To ring up or fly straight up in the air; to preen herself and raise her wings.
- Trahina.** *n.* L. A form of the lure used in educating the young falcon; usually a live bird attached to a creance. *See* TRAIN; TRAYNA.
- Train.** *n.* Tail of the hawk. L., *Cauda*. Some captive quarry, dead or alive, attached to the creance to attract the hawk.
- Train.** *v.* To educate. L., *Instituere, Educare, Curare*.
- Training.** *n.* The education (of a hawk). L., *Cura, Curatio*.
- Trayna.** *n.* L. *See* TRAHINA.
- Traynare.** *v.* L. To train. *See* TRAHINA.
- Truss.** *v.* (*a*) To seize and soar with the quarry into the air, at length descending with it to the ground. (*b*) To bind the wing or wings of a hawk to its body.
- Tunctatus falco.** *n.* L. A variety of hunting bird.
- Tyrrit.** *n.* *See* SWIVEL.
- Ungues.** *n.* L. Talons.
- Ungues aptare.** *v.* L. To cope (*q.v.*).
- Unhood.** *v.* To remove the hawk's hood from her head. L., *Capellum deponere*.
- Unmade.** *adj.* Immature, untrained. *See* NOVITIUS.
- Unreclaimed.** *adj.* Wild; said of a wild hawk.
- Unstrike the hood.** *v.* To draw the strings of the hood that it may be ready to be removed quickly and with ease when needed.
- Unsummed.** *adj.* With plumage not fully developed.
- Urines.** *n.* Nets for catching hawks (Cox).
- Urives. Urves.** *n.* Nets for catching hawks (Blome).
- Uropygium. Perunctum.** *n.* L. The oil gland. Cf. Book I, chapter xxxi, p. 71.
- Vadare.** *v.* L. To head the bird in a certain direction.
- Vani. Vanni.** *n.* L. Secondary flight feathers (*q.v.*). *See also* CULTELLUS (primaries).
- Varvels.** *n.* Small flat rings through which the leash was passed, used instead of a swivel. The owner's name was engraved on this device and it was attached to the jesses. *See also* VERVELS (Blome).
- Venari cum avibus.** *v.* L. To hawk.
- Venery.** *n.* Hunting as an outdoor sport.
- Vervels.** *n.* *See* VARVELS.
- Viridis pedum color.** L. Yellow-footed hawk (sign of age in some birds).
- Volare girando se.** *v.* L. *See* VOLARE REGIRANDO SE.
- Volare huc et illuc.** *v.* L. To fly at hack.
- Volare regirando se.** *v.* L. To fly up in rings or spirals, to ring up.
- Volatus.** *n.* L. Flight.
- Volatus falconum.** L. The falcon's flight: the swift (spiral) upward flying (*celeri volatu ascendere*); the indirect descent (*ex obliquo in arcu descendere*); the stoop or direct lightning plunge and stroke (*ponit et ictum dat*); and, finally, the hovering in mid-air (*alis suspensis pendere in aere*).
- Volatus falconum ad cortum prurientium.** L. Sexual cry of the falcon.
- Wait on.** *v.* To hover and wait for the attack; said of the falcon circling above the falconer and waiting for the quarry to be flushed. L., *Circumvolare, Expectare*.
- Walm.** *n.* A bubble in boiling.
- Warbel.** *n.* Synonym of warble (*q.v.*).

Warbile. *n.* Synonym of warble (*q.v.*).

Warble. *n.* The act of the hawk when, after mantling (*q.v.*) and rousing (*q.v.*), she settles her wings normally, i.e., crosswise over her back.

Warble. *v.* To cross the wings over the back.

Watching. *n.* An ancient method of taming a hawk, i.e., holding her on the fist and otherwise keeping her awake without food for the first day and night after capture.

Weather. *v.* To place the hawk outdoors on a block. An *eyas* or very young captive may be left unhooded all the time, or after a gorge, in the open air; but an untamed bird, a haggard for example, ought to be placed on the block

in the early morning, or in the evening before she is fed, and should always be hooded to prevent bating and thus hindering her reclamation. L., *Foras portare*.

Weathering. *n.* See WEATHER.

"Who-whoop!" The death cry of the falconer when he sees the falcon clutching the quarry.

"Why loe!" The shout by which the falconer calls in a raking hawk.

Wind up. *v.* To entangle a recaptured hawk by gradually winding a string about her feet.

Wreath. *n.* Fore part of the hawk's neck.

Yarak. *adj.* Oriental term describing a hawk in all respects fit and eager to hunt.

Zueta. Ziguetta. *n.* L. One of the owls.



GENERAL INDEX

- Abacist monk's method of counting, 143
- Abandonment of young, 45; in birds of prey, 56, 110, 118
- Abram, A., xxxv
- Acari, *see* Parasites, external
- Accipitres*, *see* Hawks
- Aelian, lxxxi
- Albertus Magnus (Count von Bollstadt), xlviii, lxx, lxxvi, lxxx
- Al-Kamil Muhammad, Sultan, xxxviii
- Ancestors of Frederick II: Hohenstaufen, 475-82; Norman, 482-87
- Anderson, John, 451
- Anglicus, Master Walter, and his son William, falconers, xlii
- Animal park of San Lorenzo, xcv
- Anjou-Sicily, lviii
- Anointing of feathers, 192, 202
- Aptha, 427
- Apoplexy, 427
- Apulia, xlii, xlvii, xcv, xcvi, xcvi, cxiii, 53, 493
- Arabia, capture of hawks in, 442-47, 448; doves used in, xli; live lures used in, 227
- Aragon-Sicily, coat of arms of House of, lxi
- Aristotle, xxxvii, xxxix, xlii, 3-4, 7, 9, 15, 19, 30, 40, 61, 108
- Armenia, Island of, hare-train used in, 255
- Ascarides, *see* Parasites, internal
- Astore Manfredi II, lx, lxi
- Astore Manfredi III, lxi
- Augustales, 503; specimens of, cxliii
- Avicenna, xxxix; *see* Bibliography
- Bari, Emperor's castle near, xcv, xcvi, cv
- Barletta, castle at, xcv, xcvi, 496
- Barnacle goose, 51
- Barron, F. T., 461
- Bastard wing (*empiniones*), 83, 89
- Bathing the falcon, 157, 170, 191-93, 203, 214, 251, 426
- Bathtub, 106, 130, 191, 419; mews and, 125, 421
- Bating, xl, 169; causes of, 178, 203; forms of, 175-76, 183; illustrations of, 423, 435; in improperly manned falcon, 202-3; precautions against, 177, 183, 190, 191; prevention of, 179-81, 191, 203; rescue from, 181; symptoms of, 178
- Bavaria, *see* Elizabeth of, and Margaret of
- Beaks, of birds, 61-63, 77; illustrations, 66, 68
- Bekker, John, 451
- Bells, falcon's, lx, 137, 140; illustrations, 141
- Belvallette, Alfred, 452 and Bibliography
- Bianca Lancià, 495
- Bibliography of falconry, 559-609
- Bibliothèque Nationale MS. Fr. 1296, *De Arte Venandi cum Avibus*, lvii, lxxv
- Bibliothèque Nationale MS. 12400, *De Arte Venandi cum Avibus*, lvii, lxxi-lxxiii, lxxiv; illustrations from, xxxii, lxiii, 11, 13, 85, 125, 188, 438
- Biedermann, Baron Christoph von, 452
- Binding to one another, 246, 247, 250; to the quarry, 290-95
- Birds: classification of, 79; land, *see* Land birds; migration of, *see* Migration, avian; modes of flight in, *see* Flight; nesting of, 49-52, 111-12; neutral, *see* Neutral birds; nonmigratory, 45; nonraptorial, 9; organs and tissues of, 57-79; plumage of, 58-59, 79-91, 117, 121-28, 274; roster of, known to Frederick II, 531-56; *see also* Birds of prey, and Birds of the chase, favorite
- Birds of the chase, favorite, 507-27
- Birds of prey, 9, 10, 96, 107-27; care and feeding of young, 54, 55, 117; definition of, 107; distribution of, 10, 111-12; driving off young, 56, 110, 118; feeding habits of, 20-21, 28-31, 108, 118; female larger than male, 108; hunting at night, 30, 118, 119; migration of, 118-19; modes of flight in, 28; moult of, 98-99, 425-26; nesting habits of, 111; night refuges of, 30; nomenclature of, 10; ovulation in, 112; plumage of, 117; training young to hunt, 117-18; used in falconry, 110, 507-27; warm nature of, 108-9, 112
- Bitonto, cathedral at, 23, 332
- Blain, the, disease of birds, 428
- Blaine, Gilbert, 449, 452
- Block (or stool), xl, 106, 158, 161-62, 173, 192, 419, 420; block perch, illustration, 167; placing falcon on, 164; use of various stools and perches, 162
- Blunting, *see* Coping
- Boccaccio, xxxvi
- Bodleian MS. of the *De Arte Venandi cum Avibus*, lvii, lxii
- Böhmer-Ficker, xlii
- Boke of Saint Albans*, 526
- Bollstadt, Count von, *see* Albertus Magnus
- Bologna MS. of the *De Arte Venandi cum Avibus*, lvii-lviii, lxi, lxii, lxxxi, lxxxii-lxxxvii; incipit, liii, 375; folio 34, lxxx
- Boyer, A., 452
- Brain, and internal organs of bird, 76
- Branchers, capture of, 144; compared with eyases, 128; feeding of, 160; modes of flight of, in heron hawking, 350-51, 354; training, 256
- Breast, or thorax, 71-72
- Brienne, Iolanthe (Yolanda) of, 476, 488
- Brienne, Walter of, 488
- Brindisi, xcv, xcvi, 488; castle at, xcv
- Britain, xlvii; falconry in, 449, 451, 452; luring in, 243-44; nests of saker in, 111
- Brodrick, *see* Salvin and
- Bronchial tubes, 78
- Bulgaria, saker falcon in, 111
- Cadges, 420; padded, 148, 429
- Cage, for trapping, 444
- Calls, use of, 159, 174, 179, 184; in Britain, 243; in luring, 231, 239; when hawking at the brook, 365-66, 373, 374, 379, 392, 393, 394, 407, 408, 411, 413
- Capitanata, the, birds of, xlii, xlvii, xcvi, 44
- Capture of hawks and falcons, xl, 106, 128, 129, 144-46, 433-49; with birdlime, 447, 448; box-cage

- trap for, 445; care required in, 441; Demeritt-Meredith trap for, 446, 448; Dho-gaza, or Arab and Persian trap for, 442-47; Dutch method of, 439-42; "Eerwan," trap for, 447; with a free-flying pigeon, 447; Gilbert Blaine's trap for, 449; illustrations, 443-46; Persian method for, 449; terrain suitable for, 433-34; by trained falcons, 447; traps and snares for, 439-49
- Capua, towers of, xxxix, ciii
- Carrying the falcon (or hawk), xli, 143-44, 424; through a doorway, 189; on horseback, 172-73, 189; indoors, 158-59, 170, 175; outdoors, 172; in wind, 190, 193, 194
- Cast, falcons to be flown in a: disqualification of, 246; testing, 246, 247; unwillingness of, 246, 248; use of hare-train for, 249
- Castel Fiorentino: death of Frederick at, 493
- Castel Gioja del Colle, cv-cvi; courtyard of, 24; loggia in court, xlv; palace, 25; throne from audience chamber, xlv
- Castel del Monte, xlv, xcv, xcvi-cv; doorway, 221, 263; Frederick's bedroom, 253; main portal of, xcix; near view of, cx; plans and section of, ci; terrain near, 224
- Casting off, illustration showing, 291
- Castings (of feathers), 157, 161
- Castles and hunting lodges of Frederick II, xxxvi, xcv-cv; *see* List of Illustrations
- Charles of Anjou, xcvi, 495, 496, 497
- Checking, in crane hawking, 295; in hawking at the brook, 371, 408-9; in heron hawking, 325, 338-39; *see also* Raking away
- Cheseman, Robert, falconer, 102
- Chicken hawk, *see* Goshawks
- Ciliation, *see* Seeling
- Cistercian monks, xcvi
- Classification of birds, 7-8, 9-14
- Claws, birds', 75; illustrations of, 86
- Cleghorn, J. D., 461
- Climatic zones, 39, 40, 51, 111, 112, 320-22
- Clubs, falconry, 451-52, 459
- Coins, 561; illustrations, 466-70; *see* Augustales
- Coins and medals, 466-70, 471-72
- Cold ration, *see* Tiring
- Conrad IV, Emperor, 475, 476, 488, 493, 495
- Conradin, 496-97; statue of, 500, 501
- Constance (daughter of Manfred), lxi, 476, 496, 497-98
- Constance of Aragon, Empress, 476, 488; crown of, 478
- Constance of Sicily, Empress, xxxvi, 476, 482, 487; tomb of, 479
- Constitutions of Melfi, lxxxiv, xcvi
- Consumption, *see* Tuberculosis
- Coping (or blunting), 137, 138, 149, 427; illustration, 132
- Corns, *see* Cysts, indurated
- Cowards and shirkers, in crane hawking, 303-6; reasons why falcons become, 306-7; treatment of, 307-8
- Crabbing, *see* Binding to
- Cramp, *see* Tetanus
- Crane hawking, 273-311; assistants, use of, 283-85, 288, 290; assisting falcon unable to bind to in, 293-94; binding to in, 290; checking in, 295; cowards and shirkers in, 303-8; entering novice with make-hawk, 296-98; entering novice in, 279-80; entering two novices in, 298-99; hours for, 277-78; localities for, 278; position of falconer in, 285-88; reasons for not binding to in, 294-95; rewarding the falcon, 290; seasons for, 274-76; separating standing cranes in, 281-82; slipping the falcon, 288-89; use of dogs in, 288, 289-90; weather for, 276-77; in wind, 283-87
- Cranes, 8, 34, 58, 71, 76, 96; call of, 261; carrying, 258; feeding habits of, 273-74; plumage of, 274; separating standing, 281, 282; signs that cranes will remain quiet, 282; used in a train, 257-67; *see* Gerfalcon
- Crane-train, 106; making of, 257-58; meat on, 258, 259, 260; used to train gerfalcons, 257-66; value of, 266
- Creance (or line), xl, 106; use in luring, 229, 230-31, 238, 240
- Crests, of birds, illustration, 38
- Croaks, kecks, and pin, 427
- Croesing, Henri, 461
- Cross references in *De Arte Venandi cum Avibus*, lxxxv-lxxxvii
- Crusade, Frederick's, xxxix, 488
- Crusades, xcvi, 482, 483, 487, 488, 493
- Cuckoo, 49, 53
- Curtain, *see* Screen
- Cysts, indurated, 428
- Daims, John, 452
- Dall'Antelle, Simone, sonnet by, 494
- Dampierre, Jean II, Lord of, lxx
- Daniele bust of Frederick II, 503; *see* Portraits
- Dante Alighieri, xxxvi; quotation from *Purgatorio*, 496
- Darkened room, use of, 158, 172, 181, 204, 251
- Daude de Pradas, xlvi
- De Arte Venandi cum Avibus*, xxxv, xli, xlii, xlvi, xlviii, cv; dedication of, lvii, lviii, lxi, lxii, lxxiii, lxxiv, lxxxiii-lxxxiv, 3; illuminations and illustrations of MSS. of, xxxviii, lviii, lx, lxi, lxii, lxix-lxx, lxxi, lxxii-lxxiii, lxxiv; manuscripts and editions of, xxxviii, xlii, lvii-lxxxvii; sources of, xxxviii, xxxix; translation of, 3-414
- Defense: avian offense and, 95, 96, 97; of young, 55
- Dentice di Frasso, Prince Pietro, 452
- Descendants of Frederick II, 497-98
- de Thou, Jacques Auguste, *see* Thuani
- Deutscher Falkenorden*, 452, 459; Reichsfalkenhof of, 233, 458, 523
- Diaphragm, in birds, 78
- Diseases of and accidents to hawks, 19, 381, 425-31; to falcons, book on, xxxvi
- Dobrée, Thomas, lx, lxxv
- Dogs, 158, 242, 250, 252; avoiding, 371; choice of, 267-68; training, 268-70; use in crane hawking, 281, 288, 289, 290; use in heron hawking, 328, 330-31, 341, 346
- Dorsal region, 70
- Drawer, *see* Tiring
- Drum, falconer's, xl, 106, 400-401
- Duck hawking, *see* Hawking at the brook
- Ducks: entering eyases to, 410; falcon stooping at, 401-2, 410; lure made of mallard wings, 363; objects mistaken for, 410-11; putting up, 392, 394, 400-401, 404, 410-14; slipping falcon at, 387
- Eagles, xxxix, 28, 109, 525-26
- Ears, of birds, 60
- Eggs, cviii, 52-53; falcon's, xl; incu-

- bation of, xxxvii, xlvi, 53; *see* Nests
- Egypt, 53, 58, 321
- Eleonora falcon, 517
- Elizabeth of Bavaria, 496
- Emaciation, 160
- Emarginate feathers (the "knives"), 83, 89
- Engelmann, Fritz, 471
- Enzio, Frederick's son, 476, 493, 496
- Epilepsy, 427
- Esophagus, 78
- Experiments of Frederick II, xlvi, 22, 49
- Eyases: compared with branchers, 128; eggs and milk for, 134-35; entering to ducks, 410; feeding and care of, xl, 129, 130, 133-35; flight, modes of, 350, 372-73; training, 256; used in heron hawking, 354
- Eyes, of birds, 59-60
- Faenza, Astore Manfredi II of, lx, lxi
- Faenza, Astore Manfredi III of, lxi
- Faenza (city), siege of, xlix
- Falcon: definition of, 107, 110, 508; illustrations, 116, 132, 166, 188, 199, 200, 212, 236, 272, 291, 314, 360, 361, 424, 435, 455; transport for, 457
- Falconer: aims and duties of, xli, xlii, 106, 110, 151-52; equipment of, 106-51; equipment in crane hawking, 280-81; qualifications of, 105-6, 150-51
- Falconers: Frederick's, xlii; illustration (color), *facing* 3; modern, 451-52, 456, 460-61
- Falconry (the "noblest of arts"), xxxv, xcvi, cv, 3-7, 105; clubs, 451-52, 459; coins and medals depicting, 471; in modern times, 451-61; in America, 434, 448, 459, 461; Arabia, 442, 448, 460; Asia, 460; Britain, 449, 451-52; Germany, 452-59; Holland, 439, 452; India, 460; Persia, 442; Russia, 460; Syria, 460, 488
- Falconry terms, Glossary of, 613
- Falcons: bathing, *see* Bathing falcons; bating in, *see* Bating; beaks of, 108; bells for, 137, 140; book on, lxxxvi; capture of, 112 (*see also* Capture of hawks and falcons); diseases of, 19, 381, 425-31; eyes of, 60; fatigue in, 203, 204, 245; feeding, 135-36, 158-59, 160, 166, 251, 427; flight of, 108, 244-45, 299, 300-301, 365, 386; flown in cast, 246-49; fractures in, 431; health in, 107, 136, 157, 193, 425; how to recognize, 119; improperly carried, 203, 205; list of, used in sport, 527; nesting habits of, 111; rank in, 526; recently captured, xli; restlessness in, 169-70; seeling eyes of, lx, lxi, 137-38, 146, 157, 158; slipping falcon, in crane hawking, 285-86; slipping in heron hawking, 343-44, 349, 350; transport of, 457; travel with, 195-205, 216, 217
- Falkenorden, German, 233, 451, 452, 459; Reichsfalkenhof of, 114, 233, 234, 458, 523
- Fear of man in raptorial, 6, 152, 219, 225, 384
- Feathers: anointing of, 192, 202; emarginate, 83, 89; flight feathers in wing, 83, 84, 89, 117; flight feathers in tail, 83, 89; repair of, *see* Imping; swing (or saxellus), 83, 84; *see also* Plumage
- Feet, of birds, 72, 73, 86
- Ferdinand of Austria, lxxvi
- Fish eagle (or osprey), fish hawk, 8, 10, 109; illustration, 26
- Fleming, Arnold, 451, 456, 527
- Flight, modes of, in birds, 91, 92, 93, 94, 393, 394; in eyases, 350; in branchers, 350-51; of sakers, 327-28; *see also* Falcons, flight of
- Foggia, xcv; Frederick's palace at, xcv; illustrations, xcvi
- Foix, Gaston Phebus, Comte de, lxxiv; incipit of *Le Livre de la Chasse*, lxxviii, lxxix
- Fractures, 431
- Frederick of Baden, 497
- Frederick I (Barbarossa) of Hohenstaufen, Emperor, xxxv, lxxvi, cv, 481-82; genealogy, 476
- Frederick II of Hohenstaufen, Emperor, xxxv, xxxvi, xxxvii-lxxii, xcv-cvi, 475, 476, 482, 487-93; administration of, xcvi-xcvii; architecture of, xxxvi, xxxix, xcv-cv; as author, 3-5, 425, 433, 507; birds of the chase known to, 507-27; castles and hunting lodges of, xxxvi, xcv-cv; conflicts with Papacy, 488-93; crusade of, xxxix, 488; experiments of, xlvi, 22, 49; Hohenstaufen ancestors, 475-82; Norman ancestors, 482-87; poem of, 493-94; portraits of, xxxix, lxix, lxxi, lxxvi, 471, 503-4; roster of birds known to, 531-56
- Frederick William II, King of Prussia, lxxvi
- Frounce, 427
- Galitzine, Prince Nicholas, 460
- Gauntlet, *see* Glove
- Geneva MS. of *De Arte Venandi cum Avibus*, lviii; incipit, lxiv
- Gerfalcon, xxxix, 110, 111; capture of, 145-46; definition of, 111; description of, 120-21, 509-10; feeding, 160, 251; feeding in training, 257, 259, 260, 261; nesting habits of, 111; plumage of, 121; rest period for recently acquired, 251; training of, 250-67 (*see* Training); used in heron hawking, 352
- Gioja de Colle, *see* Castle Gioja
- Glossary of falconry terms, 613
- Glove (or gauntlet), falconer's, xl, 106, 151, 400-401, 407, 408, 411, 413, 414
- Goose, used in training dogs, 269
- Göring, Hermann, 459
- Goshawks, xxxix, 110, 519-20; apoplexy in, 427; illustrations, 513, 524; nesting of, 112
- Gravina, xcvi
- Greenland, xlvi, 111
- Guicennas, or Guillinus, or G. Persicus, lx
- Hack house, *see* Mews
- Hacking, perch for, 167
- Hampe, Karl, xxxviii
- Handling: effects of bad, 251; methods of, 435
- Hare-train, 106, 252, 255; for flying in a cast, 249
- Harting, James Edmund, xlvi
- Harvey, George, 451
- Haskins, Charles H., xxxvi, xxxviii, xxxix, xlii, xlvi, xlvi, xlix, l, lvii, lxxxix
- Hawking at the brook, 363-414; assistants used in, 391, 392, 403, 404, 410, 412-14; assisting peregrine, 402-8; birds that frighten a falcon, 387, 388, 390, 391, 394, 400, 408; calling down falcon with lure, 404, 407, 408, 409, 410-11, 413; choosing best peregrines for, 364-65; ducks rising of own accord when, 411; failure of falcon to capture quar-

- ry, 404, 408, 412; falcons' modes of flight, 386; localities for, 385, 387; lure made of mallard wings, 363; luring peregrines for, 364-65; objects mistaken for ducks, 410-11; putting up quarry, 392, 394, 400-401, 404, 410-14; raking away, reasons for, 388-90, 391; recovery of falcon, 391, 400, 413-14; rewarding the falcon, 403, 404, 410; seasons for, 385; slipping the falcon, 387; stooping at quarry, 401-2, 410; training falcon for, *see* Waiting on; weather for, 385
- Hawks (*accipitres*), 112; book on, lxxxvi, 419; definition of, 110, 508; diseases of and injuries to, 19, 381, 419, 425-31; fish hawk, 26; furniture of, illustration, 142; illustrations, 115, 142; long-winged, 508-19; short-winged, 508, 519-25; *see also* Falcons; Goshawk; Sparrow hawk
- Hawks' furniture, collection of, 461
- Head, 58; illustrations, 38, 65
- Health of falcons, 107, 136, 157, 160, 193, 425
- Henry, King of England, book of, xlviii
- Henry VI of Hohenstaufen, Emperor, xxxv, 475, 481, 482; genealogy, 476
- Henry VII of Hohenstaufen, 488, 493, 494
- Heron hawking, 317, 357; at the river, 329; assistants used in, 326-28; assisting a poor falcon in, 345; assisting the saker in, 330-31; with branchers and eyases, 354; checking in, 325, 338-39; dogs used in, 328, 330-31, 341, 346; entering the falcon in, 326-27; falcons used in, comparison of, 353-57; failure to capture quarry in, 336-38; with a gerfalcon, 353; hazards of wind and terrain in, 346-48; hours for training saker for, 324-25; with a laner, 354; localities suited to, 325; modes of flight of eyases, 350; modes of flight of branchers, 350-51; modes of flight of sakers, 327-28; with peregrine, 353; position of falconer in, 349-58; recovery of falcon in, 336; rewarding the falcon in, 330; seasons for training for, 323-24; slipping the falcon in, 343-44, 349-50; testing a falcon for, 348; training a saker for, 317-20; use of lure to recall falcon, 337; use of make-falcon in, 338, 339-42; weather for training, 324; wind bad for training, 325
- Hérons, 34, 93, 94, 96; feeding of, used in train, 317-18; methods of escape of, 342, 348; migration of, 321, 322; nesting and feeding habits of, 320-21; on passage, 349; putting up, 343-45; used in train, 317-32
- Heron-train, 106, 317-20; feeding herons for use in, 317-18; used to train sakers, 318, 320
- Hibbard, Margaret, 461
- Hippocrates, aphorisms of, xxxix, 135
- Hips of birds, 70, 72
- Hitti, Philip K., xxxvi
- Hobby, 29, 110, 517; lice on, 428; illustrations, 47, 271, 315, 512
- Hohenstaufen, *see* Ancestors
- Hood, xli, 106, 205, 206; adjusting, 207-8; advantages of, 217, 219; comparison of its use with that of tiring, 217; falcon's objections to, 208-13, 214; handling of, inexperienced, 215; ill-fitting, 215; illustrations, 142, 198, 209; loss of, 217; removal of, 213, 289, 371, 387; shyness, 382; use of, 206-19, 289
- Hooded falcon: bathing, 214; carrying two, 218; taming, 189; transporting, 216-19; transporting in various seasons, 216; unseeling, 214, 217; weather for transporting, 217
- Horse: dismounting, 173; illustrations showing mounting, 187, 188; mounting, 173, 194; qualifications of falconer's, 281
- Hounds, *see* Dogs
- Hunger traces in falcon's plumage, xl, 426
- Hyderabad, Nizam of, 460
- Ibn Sab'in, xlvi
- Iceland, xlvi, 111; falcon (illustration), 361
- Idrisi, Abu Abdallah Mohammed, xlvi, 39, 486
- Illustrations, list of, xxi-xxvii
- Imperial Seal, 415, 504
- Imping, 426
- Incubation of eggs, *see* Eggs
- Injuries to hawks, *see* Diseases of and accidents to hawks
- Iolanthe (Yolanda) of Brienne, *see* Brienne
- Isabella of England, 495
- Jack, T. A. M., 452
- Jesses, falcon's, xl, xli, 106, 137, 138-39, 281; designs for, 132
- Joachim Camerarius, lxx, lxxvi
- Junklaus, Friedrich, 452
- Kecks, 427; *see* Croaks
- Kestrels, 28, 518-19
- Kidneys, 79
- Knight, Hugh D., 452, 471
- Lagopesole, xcvi; castle at, cii
- Land birds, 7, 8, 19, 49, 51, 63, 107; care and feeding of young, 53-55; feeding habits of, 19-22, 62; refuges of, 97
- Lanner falcons, xxxix, 110, 517; capture of, 145; description of, 127; illustration, 168; nesting of, 111; plumage of, 127; used in heron hawking, 354
- Leash, falcon's, xl, 106, 137, 139-40; used in luring, 229, 230, 243
- Legs, 72; illustrations of feet and, 86
- Lice, *see* Parasites, external
- Lifting falcon from perch, 184
- Line, *see* Creance
- Liver, 79
- Louis de Bruges, Seigneur de la Gru-thuyse, lxxiii
- Louis XII of France, lxxiii
- Lucera, Castle and Saracen camp of, xxxvi, xcv, xcvi, ciii, 493; plan of, xciii; tower of fortress, 545
- Luciani, S. A., lxix, lxxxii, lxxxiii
- Lugger falcon, 517
- Lungs, 78
- Lure, xl, xli, 106; dislike of, 244; feeding falcon on, 230, 232, 244; hiding, 247, 248; lifting falcon from, 237, 379; live, evil results of, 227-28; made of crane's wings, 225-27; made of heron's wings, 317; of mallard drake's wings, 363; meat on the, 229, 232, 244; reasons for peregrine's dislike, 366-68; tossing of, 240; use of, in Arabia, 227; use indoors, 228; use outdoors, 228-29; used to test falcon's mode of flight, 244; used to test falcon's flight in a cast, 246, 247-48
- Luring: assistants required in, 238; in Britain, 243-44; Emperor's method of, 229-43; feeding a falcon when luring, 232; in heron hawk-

- ing, 317; on horseback, 241-43; hours for, 238; localities for, 237; removal of hood before, 230; use of calls in, 231, 239, 241, 242, 243; use of creance in, 229, 230-31, 238, 240; use of leash in, 229, 230; without creance, 240-41; in wind, 239
- Make-hawk, use of: in crane hawking, 296-98; in heron hawking, 338, 339-42
- Malay Islands, capture of hawks in, 448
- Maleolus* (sock), 106; illustration, 165
- Malik El-Kamil, Sultan of Egypt, lxxxiii
- Malik-es-Salih, Sultan of Egypt, lxxxiii
- Malik, Mohammed Umar Hayat Khan, 452
- Mandibles, *see* Beak
- Manesse MS., Geneva, 499
- Manfred, King of Sicily, xxxviii, xlii, xlvii, xlvi, lxxvi, lxxxiv, lxxxvii, xcvi, 495-96, 497; additions to the *De Arte Venandi* by, lxxxi, lxxxiv, lxxxvii, 9, 15, 17, 19, 30, 91, 92, 119, 120, 171, 181, 182-84, 192; portraits of, xxxi, xxxiii, xxiv, 14
- Manuscripts of the *De Arte Venandi cum Avibus*, xxxviii, xlii, lvii-lxxxvii; folios from, xxxi, xxxii, xxxiii, xxxiv, liii, liv, lv, lvi, lxiii, lxiv, lxv, lxvi, lxvii, lxviii, lxix, lxxx, 11, 12, 13, 14, 35, 36, 37, 38, 67, 85, 86, 87, 88, 126, 131, 156, 375, 423; *see De Arte Venandi cum Avibus*
- Map of southern Italy, xci
- Margaret of Bavaria, 494
- Markwald of Anweiler, 487, 488
- Mating, 45-49; of raptorials, 46
- Mazarine MS. of the *De Arte Venandi cum Avibus*, xlii, lvii, lviii-lxi, lxi; incipit, liv
- Menagerie, Frederick's, xxxvii, xlvii, xc
- Meredith, Captain R. Luff, 433-49, 459
- Merlin, 110, 427, 428, 518; illustrations, 48, 313
- Mews (or hack house), 107, 129-30, 136, 146, 419-20; illustrations, 125, 126; perches in, 161-62, 419; removal of falcons from, 136-37; ventilation of, 130, 420
- Michell, E. B., 509, 518
- Migration, avian, xxxix, 31-45, 95; causes of, 32-33, 42; comparison of spring and autumn, 44; illustration, 35; limited, 42; order of, 39, 40, 42, 43; preparation for, 33; seasons for, 31, 43; in the tropics, 32; weather for, 34, 95
- Migratory birds, 32, 44; summer quarters of, 43; winter quarters of, 40, 41
- Moamyn, Arab falconer, xlix, lx
- Mollen family, 439, 452
- Mollen, Karl, 452, 454
- Monreale, pillars of Cathedral at, 222
- Moore, Rev. Philip, lxxxii, lxxxiii
- Morey, Professor C., 473
- Moult of birds, 97-99, 425-26, 507
- Moulting house, *see* Mews
- Muscles, 76
- Nantes MS. of *De Arte Venandi cum Avibus*, lvii, lx-lxi, lxxv; *see also* Pichon, Baron Jérôme
- Neck, 63; illustrations, 67
- Nesting of birds, 49-52, 110, 111-12; season for, 50; sites for, 51
- Nestlings: abandonment of, 55-56; care and feeding of, 53-56, 130-33; plumage of, 79-80, 81; *see also* Eyases
- Nests: illustrations from early manuscripts, 437, 438
- Net, for catching birds of prey, 444
- Neutral birds, 7, 8, 17, 49, 51, 63; feeding habits of, 17, 22-27, 62; sleeping habits of, 18-19, 27
- Newcome, E. T., 452
- Nicola Pisano, cv
- Nile River, herons near, 321-22
- Noble, true, falcons, *see* True noble falcons
- Noël, M., 452
- Nonmigratory birds, 44, 45
- Nonraptorial birds, 9
- Nordenskiöld, Erik, xxxvii, 1
- Norway, home of gerfalcon, xlvii, 111
- Norway falcon, illustration, 210
- Novice falcons: entering to cranes with make-hawk, 296-98; entering, to herons, 327; entering to herons with make-falcon, 339-42, 385; entering two, 298
- Oil gland, 71
- Onolzbach, Margrave and Prince of, lxxvi
- Organs and tissues, 57; external, 57-76; internal, 58, 76-79
- Osborn, E. T., 503
- Osprey, *see* Fish eagle
- Ovaries, *see* Testes and ovaries
- Ovulation, 112
- Owls, 93, 94; hawking at night, 28, 29, 30, 97
- Oxford MS., *see* Bodleian MS.
- Pacius, Johann Erhard, German edition of the *De Arte Venandi*, lvii, lxxvi; title page, lxxvii
- Palatine library, lxx
- Palermo: Cathedral at, cvi; Norman apse of Cathedral, 334; Palace of La Zisa at, 546; Royal Palace at, 395, 490; tomb of Emperor Frederick II, 535
- Parasites, external, 428-31; internal, 431
- Parco per Uccellagione, cvii
- Parma, Frederick's defeat at, xlii
- Parrot, from India, 59; tongue of, 77
- Passage falcons: blain in, 428; capture of, 144-46; lice on, 428
- Pells, John, 452
- Perch, high, xl, 106, 161, 162, 173, 419-20; illustrations, 115, 165, 186, 429, 430; placing falcon on, 163, 164, 173, 182-83; removing falcon from, 184
- Perch, low, xl, 106, 161, 162, 419, 420; illustrations, 167, 185; placing falcon on, 163, 164, 173; *see* Block
- Peregrine falcon, xxxix, 29, 110; capture of, 144-45; choice of, 364; crane hawking with, 309; croaks in, 427; description of, 122, 510-17; dislike of ducks in, 386, 409; dislike of lure in, 366-69; hawking at the brook with, 363-414; heron hawking with, 353; illustrations, 101, 359, 360, 362; nesting of, 111; plumage of, 122-24; testing flight of, 365; training, to wait on, 369-84
- Perunctum*, *see* Oil gland
- Petau Collection, lxxiv
- Peter II, King of Sicily, 495, 498
- Peter III of Aragon, 495, 497-98
- Petrarch, xxxvi, xxxvii
- Pichon, Baron Jérôme, xxxviii, lx-lxi, lxxii, lxxxi
- Pin, *see* Croaks
- Placing half-seedled falcons on perch, 173
- Placing sighted falcons on perch, 182

- Planetarium, Frederick's, xxxviii
 Pliny, xxxix, 109
 Plumage, 79, 89, 97; age shown in, 113; hunger traces in, xl, 426; *see* Feathers
 Poems, 493-94, 496, 498, 527
 Poetry, xxxvi, 1
 Popes: Celestine IV, 493; Gregory VII, 485; Gregory IX, 488, 493; Honorarius II, 481; Honorius III, 488; Innocent III, 487, 488; Innocent IV, 493; Nicholas II, 483
 Portraits of Frederick and Manfred, xxxix, lxix, lxxi, lxxvi; on coins and medals, 471; from Exultet Rolls, 480; from Italian print, 477; notes on the, 503-4; in Vatican MS., xxxi, xxxiii, xxxiv, 534
 Prey, birds of, *see* Birds of prey
 Primary feathers, 83, 84, 89
 Prologue, General, to the *De Arte Venandi cum Avibus*, 3-4
 Purse, *see* Sack, falconer's
 Puttiala, Maharaja of, 460
- Rabartens, M. de, 452
 Raking away, 371, 388, 400, 408-9, 413-14; prevention of, 398-400; reasons for, 388-91; recovery of falcon in act of, 391-400, 413-14
 Rapacious birds, *see* Birds of prey
 Raptorials, *see* Birds of prey
 Redpath Library, 461
 Refuge, outdoor, for falcons, 114, 134
 Rennes MS. of *De Arte Venandi cum Avibus*, lvii, lxi-lxii
 Restlessness, xli, 169, 173, 190
 Ringing up, 342, 348; in hawking at the brook, 365, 380, 393, 404, 407, 413
 Robert Guiscard, Duke of Apulia and Calabria, 483, 485
 Roger I, Grand Count of Sicily, xxxvi, 484, 485
 Roger II, King of Sicily and Italy, 485-86; hunting scene in chamber of, 490; tomb of, 264
 Rossetti, Dante Gabriel, I, 493, 494, 496
- Sack, falconer's, xl, 106, 151, 281
 Saint Gorgon Statue, notes on, 473; illustrations, 154, 155
 Saker falcon, xxxix, 110, 121; capture of, 145; crane hawking with, 309; description of, 121, 516; fear of water in, 328; feeding, 160; feeding on heron-train, 319, 320; flown at small birds, 317; heron hawking with, *see* Heron hawking; illustration, 316; modes of flight in heron hawking, 327-28; nesting habits of, 111; plumage of, 121
 Salah-ad-Din, Sultan, xxxviii
 Salerno, School of Medicine at, xxxvii
 Salvin and Brodrick, on avian diseases, 427
 San Lorenzo hunting park, xcv
 Sardus, falconer for Frederick, xlii
 Sarton, George, xlii, 1
 Schlegel and Wulverhorst, 433, 439, 451
 Schlüter, Walter, 451, 460
 Schneider, Johann Gottlieb, Latin edition of *De Arte Venandi cum Avibus*, xlvi, lvii, lxxvi-lxxx
 Schöpffer (father and son), German edition of *De Arte Venandi cum Avibus*, lvii, lxxx
 Scotus (or Scott), Michael, xxxvii, xxxix, xlvi
 Screen (or curtain), xl; illustration, 429, 430
 Sea eagles, *see* Fish eagles
 Secondary feathers, 83, 84, 89
 Sealing the eyes of falcons, lx, lxi, 137-38, 146, 157, 158
 Self-defense, MS. page discussing, 88
 Semenovski Pleasure Yard, 460
 Shearer, Cresswell, xxxvi, xxxix, xcvcv, 503
 Shirkers, *see* Cowards and
 Shoulders, 63-64; illustration, 67
 Sides of birds, 72
 Simon d'Orléans, lxx, lxxii
 Skull, 76
 Slaughter, Gertrude, I, lxix-lxx
 Snow, Homer, 461
 Sock, falcon, xl, 106, 146; illustration, 165
 Sparrow hawks, xxxix, 29, 60, 92, 110; apoplexy in, 427; description of, 127, 520-25; illustrations, 211, 514; plumage of, 127
 Spinal column, *see* Vertebrae
 Spinal marrow, 77
 Spraying (or sprinkling), xli, 170, 190-91; drawing showing, 421
 Starvation, 160
 Sternum, *see* Breast
 Stomach, 79
 Stool, *see* Block
 Stooping at quarry, 401-2
 Structure and habits of birds, 3-99; variations in, 56-57
- Stuttgart MS. of the *De Arte Venandi cum Avibus*, lvii, lxxiv-lxxv; Incipit, lxxv
 Swaen, Dr. A. E. H., 451; *see also* Adelarde of Bath in Bibliography
 Swann, Kirke, 526, 527
 Swing feather (saxellus), 83, 84
 Swivel for falcon's harness, lx, 137, 140
 Swollen feet, *see* Cysts, indurated
 Syracuse, xcv
- Tail, 70, 83, 89
 Taming of half-seeded falcon, 172-73
 Taming of seeded falcon: by carrying, 158-59; without hood, 158; through sense of hearing, 170, 171; through sense of taste, 152, 170-71; by stroking, 159-70, 171; systems of, 158
 Taming of sighted falcon, 174-219; by carrying, 174-75, 181-82; on horseback with hood, 189; on horseback without hood, 193-205; by increase of light, 181; by means of the tiring, 174, 182; outdoors on foot, 189; by reducing diet, 184
 Tancred, Count of Lecce, 482, 487; church founded by, 547
 Tancred d'Hauteville, xxxvi, 483
 Taste, sense of, used in taming, 152, 170-71
 Teircels, 160
 Tertiary feathers, 83, 84, 89; *see* Feathers
 Testes and ovaries, 79
 Tetanus, 427
 Theodore, xlix
 Thomas of Capua, lxi
 Thorax, *see* Breast
 Thrush, *see* Frounce
 Thuani, Jac. Aug. (Jacques Auguste de Thou), xl, lxxv
 Tick, flying, *see* Parasites, external
 Tiring (or emergency ration), xl, xli, 106, 151, 174, 179, 180-81, 182, 184, 189, 194, 202, 203; comparison of its use with that of hood, 217
 Tongue, 77
 Toes, 74-75
 Toxic diseases, 431; *see* Diseases
 Trachea, 78
 Train, *see* Crane-train, Hare-train, Heron-train
 Training, of gerfalcon, 250-67; assistants used in, 258, 259, 260,

- 265; captive flying crane used in, 262-66; crane-train used in, on foot and on horseback, 257-61; dogs used in, 252; flights at small birds in, 256; hare-train used in, 252-55; walking crane used in, 262; wild hare used in, 253
- Trani, xcv; Castle of, 396; Cathedral of, 333
- Travel with falcon: half-seeled, 201; hooded, 216-17; unhooded, seeled, 195-205; in various localities, 201-2; in various seasons and weather, 195-201
- True noble falcons, 110; capture of, 145, 146; description of, 124; nesting of, 111; plumage of, 127
- Tuberculosis, 427
- Ullman, B. L., lxxxii
- University of Naples, xxxvi, xcvi
- Unseeling of falcon, partial, 171-72; total, 173-74
- Valencia MS. of the *De Arte Venandi cum Avibus*, lvii, lxi; incipit of, lv; passage missing from, 379-80
- Valkenswaard, 439, 452; illustration, 454; map, 453
- Vatican Codex Pal. Lat. 1071, lvii, lxii, lxxi, lxxvi; colored marginal illustrations of, xxxviii, lxii, lxix-lxx, lxxi, lxxiv, lxxvi, lxxxi, lxxxii, lxxxiv, lxxxv, lxxxvi, lxxxvii, cv; illustrations from, xxxi, xxxiii, lvi, (in color) facing 3, 12, 35, 36, 65, 66, 67, 68, 86, 87, 131, 132, 156, 185, 186, 187, 422, 423, 437
- Velser, Marcus, edition of *De Arte Venandi cum Avibus*, xlvi, lvii, lxx, lxxv, lxxvi, lxxxi; title page, lxvi
- Vertebrae, 76
- Vienna MS., lvii, lxx, lxxi; Incipit, lxviii
- Vigna, Piero della, 493
- Vultures, 9, 58; feeding habits of, 20; sense of smell in, 22
- Waiting on, 106; best environment for, 370; best hours for, 370; best weather for, 371; falcon's modes of flight in, 372-73; in hawking at the brook, 265; reasons for falcon raking away when, 381-84; recalling a falcon, 373-74; slipping a falcon, 371; training a peregrine falcon in, 369-84
- Waller, Renz, 459
- Walter Anglicus, Master, Frederick's falconer, xlii
- Walter of the Mill, 487
- Washburn, Gordon, 473
- Washed meat, 157, 407
- Water fowl, 7, 8, 15, 18, 49, 51, 63, 73, 94, 96; care and feeding of young, 54; feeding habits of, 15, 16, 17, 61; moult of, 99; refuges of, 18, 97; sleeping habits of, 18
- Werth, xxxviii
- Wetmore, Alexander, 526, 527
- William, Frederick's falconer, xlii
- William, King Roger's falconer, xlvi
- William I, the Bad, 486; genealogy, 484
- William II, the Good, 482, 487; genealogy, 484
- Wind: cranes feeding in, 274, 283; crane hawking in, 283-87; heron hawking in, 329, 343-45, 346, 349; luring falcon in, 239; mounting horse in, 194; training sakers in, 324; traveling with falcon in, 196
- Wings: movement of, 69-70; structure of, 64-69; used in lure, 225-27, 317, 363
- Winkelmann, E., 503, 504
- Wulverhorst, *see* Schlegel and
- Yatrib, Book of, xlix
- Yolanda (or Isabelle) of Brienne, lxxii
- Zodiac, signs of, 321-23

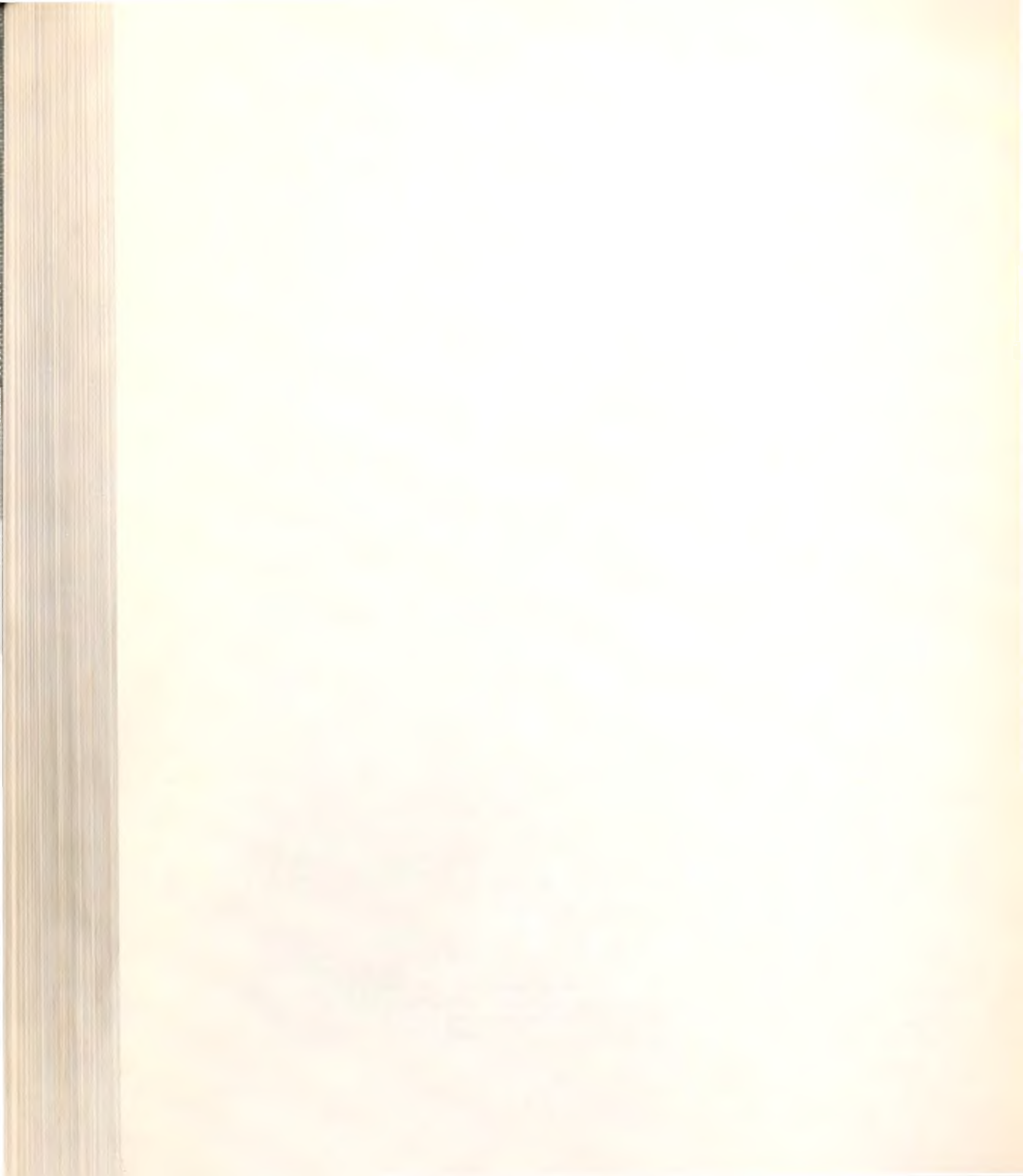

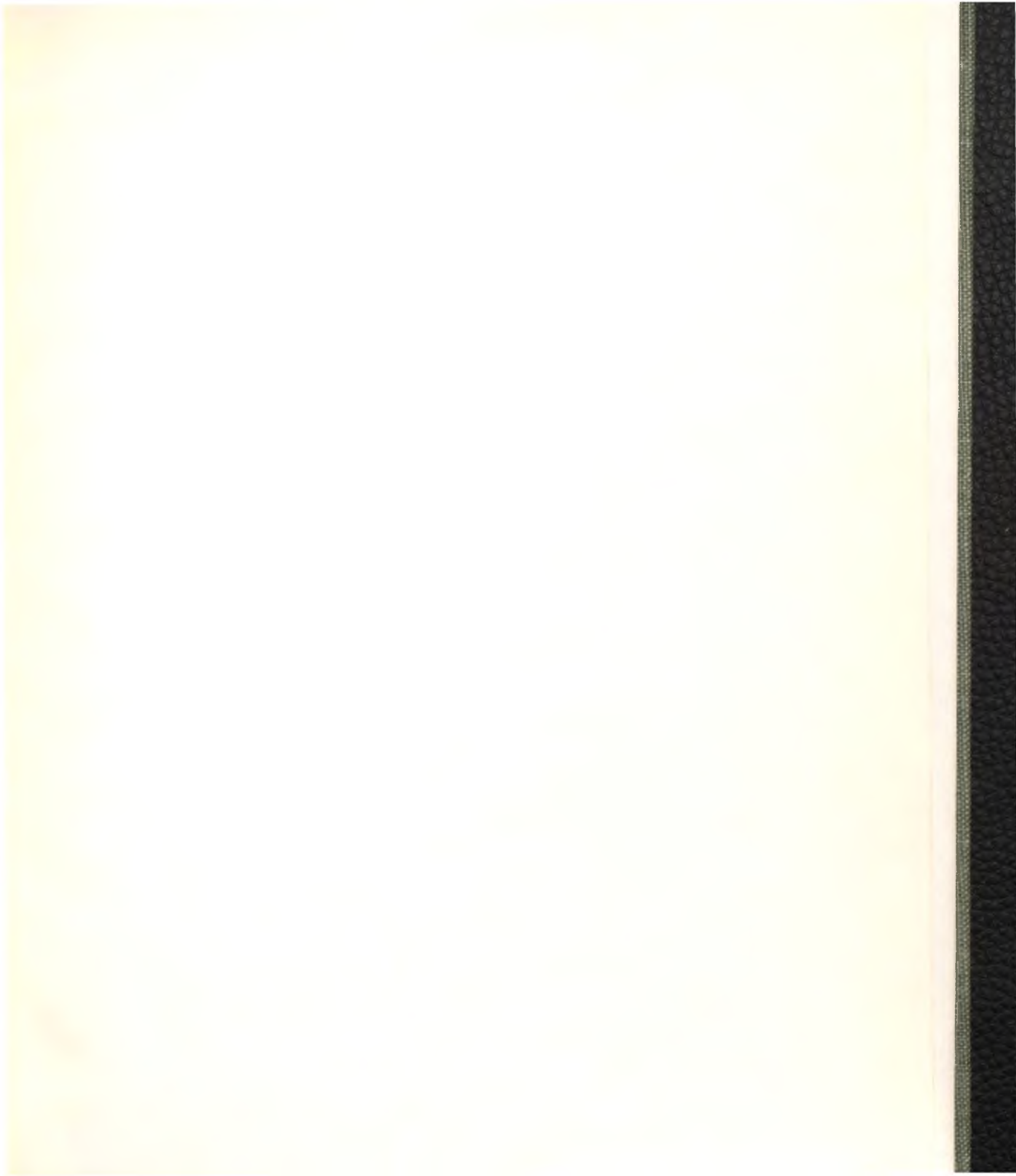



MCGILL UNIVERSITY LIBRARY

ORHV

|| F87.E.2

440036



